

UNITED REPUBLIC OF TANZANIA
Prime Ministers Office for Regional
Administration and Local Government



The Dar es Salaam City Council



CONSULTANCY SERVICES FOR THE
CONCEPTUAL DESIGN OF A LONG TERM
INTEGRATED DAR ES SALAAM BRT
SYSTEM AND DETAILED DESIGN FOR
THE INITIAL CORRIDOR

Environmental and Social Impact Assessment (ESIA)

Dar es Salaam
February, 2007
Rev 00

LOGIT

i **inter-consult ltd.**

JGP

Integrated Dar Es Salaam BRT System Phase I

Environmental and Social Impact Assessment (ESIA) Study

I N D E X

1.0 Introduction

- 1.1 Project Location
- 1.2 Responsibility for ESIA study and Project Engineering Development
- 1.3 Project Objectives
- 1.4 Precedents
- 1.5 ESIA Consultation and Disclosure

2.0 Project Summary

2.1 Project Infrastructure and Physical Works Description

- 2.1.1 Cross Sections
- 2.1.2 Bus Stations, Feeder Stations and Terminals
- 2.1.3 Bus Depots and Maintenance Shops
- 2.1.4 Intersections
- 2.1.5 Pedestrian Crossings
- 2.1.6 Bridges and other Special Structures
- 2.1.7 Corridor Pavement

2.2 Project Construction Planning

- 2.2.1 Construction Schedule
- 2.2.2 Construction Labor Requirements
- 2.2.3 Construction Materials Sourcing
- 2.2.4 Construction Support Infrastructure

2.3 Project Investment Cost

2.4 Project Operational Characteristics

- 2.4.1 Standard Vehicle and Fleet Dimensioning
- 2.4.2 Trunk and Feeder Service Design
- 2.4.3 Operational Control Systems
- 2.4.4 Project Staffing

2.5 Public Transportation Reorganization

2.6 Central Business District Traffic Reorganization

2.7 Project Business Plan

3.0 Alternatives Analysis

3.1 Technological Alternatives

3.2 Alignment Alternatives

4.0 Baseline Conditions

4.1 Methodological Framework

4.2 Indirect Area of Influence (IAA) Baseline Conditions

4.2.1 Physical Environment

4.2.1.1 Climate

4.2.1.2 Geology and Geomorphology

4.2.1.3 Hydrogeology

4.2.1.4 River Systems and Hydrology

4.2.1.5 Air Quality

4.2.2 Biological Environment

4.2.2.1 Current Vegetation Cover

4.2.2.2 Fauna

4.2.3 Socio-Economic Environment

4.2.3.1 Population

4.2.3.2 Historic Urban Growth Patterns

4.2.3.3 Urban Structure

4.2.3.4 Transportation Infrastructure

4.2.3.5 Other Physical Infrastructure / Utilities

4.2.3.6 Social Infrastructure

4.3 Direct Area of Influence (DAI) Baseline Conditions

4.3.1 Physical Environment

4.3.1.1 Geology and Soils

4.3.1.2 Flood Plains and Natural Drainage Pattern

4.3.1.3 Water Quality

4.3.1.4 Noise Pollution Profile

4.3.2 Biological Environment

4.3.2.1 Flood Plain Vegetation and Fauna

- 4.3.2.2 Urban Vegetation and Landscaping
- 4.3.3 Socio-Economic Environment
 - 4.3.3.1 Socio-Demographic Characteristics
 - 4.3.3.2 Local Urban Structure
 - 4.3.3.3 Land Use
 - 4.3.3.4 Utilities
 - 4.3.3.5 Historical, Cultural and Archeological Features
 - 4.3.3.6 Social Organizations

4.4 Directly Affected Area (DAA) Baseline Conditions

- 4.4.1 Land Use
- 4.4.2 Project Affected People
- 4.4.3 Current Corridor Traffic
- 4.4.4 Corridor Utilities Survey
- 4.4.5 Corridor Vegetation

5.0 Legal and Institutional Framework

5.1 Institutional

- 5.1.1 Environmental Planning and Permitting
- 5.1.2 Urban Planning
- 5.1.3 Transportation Planning and Infrastructure Implementation and Operation
- 5.1.4 Expropriation and Resettlement

5.2 Legal

- 5.2.1 Environmental Planning and Permitting
- 5.2.2 Urban Planning and Zoning
- 5.2.3 Transportation Planning and Infrastructure Implementation and Operation
- 5.2.4 Expropriation and Resettlement

6.0 Environmental and Social Impact Assessment

- 6.1 Methodological Framework
- 6.2 Activities with Impact Potential
- 6.3 Impact Receptors
- 6.4 Impact Identification and Description
- 6.5 Environmental and Social Mitigation and Management

7.0 Conclusions

8.0 List of References

ANNEXES

Annex 1 – List of Consulted PAP's

Annex 2 – Intersections

Annex 3 – Materials Sourcing Technical Data Sheets

Annex 4 – Articulated Bus and Feeder Bus Illustrations

Annex 5 – Current and Proposed Routes for IAI Daladala Services to be Re-routed

Annex 6 – Vegetation Photographic Report

Annex 7 – DAI – Land Use Identification

Annex 8 – DAA – Land use Identification

Annex 9 – Land Use Photographic Report

Annex 10 – Traffic Management During Construction

1.0 Introduction

1.1 Project Location

This Environmental and Social Impact Assessment (ESIA) study concerns Phase I – Parts A and B of Dar Es Salaam’s Bus Rapid Transit system (DART).

Dar Es Salaam is the capital of the United Republic of Tanzania and covers an area of 1,800 km² in the municipalities of Kinondoni, Ilala and Temeke.

The proposed system is a closed trunk – feeder system, we will refer to as trunk corridor. Phase I will have 20.9 km, 29 bus stations, 6 feeder stations, 5 terminals and 2 bus depots.

The trunk corridor in its Phase I starts at the Kivukoni Terminal, near the Kigamboni Ferry Terminal, along the Kivukoni Front and Morogoro Road, ending in a Terminal at Kimara Mwisho. The Ubungo Terminal is located at an intermediate point along this stretch, near the intersection with Nelson Mandela / Sam Nujoma Road.

A branch running along Kawawa Road from Magomeni up to Morocco, and another branch along Msimbazi Street to Kariakoo, are also part of Phase I. The Kawawa Road branch will have a terminal at the end of Morocco (Junction with Ali Hassan Mwinyi Road) while the Msimbazi Street branch will have a terminal at Kariakoo near the TRC railway line opposite the current Scandinavian Bus Terminal.

Part A of Phase I of the trunk corridor covers 10 Km. embracing the stretch from the Kivukoni Terminal to Ubungo Terminal. Part B of Phase I covers the remaining 11 Km until Kimara Mwisho, as well as the Kawawa Road and Msimbazi Street branches.

Integration along the corridor will take place at terminals or at stations through connecting services called ‘feeder routes’, which assure interaction of the trunk – system with other areas of the city surrounding the main corridor area of influence. Feeder services will be offered at Kimara, Morocco and Ubungo terminals, and Shekilango, Urafiki Mahakama, Magomeni Mapipa and Fire stations along Morogoro Road, and Mwinyijuma and Kinondoni along Kawawa Road.

Figure 1.1.a illustrates the location of the project within Dar Es Salaam, distinguishing Part A from Part B segments of Phase I.

Figure 1.1.a
Project Location – Phases 1A and 1B

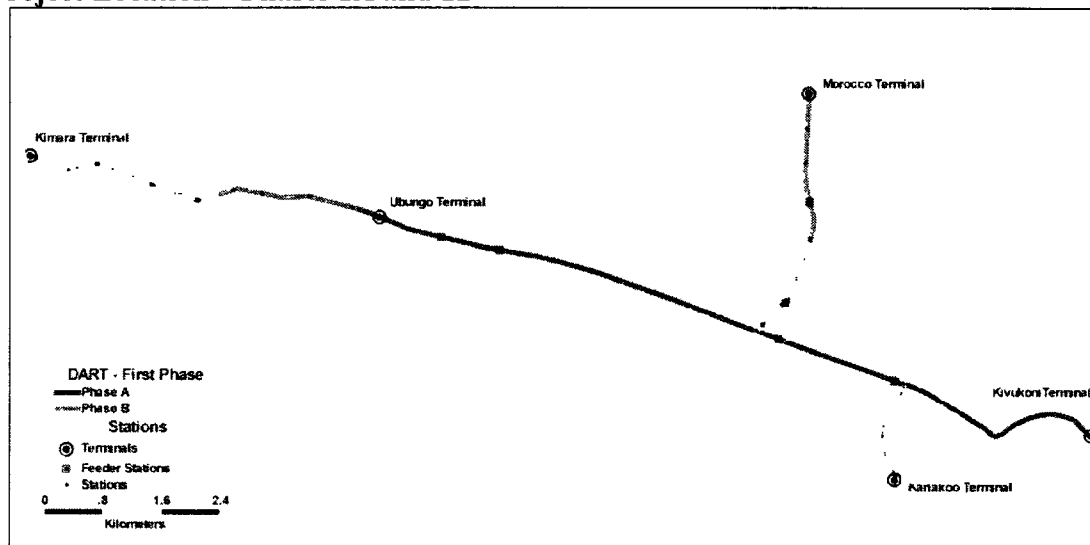

1.2 Responsibility for ESIA study and Project Engineering Development

Project Sponsor:

Dar Es Salaam City Council

Project Engineer:

LOGIT: Logit Engenharia Consultiva Ltda, www.logitconsultoria.com.br, São Paulo, Brazil

INTERCONSULT: Inter-consult Limited, www.interconsult-tz.com, Dar es Salaam, Tanzania

Environmental & Social Consultants responsible for this assessment:

LOGIT: Logit Engenharia Consultiva Ltda, www.logitconsultoria.com.br, São Paulo, Brazil

INTERCONSULT: Inter-consult Limited, www.interconsult-tz.com, Dar es Salaam, Tanzania

JGP Consultoria e Participações Ltda, São Paulo, Brazil

1.3 Project Objectives

One of the major challenges facing large cities in developing countries is trying to cope with service provision for rapidly expanding urban populations amidst dwindling resources. Swelling population creates problems of urban sprawl into unplanned areas of cities where there is little or no road infrastructure and public services. With economic development car ownership grows, making it impossible to provide roads and parking space for so many cars.

Municipal governments in these major urban centers are required to mobilize significant resources for infrastructure and services for efficient movement of people and goods. Large populations demand transport services, which can only be provided by well organized and managed public infrastructure and service. Despite these facts public transportation has been relegated in government priorities.

The upshot is that urban transport has become a very sensible social problem in many cities because governments have left the market run out of control, allowing too many operators without adequate regulation. Low fares and lack of organization have created serious antagonism between the interests of the user and the operator.

In Dar Es Salaam lack of infrastructure and regulation have resulted in unreliable service with astonishingly low levels of quality. Meanwhile, the minimal investment engaged by operators, explain the proliferation of small vehicles (Daladalas).

A greater number of small buses are necessary to transport the same amount of passengers. Allied to small fares, the obvious consequences are overcrowded vehicles and congested roadways.

To make business profitable, vehicles need to run full almost all the time. This means there are no schedules at all, long waiting times in the middle of the route, absence of services during some hours in some regions, especially at late hours in the evening. Another aspect of the problem are the bottlenecks generated in some stops due to the concentration of vehicles. In places like Posta or Bibi Titi Road, it is common to see huge congestions, before the Daladala stops and an empty street after this point.

The serious public transport problem facing Dar Es Salaam has two main causes. The small obsolete passenger vehicles operating without control, and the lack of safe road infrastructures that endanger both motorized and non-motorized transport users, including pedestrians.

The rationale behind the proposed Dar Es Salaam Bus Rapid Transit System (DART) is to regulate urban transport through a specialized infrastructure known as Bus Rapid Transit (BRT) that has been tested in other cities over the last 25 years.

BRT is a bus-based mass transit system that essentially follows the performance and characteristics of a modern rail-based transit system but at a fraction of the cost. It consists of a corridor of exclusive and segregated lanes, high capacity articulated buses and high performance boarding with central platform for level boarding and large closed stations that allow fare payment outside the trunk vehicles. The proposed system can reach average speeds of 25 km/h.

The overall objective is to introduce affordable mobility, improve quality of urban environment and in particular the quality of life of low income urban population which most depends on public transport.

The specific objectives of Dar Es Salaam BRT system are:

- To **increase the level of mobility** of the majority of residents enhancing their participation in a wide range of economic and social activities,
- To **facilitate the use of Non Motorized Transport (NMT)** by improving service roads and implementing parallel bicycle routes allowing for integration of bicycles and the bus system and for reduction of congestion in the carriage way,
- To **meet the continuous increase of travel demand** of the city, and
- To **have a comfortable public transport system** at reasonable cost to the users and yet profitable to the operators, using quality high capacity buses which meet international service standards, environmentally friendly, operating on exclusive lanes at less travelling time.

The DART project will also improve the quality of public transport by providing:

- Closed, clean and spacious stations and terminals.
- Modern and efficient bus depots.
- Modern vehicles, preferably based on low emission engines according to international standards.

Additionally, the new urban landscape will considerably improve with the application of new concepts of use of urban space, since it will promote changes predominantly in the Direct Area of Influence. Businesses can be reorganized and gain scale with the new service. Stations and terminals, and the new landscape design, will bring safety and comfort not only for those who use the system, but for all local population, once it allows free sidewalk and a better organized public space.

1.4 Precedents

The DART project was initiated when UNEP became interested in developing a pilot BRT project in Africa in cooperation with the Institute for Transportation and Development Policy (ITDP). ITDP contacted the Association for the Advancement of Low-Cost Mobility, an NGO in Dar Es Salaam that subsequently presented the idea to Major Kleist Sykes. Positive response led ITDP to securing a project preparation grant from the GEF through UNEP.

Dar Es Salaam's City Council was already familiar with the importance of Non-Motorized Transport, and had implemented some successful pilot projects under the World Bank Sub-Saharan African Transport program (SSATP) from 1995 to 2000. The Vice-President's Office, on 9th July 2002, stated that after consultation with the President's Office – Regional Administration and Local Government (a national ministry), they would support the implementation of the BRT project because it conforms to national development objectives as articulated in the National Transport Policy (NTP). Implementation of the NTP in Dar Es Salaam City is the responsibility of the Dar es Salaam City Council and its three Municipalities.

The City Council established three development priorities – one of which was implementing Bus Rapid Transit. In an official City Council Session on the 14th of May 2003, the Lord Mayor, City Director and members of the City Council stated their commitment to implementing the BRT project. On 4th July 2003, the Minister of Communications and Transport presented the BRT project to the National Parliament, which endorsed the project.

The National Government and the City Council, with ITDP, then approached UNEP / GEF to support a medium sized grant for the project. The City Council approved an allocation to begin planning the system. In April, 2004, World Bank support was secured for the detailed engineering of the first BRT corridor from the Central Corridor Transport Project of the World Bank (Credit #CR8888-TA). In June 2004, US AID, through ITDP, agreed to provide complementary funds to assist the Dar Es Salaam City Council with BRT project-related capacity building.

On the 16th of June 2004 the project was formally launched. A Project Management Unit (PMU) was established in City Hall. A steering committee for the BRT Project was formed by the Major of the City (chair person), the Dar Es Salaam City Director, the Majors of Dar Es Salaam Municipalities (Ilala, Kinondoni and Temeke), the Municipal Directors, the Director of Surface Transport (Ministry of Communications and Transport), the Managing Director of TANROADS, the Manager of the Road Fund Board, the Director of Environment (Vice Presidents Office), the Dar Es Salaam Region Administrative Secretary, the Commissioner of Budget (Ministry of Finance), the Director of Local Government

(Presidents Office, Regional Administration and Local Government), and the Executive Secretary of the Association for Advancing Low Cost Mobility (NGO).

In 2005, a contract was awarded for overall conceptual planning and detailed planning for the first 10.0 Km. of the DART system. Subsequently, the contract was extended to include detailed design and engineering for a longer project totalling 20.9 Km. which was deemed to be the necessary minimum extension to make Phase I of the system viable.

At the date of submission of this Environmental and Social Impact Assessment, planning and engineering on the first 10.5 Km. (Phase I – Part A) has been completed, and studies on the extension (Phase I – Part B) are being finalized. In May 2006, an Environmental Impact Assessment, a Social Impact Assessment and a Resettlement Action Plan relative to Phase I – Part A were submitted to the World Bank. However, since the project was extended, it was decided to prepare new assessments and resettlement plans covering all of Phase I (20.9 Km.).

Additional work concluded on the project includes studies on institutional restructuring, project business plan and financial model, downtown parking and traffic circulation plan, capacity building program for municipal officials and design of facilities for integration of DART with non-motorized transport. A traffic model for Dar Es Salaam in order o support traffic and demand analysis has also been developed.

1.5 ESIA Consultation and Disclosure

Extensive consultation was conducted during ESIA preparation. This included a wide variety of stakeholders, including public entities with direct or indirect involvement with the project, as well as residents and businesses located along the corridor, including those that will be directly affected by expropriation.

The main public entities / public officers consulted during ESIA preparation include:

- Vice President's Office (VPO)
- Prime Minister' Office (PMO)
- National Environment Management Council (NEMC)
- Tanzania Electricity Supply Company (TANESCO)
- Dar Es Salaam Water Supply and Sanitation Company (DAWASCO)
- Tanzania Telephone Communication Limited (TTCL)
- Tanzania Railways Corporation (TRC)
- Dar Es Salaam City Council (DCC)
- The Municipalities of Temeke, Kinondoni and Ilala
- Ward Executive Officers along the alignment

Further to public entity consultation, several local experts and university professors specialized on transportation planning, urban planning, environmental management and other pertinent skills were contacted and contributed with their views toward adjustment of the DART project to better meet local needs.

Similarly, a representative sample of project affected peoples (PAP) were interviewed in order to obtain an idea of expectations on the project and other information useful for planning of future project disclosure. The list of consulted PAP is included in **Annex 1**.

Furthermore, it is worth noting that during ESIA preparation, a Property Survey and a Socio-Economic Survey of all residents and businesses in directly affected properties was conducted through application of detailed questionnaires. Detailed description of this procedure is included in the project's Resettlement Policy Framework. Statistical analysis of the results of the surveys will be a part of the specific Resettlement Action Plans (RAP) for DART Phase I – Parts A and B.

This ESIA will be submitted to public consultation and disclosure as part of its approval procedure. This will involve posting the complete document in an appropriate institutional website as well as preparation and distribution of a summary prospect in simple to understand language that will be distributed among all key stakeholders and affected residents and businesses. Both the website and the printed prospect will provide contact instructions for comments / criticism on the project.

A public presentation of the project's expected benefits and impacts and respective mitigation strategies will be held at an easily accessible location to be broadly disclosed in advance. This will take place within 60 days after posting of the ESIA in the Internet and will be recorded.

Minutes of the public meeting will be prepared, as well as a list of comments / criticisms organized according to type of stakeholder.

2.0

Project Summary

2.1

Project Infrastructure and Physical Works Description

This section describes all physical infrastructure to be implemented during Phase I – Parts A and B. Level of detail has been taken to equivalent engineering stages for all installations. However, it is worth noting that some project modifications are still being analyzed at the time of preparation of this ESIA study. Hence, some minor layout alterations may still occur, particularly in the case of Part B.

2.1.1 Cross Sections

Standard cross sections have been established for the DART project for two situations: cross section along the corridor, and standard cross section at bus stations. Basic design guidelines adopted in each case are the following:

Standard cross section along the corridor:

- Road shall have dual carriage way of four lanes (2x2) for mixed traffic and two lanes (1x1) for BRT vehicles.
- The minimum width of mixed traffic lanes will be 3.0 m and minimum width of BRT vehicle lanes will be 3.3 m.
- Sidewalk and bicycle lanes shall be provided in both directions whenever possible, with 2.5 m minimum width for sidewalks and 1.5 m wide bicycle lanes.

Standard cross section at bus stations will include additionally:

- 5.0 m wide station at the centre of the cross section.
- Two (1x1) additional lanes for BRT overtaking vehicles.
- 0.3 m wide median between bus lanes and private cars.

The standard cross sections are illustrated in **Figures 2.1.1.a** and **2.1.1.b**. As may be noted, these standard sections result in total width of 38.5 m along the corridor and 49,0 m at bus stations. However, this space is not always available and several design compromises have been adopted along the corridor's alignment. Thus, the standard sections in **Figures 2.1.1.a** and **2.1.1.b** should be understood as "ideal sections" which can be modified according to the adjusted cross sections described below:

Figure 2.1.1.a
Standard Cross Section at Stations

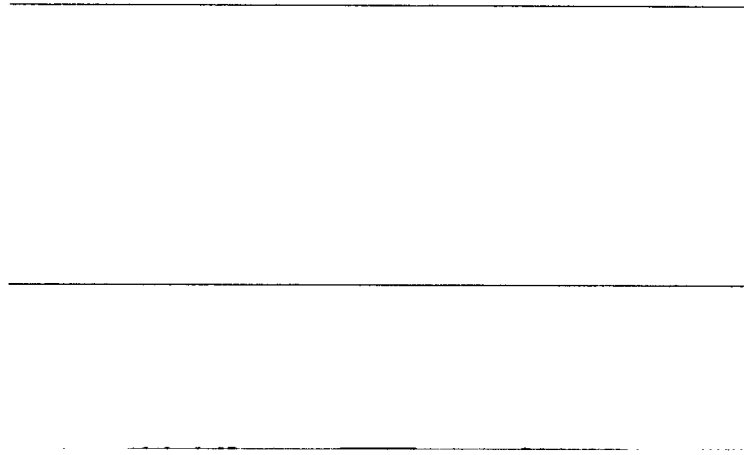
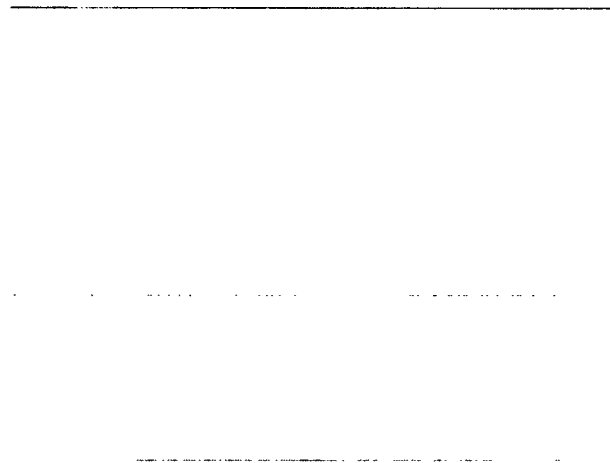

Figure 2.1.1.b
Standard Cross Section off Station



Stretch 1 -Kivukoni Front - from Kivukoni Terminal / Kigamboni Ferry to City Council Station

This section has two 3.5 m wide BRT lanes, one per direction, a 3.0 m. wide mixed traffic lane in the southeast bound direction only, plus a 3.0 m wide bikeway lane on the ocean side on the same roadway level, separated from the vehicle lanes by concrete separators. A 3.0 m pedestrian's boulevard will be provided on the ocean side; a retaining wall will be necessary where there is a slope of more than 2 m, and where fills are executed along the coastline. (See **Figures 2.1.1.c** and **2.1.1.d** for cross sections at station and off station locations along this segment).

The City Council Station will be situated in a large area presently used as a parking lot and partly occupied by temporary administrative structures that will need to be removed. The project proposes the transformation of the area next to the future station into a public open space.

Figure 2.1.1.c
Stretch 1 Cross Section at Station

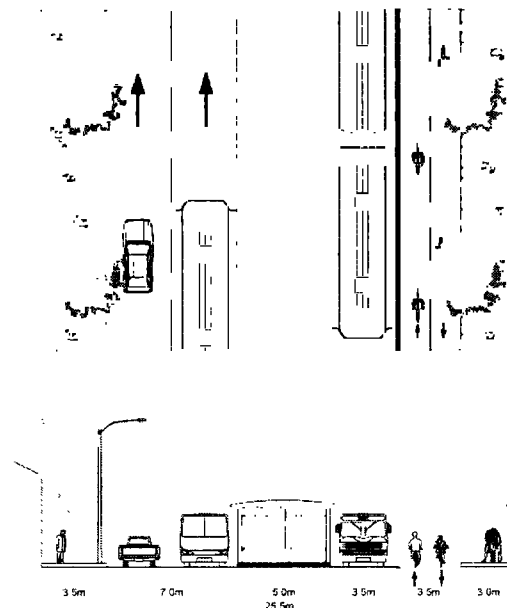

Figure 2.1.1.d
Stretch 1 Cross Section off Station



Stretch 2 - Morogoro from City Council Station to Bibititi Road

The existing Morogoro road section is narrow, it is 6.8 to 9 meters wide and the right of way is about 11 m. This section will be reserved to buses and non-motorised traffic (cyclists and pedestrians). Raised bus way of about +100 mm will be provided for the entire section. The entire street will be on the same level as the raised bus way. There will be no kerbs, and bollards will be provided to separate the bus way from walkways.

The bus way will be 7 m wide, which will leave about 2 m each side for walkways. Consequently, where the right-of-way is wider, walkways will be wider. The bollards shall be placed at 1.5 m intervals. Cyclists will be permitted to use the bus way, and could easily move onto the walkway when buses need to overtake. The raised portion will extend across junctions giving priority to the bus way and providing an elevated intersection to slow traffic on cross streets.

The Station located close to the junction of Morogoro and Libya will have no lanes for overtaking, it will have a berth 4 m wide, 3.3 m BRT lanes, and sidewalks 1.5 m wide for a short length to make them fit in the available space (see **Figures 2.1.1.e** and **2.1.1.f**).

Figure 2.1.1.e
Stretch 2 Cross Section at Station

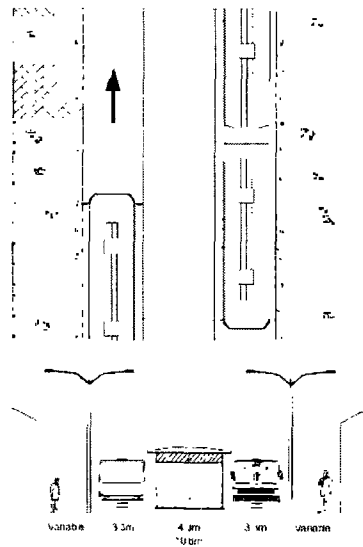
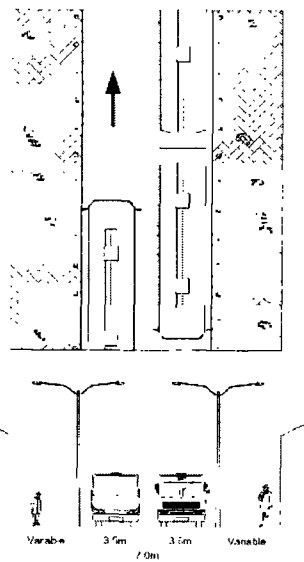

Figure 2.1.1.f
Stretch 2 Cross Section off Station



Stretch 3 - Morogoro from Bibititi to United Nations

The right-of-way in this stretch is constrained. Therefore, a narrower cross section is planned so that it can fit into the right of way without having major impact on the roadside properties. It will have the following elements as illustrated in **Figures 2.1.1.g** and **2.1.1.h**:

- 1.5 m. wide bikeway on roadway level on both sides;
- 4 m. sidewalks on both sides;
- 6.5 m. lanes per direction for mixed traffic;
- 3.3 m. lanes per direction for BRT vehicles at stations;
- 3.3 m. lanes per direction for BRT vehicles between stations
- 1.5 m. wide median strip between bus lanes off stations, 0.3 m wide median strip between bus lane and private cars at stations.

Impacts on existing roadside still concern:

- Fences and walls south of the intersection of Morogoro and Ally Khan Road.
- Fence and one of the Judicial Court's buildings;
- Fences, parking and guard house of the Tanzanian Technology Institute;
- Part of the parking area of the Vijana building;
- Gas station fences.
- Fire department fences and part of its garden;
- Trees and utility poles.

Figure 2.1.1.g
Stretch 3 – Cross Section at Station



Figure 2.1.1.h
Stretch 3 – Cross Section off Station

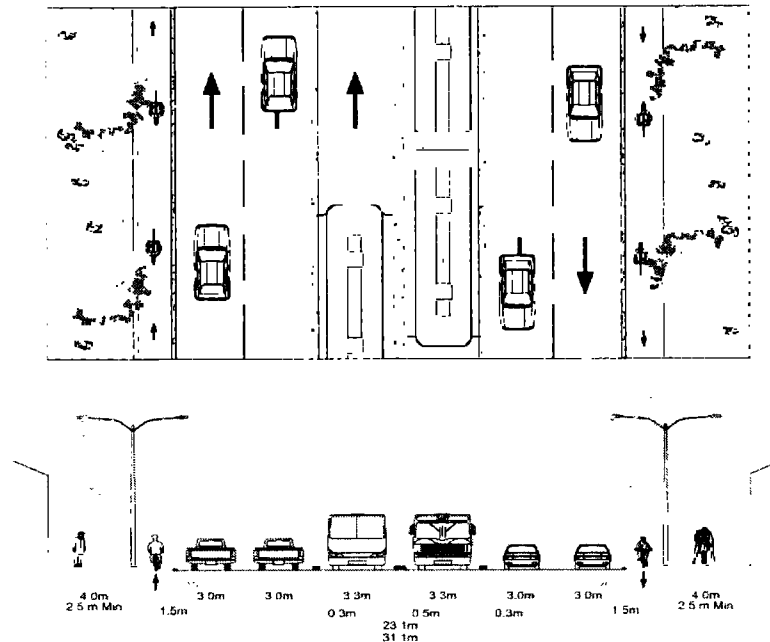

Stretch 4 - Morogoro from United Nations to Kawawa

There are two box culverts and one bridge along this segment, and they will be widened. Also, there will be a significant quantity of earth work (fill and cut) in this segment. The proposed cross section at stations is 49.0 m wide and in between stations it is 38.5 m. wide. The available roadway section, including sidewalks, is approximately 24 m. This means that the roadway will have to be widened 14.5 m. between stations and 25 m. at the stations. This will require major earthwork (mostly filling).

The proposed cross section, as illustrated in **Figures 2.1.1.i** and **2.1.1.j**, consists of the following items:

- 4.0 m. sidewalks on both sides
- 2.5 m. wide bikeway on both sides of the road
- 1.5 m wide planting strip between bikeway and mixed traffic lanes
- 6.5 m. lanes per direction for mixed traffic on both sides
- 7.0 m. lanes per direction for BRT vehicles at stations
- 3.5 m. lane per direction for BRT vehicles between stations

- 1.0 m wide median between BRT lanes off stations
- 0.8 m wide median strip separating the BRT vehicles and private cars
- 0.5 m wide median strip between bus lane and private cars at stations.

Location of Jangwani Station is planned to avoid the bridge. The wide cross section will require major earth work.

The sidewalk next to Magomeni Mapipa Station on northwest approach has been narrowed to 2.5 m to leave enough space for construction of frontage road. A station for feeders coming from Kigogo will be provided on this frontage road, this will require demolition of existing buildings.

Figure 2.1.1.i
Stretch 4 – Cross Section at Station



Figure 2.1.1.j
Stretch 4 – Cross Section off Station

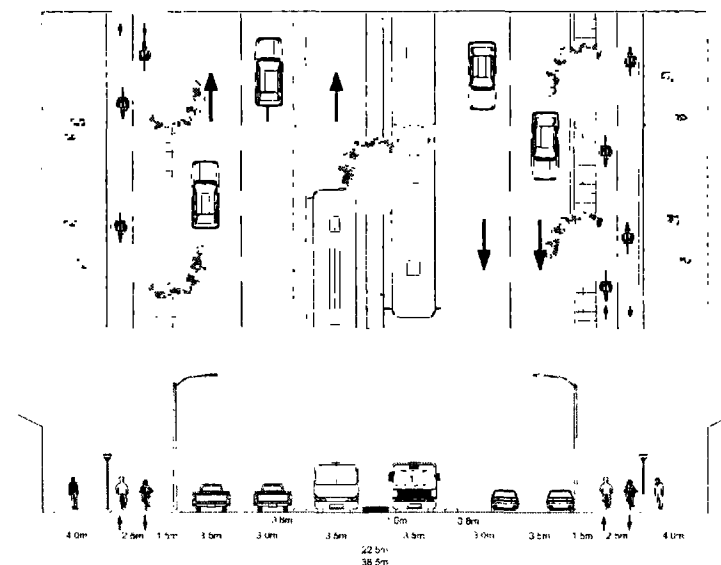

Stretch 5 - Morogoro from Kawawa to Ubungo

The designed cross section is 38.5 m wide between stations and 49.0 meters at stations, including pedestrian facilities and bikeway on both sides (see **Figures 2.1.1.k** and **2.1.1.l**). The proposed cross section will consist of the following items:

- 4.0 m. sidewalks on both sides
- 2.5 m. wide bikeway on both sides of the road
- 1.5m wide planting strip between bikeway and mixed traffic lanes
- 6.5 m. lanes per direction for mixed traffic on both sides
- 7.0 m. lanes per direction for BRT vehicles at stations
- 3.5 m. lane per direction for BRT vehicles between stations
- 1.0 m wide median between BRT lanes off stations
- 0.8 m wide median strip separating the BRT vehicles and private cars
- 0.5 m wide median strip between bus lane and private cars at stations

A drainage channel runs alongside the roadway where the corridor is planned. This drainage channel will be filled and a subsurface drainage system with catch pits on the road will be provided.

A number of buildings will have to be removed to allow for construction of U-turns and Bus Stations.

Figure 2.1.1.k
Stretch 5 – Cross Section at Station

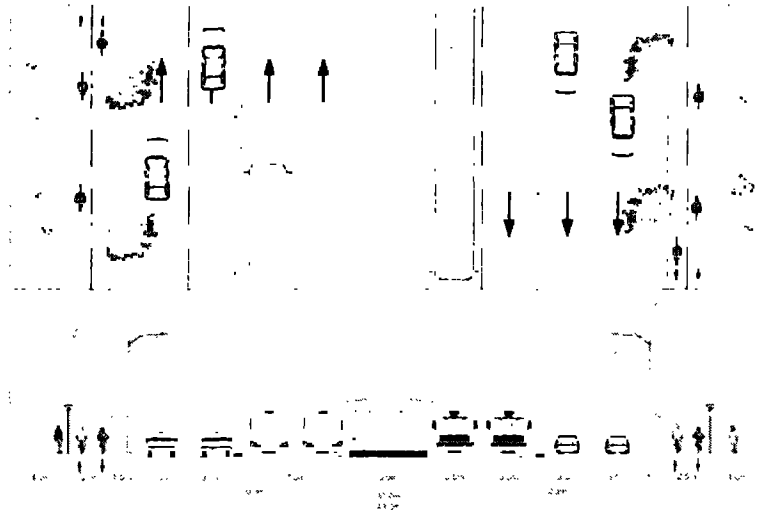
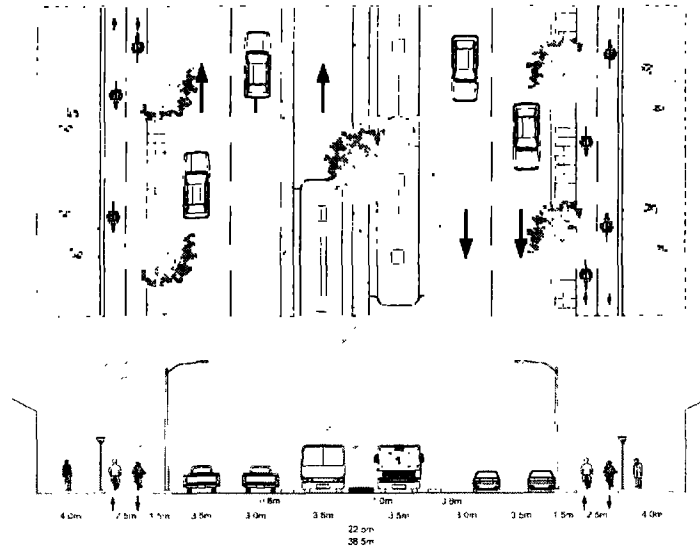

Figure 2.1.1.l
Stretch 5 – Cross Section off Station



Stretch 6 - Morogoro from Ubungo to Kibo, towards Kimara

The designed cross section is 42 m wide between stations and 48 m at stations, including pedestrian facilities and bikeway on both sides (see **Figures 2.1.1.m** and **2.1.1.n**). The proposed cross section will consist of the following items off stations:

- 2.5 m. wide bikeway on both sides of the road
- 6.5 m. sidewalks on both sides
- 1.5 m planting strip separating the bikeway from normal traffic
- 7.0 m. lanes per direction (2 lanes of 3.5 m) for mixed traffic on both sides
- 3.5 m. lane per direction for BRT vehicles between stations
- 1.0 m wide median strip separating the BRT vehicles in opposite directions
- 0.8 m wide median strip between bus lanes and private cars

At station sections, the proposed cross section is the following:

- 2.5 m. wide bikeway on both sides of the road
- 4.0 m. sidewalks on both sides
- 0.35 m wide median separating the bikeway from normal traffic
- 6.5 m. lanes per direction (1 lane of 3.5 m and another of 3.0 m) for mixed traffic on both sides
- 7.0 m. lanes per direction for BRT vehicles at stations
- 5.0 m. wide BRT station
- 0.5 m wide median strip between bus lanes and private cars

Figure 2.1.1.m
Stretch 6 – Cross Section at Station

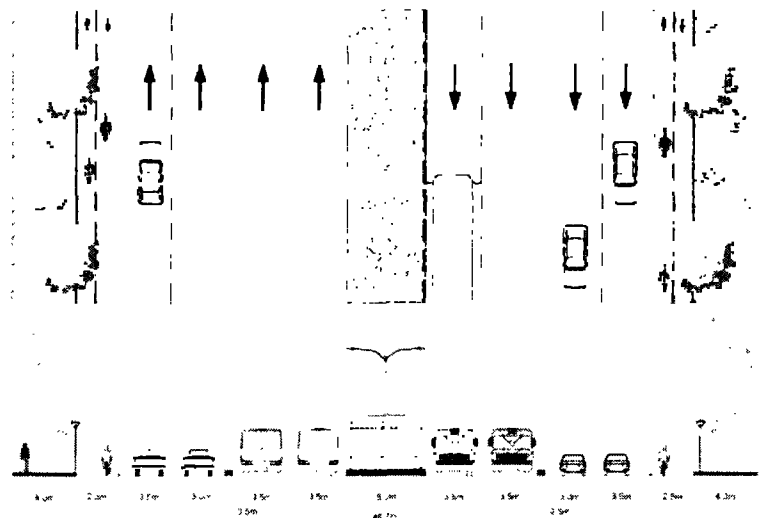
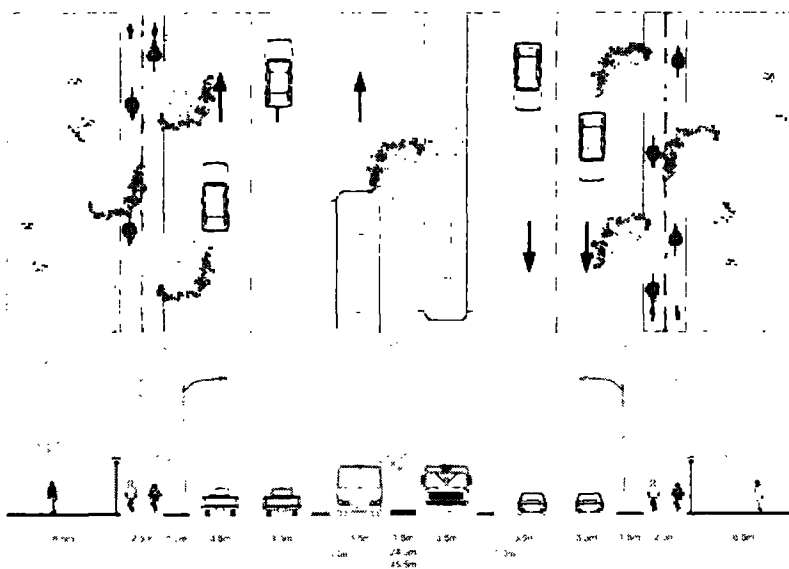

Figure 2.1.1.n
Stretch 6 – Cross Section off Station



Stretch 7 - Morogoro from Kibo to Kimara

As the demand on this stretch is smaller, the system can operate without the segregated lanes for BRT. Mixed traffic and DART buses will share two lanes and a third lane for overtaking buses and mixed traffic is provided at stations. Also sidewalks and walkways are reduced to adapt to the demand. The designed cross section is 22.9 m wide between stations and 34.4 meters at stations, including pedestrian facilities and bikeways on both sides (see **Figures 2.1.1.o** and **2.1.1.p**). It will allow using the existent open drainage system between stations. At stations it will be covered.

The proposed cross section consists of the following items off stations:

- 1.5 m. wide bikeway on both sides of the road
- 2.5 m. sidewalks on both sides
- 0.2 m wide median separating the bikeway from normal traffic
- 7.0 m. lanes per direction (2 lanes of 3.5 m) for BRT vehicles and mixed traffic on both sides
- 3.5 m. lane per direction for BRT vehicles between stations
- 0.5 m wide median strip separating the BRT vehicles in opposite directions

At station sections, the proposed cross section is the following:

- 1.5 m wide bikeway on both sides of the road
- 3.0 m sidewalks on both sides
- 0.2 m wide median separating the bikeway from normal traffic
- 3.5 m lanes per direction for bus stopping at both sides
- 6.5 m lanes per direction for BRT vehicles express lines and mixed traffic at stations
- 5.0 m wide BRT station
- no median strip between bus lanes and private cars

Figure 2.1.1.o
Stretch 7 – Cross Section at Station



Figure 2.1.1.p
Stretch 7 – Cross Section off Station

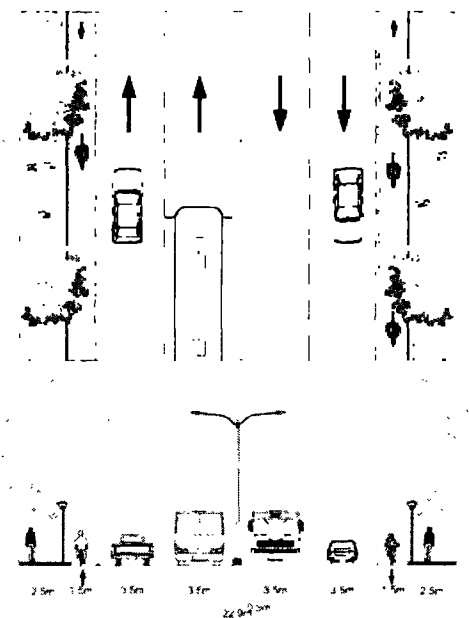

Stretch 8 - Kawawa Road branch

The designed cross section, including pedestrian facilities and bikeway on both sides is 37.1 m wide between stations and 41 meters at stations (see **Figures 2.1.1.q** and **2.1.1.r**). At stations, bikeways and walkways are reduced and off stations the proposed cross section is compatible with the existing one of approximately 37 m, thus avoiding as much as possible the properties along the corridor.

The proposed cross section will consist of the following items off stations:

- 2.5 m. wide bikeway on both sides of the road
- 4.0 m. sidewalks on both sides
- 1.5 m wide planting strip separating the bikeway from normal traffic
- 6.5 m. lanes per direction (2 lanes) for mixed traffic on both sides
- 3.5 m. lane per direction for BRT vehicles between stations
- 0.5 m wide median strip separating the BRT vehicles in opposite directions
- 0.3 m wide median strip between bus lanes and private cars

At station sections, the proposed cross section is the following:

- 1.5 m. wide bikeway on both sides of the road
- 2.5 m. sidewalks on both sides
- 0,2 m wide median separating the bikeway from normal traffic
- 6.5 m. lanes per direction (1 lane of 3.5 m and another of 3.0 m) for mixed traffic on both sides
- 7.0 m. lanes per direction for BRT vehicles at stations
- 5.0 m. wide BRT station
- 0.5 m wide median strip between bus lanes and private cars

Figure 2.1.1.q
Stretch 8 – Cross Section at Station

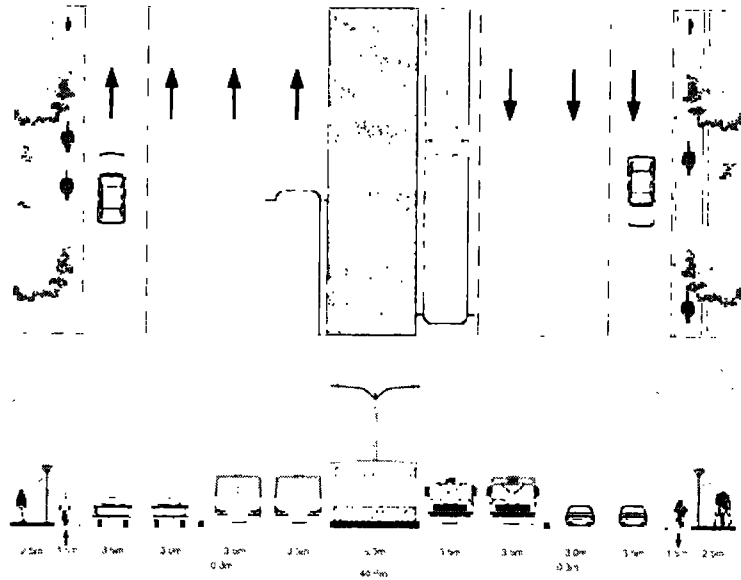
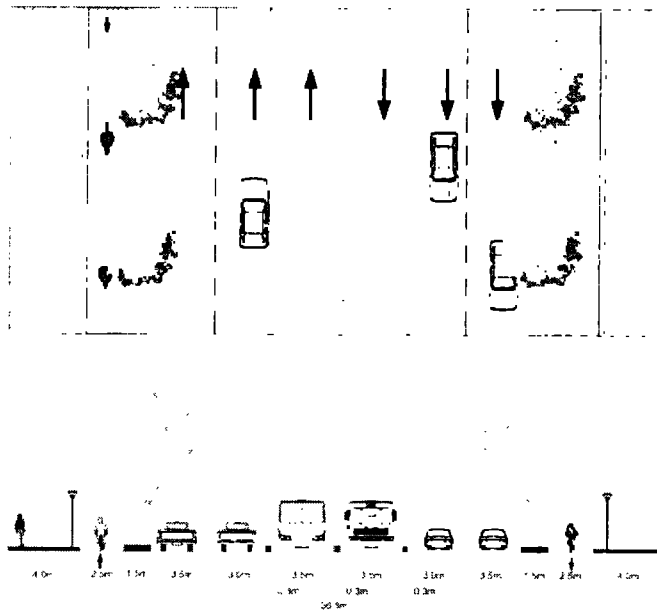

Figure 2.1.1.r
Stretch 8 – Cross Section off Station



Stretch 9 - Kawawa Road branch between Kinondoni A to Kanisani

This stretch crosses the Sinza valley and the cross section is designed to avoid as much as possible the earth work there. The designed cross section is 27.5 m wide including pedestrian facilities and bikeway on both sides (see **Figures 2.1.1.s** and **2.1.1.t**). No stations are proposed in this stretch. The proposed cross section will consist of the following items:

- 1.5 m. wide bikeway on both sides of the road
- 2.4 m. sidewalks on both sides
- 0.2 m wide median separating the bikeway from normal traffic
- 6.0 m. lanes per direction (2 lanes) for mixed traffic on both sides
- 3.3 m. lane per direction for BRT vehicles between stations
- 0.5 m wide median strip separating the BRT vehicles in opposite directions
- 0.3 m wide median strip between bus lanes and private cars

Figure 2.1.1.s
Stretch 9 – Cross Section at Station

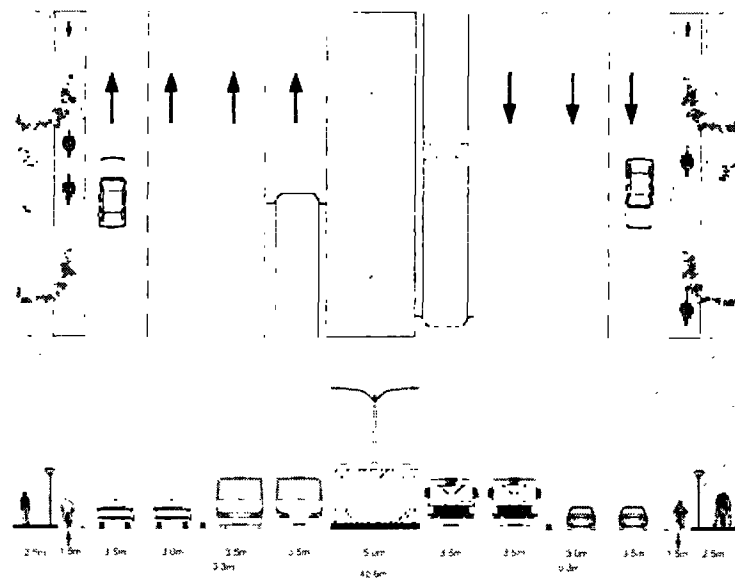
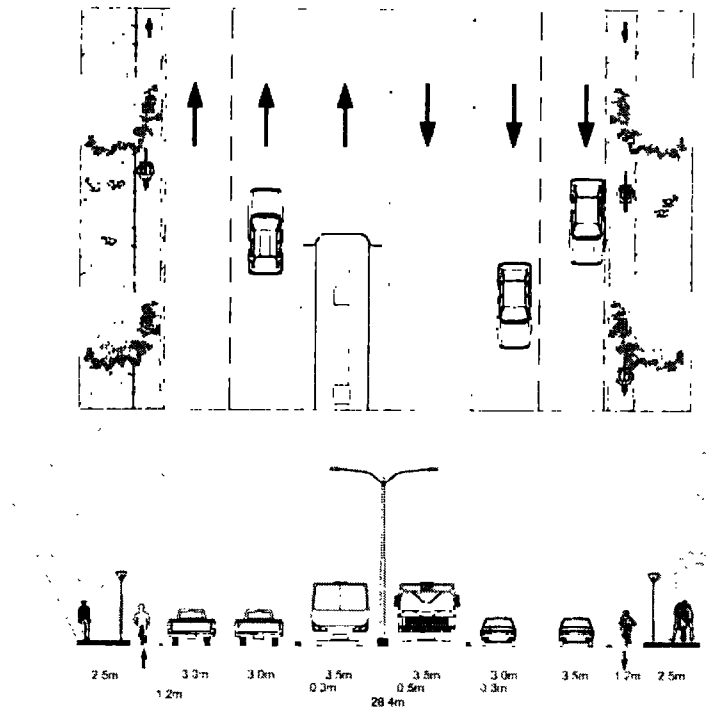

Figure 2.1.1.t
Stretch 9 – Cross Section off Station



Stretch 10 - Msimbazi Street branch

For Msimbazi Street, proposal is to use as much as possible existing roadway and walkways. As the corridor is very narrow, no bikeways will be provided and only one lane per direction will be provided for mixed traffic. Also, BRT will not have overtaking lanes at station.

The designed cross section is 20.5 m wide between stations and 24 m at stations, including pedestrian facilities on both sides (see **Figures 2.1.1.u** and **2.1.1.v**).

The proposed cross section will consist of the following items off stations:

- 2.5 m. sidewalks on both sides
- 3.0 m. lanes per direction for mixed traffic on both sides
- 3.5 m. lane per direction for BRT vehicles between stations
- 1.0 m wide median strip separating the BRT vehicles in opposite directions
- 0.3 m wide median strip between bus lanes and private cars

At the station sections, the proposed cross section is the following:

- 2.5 m. sidewalks on both sides
- 3.0 m. lanes per direction (1 lane of 3.5 m and another of 3.0 m) for mixed traffic on both sides
- 3.5 m. lanes per direction for BRT vehicles at stations
- 5.0 m. wide BRT station

Figures 2.1.1.u
Stretch 10 – Cross Section at Station

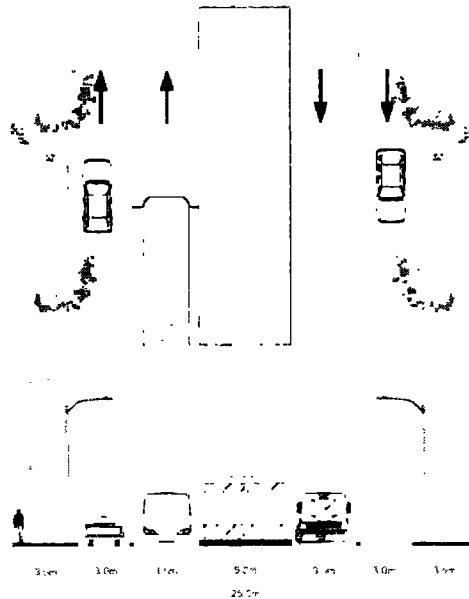

Figures 2.1.1.v
Stretch 10 – Cross Section off Station

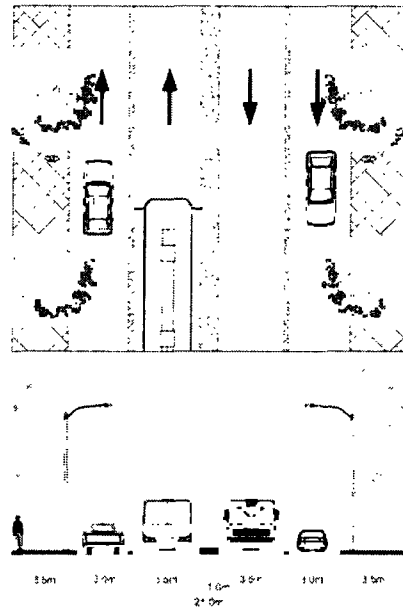
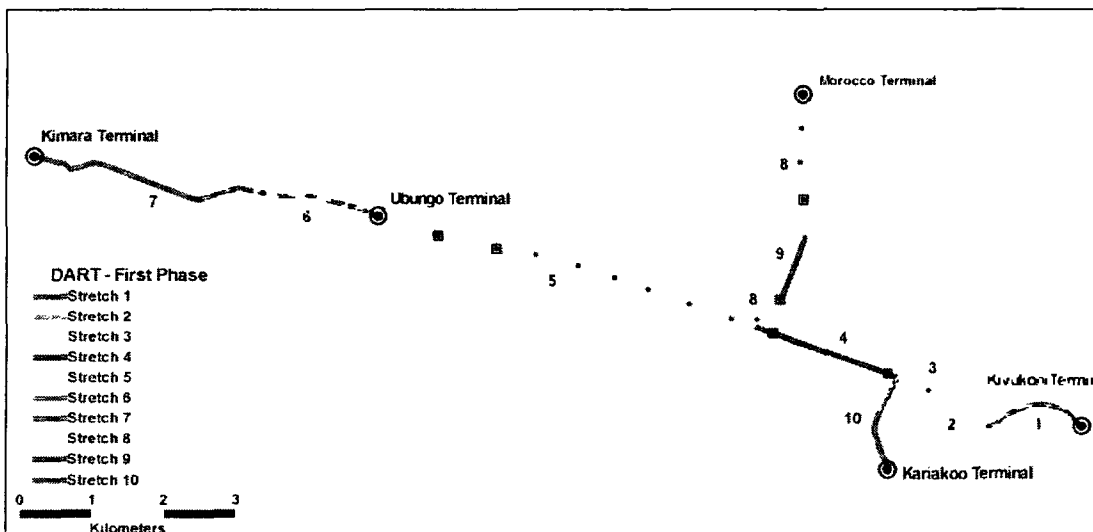

Figure 2.1.1.w indicates the distribution of the sections described above along the alignment of Phase I – Parts A and B of the BRT system.

Figure 2.1.1.w
Phase I – Parts A and B of the BRT system - Stretches



2.1.2

Bus Stations, Feeder Stations and Terminals

Bus stations and feeder stations have been strategically placed at points where a potential higher passenger movement would take place. Choice of station location also considered the existing bus stops along the projected corridor since they represent an existing landmark for public transportation users.

Designed stations have been classified according to their functionality and utility in two types. Conventional bus stations which are used by trunk services allowing passenger boarding and alighting, and feeder transfer stations. These last allow for the integration with one or more feeder routes and terminal stations. Besides passenger flow and feeder system integration, feeder stations are also start/end stations for trunk local and express services, and hence constitute great transfer points for the system. They are final stations allowing transfer between different transportation means such as the DART buses, regional buses, private vehicles and bicycles.

All stations and terminals, as well as buses, will have high platform floors at 90 cm above the roadway level allowing on-level boarding and alighting.

Bus Stations

Given the existing conditions and having in mind that in average people are willing to walk 300 meters to attend public transportation, stations will be located on average 500 m apart from each other. In some cases in which a station is not required due to insufficient affluence or because of physical constraints, this separation is increased, in other cases it is reduced.

Bus station design has focused on functional efficiency and adequacy, smooth circulation, universal passenger access, passengers' control, visual access, and, important natural cross ventilation to assure climatic comfort. The materials were chosen for durability, low maintenance, environmental friendship, and resistance to weather conditions.

Stations will be built by modules, each module with a capacity for 65 buses per hour per direction. The platform will be 36 meters long, enough to hold two stopping articulated buses.

Four types of bus stations are generated by the demand modelling. They may have one, two or three modules, depending on the demand. A module constitutes of 19 bays 2.4 m long with a constant width of 4.8 m from centre to centre. Stations with one module may have one side or two side entrances depending on the demand (types A and B), and stations with two or three modules (types C and D) will have entrances in both sides. The station types are as follows:

Station Type A

This station has a single module of 22 bays of 2.4 m instead with entrance only on one side with a total length of 55.6m including the ramp (see **Figure 2.1.2.a**).

Figure 2.1.2.a **Station Type A**

Station Type B

This station consists of a single module of 19 bays of 2.4m with entrance on both sides. Covering a total length of 72.8m including 2 ramps on either side (see **Figure 2.1.2.b**).

Figure 2.1.2.b **Station Type B**

Station Type C

This station has 2 modules of 19 bays of 2.4m with a separation of 36m between the modules. Covering a total length of 145.2m including 2 ramps on either side (see **Figure 2.1.2.c**).

Figure 2.1.2.c **Station Type C**

Station Type D

This station consists of 3 modules of 19 bays of 2.4m with 2 separators of 18m each between the modules. It covers a total length of 185.6 including 2 ramps on either side (see **Figure 2.1.2.d**).

Figure 2.1.2.d
Station Type D



Feeder Stations

The feeder stations defined are listed below, from east to west along Morogoro road and North to South along Kawawa road:

- Fire - station located between Msimbazi Street and United Nations road in front of Fire Department Station. The Fire - station has a feeder route connection with Muhimbili hospital.
- Magomeni Mapipa - situated before the intersection with Kawawa road on the same existing bus stand location. A feeder route connects this station with Kigogo Mburahati area.
- Urafiki Mahakama - located at the entrance street to Mabibo area. Feeder route offers coverage to this area.
- Shekilango - situated at Morogoro road and Shekilango road intersection it offers feeder routes with coverage on Sinza, Manseze, and Kijitonyama and Mwenge areas.
- Mwinyijuma - located along Kawawa road offers a feeder route to Mwananyamala and surrounding areas.
- Kinondoni A - located along Kawawa road this station integrates passengers from Makumbusho, Tandale and Manseze areas.

Characteristics of each feeder station can be verified in **Figures 2.1.2.e** through **2.1.2.j**.

Figures 2.1.2.e
Fire Feeder Station

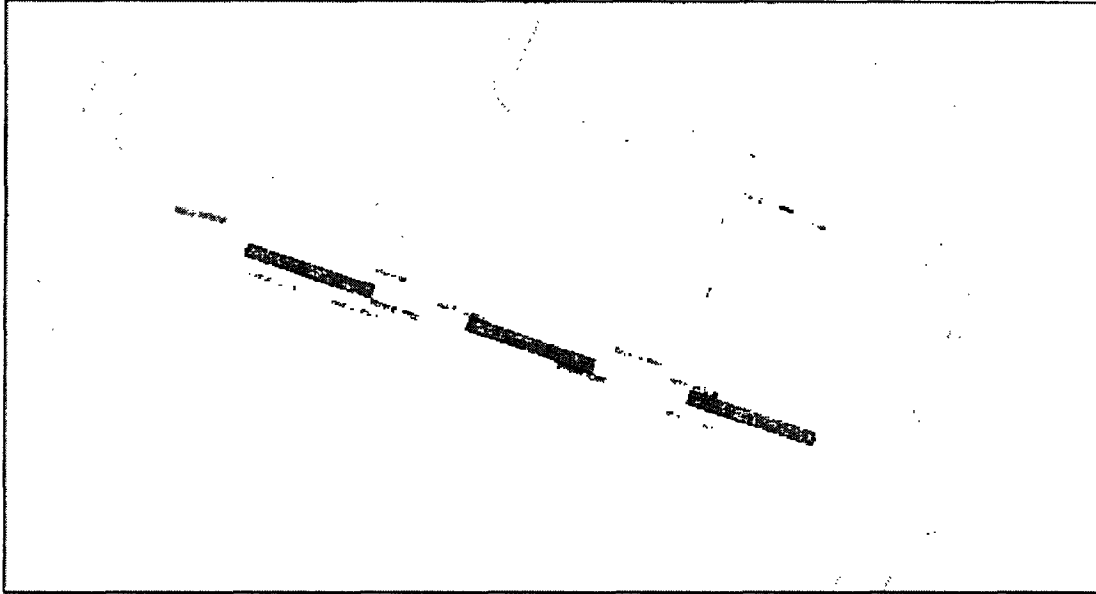

Figures 2.1.2.f
Magomeni Mapipa Feeder Station

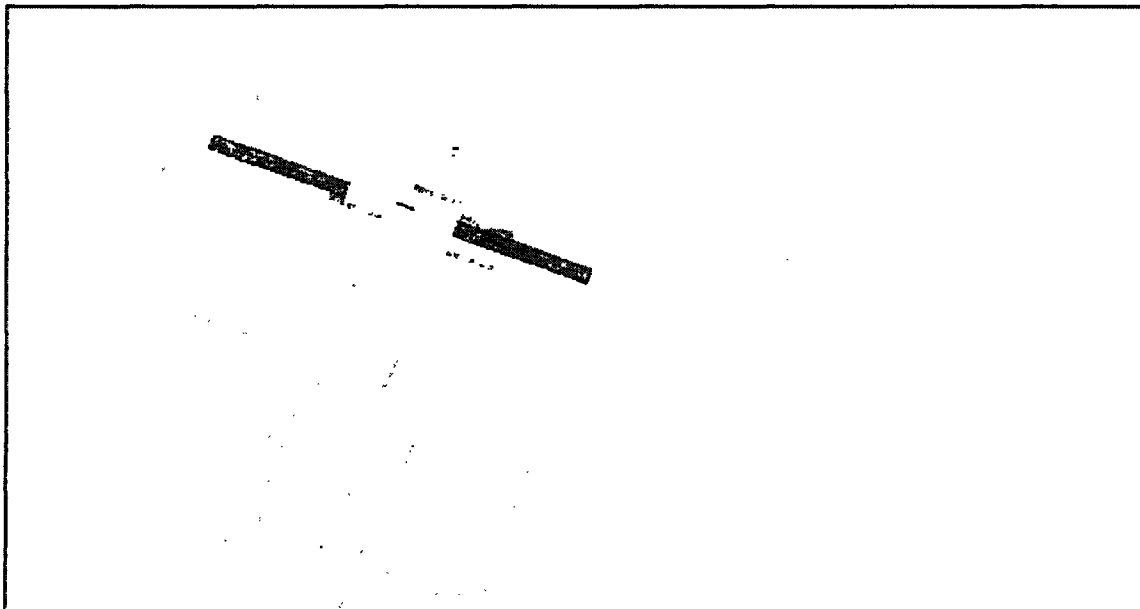

Figures 2.1.2.h
Urafiki Mahakama Feeder Station

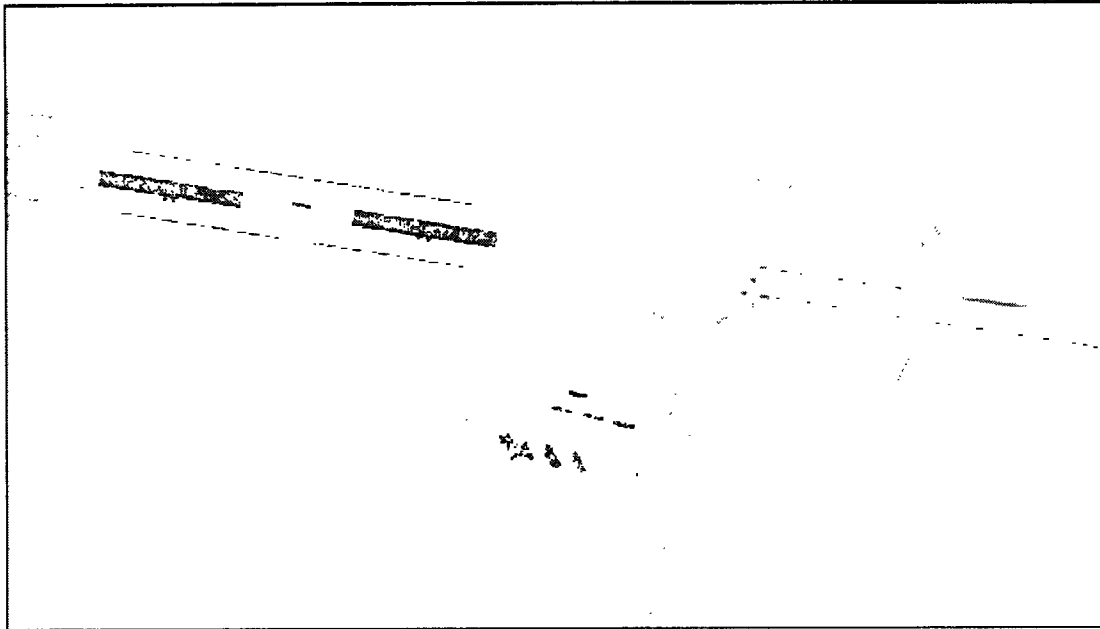

Figures 2.1.2.i
Shekilango Feeder Station

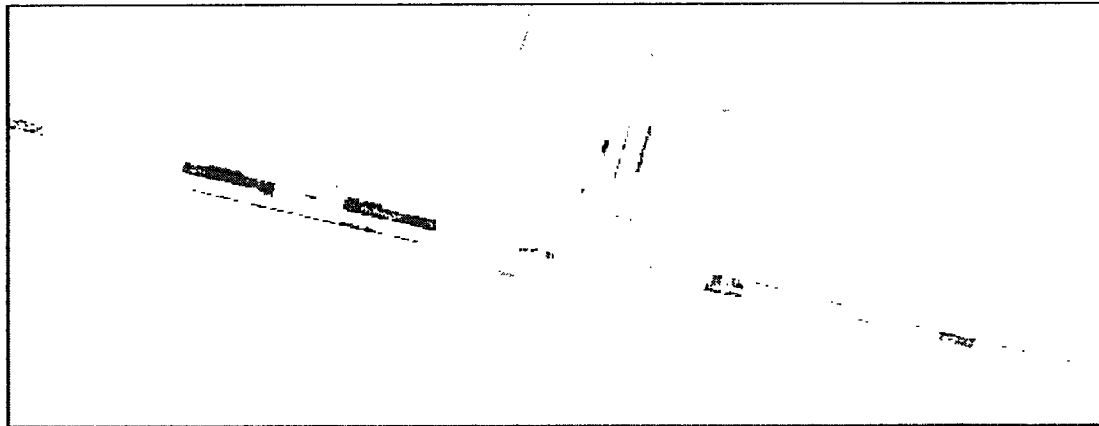

Figures 2.1.2.j
Mwinyjuma Feeder Station

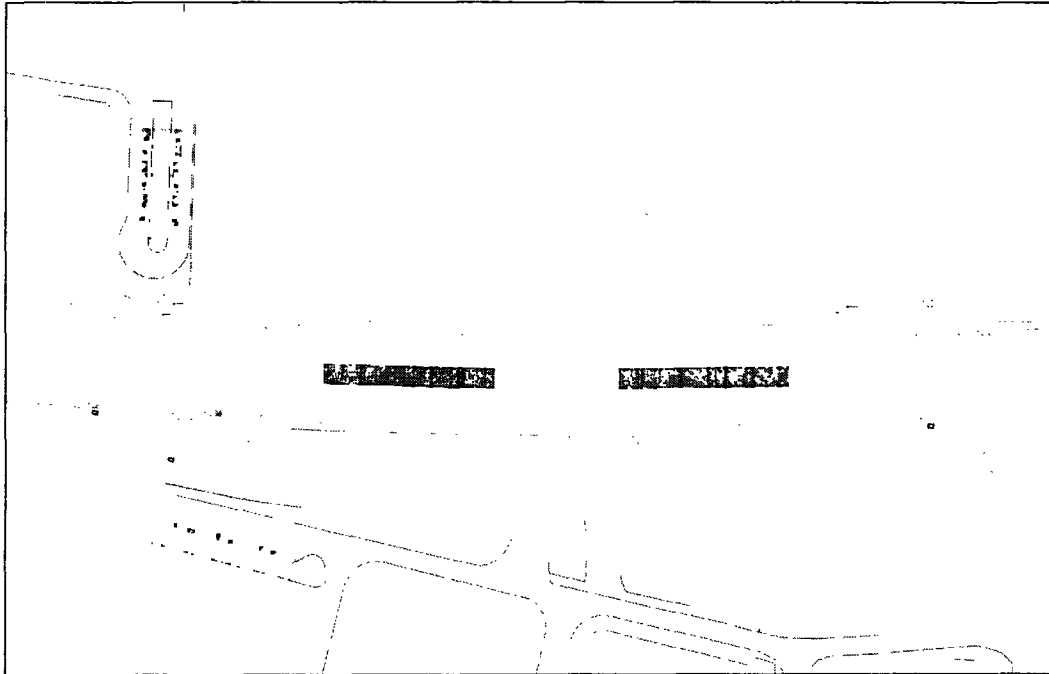

Figures 2.1.2.k
Kinondoni A Feeder Station

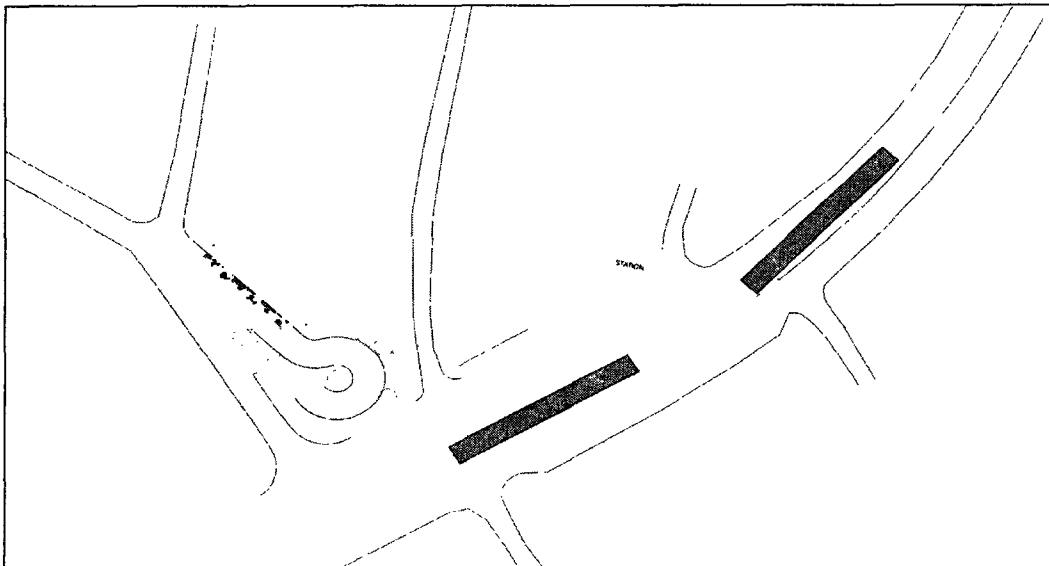

Terminals

The following criteria have been applied for locating terminal areas and defining general operational conditions:

- Corridor should be as long as possible so more passengers can benefit from BRT system, limiting transfer costs.
- Load on corridor links between terminals must be uniform avoiding operational costs of running empty buses.
- Terminals should be large and comfortable in order to allow different services and transportation means and to avoid transfer inside the corridor.
- Terminals need convenient size and accessibility, to avoid congestion and reduce distance traveled by feeder and trunk system users.

All these criteria cannot always be met and the choice at the end is usually based on:

- Location of existing terminals that are “natural” transfer points and usually satisfy some of the conditions above mentioned.
- Availability of areas near the corridor’s main axis.
- Major points of transit lines concentration.

There will be five (05) terminals in Phase I. Of these, four will be located at the ends of the corridor, that is, end of Kivukoni Front, end of Morogoro Road, end of Kawawa Road branch and end of Msimbazi Street branch. The fifth terminal, that will be the largest, will be located at Ubungo in an intermediate segment of Morogoro Road. Terminal locations are described below:

- Kivukoni Terminal – located at Kivukoni area next to Magogoni ferry port.
- Kariakoo Terminal – located along Msimbazi Street on the plot next to the railway and Nyerere road intersection.
- Ubungo Terminal – placed in front of Ubungo upcountry terminal (Stendi ya Mkoa) at the middle of Morogoro road axis. An additional development is being proposed for the plot now occupied by upcountry regional buses since the bus depot area is located at the area on the back of this plot. This area will additionally bring together a feeder terminal integrated to the main DART terminal, with feeder routes to Chuo Kikuu and Mwenge, upcountry bus terminal in a different layout and a proposed parking lot facility.
- Kimara Terminal – located at the end of Morogoro road corridor around the existing Kimara bus stand. It provides feeder routes integration to Msasani, Masaki, Kawe, Mikocheni, Kijitonyama
- Morocco Terminal – will be located at the intersection between Kawawa road and Bagamoyo road.

The proposed terminal locations are assessed in the table below on the basis of the previously specified location criteria.

Table 2.1.2.a
Terminal Location Evaluation

Terminal	Already a terminal?	Rational point?	How far form natural point?	Land acquisition required
Kimara	No	Yes	-	Yes
Ubungo	Yes	Yes	-	No
Morocco	No	Yes	-	No
Kariakoo	No	Yes	-	Yes
Kivukoni	Yes	Yes	-	No

In all terminals, commercial spaces have been planned at strategic locations within the layout. Main characteristics of each terminal are briefly described below:

Kivukoni Terminal

The Kivukoni Bus Terminal will be located on the Kivukoni front next to the Kigamboni Ferry Terminal. It will have a capacity for 80 articulated buses per hour (marked A in **Figure 2.1.2.k**).

A Daladala Terminal (marked B in **Figure 2.1.2.k**) is provided to integrate Dalala passengers to the BRT system. This terminal has a capacity for 12 routes and 252 vehicles per hour. Provision is also made for mixed parking (marked C).

These two terminals - for Daladalas and for BRT buses - occupy an area of approximately 16,500 m². There will not be fare integration within this terminal.

The proposed layout allows for inclusion of commercial boxes (about 5 m² each), distributed inside the terminal and also along the circulation areas. It will be possible to install 19 commercial boxes.

Figure 2.1.2.k
Kivukoni Terminal



Ubungo Terminal

The Ubungo Bus Terminal will be placed on the middle of Morogoro Road in front of the upcountry bus terminal. The platform will be 10 m wide, and have space for three platforms on each side. It will have capacity for 180 buses per hour (see **Figure 2.1.2.l**).

The terminal will be approached through an elevated pedestrian bridge, which will connect the sidewalks, the Feeder Bus Terminal and the new Upcountry Terminal - to be designed in a future project.

The feeder bus terminal will be located on the north side of the corridor, and, in the initial phase, two feeder routes will integrate to the BRT trunk system. The feeder terminal will have a capacity for 60 feeder buses per hour.

Besides the above installations, Ubungo terminal will accommodate a significant amount of commercial space, like restaurants, shops and boxes in view of reinstalling commercial activities that will be displaced along the corridor as a result of DART implementation. The proposed layout allows for installation of a total of 140 commercial boxes, of different typologies and sizes (5m², 10m², 15m²), distributed along the pedestrian overpass and attached to the feeder area. An

additional 87 boxes can be installed outside the terminal, as a future development proposal for the area.

Figure 2.1.2.m
Ubungo Terminal

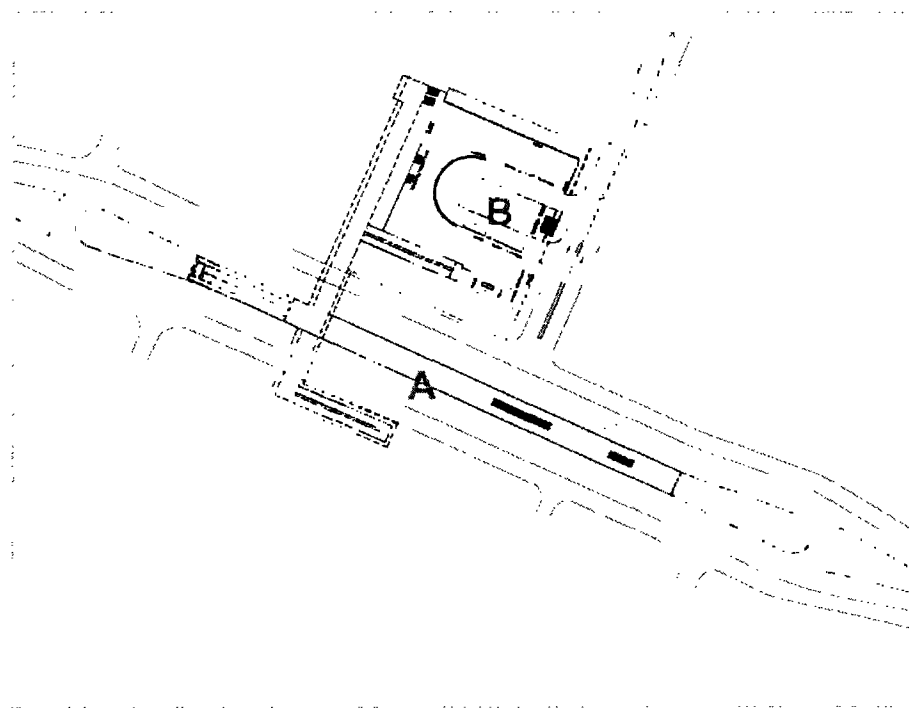

Kariakoo Terminal

The Kariakoo terminal will be implemented along Msimbazi Street. Implementation is planned to happen in two stages: the first stage will consist of a terminal platform and a platform for daladala vehicles (approximately 40). The second stage will contemplate the expansion of the terminal with the substitution of the daladalas by two more platforms.

Pedestrians will have access to the terminal through a central square joining the three platforms. At the pedestrian crossings there will be raised crosswalks, facilitating access to the platforms.

Total platform capacity will be four stops in the first stage and 24 in the second stage.

Internal circulation in the terminal will be exclusively for buses and will enable overtaking, thus optimizing traffic flow.

An area adjacent to the terminal is proposed for subsequent commercial development. This area can allow for installation of up to 226 commercial boxes which can accommodate some of the businesses to be displaced by corridor implementation. It must be noted, however, that development of this area requires expropriation of some residential buildings belonging to the TRC railway company and occupied by company employees. These could be resettled in a multi-storey buildings at the back side of the terminal, which is the solution planned for the employees occupying the houses to be removed for implementation of the terminal itself.

Figure 2.1.2.m
Kariakoo Terminal

Phase 1

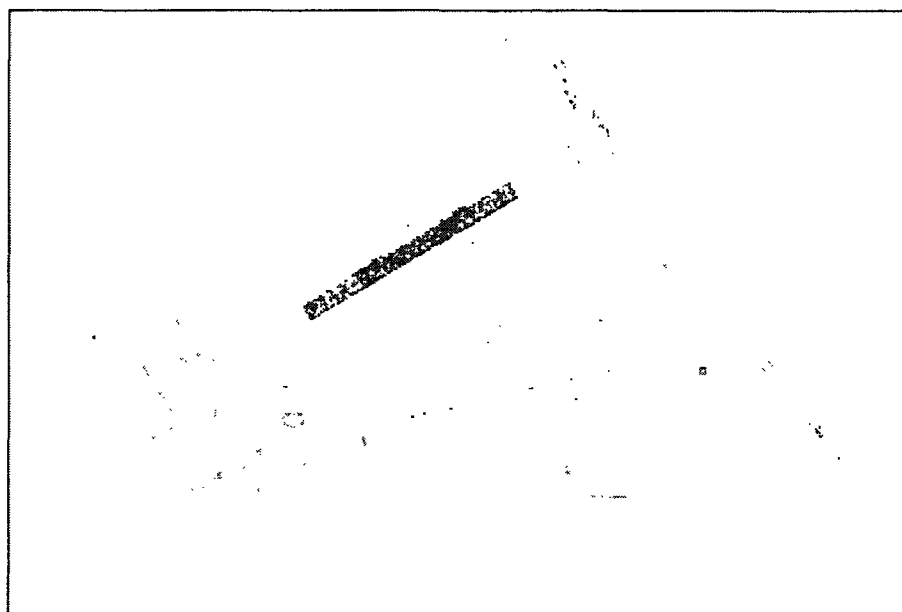

Phase 2 –



Morocco Terminal

The Morocco terminal will be implemented along the Kawawa Road axis. Within the terminal there will be a group of three feeder platforms with a capacity of nine micro-buses.

The feeders will be connected to the terminal by way of a footbridge reached by access ramps which will also connect both sides of the road.

The terminal platform will include three 45.8 m boarding/alighting modules with a capacity of twelve stops.

Terminal internal circulation will be exclusively for buses and will allow for overtaking.

A small commercial area within the terminal (along the overpasses), will have capacity for 14 commercial boxes.

Figure 2.1.2n
Morocco Terminal

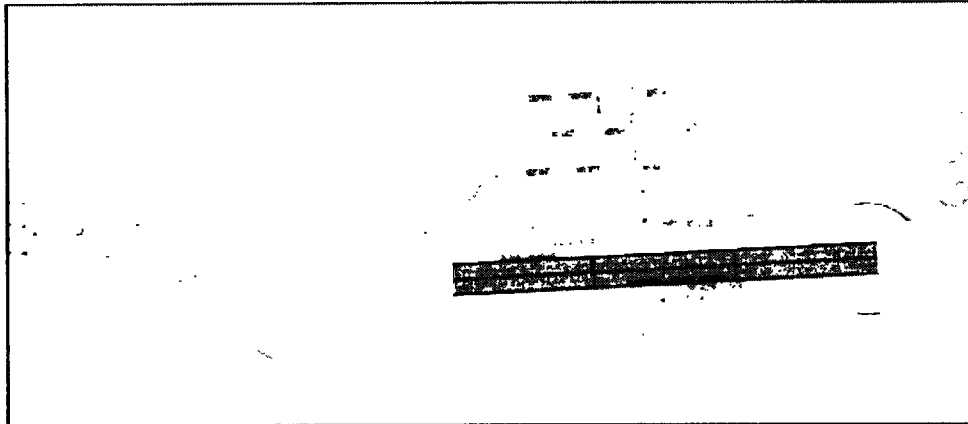

Kimara Terminal

Kimara terminal will be implemented along the Morogoro Road axis that will be altered to segregate local roads (outer lanes) from trunk bus expressways in the median strip.

Pedestrians will have access to the boarding/alighting platforms at the terminal by means of a footbridge reached by access ramps which also connect both sides of the road. All pathways will meet the standards of Universal Accessibility.

The terminal platform will include three 45.8 m boarding/alighting modules, with a carrying capacity of six stops. The platform will be divided along its longitudinal axis in order to group the daladala vehicles which leave towards the districts, beyond the corridor.

There are two operational U-turns, one for daladalas leaving towards the districts, and the other for DART trunk vehicles going downtown.

Interior terminal circulation will be used by both trunk vehicles and daladalas and overtaking lanes will be provided as necessary.

A small commercial area will be installed within the pedestrian overpass and will have capacity for 15 commercial boxes.

Figure 2.1.2.o
Kimara Terminal

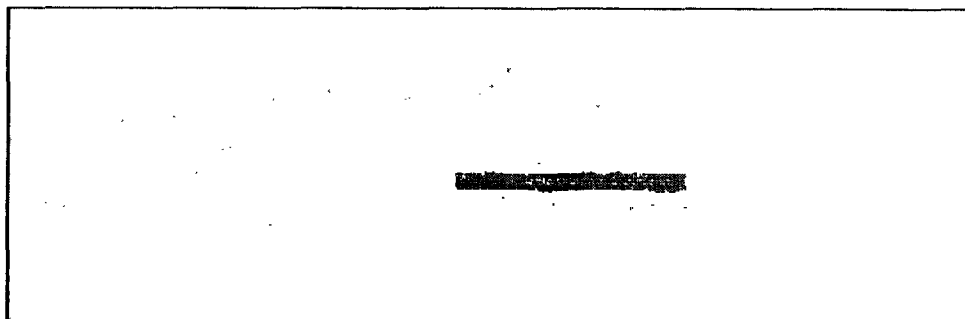

The table presented below consolidates information included in this section and presents the station/terminal inventory for DART's first phase.

Table 1.2.b
Phase I Stations and Terminals – DART System

DART Phase 1		
Station		
Corridor	Code	Name
Kawawa	7102	Kinondoni Mjini
Kawawa	7200	Mwinyijuma
Kawawa	7202	Kanisani
Kawawa	7300	Kinondoni A
Kawawa	7302	Usalama
Kawawa	8111	Morocco Terminal
Morogoro	10000	Kimara Terminal
Morogoro	10001	Kimara Resort
Morogoro	10002	Kimara Thomas
Morogoro	10003	Baruti
Morogoro	10004	Comer
Morogoro	10005	Kibo
Morogoro	10006	Chai Bora
Morogoro	10100	Ubungo Tanesco
Morogoro	10102	Ubungo Terminal
Morogoro	10200	Shekilango
Morogoro	10300	Urafiki Mahakama
Morogoro	10301	Tip Top
Morogoro	10303	Bakheresa
Morogoro	10304	Manseze Argentina
Morogoro	10305	Magomeni Kagera

DART Phase 1		
Station		
Corridor	Code	Name
Morogoro	10306	Mwembe Chai
Morogoro	10307	Baptist Church
Morogoro	10308	Magomeni Mapipa
Morogoro	10309	Jangwani
Morogoro	10311	Fire Station
Morogoro	10315	Libya Street
Morogoro	10318	City Council
Kiv Front	10322	Old Posta
Kiv Front	10324	National Bank
Kiv Front	10328	Bibititi
Kiv Front	10400	Kivukoni Terminal
Msimbazi	19002	Kariakoo Market
Msimbazi	19100	Kariakoo Terminal

	Conventional station
	Feeder Station
	Terminal / Bus Depots

2.1.3

Bus Depots and Maintenance Shops

The Ubungu Bus Depot will be located on the north area of the current Upcountry Terminal, and will have capacity for 100 articulated buses.

Figure 2.1.3.a
Ubungo Bus Depot

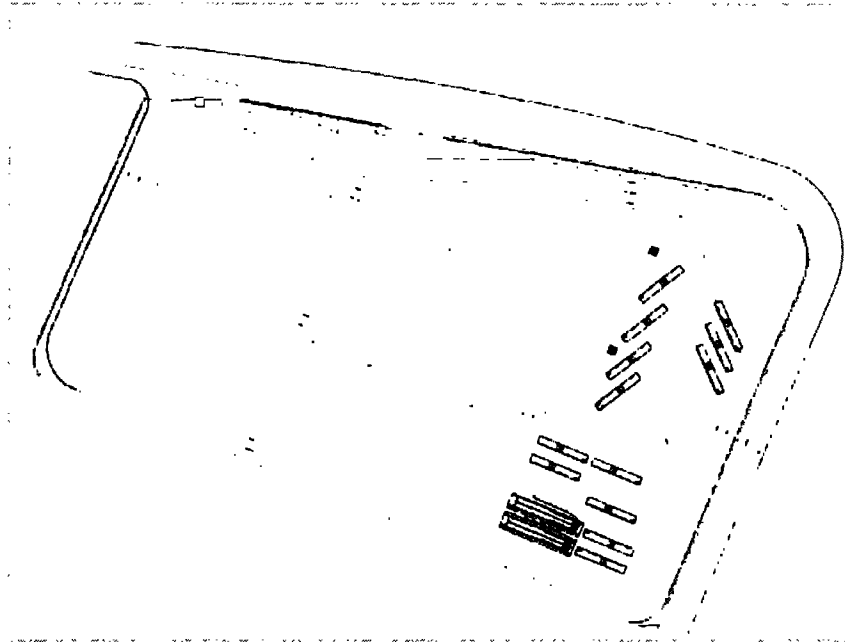

It will have an open parking place, divided into parking lots and two building blocks, one for administration and one for maintenance.

The Administration Building will accommodate personnel responsible for the management of the DART operations and will also have an area for provision of meals to employees.

The Maintenance Building will contain the workshop, storage room and all maintenance activities as follows:

- Workshop
- Storage room: designed to store replacement parts and necessary equipment for maintenance.
- Spare parts and piece cleaning area
- Area for mechanical support
- Air compressor and pumps repairing
- Battery room
- Electric spare parts repairing room.
- Small parts painting room
- Tire maintenance room
- Bus indoor maintenance

- External painting cabin
- Oil maintenance
- Cleaning and washing
- Air pumping pressure station, generator room and water tank.
- Toilets
- Maintenance offices.

A second Bus Depot will be necessary and its location is still under analysis. This facility will be similar to the depot at Ubungu, but will need to have capacity for only 60 buses.

Four alternative locations for the second Bus Depot are being studied and are discussed below.

Alternative 1 – Area between Nyerere Road and the railway line, near the proposed Kariakoo Terminal.

Figure 2.1.3.b
Alternative 1

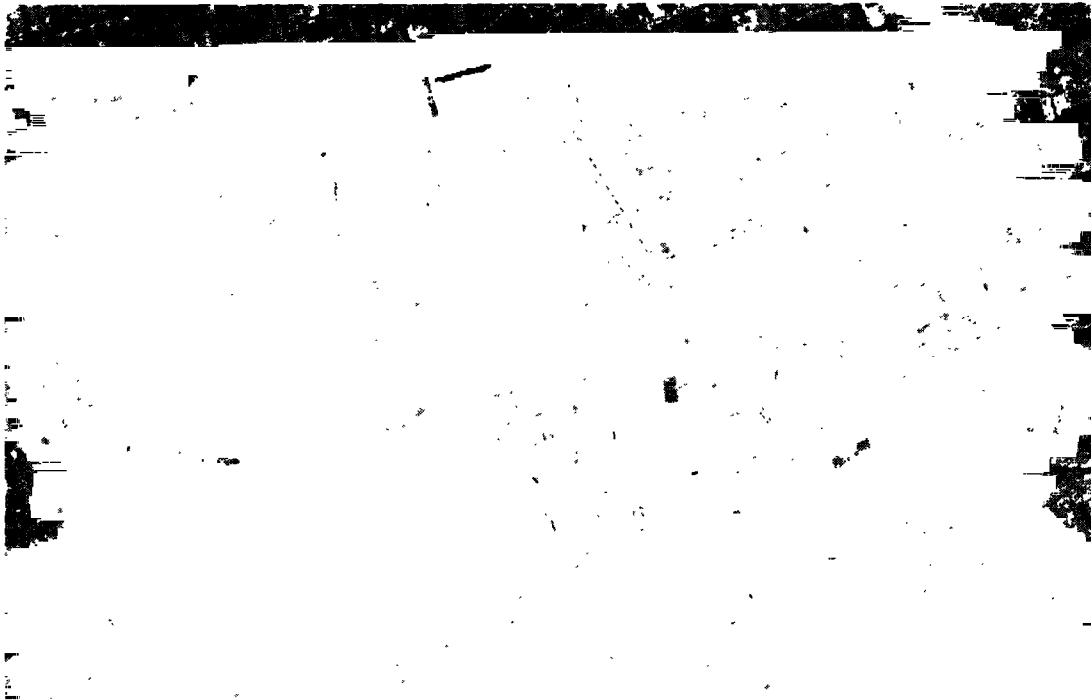

The advantages of using this area are:

- Availability of required space to accommodate the fleet of one bus operator
- Reduced social impact (no need for resettlement)
- Reduced environmental impacts
- Good accessibility for the articulated buses
- Good location in proximity of a corridor branch
- Surrounding area is already used for similar proposes

Whereas this area is very appropriate, ongoing legal disputes affecting ownership may render it unfeasible.

Alternative 2 - Part of the area in front of the University of Dar Es Salaam.

Figure 2.1.3.c
Alternative 2

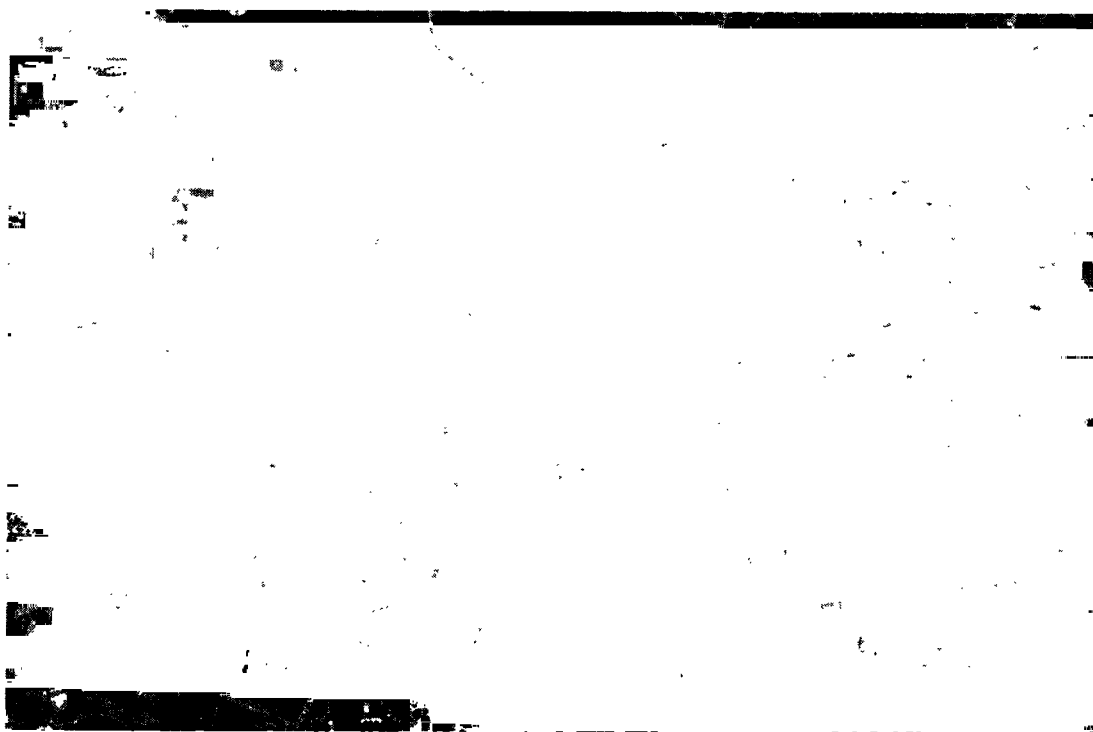

The advantages of this area are:

- Availability of required space to accommodate the fleet of one bus operator
- No need for resettlement
- Reduced environmental impacts
- Access roads adequate for the articulated buses

The disadvantages are:

- Distance from corridor makes this a less favored location in terms of operational costs
- If the assigned section of the plot is located far deep inside the area, (away from Sam Nujoma Rd), there will be need for earth movement

Alternative 3 – Biafra (Figure 2.1.3.d)

Figure 2.1.3.d
Alternative 3 – Biafra



The advantages of using this area are:

- Good location from an operational cost standpoint
- Access roads adequate for the articulated buses
- Favorable topography

The disadvantages are:

- High social impact since it is used as recreation area
- Land use conflict since it surrounded by noise sensitive impact receptors (a school and a university)

Alternative 4 – Area near Ubungo (**Figure 2.1.3.e**)

Figure 2.1.3.e

Alternative 4– Area near Ubungo

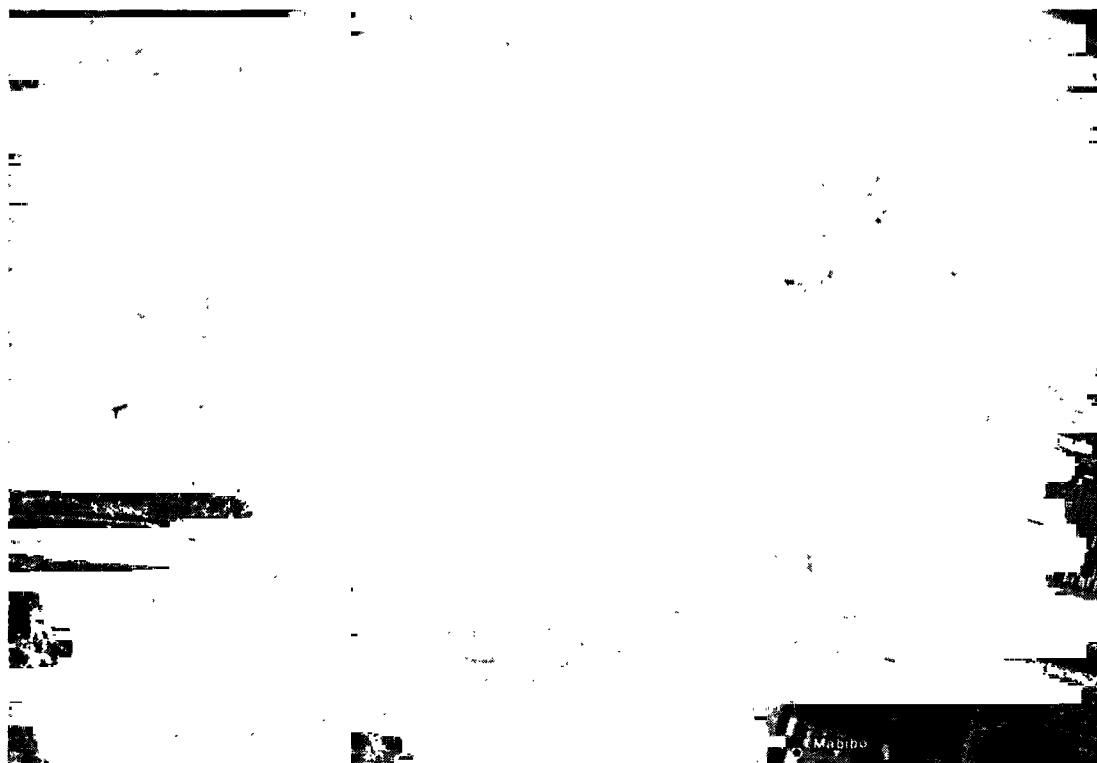

The advantages of using this area are:

- Reduced social impact (no need for resettlement)
- Medium environmental impacts

The disadvantages are:

- The area has already a developed project and may be difficult to acquire
- Not a good location from an operational cost standpoint
- Access for articulated buses will require improvements, including widening and paving a road and reinforcing a bridge
- May involve significant earth movement costs

The process for selection of the site for the second Bus Depot is under way and will be concluded shortly.

2.1.4

Intersections

A total of nineteen (19) intersections are planned as part of DART's Phase I - Parts A and B. These are briefly described below and have their schematic layouts illustrated in the **Annex 2**.

Traffic studies have confirmed that many intersections with 4-phased stop signs will regularly produce traffic bottlenecks because their capacity is more limited than that of the avenues reaching them.

The general approach towards intersection planning has been to eliminate or minimize right turn movements, thus transforming many 4-phase stop signs into 2-phase stop signs. This will increase time available for movements along the main avenues, decongesting the intersections without the need for fly-overs or other costly engineering works.

Movements that will no longer be allowed at the intersections have been displaced to U-turns at nearby locations.

Intersection 1 - Morogoro and Bibititi

This intersection works as a four phase junction and will be modified to operate as a two phase junction. No right turn will be allowed at this location. Right turning traffic will use returns and right turn lanes at other locations (Zanaki and Maktaba/Azikiwe). Traffic signals will operate with two phase cycles. Bibititi will continue to operate as a two lane divided roadway, no right turn will be allowed at this junction, however, Morogoro, in its southwest approach, will be completely dedicated to the BRT system. In the northeast approach, there will be one lane per

direction for the BRT and two lanes per direction for mixed traffic - between Bibititi and Lumumba. The traffic that currently uses the Morogoro segment between Bibititi and Sokoine will not be able to enter or exit the City Centre at this location. They will be able to do so using Zanaki, Maktaba/Azikiwe and Ohio. The intersections of Bibititi will be modified to allow traffic entering into the centre from both directions of Bibititi.

Intersection 2 - Morogoro and Lumumba

The traffic signal at this location will operate with a two phase cycle. In the northwest approach there will be one 3.3 m wide lane for the buses, two 6.5m wide through lane and one right turn lane for private vehicles. In the south east approach one 3.3 m wide lane for buses and two lanes per direction for private vehicles. Lumumba road will continue to operate as a two lane divided roadway, no right turn will be allowed at this junction.

Intersection 3 - Morogoro and Msimbazi

The Msimbazi intersection is the planned site for the most important passenger terminal of the system, the Kariakoo terminal. The junction will operate in a two phase cycle with the following movements:

- Northwest approach: two lanes for the BRT system: one through lane, one right turn lane, two lanes per direction for private vehicles.
- Southeast approach: one lane per direction for the BRT, two lanes per direction for mixed traffic.
- Southwest approach: one lane per direction for the BRT, one lane per direction for mixed traffic. Lanes for mixed traffic will not be continuous; they will end at the station by Pemba Street. Their purpose is to provide access to the Kariakoo area with only left in - left out movements allowed.

Intersection 4 - Morogoro and United Nations

The intersection will operate as a two phase junction. Along Morogoro, one lane per direction is provided for the BRT and two lanes per direction for mixed traffic. No right turns will be allowed at this junction. There are only two stations proposed in this segment, Bibititi Station and Fire Station.

Intersection 5 - Morogoro and Kawawa

No right turns for mixed traffic will be allowed at this intersection. However, since no crossing and side roads are available to be used for indirect right turns from Morogoro traffic, two U-turn intersections will be provided on Morogoro Road.

Right and left turning will be provided for BRT vehicles running south along Kawawa to Morogoro road (Morocco – Ubungo route) and Morocco – Kariakoo and Morocco - Kivukoni routes.

Intersection 6 - Morogoro and Mabibo

Two additional signalized intersections will be provided in the segment from Kawawa to Ubungo, one to provide access to neighbourhoods along Morogoro and another to enable returns, as indicated below:

- U-turn intersection for indirect right turns at the Morogoro/Kawawa junction.
- Return at intersection of Morogoro and Mabibo Road.

The operation at the first junction is a simple U-turn that could be granted upon detection of U-turn traffic demand.

The return at the second junction at Mabibo Road will work as a two phase intersection by utilizing the U-turns on both sides of Morogoro road. Right turning movement from North West approach to Mabibo will be prohibited. Traffic will have to get into the U-turn and wait for a signal before proceeding to Mabibo. Similarly traffic from Mabibo will not be allowed to make a right turn to Morogoro road, instead it will have to get into the South East U-turn and wait for a signal.

Intersection 7 - Morogoro and Shekilango

This junction will operate in two phase cycles with right turning movements. The right turning vehicles store at a bay. The signal at Shekilango will operate in two phase cycles. Both signals must be perfectly coordinated, with signal 2 operating with half the cycle of signal 1. A feeder station is proposed at Shekilango road near the existing petrol station.

Intersection 8 - Morogoro and Mandela/Sam Nujoma Junction

The junction which is currently functioning as a four phase junction will be modified to work as a two phase junction. No right turn will be allowed at this location. Right turning traffic will have to use U-turns. The U turns will be signalized and they will be provided along Sam Nujoma Road and Mandela Road. Traffic signals will operate with two phase cycles. Sam Nujoma road and Mandela road will continue to operate as two lane divided roadway.

Intersection 9 – Kawawa and Bagamoyo/Ali Hassam Junction

This intersection currently operates with a four phase signal plan, which is sometimes overridden by a police officer, who controls movements during peak periods. After the BRT corridor is implemented, a two phase signal plan will be adopted and right turns will be prohibited. The right turning traffic will use U-turns located on Kawawa Rd., North and South from Kawawa/Bagamoyo intersection. U-turns will be operated with a two phase signal plan.

Intersection 10 – Kawawa and Dunga Junction

The intersection of Kawawa and Dunga is currently not signalized, but in the future will operate according to a two phase traffic signal plan. The first phase is for through movements on Kawawa Rd. and left turns from Kawawa Rd. to Dunga St. Right turns will be transformed into a sequence of left turns plus through movements (Kawawa to Dunga) or through movement plus left turns (Dunga to Kawawa). The through movements will be performed during the second phase defined for this traffic signal.

Intersection 11 – Kawawa and Kinondoni Junction

Kawawa and Kinondoni Junction is a T-intersection, with 2 approaches for Kawawa and one westbound approach from Kinondoni. This intersection currently operates with a three phase plan. During peak hours, the operation is always jammed due to the conflicts between through movements on Kawawa and right turns from Kawawa to Kinondoni and from Kinondoni to Kawawa. The proposed operation for the future is a two phase signal plan, one phase for Kawawa and the second one for Kinondoni. Right turns from Kawawa to Kinondoni will be prohibited, in such a way that right turners will have to perform left turns around the block located West of Kawawa and cross this road at Mwinyjuma intersection.

Intersection 12 – Kawawa and Mwinyjuma Junction

Kawawa and Mwinyjuma Junction is also a T-intersection with northbound and southbound approaches for Kawawa and one eastbound approach for Mwinyjuma St. This intersection functions with a three phase signal plan similar to Kinondoni's intersection, and has also poor levels of service during peak hours due to conflicts between right turns and through movements. For this intersection, a two phase signal plan is proposed with one phase for Kawawa and the other one for Mwinyjuma. Right turns from Kawawa will be performed by a sequence of left turns plus crossing movement on Kinondoni intersection. Thus, Kinondoni and Mwinyjuma intersections will be part of a network system design for all kinds of movements.

Intersection 13 – Kawawa and Malongwe Junction

Kawawa and Malongwe Junction is currently non-signalized but will be when the BRT corridor is implemented. The plan proposed for this intersection is a two phase plan, with one phase for Kawawa and another phase for Malongwe. Right turns from Kawawa to Malongwe will be performed by left turns plus through movement crossing Kawawa during second phase. It should be noticed that some expropriation will be necessary on properties near this intersections in order to construct new streets, which will complement the existing roadway system.

Intersection 14 – Kawawa and Mlandizi Junction

Kawawa and Mlandizi Junction is currently non-signalized but will be when the BRT corridor is implemented. The plan proposed for this intersection is a two-phase plan, with one phase for Kawawa and another phase for Mlandizi. Right turns from Kawawa to Mlandizi will be performed by left turns using Chemchem St. followed by a through movement crossing Kawawa during second phase.

Intersection 15 – Msimbazi and Swahili Junction

The intersection of Msimbazi and Swahili Sts. is currently non-signalized, but will operate with a two phase traffic signal after the construction of the BRT corridor on Msimbazi St. Phase 1 is proposed for movements on Msimbazi and phase 2 for vehicles coming from Swahili St. The system of side and cross streets will have to be used to accommodate right turn vehicles, since this type of movement will not be allowed in a two phase scheme.

Intersection 16 – Msimbazi and Mafia Junction

The intersection of Msimbazi and Mafia Sts. is non-signalized like Swahili St. After the implementation of the BRT corridor on Msimbazi St., this intersection will be signalized with a two phase traffic signal. Phase 1 is going to be used for movements on Msimbazi and phase 2 is going to be used by vehicles coming from Mafia St. The system of side and cross streets will have to be used to accommodate right turn vehicles, since this type of movement will not be allowed in a two-phase scheme.

Intersection 17 – Msimbazi and Uhuru Junction

The intersection of Msimbazi St. with Uhuru St. is a roundabout currently operating with stop signs. In the future, the central island of the roundabout will be cut in the direction of Msimbazi St. to accommodate two BRT lanes. Even though the traffic analysis for this intersection has not been completed, a two phase traffic signal will probably be implemented to control the traffic movements on the new functional design.

Intersection 18 – Msimbazi and Lindi Junction

Msimbazi and Lindi Junction is currently a non-signalized intersection which will operate with a two phase traffic signal plan. One phase will be dedicated to movements coming from Msimbazi and another one for movements originated on Lind St. To perform right turns on this intersection, vehicles will have to turn around blocks in a sequence of left turns plus through movements for crossing.

Intersection 19 – Msimbazi and Nyerere Junction

Msimbazi and Nyerere is a four phase signalized intersection, with phases for right turns from Nyerere to Msimbazi. During peak periods, a traffic officer controls the traffic movements, overriding the traffic signal plan and providing a sequence of two phases for Nyerere Eastbound approach on each cycle, in comparison to one single phase dedicated to other approaches. With the future operation of the BRT corridor, it is proposed that this intersection functions as a two phase signal plan, being one phase for Msimbazi and another one for Nyerere. Right turns at this intersection will be performed at U-turns implemented on both approaches of Nyerere St.

2.1.5

Pedestrian Crossings

On-level pedestrian crossings with associated traffic calming devices will be provided at all bus stations and feeder stations as necessary. At terminals where expected pedestrian traffic is more significant, elevated pedestrian walkways have been planned, as follows:

- Ubungo Terminal – elevated walkway over Morogoro road, linking the terminal to the feeder station.
- Morocco Terminal - elevated walkway over Kawawa road, linking the terminal to the feeder station.
- Kimara Terminal - elevated walkway over Morogoro road, linking both sides of the road to the terminal and the feeder station.

2.1.6 Bridges and other Special Structures

One existing bridge of approximately 50 m long at Msimbazi river crossing, and three box culverts will need to be widened to allow for widening of Morogoro road. There will also be a large quantity of earth work (fill and cut) in this segment. Furthermore, the box culvert at the crossing of Kawawa road over Sinza river will need to be extended in order to allow for widening of the street. These are relatively minor engineering works that can be executed without the need for provisional water deviation or other similar type of intervention in the river bed.

The project also includes the construction of five retaining walls, three of them of reinforced concrete, varying from 0.70 m to 2.5 m high, located at the Kivukoni front, one gravity retaining wall with 3.5m high, perpendicular to road alignment, located nearby the junction to Lumumba St, and one gravity retaining wall, with height varying between 1.0 m to 2.5 m, after the Jangwani valley.

The project does not include any other special structure of significant size. As mentioned in Section 2.1.4, fly-overs have thus far not been included in the intersection designs. Major engineering works associated to DART implementation are road pavement reconstruction (and reinforcement), and civil works at stations and terminals.

2.1.7 Corridor Pavement

The methods used for the original construction of the existing roads were based on non-traditional methods and local materials. Four alternative rehabilitation and reinforcement options, including recycling of asphaltic materials, are considered. They are all based on maximum use of existing and local virgin materials to minimize haulage and construction costs.

**Table 2.1.7.a
Pavement Rehabilitation Options**

Option 1	Reconstruction using thick hot mixed asphalt for mixed traffic and reinforced concrete grade 30 in all BRT bus lanes directly on the existing stabilized base
Option 2	Reconstruction using less hot mixed asphalt thick crushed rock base course for the mixed traffic and reinforced concrete 30 in all BRT bus lanes
Option 3	Reconstruction using a combination of hot mixed asphalt and cold in-situ stabilization of existing sub base sand according to the "foam mix" method for the mixed traffic lanes and reinforced concrete grade 30 for the BRT bus lanes.
Option 4	Construction of all BRT bus lanes and overlaying the remaining sections to cater for mixed traffic

The most efficient solution was found to be Option 1, taking into account the following criteria:

- Condition of the existing pavement
- Strength requirements for the new pavement
- Types of materials in the existing pavement
- Available materials for construction of the new pavement
- Required surface levels of the new road
- Construction practicalities
- Cost

2.2

Project Construction Planning

Construction of DART – Phase I – Parts A and B will be tendered during 2007. Detailed pre-construction planning will only take place after contractors are selected. Nonetheless, some key aspects of construction logistics and support infrastructure can already be defined, particularly as they affect environmental and social aspects.

2.2.1

Construction Schedule

Current plans are for simultaneous implementation of Parts A and B of Phase I of the DART project. A phasing strategy will be adopted in order to reduce impacts on traffic during construction, particularly since, with the exception of the Central Business District, there can be no traffic diversion during construction due to lack of alternative roads.

The general strategy will be to build extra lanes and keep shifting traffic to completed lanes as construction advances.

Traffic reorganization of the CBD will be implemented prior to construction in order to liberate space for building the initial Morogoro Road stretch (from City Council do Bibi Titi), Sokoine Drive and Kivukoni Front.

Corridor construction will be divided into four main stretches with partially overlapping schedules:

- First stretch - includes the segment from Kivukoni terminal to station 2+900 and Msimbazi St.
- Second stretch - includes the segment from station 2+900 to station 07+600.
- Third stretch - starts at station 07+600 and ends at Kimara Mwisho.

- Fourth stretch - Kawawa Road.

It is assumed that the construction companies will work in corridor sections covering two stations at each time.

Flexible pavement lanes will be constructed in two stages, initially completing the base and leaving the top finishing for later. Rigid pavement lanes will be built in a single stage procedure.

Walkways and bikeways will be built at the same time as the rest of the corridor pavement, following the strategy set for each stretch. Station platforms will be built also at the same time as the rest of the corridor pavement.

Terminals, feeder stations and bus depot construction will proceed simultaneously. Signaling and landscape will be the final step of construction, together with assembly of bus station structures.

Total construction time is estimated at 18 months, as per the General Construction Schedule presented below.

Table 2.2.1.a
General Construction Schedule

Construction / Months	1	2	3	4	5	6	7	8	9	10	11	12	13	14	15	16	17	18
Stretch 1																		
Stretch 2																		
Stretch 3																		
Stretch 4																		
Intersections																		
Bridges and others structures																		
Secondary roads																		
Feeder Stations																		
Terminals and Bus Depots																		
Stations																		
Signaling and Landscape																		

2.2.2

Construction Labor Requirements

Average labor requirements are estimated at 300 workers, including 230 direct and 70 indirect. During peak months, construction labor is expected to reach 480 workers (380 direct and 100 indirect). Peak conditions will last approximately 5 months. The chart below

illustrates expected construction labor requirements during the 18 month construction schedule.

Figure 2.2.2.a

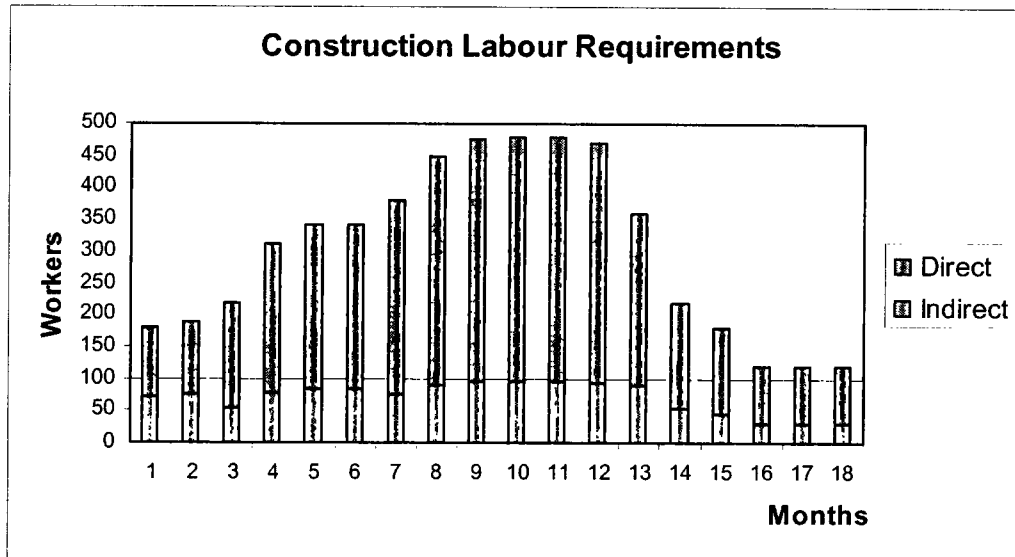

It is expected that approximately 80% of direct labor and 50% of indirect labor may be recruited locally, with the remaining positions being occupied by expatriate workers, technicians, engineers and management staff. Thus, Phase I – Parts A and B of the project will employ up to 360 local workers during peak months, and will involve a total of up to 130 expatriates.

2.2.3

Construction Materials Sourcing

Construction materials necessary during construction will include:

- Gravel materials
- Hard stones
- Sand

An investigation into possible sources for those materials resulted in identification of eight sites with capacity that exceeds DART Phase I construction needs. Most of those sites are ongoing commercial operations.

The table below shows the details of borrow pits and quarry location and materials characteristics. Materials Sourcing Technical Data Sheets included in **Annex 3** provide further information.

Table 2.2.3.a
Borrow Pits and Quarry Location and Materials Characteristics

Borrow Pit	Location	Type of Material	Quantity Available
Bunju Moyofoka	22.1 Km. from Mwenge Junction	Gravel	350,000 m ³
Bunju A	25.35 Km. from Mwenge Junction	Gravel	200,000 m ³
Mpiji River	27.15 Km. from Mwenge Junction	Sand	100,000 m ³
Kimani	20.5 Km. from Tazara Junction	Gravel	90,000 m ³
Dondwe Mkuranga	41.35 Km. from Tazara Junction	Fine Sand	120,000 m ³
Mjimwema	8.2 Km. from Kigamboni	Clayey Sand	220,000 m ³
Minaki	30.95 Km. from Tazara Junction	Gravel	100,000 m ³
Lugoba Quarry	139 Km. from Dar Es Salaam	Granite Rock	250,000 m ³

As can be verified in the table above, construction materials with adequate characteristics can generally be found within 50 Km. of the project. The main exception is rock that will need to be brought from a quarry 139 Km. from Dar Es Salaam.

2.2.4

Construction Support Infrastructure

DART implementation will require the following support infrastructure:

- Dump sites for excess material (soil) not compensated through cut and fill earth movement along the alignment.
- Dump sites for demolition debris.
- Controlled disposal site for contaminated soil.
- Construction camp facilities, including administrative installations, maintenance workshops, carpentry, materials and spare parts storage, vehicle and equipment parking.
- Provisional industrial facilities, including at least an asphalt plant and a concrete plant.

Whereas definitive location and characteristics of construction support infrastructure cannot be specified at this point in time, some preliminary definitions are presented below.

Dump sites for excess material (soil)

Excess soil may be generated along several segments of the works where project geometry does not allow for full compensation of cut and fill. In some cases such as flood plain crossings, soil substitution may be necessary in order to guarantee proper structural conditions.

The precise amount of excess soil to be taken to dump sites cannot be established at this stage of the project's engineering.

Dump site(s) will be selected on the basis of topography (preference for flat areas), drainage (distance from rivers and streams), vegetation (absence of forest cover), and property (non interference with communal lands and preference for publicly owned or single owner areas).

Logistically, dump site(s) will be located along the routes to the sites where construction materials are being sourced from (see Section 2.2.3), thus utilizing back-haul capacity of trucks. In some cases, it may be possible to dump excess soils at the sites from where construction materials are sourced.

ump sites for demolition debris.

Demolition debris will be disposed of in a special dump site. Consultation between the City Council and local municipalities is proceeding in order to establish a preferred location. Demolition debris may be disposed of at municipal landfill sites depending on current conditions. Otherwise, a special site will be selected.

Special care will be taken during disposal of debris in order to ensure future stability of the dump site.

Controlled disposal site for contaminated soil.

The project will affect several petrol stations and underground tanks will need to be removed. On the basis of current conditions at those stations, it is expected that some contaminated soil will be found. This will need to be removed to a special site where an impermeable base and dikes effectively contain all contaminated material and avoid impacts on groundwater quality.

Responsibility for contaminated soil belongs to the petrol station owners. However, appropriate sites for disposal of oil contaminated soils do not exist in Tanzania and the DART project's construction schedule cannot wait for a solution to this problem. Therefore, a special landfill site will need to be engineered and implemented at a location that will be determined by the Dar Es Salaam City Council. Commercial agreements with the petrol station owners will ensure that the costs of this installation are properly distributed.

Construction camp facilities

Construction camps will need to include basically administrative and equipment maintenance and parking facilities. No worker dormitories are planned since mostly local labor will be used and expatriates will most probably be housed in rented apartments near the construction fronts.

Dar Es Salaam has a wide variety of industrial sites that can be rented by construction companies, as well as other strategically located urban plots with adequate access and infrastructure. Camp location will be defined by the selected contractors at a later date.

Provisional industrial facilities, including at least an asphalt plant and a concrete plant.

Construction of DART Phase I pavements will probably require implementation of at least one concrete plant and an asphalt plant to operate exclusively for the project. These may be portable facilities that are relocated several times during the 18 month construction schedule.

Complementarily, if any existing commercial operations are able to supply concrete or asphalt to the project they may also be involved.

All provisional industrial plants will be required to operate with particulate matter filters. Notwithstanding, site selection criteria will avoid proximity with residential areas, schools and other similar facilities, particularly in the case of the asphalt plant.

2.3

Project Investment Cost

Total estimated project investment cost is TZS 129,876,688,512.00 equivalent to US\$ 108,230,574.00 at an exchange rate of 1,200.00 TZS/US\$. Of this, TZS 69,334,265,362.00 (US\$ 57,778,554.00) corresponds to Phase I – Part A, and TZS 60,542,423,150.00 (US\$ 50,452,019.00) to Phase I – Part B.

The table below shows estimated investment costs by major cost categories. As can be seen, road reconstruction and reinforcement along the corridor's alignment is by far the most significant item, representing almost 49% of total investment. Stations and terminals are also very significant and jointly represent almost 20% of investment.

Table 2.3.a
Estimated Investment Cost

ITEM	AMOUNT (TZS)	AMOUNT (US\$)
Stations – Part A (Pilot Corridor)	6.976.252.624	5.813.544
Stations – Part B (Extension)	6.252.429.194	5.210.358
Terminals - Part A	5.199.213.050	4.332.678
Terminals – Part B	6.751.590.364	5.626.325
Depot - Part A	4.702.614.685	3.918.846
Depot – Part B	3.705.090.358	3.087.575
Road Construction - Part A	33.152.709.747	27.627.258
Road Construction - Part B	29.973.682.785	24.978.069
RAP - Part A	15.329.591.256	12.774.659
RAP – Part B	13.859.630.451	11.549.692
Fare Collection	3.702.804.000	3.085.670
Operational Control	271.080.000	225.900
TOTAL AMOUNT	129.876.688.512	108.230.574

NOTE: RAP – Resettlement Costs

2.4

Project Operational Characteristics

DART operational design and bus trip offer was designed with use of transport demand modeling software EMME2, based on the demand trip matrix defined for the AM peak period. Demand was assigned to existing road trunk and feeder road network through lowest generalized transport cost election criteria (considering both cost and travel time).

Based on the demand trip matrix, a standard vehicle was selected for trunk and feeder system operation and necessary fleets were dimensioned (Section 2.4.1). Similarly, trunk and feeder services were designed and routed, including definition of trunk services offer plan for local and express services, as well as feeder service routes, frequencies and production information (Section 2.4.2).

2.4.1

Standard Vehicle and Fleet Dimensioning

Bus fleet dimensioning for each trunk and feeder service was based on morning peak hour frequencies and on approximately 430.000 passenger daily demand for the entire system.

Initially, the following hypotheses were assumed for selection of the standard vehicle and dimensioning of the necessary fleet:

- All trunk services will be operated with buses of a maximum capacity of 160 passengers.
- Fleet reserve was fixed at 5% of required fleet at peak hour.
- Time spent at signalized intersections: 15 seconds.
- Time spent at each station: 25 seconds (including 3 seconds for breaking, 7 seconds for acceleration and 15 seconds for door opening and closing and passenger boarding and alighting).
- Cruise speed: 60 km/h
- Operational speed: 22 km/h
- Time lost at terminals, including bus return and driver break: 1 min.

Subsequently, based on comparison of bus types currently available in the market, associated investment and operational costs, it was established that the standard vehicle for trunk services shall be an articulated bus with maximum capacity of 140 passengers, and that the feeder buses shall have capacity for 50 passengers. However, some modifications in feeder vehicle capacity might be considered to increase operational effectiveness, especially for heavy loaded routes on highly demanded feeder corridors and for low demand routes for which smaller vehicles could operate.

Under these conditions, the fleet necessary for operation of DART's Phase I will be composed of:

- 142 articulated buses with a 8 bus reserve fleet (150 buses)
- 221 feeder buses with a 12 bus reserve fleet (233 buses)

Based on this fleet, the following operational conditions will result:

- On average, on a regular weekday with standard operation, the trunk buses will run 3,181 km in the peak hour (44,532 km per day) with a 12.3 passenger kilometer index (PKI).
- On average, on a regular weekday with standard operation, the feeder buses will run 3,658 km in the peak hour (51,211 km per day) with a 7.2 passenger kilometer index (PKI).
- Trunk feeder services will be running at frequencies from 27 buses per hour at the peak

hour, to 10 buses per hour at off-peak hours.

- Feeder route frequencies will vary from 53 to 8 buses per hour at the peak hour period.
- Trunk vehicles will have an average speed of 22 km/h.
- Feeder vehicles will have an average but not certain speed of 17 km/h. (this uncertainty is due to unknown road conditions and/or congestion present along the itinerary).

Articulated bus and feeder bus illustrations are included in **Annex 4**.

2.4.2

Trunk and Feeder Service Design

In order to reach an optimum load factor in trunk services, different types of services must be set up in accordance with DART travelers needs and preferences. The service design is then focused on demand by zones, searching for the highest occupation index along the route, service optimization through minimizing number of stops and hence increasing the system's commercial speeds.

The physical design proposed for the DART system includes overtaking lanes featured at stations. This makes express services possible and expands the system's transportation capacity. Consequently, services will be of two types:

- Local services: stops at every single station along its path.
- Express services: stops only at predetermined stations according to origin and destination concentration criteria. This will increase operational speeds.

All services have been designed based on a maximum frequency on AM peak hour of 40 buses/hour (1.5 minute headway) and a 10 buses/hour minimum frequency (6 minutes headway). Whenever running services have demand levels outside the limits, an operational revision will be performed to update the plan and service programming. Seven (7) trunk services have been considered, including 2 express services and 5 local services. Proposed services also include 15 feeder routes serving three main terminals and 6 integration stations along the corridors.

Trunk Service Route Selection

With 5 terminals, there are 10 possible different combinations or routes from one terminal to the other ($5 \times 4 / 2$). Trunk services from Kariakoo to Kivukoni and Kimara to Ubungu would be too short to implement so they were not included in the analysis. Only 8 alternatives were considered useful for evaluation.

The simulation analyzed these alternatives through different service combinations. Occupancy levels and load factors indicated that more than five different lines operating simultaneously would be too much for the system's requirements.

Table 2.4.2.a
Trunk Service Alternatives Evaluated

O\D	Ubungo	Morocco	Kariakoo	Kivukoni
Kimara	N	x	x	x
Ubungo		x	x	x
Morocco			x	x
Kariakoo				N
X	Potentially useful			
N	Not enough demand for a special line			

The process concluded on headway adjustment according to the demand; users might prefer taking other lines and make transfers to other services. This can make a line vanish within the operational plan. Careful analysis of demand conditions for the different combinations resulted in seven lines, as follows:

Table 2.4.2.b
Selected DART Trunk Services

Code	Description	Type of Service
DR001E	Ubungo - Kariakoo	All Stops
DR001W	Kariakoo - Ubungo	All Stops
DR002E	Kimara Kariakoo	Express Stops
DR002W	Kariakoo - Kimara	Express Stops
DR003E	Kimara - Kivukoni	All Stops
DR003W	Kivukoni - Kimara	All Stops
DR004E	Morocco - Kariakoo	All Stops
DR004W	Kariakoo - Morocco	All Stops
DR005E	Ubungo - Morocco	All Stops
DR005W	Morocco - Ubungo	All Stops
DR006E	Morocco - Kivukoni	All Stops
DR006W	Kivukoni - Morocco	All Stops
DR007E	Ubungo - Kivukoni	Express Stops
DR007W	Kivukoni - Ubungo	Express Stops

These lines service major starting points from Kimara/Ubungo and Morocco to main destinations Kariakoo and Kivukoni (CBD), so only 8.3% of DART riders need to transfer within the corridor.

Figure 2.4.2.a shows the routes of the seven selected trunk services.

Figure 2.4.2.a
Trunk Services

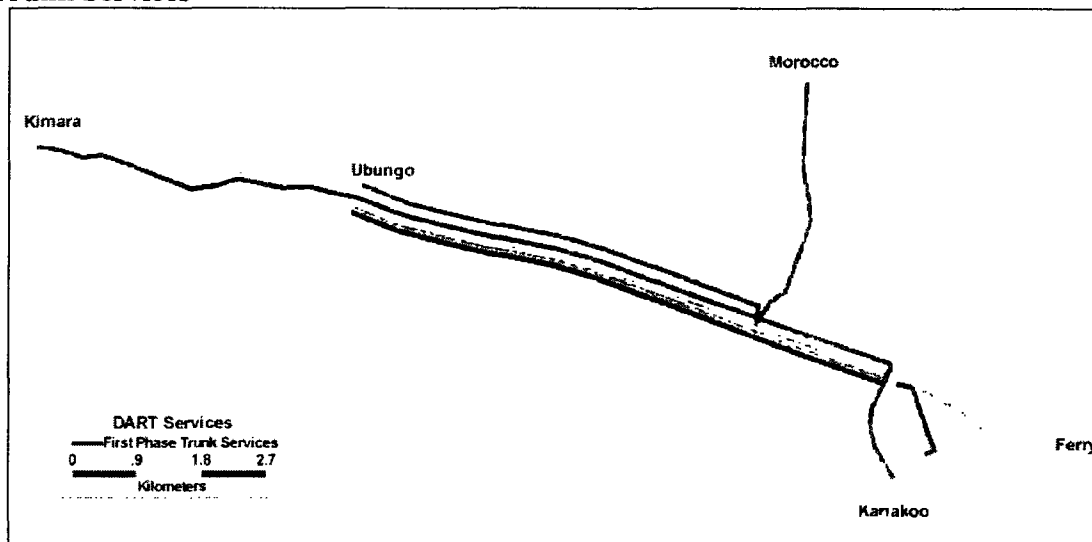

Feeder Routes Selection

Selection of feeder routes considered the following coverage criteria:

- Coverage to areas that, as a consequence of public transport reorganization, would become unattended or inaccessible by means other than taxis or non motorized vehicles.
- Coverage to areas where currently there is inadequate public transport and where new passenger flows could be attracted.
- Extension to areas where short routes would yield high transport demand (over 1,000 pax/hr).
- Greatest coverage the system can support through efficient and flexible routes

Application of these criteria resulted in the following feeder routes and corresponding terminals, stations and coverage areas:

- 1 at Kimara Terminal with coverage along Morogoro Road up to Mbezi surrounding area (Mbezi ward)
- 2 at Ubungo Terminal offering coverage to the university area (Chuo Kikuu subward) and along Sam Nujoma Road up to Mwenge daladala terminal.
- 2 at Shekilango Station going north along Shekilango Road into Sinza A, B, C, D.
- 1 at Urafiki Mahakama Station with access to Mabibo area.
- 1 at Usalama Station which will run along Tandale Uzuri Road offering coverage to

Makumbusho, Tandale, Manzese and Sinza areas.

- 1 at Mwinyijuma Station connecting Mwananyamala and Makumbusho areas.
- 5 at Morocco Terminal running along Old Bagamoyo Road up to Msasani Mwalimu Nyerere and Kawe area, along Bagamoyo Road until Tegeta village. The other branch will cover Msasani peninsula area, up until Masaki area.
- 1 at Magomeni Mapipa Station with service to Kigogo area.
- 1 at Fire Station connecting passengers to Muhimbili Hospital.

Figure 2.4.2.b shows the distribution of proposed feeder routes and their respective areas of coverage.

Figure 2.4.2.b
Feeder System Coverage

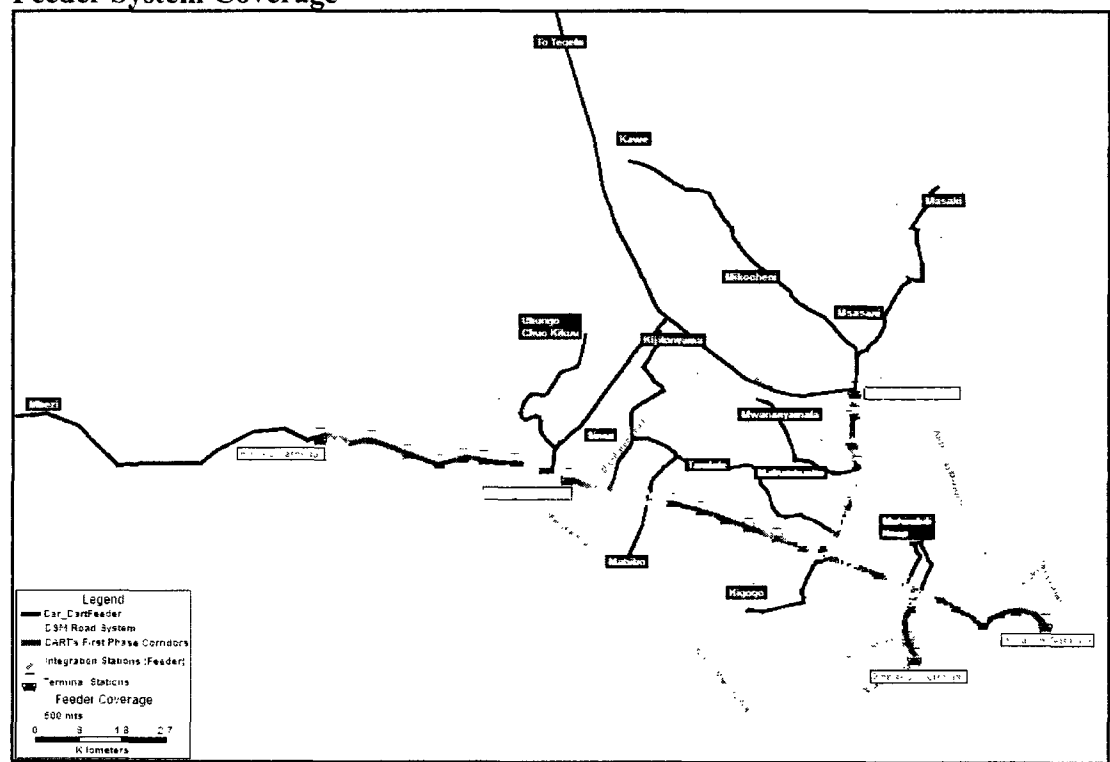

2.4.3

Operational Control Equipment

Operational control equipment necessary for operation of DART Phase I shall include fare collection and control as well as communications equipment and camera surveillance of all key facilities. This will enable operators at the Control Center to detect scheduling or other problems and adjust operations accordingly, as well as to record all system operations as demanded by concession contract reporting requirements.

Main operational control equipment to be installed will include:

Stations and Terminals

Stations and terminals share collection equipments for fare control. This is more cost effective and integrates the system. Closed circuit surveillance cameras as well as display panels will provide real time information. These features require a high investment cost which is usually assumed by the BRT management/executive agency or the fare collector operator. For DART's first phase this monitoring tools might not be appropriate considering the low budget and public investment restrictions.

Control Center

The control center needs to be linked to the fare collection system to get information about entrances and exits from the stations and terminals. Control center needs a building that can be in one of the terminals. It's estimated area is 100 m² with a cost of 80 thousand USD.

Surveillance System

The surveillance system should be part of the fare collection investment and be shared with the operations control.

Communications Resources:

The operational control will be based on GPS and radio communication technology.

Hardware

Main hardware required for DART's first phase control center consists basically of computers and printers.

2.4.4 Project Staffing

As described in Section 2.4.1, operation of DART Phase I will involve 142 trunk buses (plus 8 on a stand-by basis) and 221 feeder micro-buses (with an additional 12 as reserve). Standard operations will run from 5 am till midnight, requiring 3 shifts. Thus, considering holidays, sick leave and necessary stand-by drivers, it is estimated that each vehicle will generate 3.4 jobs. Based on this, the total number of drivers necessary to operate DART Phase I will be approximately 1,235.

Further to the drivers, DART Phase I operation will employ approximately 364 additional persons, according to the following breakdown:

- 198 fare collectors at bus stations and feeder stations
- 30 operational and administrative staff at terminals
- 16 fleet mechanics
- 40 facility cleaning and maintenance
- 28 security guards
- 12 management and administrative
- 40 miscellaneous

Based on the above, it is estimated that DART Phase I operation will generate a total of approximately 1,600 jobs.

2.5 Public Transportation Reorganization

The institutional reorganization of public transportation in the city of DSM is, after the implementation of DART system itself, the second most important task to execute by city officials.

The reorganization of existing daladala routes becomes an issue as a result of the implementation of DART's first phase corridors along Morogoro and Kawawa Roads. This reorganization will help reduce transport externalities of congestion and pollution (atmospheric and noise). It also initiates the renovation of Dar Es Saalam's public urban transportation policy.

Within the city and up to the last inventory of daladala routes done in May 2005, there were 196 daladala routes in operation along a network of approximately 322 kilometers. DSM counts about 1,200 kilometers of roads (both paved and unpaved). First phase implementation will remove 43 daladala routes operating along Morogoro Road and part of Kawawa Road. The remaining 148 routes will run along 296 kilometers in the rest of the city. Some of these will require rerouting.

Reassignment of existing daladala routes was analyzed during the DART design period and proposals were widely consulted with local and regional authorities. DART operation should not affect normal competition between daladalas in remaining routes. Rerouting will make operation smoother and should pose no conflict in the daily operation of the two systems.

Daladala Routes to be Removed

As explained before, the deletion of routes concerned those within the DART influence area which service the same origin – destination pairs. The analysis focused on those running along the corridors of Phase I design, Morogoro and Kawawa Roads.

The design of DART feeder service carefully considered the coverage offered by daladalas. Elimination of any of their routes within the city was the result of replacement by a feeder route or DART trunk service.

Morogoro Road Route Analysis

DSM has a scarce road network. Morogoro Road gives access and exit to the city to the west and inside Tanzania. The existing transport demand has no other alternative and constitutes captive demand for any new transportation system developed along this road.

In the Jangwani area, along Morogoro Road (between United Nations Road and Kawawa Road) there are 39 daladala routes, 75% (29 routes) are coming from western areas along Morogoro Road and the remaining 25% (10 routes) come from northern parts along Kawawa Road.

The remaining 4 routes come from western areas but exit Morogoro Road towards destinations such as Sinza, Msasani and Mwenge. These routes after running along Morogoro Road take either Sam Nujoma or Shekilango roads but should be included into the reorganization scheme as well.

Analysis concludes that all daladala routes operating along Morogoro Road should be removed in order to guarantee demand estimates for DART.

Figure 2.5.a shows daladala routes to be removed from Morogoro road.

Figure 2.5.a
Daladala Routes to be Removed

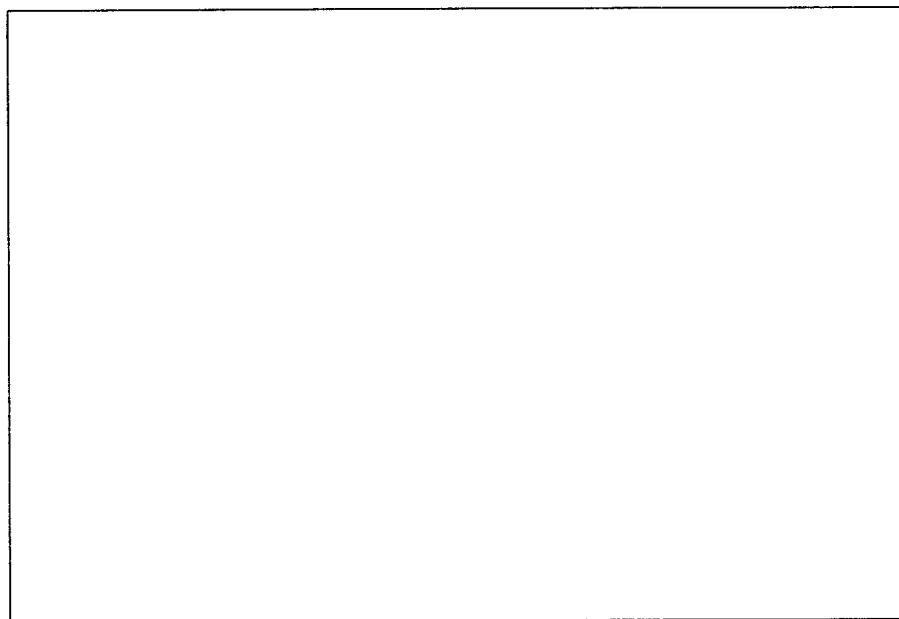

Kawawa Road Route Analysis

Kawawa Road will have both BRT service and some remaining daladala routes. This is because some trips generated along the Kawawa corridor have their expected destination in the south of the city (Temeke, Tandika, Mbagala, and along Nyerere Road, among others) and will not be served by DART Phase I. Expected destinations had to be attended to ensure a reasonable and rightful service. Lack of roads with adequate characteristics made it impossible to redesign those daladala routes.

All daladala routes that turn east on Morogoro Road and head for the Central Business District (CBD) or the Kariakoo area will be removed from Kawawa Road since these routes will be serviced by DART Phase I.

It is important to keep in mind that along the 3.5 kilometers of DART Kawawa corridor in Phase I, daladala and the proposed DART system will be sharing demand with common origins and destinations. However, public will be encouraged to use the system best serving their destination. Southern destinations should ride on daladala and others take the DART.

Of the existing 30 daladala routes coming southbound from Kawawa Road, 33% (10 routes) turn east on Morogoro, they are to be removed. The remaining 67% (20 routes) stay as they are. **Figure 2.5.b** shows removed and preserved daladala routes along Kawawa Road.

Special attention has been given to the physical design along this stretch (Morocco Terminal to Morogoro Road intersection) to insure a good functional relation between DART stations and daladala bus stops or stands. Guiding criteria has been passenger comfort and architectural design quality.

Figure 2.5.b
Removed and Preserved Daladala Routes along Kawawa Road

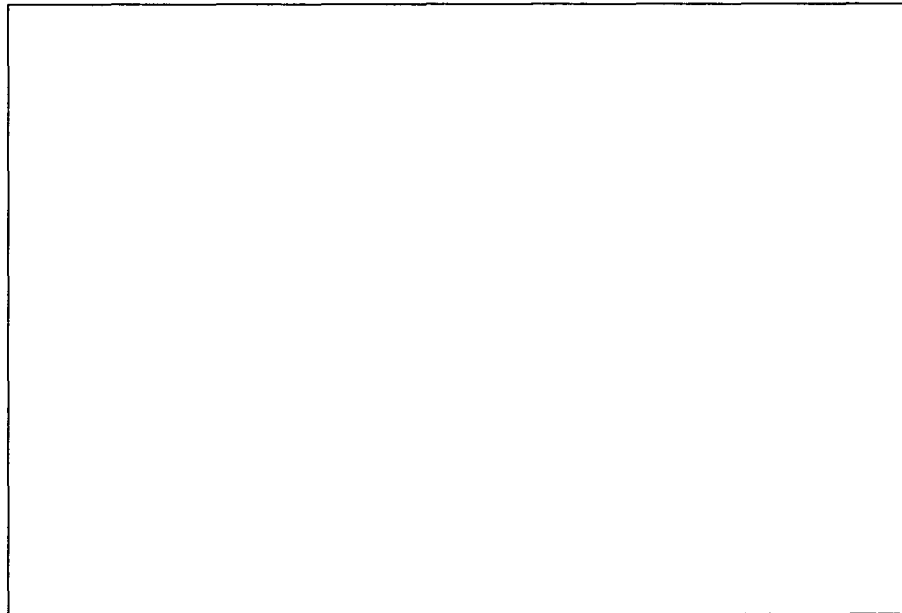

Inventory of Routes to be Removed

Based on the above analysis, a total of 43 daladala routes will be removed, including:

Table 2.5.a
Routes to be Removed

Kariakoo – Bunju	Manzese-Posta	Sinza-Posta
Kariakoo-Kawe	Mbezi-Kariakoo	Kariakoo-Tegeta
Kibamba-Kariakoo	Mbezi-Kivukoni	Ubungo-Kariakoo
Kibamba- Muhimbili	Mbezi-Muhimbili	Ubungo-Kivukoni
Kiluvya-Kariakoo	Mbezi-Posta	Ubungo-Muhimbili
Kimara-Kariakoo	Ubungo-Msasani	Ubungo-Mwananyamala
Kimara-Kivukoni	Mwananyamala-Kariakoo	Ubungo-Posta
Kimara-Muhimbili	Mwananyamala-Kivukoni	Kibamba-Kivukoni
Kimara-Posta	Mwenge-Kariakoo	Kibamba-Manzese
Mabibo-Kariakoo	Mwenge-Kariakoo	Kibamba-Mwenge
Mabibo-Kivukoni	Mwenge-Posta	Kibamba-Posta
Mabibo-Muhimbili	Ubungo-Mwenge	Kimara-Msasani
Mabibo-Posta	Sinza-Kariakoo	Manzese-Muhimbili
Manzese-Kariakoo		Kariakoo-Msasani
		Sinza-Muhimbili
		Vingunguti-Sinza

Figures 2.5.c and 2.5.d illustrate current and future public transportation coverage after DART Phase I implementation. Overlapping explains how the system, though removing routes, is actually improving the network's coverage and extension.

Figure 2.5.c
Current public transportation coverage

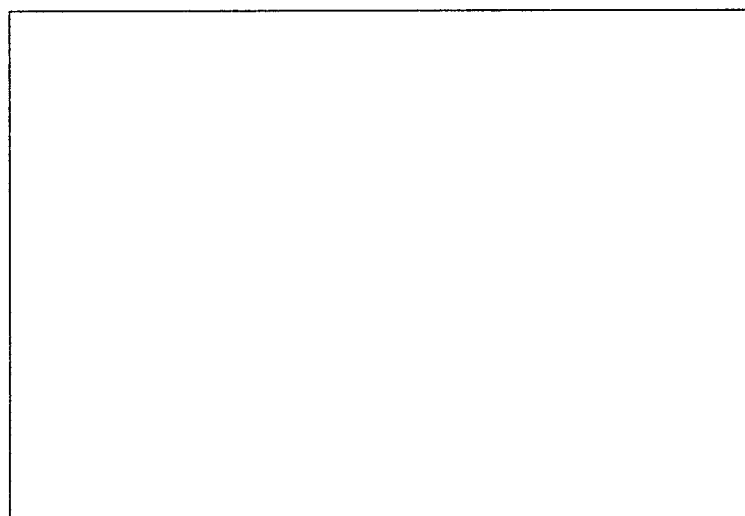
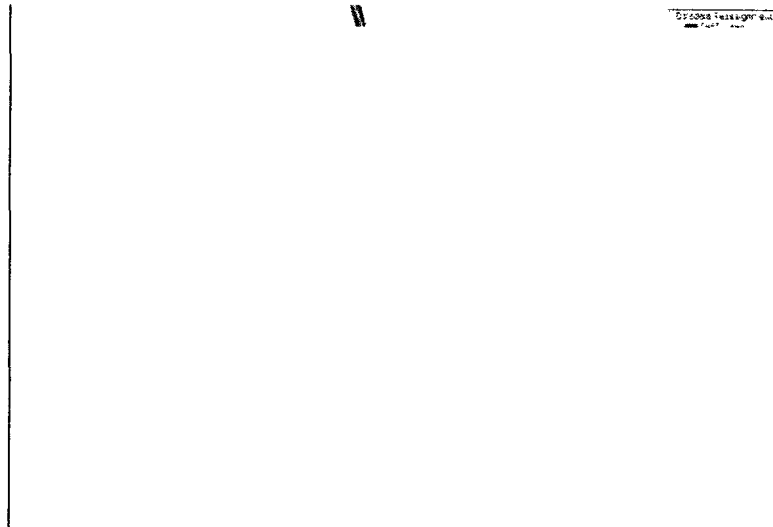

Figure 2.5.c
Future public transportation coverage



Daladala Routes to be Re-routed

As explained above, Morogoro Road represents the main access to DSM city center – Kivukoni and Posta, Muhimbili Hospital and Kariakoo Market area. Daladala routes running on Morogoro Road with these destinations are included in the “to be removed routes list”. This leaves for discussion what to do with the remaining routes that will continue serving these crucial destinations.

Planning focused on identifying operationally efficient alternatives that preserve current accessibility, promotes urban renovation, enhances Central Business District (CBD) and surrounding areas traffic flow, and allows DART implementation to be as hassle-free as possible.

Access patterns were identified to three different areas :

- General CBD daladala flow and Kivukoni Terminal access.
- Muhimbili Hospital access.
- Kariakoo Market, Msimbazi Street daladala flow and Mnazi Mmoja terminal access.

On these three areas the most significant changes will occur with regard to inbound and outbound CBD routes. Proposed daladala re-routing will require prior implementation of general traffic organizational changes, as proposed for the CBD and described in Section 2.6.

General CBD and Kivukoni Terminal daladala re-routing

In the CBD the daladala re-routing considers detour of buses running from Azikiwe Street onwards till Kivukoni, to alternative circulation on roads other than Kivukoni Front, Sokoine Drive and Uhuru Street on the way out of the CBD.

Present daladala routing in the CBD is illustrated in **Figure 2.5.e**. As can be seen, all daladalas access the CBD area from Bibi Titi Road, entering through Maktaba/Azikiwe Street down to Kivukoni Front and, depending on the final destination, proceed to Kivukoni Terminal or outbound CBD taking Sokoine Drive to the southwest destinations.

Outbound CBD routes vary depending on destination outside the city. Destinations on the north take back Maktaba/Azikiwe Street up to Bibi Titi Road, and the ones going west and south continue along Sokoine Drive, take later Uhuru Street or continue on Soloine towards Bandari Road to south destinations (Mtoni, Mbagala, and others).

Proposed inbound CBD re-routing is described as follows:

Daladalas will continue accessing the CBD area through Azikiwe/Maktaba Street. At the intersection with the later and Garden Avenue the daladalas going to Kivukoni Terminal will detour and continue heading northeast to Ocean Road, on which they will proceed towards Kivukoni Terminal. Routes with Posta as a final itinerary will continue their existing flow but instead of reaching Kivukoni Front, they will detour northeast on Sokoine Drive and then left on Pemba Road. This is the end of the CBD inbound route.

Figure 2.5.e
Present daladala routing in the CBD

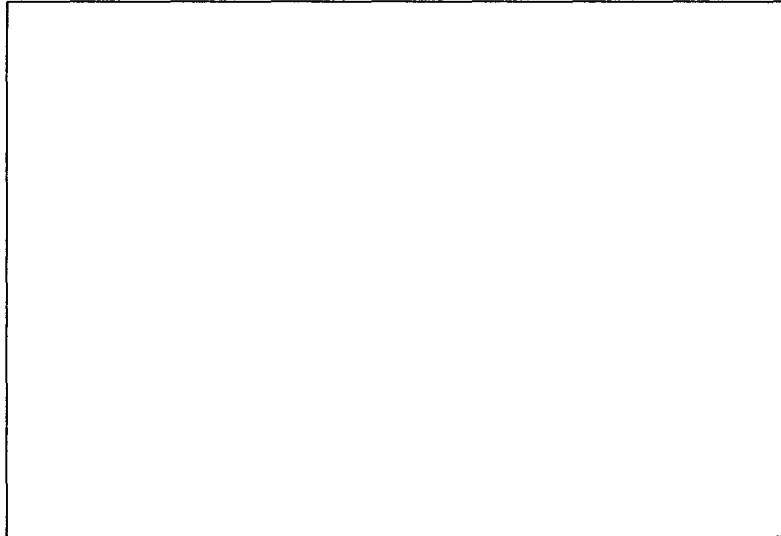

Routes presently accessing CBD from the south which currently run on Uhuru Street (both inbound and outbound) have to change direction in Uhuru Street where Aggrey Street is binary. Circulation will now obey the new direction pattern with Aggrey Street connecting Sokoine Drive with Bibi Titi Road. Uhuru Street will do the same link in the opposite direction. The entrance to Stesheni Terminal will follow the same street direction patterns above mentioned.

Proposed outbound CBD re-routing is even more significant and is described as follows:

Routes coming from Kivukoni will exit also on the Ocean Road in the reverse way until Samora Avenue junction and then along Samora up to the roundabout with Azikiwe/Maktaba Street intersection. They will then proceed towards Bibi Titi Road. This corridor will be the exit channel for the entire daladala fleet serving the CBD.

Once on Bibi Titi Road, the routes will continue either to Uhuru Street or Nyerere Road on their way out of the CBD. A special treatment is being proposed for Uhuru Street and the flow of vehicles coming out of the CBD. The guiding principle is not to allow intersections of more than 2 phases in the operation. The requirement of a right turn on Uhuru Street intersection for routes entering Kariakoo region from Bibi Titi Road will be served by a new intersection to be opened on Mkunguni Street adjacent to Morogoro Road junction. Following this right turn the exiting daladala traffic will continue on Lumumba until reaching Uhuru Street where it will take the usual itineraries.

Routes leaving from Posta, after running on Pemba Road will use Samora Avenue to access Maktaba/Azikiwe Street and proceed with the outbound path explained for Kivukoni routes.

Figure 2.5.f shows proposed inbound and outbound CBD daladala routes.

Figure 2.5.f.

Proposed Inbound and Outbound CBD Daladala Routes

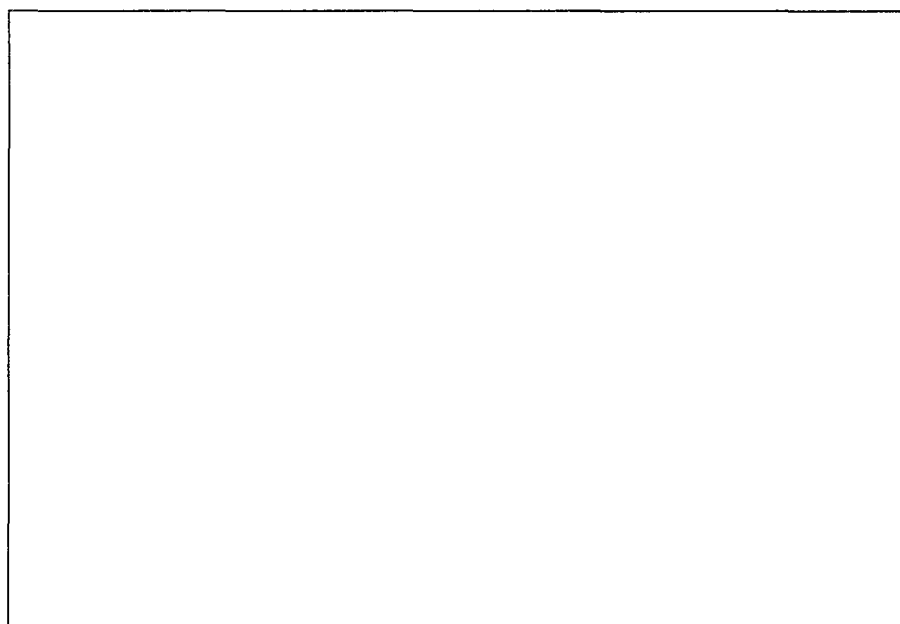

Annex 5 shows current and proposed routes for all daladala services to be re-routed.

2.6

Central Business District (CBD) Traffic Reorganization

Implementation of DART Phase I will convert Morogoro Street on a bus only street. This implies a reduction of available space for general traffic and requires re-designing daladala routes as described in Section 2.5. A major design challenge for the BRT system is, then, defining a new traffic flow concept for CBD streets.

The Consultant's experience on similar CBD cases recommends using as much as possible one way streets, basically for two reasons:

- **Capacity:** On intersections, one way streets reduce conflicts. For example, on a simple crossing of two double way streets there are 16 possible movements and dozens of possible conflicts between these movements. On a crossing of two one way streets there is just one possible conflict. On signalized intersections capacity may increase more than 100%.
- **Safety:** Pedestrians when traversing a one way street need to look just to one side, and on a crossing a maximum of two flows must be observed. Dar Es Salaam's CBD seems an ideal place to use one way streets as a general rule because there are a lot of narrow roads very close to each other.

Sokoine Drive and Kivukoni Front require special attention because they are seriously affected by the new traffic scheme. Other streets directly affected by the project are Uhuru Street, Bibi Titi Road, and Maktaba/Azikiwe Street which currently have a "loop" like operation, in particular those used by public transportation to access and leave the CBD area,.

Reorganization of the CBD induced by DART Phase I will include substantial improvement of the waterfront. Here space constraints oblige to integrate non motorized transportation, mass transit and mixed traffic, unavoidably withdrawing daladala routes. Mixed and BRT traffic will share the right-of-way on the ferry-bound direction and no mixed traffic flow will be allowed on the southern direction along the waterfront promenade.

The proposal for CBD traffic reorganization was based on a complete evaluation of future traffic movements that will interact with DART as well as on suggestions received from city and municipal authorities regarding the convenience of using or not certain streets.

The main aspects of the proposal are:

- Bus only traffic along Morogoro Street within CBD.
- Introduction of one way streets within the entire CBD area on major streets.
- New arrangements and flow definitions for Bibi Titi Road intersections given that

this road demarcates the CBD limits.

- The new intersections with Bibi Titi Road supporting the reorganized traffic flow will be at Zanaki Street, Aggrey Street and Lindi Street.
- Kivukoni Front and Sokoine Drive will be one way streets from Morogoro Road to Ferry terminal.
- Direction is reversed in Samora Avenue.
- Zanaki Street becomes a one way street towards the waterfront.
- Lumumba Street road becomes one way from Nkrumah Street to Uhuru Street to simplify both intersections.
- Lumumba Street, Uhuru Street and Nkrumah Street become a small ring road to allow crossing Bibi Titi Road on two phase signalized intersections.

After reviewing roads that could eventually be used for daladala routes with itineraries ending in Kivukoni, and considering the street direction change, a proposal was elaborated detailing functional operation for every daladala route within the CBD (Section 2.5).

Implementation of CBD traffic reorganization should follow a four-staged joint action plan that considers the following sequence:

- Construction of new, and adaptation of existing intersections along Bibi Titi Road.
- Changes in street directions begin by making Morogoro Road pedestrian. This prepares CBD circulation for future construction and DART operation.
- Construction of DART infrastructure along waterfront.
- Once DART starts operation the daladala reorganization as described in Section 2.5 should be implemented, involving both route deletion and rerouting process.

Extensive public disclosure, as well as enforcement measures and education of drivers and public transport users will need to be continuous during the implementation process.

The proposed CBD traffic rearrangement is shown in **Figure 2.6.a.** In order to verify traffic impacts of this proposal, current traffic levels were surveyed and capacity analysis was conducted on all main CBD streets and intersections. Resulting vehicle dispersion through the CBD road network was also modeled and assessed. Some of the main conclusions of traffic dispersion analysis are presented below:

- Zanaki Street, which today does not connect to the SW-NE side of Bibi Titi Road, is proposed as the main alternative to inbound Morogoro traffic volume (60%). It is converted to one way towards the coastline, absorbing also part of (40%) Aggrey Street inbound volume. A right signalized turn will be provided at the intersection with Bibi Titi road.
- Aggrey Street will be an outbound street and will absorb 60% of Morogoro Road outbound volume and well as part of Uhuru Street volume. There is now a non signalized intersection with Bibi Titi Road that will become a simple two phase

intersection.

- Uhuru Street will become only inbound and absorb part of the traffic of Aggrey Street, Morogoro Road and Nkrumah Street.
- Nkrumah Street will be outbound and absorb mainly Uhuru and part of Morogoro traffic volumes.
- Lindi Street will be inbound and will absorb most of Nkrumah Street inbound traffic volume. A right turn signalized crossing from Bibi Titi Road will be installed.
- Total CBD traffic volumes will decrease in both directions as a consequence of partial daladala substitutions by DART Phase I.

The following table presents modeled results for each key CBD intersection comparing present and proposed peak factors. 'Y' stands for highest saturation value on peak period as a percentage of capacity..

Table 2.6.a
Final Saturation Results for Bibi Titi Road Intersections

Intersection	Peak Saturation Factor (Y)	
	Present	Proposed
Ohio St	0.88	0.77
Maktaba St	1.00	0.69
Zanaki St		0.60
Morogoro Rd	0.93	0.53
Aggrey St		0.63
Lindi St		0.42
Uhuru St	0.95	0.43
Nkrumah St	0.89	0.61

In all cases (where the intersection is already signalized and currently in operation) a considerable reduction on saturation levels was observed, thus confirming the effectiveness of the CBD reorganization and street redirection proposal.

For those used to the present traffic configuration it might seem at first counterproductive to remove private vehicles from operation in Morogoro Road. Nevertheless, reorganization of traffic based on DART in the CBD will bring about improvements in flow, connectivity, speed and organization.

Figure 2.6.a
Proposed CBD Traffic Rearrangement

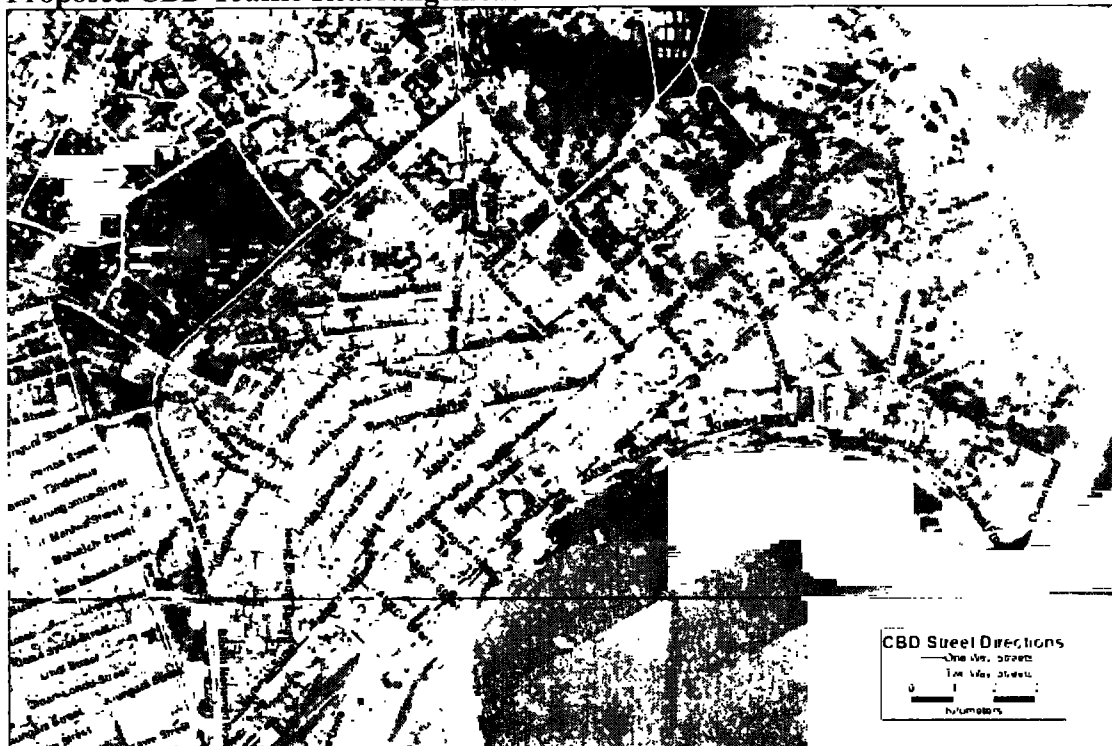

2.7

Project Business Plan

The proposed overall organizational structure for operation of the DART System will include the following main entities:

- DART Agency (DART Agency Implementation Team prior to establishment of the DART Agency) – Will be responsible for overall management of the system, policy-setting, regulation, planning and control of operations and marketing.
- DART Fare Collector – Will be responsible for daily fare collection, maintenance of the physical infrastructure at the bus stations, acquisition and maintenance of equipment used at the station, as well as cleanliness and security at stations.
- DART Bus Operator(s) – Will be responsible for acquisition, operation and maintenance of buses along specified trunk and feeder routes.
- DART Fund Manager – Will be responsible for financial management and reporting, liquidity control and payments to the system operating entities (bus operators, fare collector, DART Agency and the Fund Manager itself).

Once the DART Agency is created and infrastructure development is started, a bidding process will be initiated in order to select the companies that will perform the operational functions specified above.

The DART Agency will then produce an operational schedule for the buses. When bus operations commence, the bus operators must adhere to the schedule provided by the executive agency, and make sure the buses are always in service and in good condition as established in contract.

The Fare Collector will be collecting fares from passengers as per contractual agreements. The Fare Collector will also be required to comply with cash holding limits by ensuring that collected cash is dispatched to the Fund Manager on time. The Fare Collector will oversee smooth passenger movement when boarding and alighting from buses.

The Fund Manager will distribute the income to all system entities, including itself, as per the contractual formulas established by the DART Agency.

Bus Operator(s) for DART Phase I will be responsible for operating both trunk line buses and feeder line buses. They will be responsible for all rolling stock acquisition and bus operating costs. Remuneration of the operators will be based on the following cost mark-up logic:

- For the trunk buses, remuneration will be based on traveled kilometers, therefore including all variable and direct costs directly related to the trunk buses plus a mark-up rate.
- The feeder bus remuneration will be based on the number of transported passengers.

Bus Operators will be required to employ daladala drivers that will lose their jobs as a result of DART Phase I implementation. A minimum requirement in this respect will be included in the bidding conditions.

Furthermore, the bidding conditions will require that Bus Operators establish partnerships with daladala cooperatives / associations representative of the daladala operators to be most affected by the project

The Fare Collector will receive a fixed percentage of total revenue. This will be established during the bidding process. The Fare Collector will be responsible for all fare collection infrastructure cost, including system user card donations.

The DART Agency will be guaranteed the revenue necessary to operate on a positive cash-flow basis. Any agency investments in equipment/software will be made possible through “grants” from the operating system

A contingency fund will be created and will be designed to function as a buffer for the system. It will retain all surplus revenue and may be used for delaying tariff increases or to cover unforeseen expenses.

3.0 Alternative Analysis

3.1 Technological Alternatives

The main technological alternatives regarding urban mass transit are the following:

- Bus Rapid Transit (BRT)
- Elevated Rail
- Light Rail Transit
- Monorail
- Metro Rail (subway or surface)

The ITDP BRT Planning Manual considers that “*the choice of transit technology should be based on a range of considerations, with performance and cost being amongst the most important*”. The manual further points out that for most developing cities, the infrastructure costs will be a pre-eminent decision-making factor. Developing cities often face a borrowing cap which acts as a ceiling to the total amount of borrowing that is possible.

ITDP provides data on comparative costs of alternative mass transit technologies:

“BRT systems are typically in the range of US\$ 500,000 per kilometre to US\$ 15 million per kilometre, with most systems being delivered for under US\$ 5 million per kilometre. By comparison, at-grade trams and light rail transit (LRT) systems appear to be in the range of US\$ 13 million to US\$ 40 million per kilometre. Elevated systems can range from US\$ 40 million per kilometre to US\$ 100 million per kilometre. Finally, underground metro systems seem to range from US\$ 45 million per kilometre to as high as US\$ 320 million per kilometre. The significant size of the various ranges again indicates the local nature of costing. Additionally, the range depends upon the individual features sought within each system (e.g., quality of stations, separation from traffic, etc.)”

The table below provides comparative infrastructure cost data for various systems.

Table 3.1.a
Capital costs for different mass transit systems

City	Type of system	Kilometres of segregated lines (km)	Cost per kilometre (US\$ million / km)
Taipei	Bus rapid transit	57	0.5
Porto Alegre	Bus rapid transit	27	1.0
Quito (Ecovía Line)	Bus rapid transit	10	1.2
Las Vegas (Max)	Bus rapid transit	11.2	1.7
Curitiba	Bus rapid transit	57	2.5
São Paulo	Bus rapid transit	114	3.0
Bogotá (Phase I)	Bus rapid transit	40	5.3
Tunis	Light rail transit	30	13.3
San Diego	Light rail transit	75	17.2
Lyon	Light rail transit	18	18.9
Bordeaux	Light rail transit	23	20.5
Portland	Light rail transit	28	35.2
Los Angeles (Gold Line)	Light rail transit	23	37.8
Kuala Lumpur (PUTRA)	Elevated rail	29	50.0
Bangkok (BTS)	Elevated rail	23.7	72.5
Kuala Lumpur Monorail	Monorail	8.6	38.1
Las Vegas	Monorail	6.4	101.6
Mexico City (Line B)	Metro rail	24	40.9
Madrid (1999 extension)	Metro rail	38	42.8
Beijing Metro	Metro rail	113	62.0
Shanghai Metro	Metro rail	87.2	62.0
Caracas (Line 4)	Metro rail	12	90.3
Bangkok MRTA	Metro rail	20	142.9
Hong Kong subway	Metro rail	82	220.0
London (Jubilee Line ext.)	Metro rail	16	350.0

Source: ITDP

In choosing between alternative mass transit technologies, infrastructure costs per kilometre need to be assessed jointly with the appropriate overall size of the mass transit network to be created. In this regard, ITDP points out:

“One of the most fundamental determinants of system usability to the customer is the extent of the overall network. A few kilometres of high technology will likely not coerce commuters into becoming customers. A limited system of only a few kilometres will mean that most of a person’s essential destinations are not reachable by the system. When systems form a complete network across the expanse of a city, then the ability to function without purchasing a private vehicle is considerably higher.”

The figures below present a graphical way of looking at the trade-off between infrastructure and network length. This figure is based on average costs for metro (US\$ 100 MM/km), LRT (US\$ 20 MM/km), Urban Rail (US\$ 50 MM/km) and BRT (US\$ 5MM/km). As

expected, the lower capital costs of BRT and LRT systems favour the development of a more extensive system at an equal cost.

Figure 3.1.a
Four mass transit system networks at the same investment cost

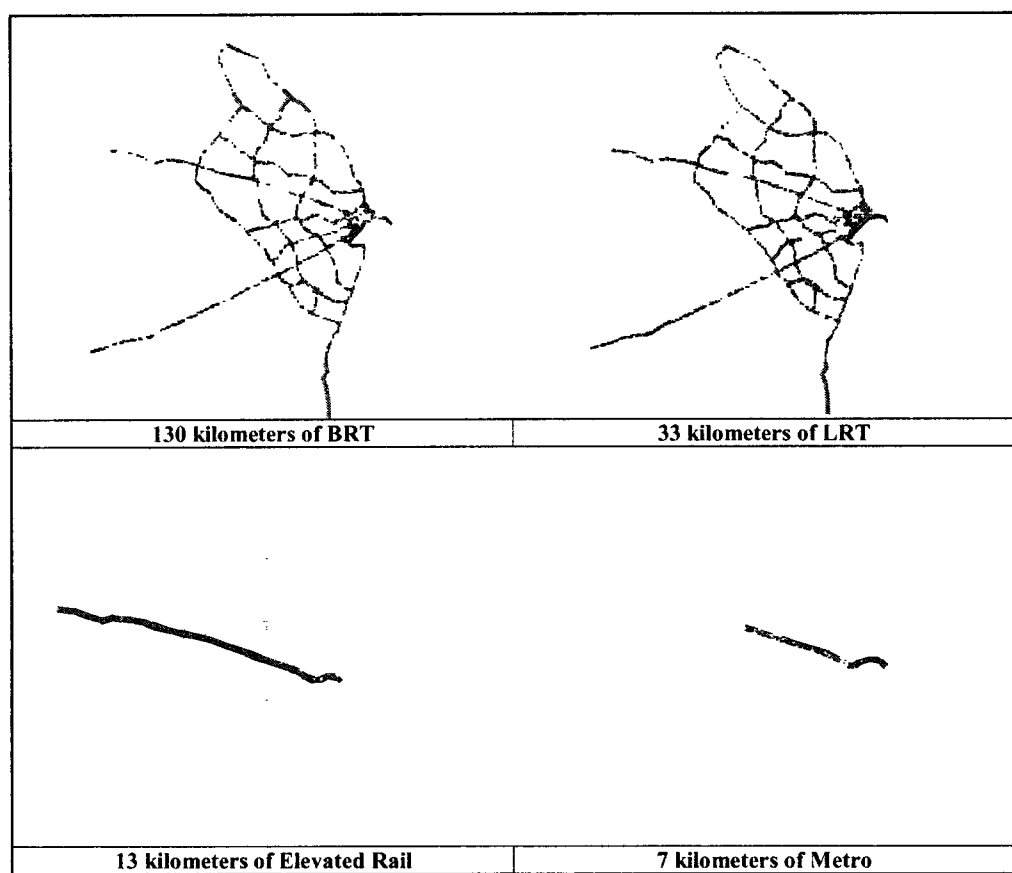

From the user's perspective, a full network serving most major origins and destinations is fundamental to system usability. A system consisting merely of few kilometres or a single corridor makes the system relatively unusable to most customers. Once a person opts for private transport to fulfil some trips, then the convenience and sunk cost of vehicle ownership will typically imply that virtually all trips by public transport are forgone.

A BRT system will likely permit a city to build a network 4 to 50 times more extensive than a rail-based system costing the same amount. Thus, for most developing-nation applications, BRT is capable of providing more value for the same investment.

With respect to performance, the ITDP points out that “*busways and BRT systems have begun to change the traditional view*” regarding bus transportation systems. With the Bogotá TRANSMILENIO BRT system now achieving an actual peak capacity of 42,000 pphpd (passengers per hour per direction), a new capacity paradigm is being created, where BRT systems exceed the capacity which is possible with Light Rail Transit (up to 12,000 pphpd) and begin to compete with Metro Rail Transit. peak and non-peak periods matches the range of cost-effectiveness of the technology. The table below summarizes capacities actually achieved on a variety of different systems currently in operation.

Table 3.1.a
Actual peak capacity for selected mass transit systems

Line	Type	Ridership (passengers / hour / direction)
Hong Kong Subway	Metro	80,000
São Paulo Line 1	Metro	60,000
Mexico City Line B	Metro	39,300
Santiago La Moneda	Metro	36,000
London Victoria Line	Metro	25,000
Buenos Aires Line D	Metro	20,000
Bogotá TransMilenio	BRT	42,000
São Paulo 9 de julho	BRT	34,910
Recife Caxangá	BRT	29,800
Porto Alegre Assis Brasil	BRT	28,000
Belo Horizonte Cristiano Machado	BRT	21,100
Curitiba Eixo Sul	BRT	10,640
Manila MRT-3	Elevated rail	26,000
Bangkok SkyTrain	Elevated rail	22,000
Kuala Lumpur Monorail	Monorail	3,000
Tunis	LRT	13,400

Source: ITDP

However, selection of mass transit technology needs to be based not only on peak capacity, but also on cost-effective range of operational capacity. This second factor determines if the fluctuations between

The figure below, extracted from ITDP’s BRT Manual, compares the range of passenger capacity for each technology measured against the range of capital costs (based on actual and not theoretical data).

Figure 3.1.b
Passenger capacity and capital cost for mass transit options

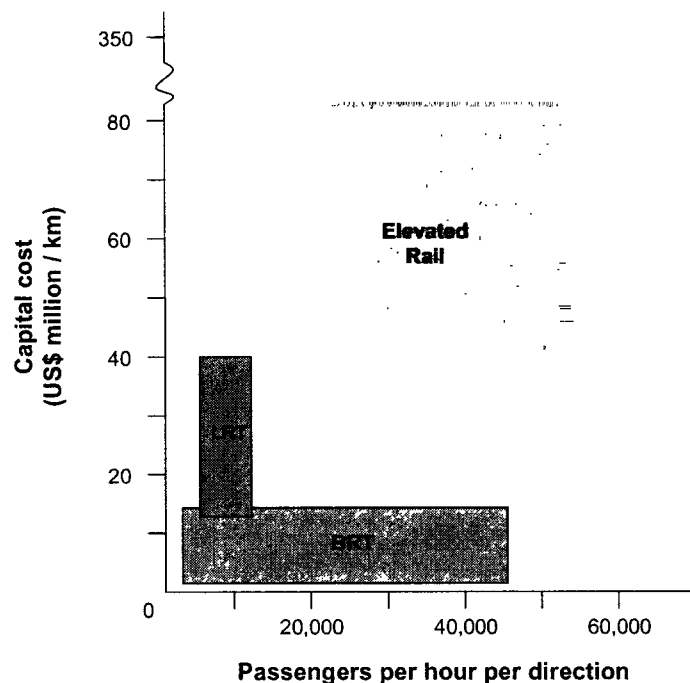

Source: ITDP

The different ranges indicated in the are also revealing with regard to the relative risk and overall flexibility of each mass transit technology option. Ideally, a technology will have a narrow band of possible capital cost levels (y-axis) and a wide band of profitable capacity operations (x-axis). In other words, a system that minimizes costs and maximises the spectrum of profitable operating conditions provides the most cost-effective and flexible solution. The width of the range of capital costs (y-axis) can also be interpreted as an indication of the potential risk and uncertainty involved in implementing a particular type of project.

In this regard, ITDP points out that: “*BRT is increasingly being recognised as a sound technology option for a range of city conditions, and especially for developing-nation cities seeking both high-quality and a low-cost solution. BRT’s ability to operate profitably across a broad range of operating conditions and the relatively low costs of its infrastructure has made it an option worthy of consideration.*”

Based on experiences with BRT projects to date, the conditions which have proven to be most favourable are:

- Passenger demand ranging from 3,000 to 45,000 pphpd;
- Need for average commercial speeds over 20 kph;
- Cities seeking to avoid the need for operational subsidies; and,
- Availability of capital funding in the range of US\$ 1 million to US\$ 7 million per kilometre.

The case of Dar Es Salaam meets all of these conditions, that is to say:

- Passenger demand ranging from 3,000 to 20,000 pphpd along Morogoro corridor;
- Average commercial speeds need to be over 20 kph;
- Dar Es Salaam is seeking to avoid the need for operational subsidies; and,
- The capital funding available is up to US\$ 5 million per kilometre.

3.2

Alignment Alternatives

Since Dar Es Salaam has no consolidated public transportation system, in the long term DART's main objective is to guarantee quality, capacity and efficiency of public transport in the whole city. According to estimations, within 30 years the city will have a population of 7,614,459 inhabitants and 3,066,460 daily trips. The BRT system will have to cover all mobility needs.

The Long Term Transportation Plan aims to improve the road network, offering better and modern mobility conditions and containing BRT corridors along main roads. Road widening and improvement will be one of the main local government's development issues and should also be executed alongside BRT corridors implementation.

The final configuration of the BRT System will constitute a network serving most parts of the city. Definition of which streets are to be used for the BRT has been based primarily on two criteria: demand and availability of space.

The Long Term BRT network will have 137 km of segregated lane corridors, integrated to feeder services and bicycles, in the horizon of 30 years. The system is expected to have 18 terminals, and 288 stations.

It will be implemented in phases, beginning in 2008, and it is estimated that by 2035, 91% of the demand will be served by the BRT System that will be operational on most of the city's main avenues.

Thus, in the context of the final long term configuration of Dar Es Salaam's BRT System, discussion of alternative alignments is a secondary issue, since virtually all main avenues

where BRT implementation is feasible will be used. Nevertheless, alternatives have been discussed to define which corridors will be included in Phase I.

In order to establish implementation priorities, a multiple criteria evaluation process was conducted. This considered:

- Present demand.
- Share of the market to be served.
- Facilities to build.
- Investment cost.
- Expropriation needs.
- Insertion in the city development process.

A team of local experts on Dar Es Salaam urban transport system was consulted to assist with application of the evaluation criteria and respective weights. This process concluded with the definition of implementation phases as follows:

- Phase 1 - (2008) – Morogoro Road, Kawawa Road North, Msimbazi Street, Kivukoni Front – 20.9 km
- Phase 2 - (2012) – Kilwa Road, Kawawa Road South – 19.3 km
- Phase 3 - (2016) – Uhuru Street, Nyerere Road, Bibi Titi Road, Azikiwe Street– 23.6 km
- Phase 4 – (2020) – Bagamoyo Road, Sam Nujoma Road– 16.1 km
- Phase 5 – (2025) – Mandela Road, New Road 1 – 22.8 km
- Phase 6 – (2035) - Old Bagamoyo Road, New Road 2 and New Road 3 – 27.6 km

Figure 3.2.a shows the long term BRT network, indicating each one of the six phases outlined above. Effective implementation of the complete network will depend on available resources and on the city's transportation policy.

Figure 3.2.a
Long term BRT network

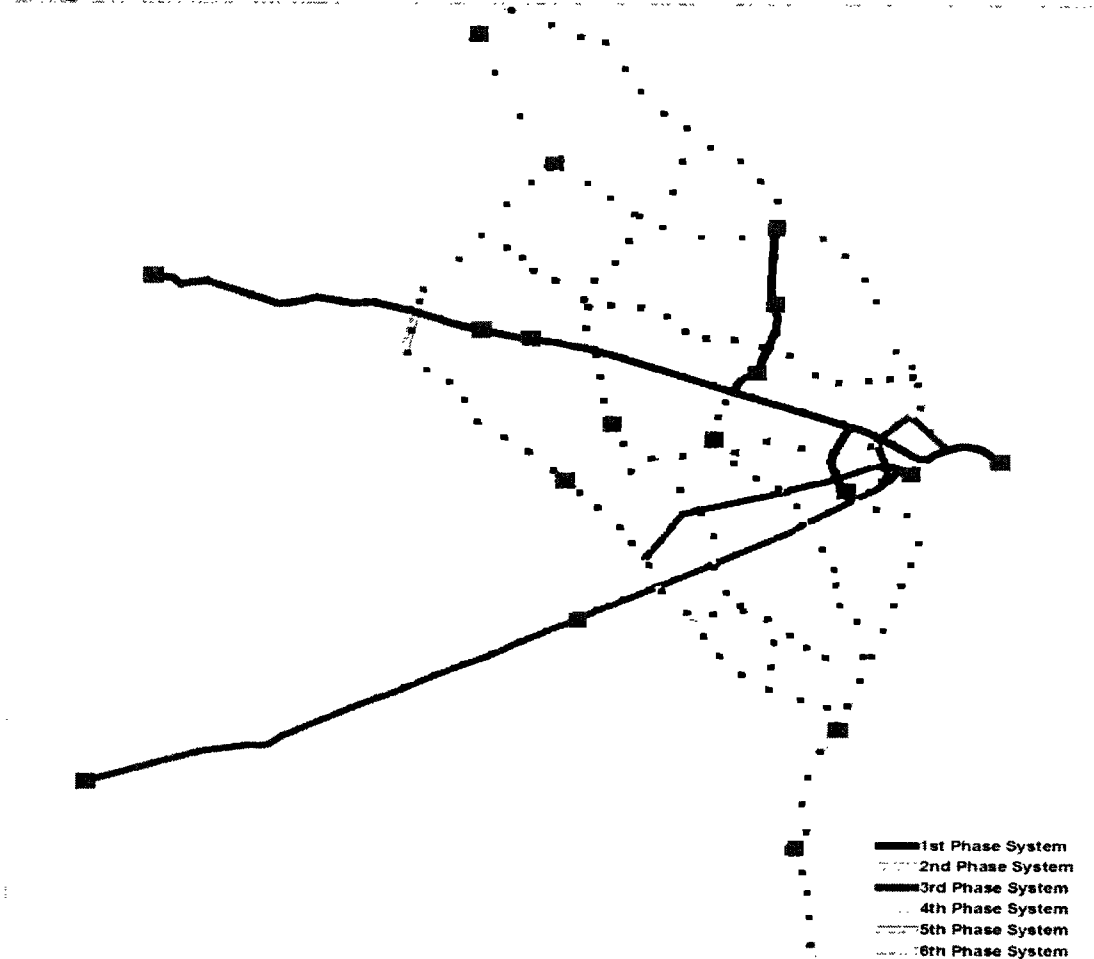

Selection of Morogoro road for Phase I implementation was expected from the start based on present demand. Traffic surveys confirmed the highest demand in the city for this corridor, currently reaching 14,000 passengers per hour.

An evaluation of DART's phased implementation was conducted with Morogoro road as the first corridor, in order to establish which segments of the long term BRT network should be included in Phase I. This evaluation considered the city's transportation behavior and the relations and connections between the selected corridor and surrounding access conditions.

Based on this analysis and the transport demand figures on each one of the major roads and streets where public transportation is available, understanding was gained on the city's

most important corridors connected to Morogoro road. Considering demand volumes from the surveys, rationale for the scope of Phase I was the following:

Morogoro road corridor alone from Kawawa road junction to Msimbazi street (Kariakoo main entrance) has the highest demand with approximately 14,000 pass/hour, but this link has merely 2 km and is not enough to justify by itself investment on a BRT system.

West bound on Morogoro road from the Kawawa road intersection, demand is about 8,000 pax/hour, going down to 4,500 pax/hour at the Nelson Mandela junction. It goes further down to 1,700 pax/hour in the Kimara area. This initially suggested three alternatives with regard to Phase I extension and terminal locations:

- A - One terminal at Ubungo
- B - One terminal at Kimara
- C - Two terminals, one on each location

Alternative A offers a shorter stretch but the connection between the western and eastern parts of Morogoro road involves a vehicle transfer at Ubungo, which implies heavy time penalty for travelers, which at this location represent up to 3,000 pax/hour. The higher the passenger flow, the greater the transfer infrastructure and the area demanded in the design of the terminal. This is expensive and operationally avoidable.

Alternative B offers only one terminal at Kimara. The shortcoming is that Ubungo is an important connection point (Upcountry terminal, Nelson Mandela road intersection, etc.) and passengers won't dispose of adequate space for their transfers. Based on the survey information at this point there are approximately 5,300 DART passengers on transfer at Ubungo and a conventional station will not be sufficient to handle this flow.

In addition, design of the system should consider feeder routes and allow for feeder stations, particularly from this point towards Dar Es Salaam University (Chuo Kikuu) and Mwenge daladala terminal.

Studies were made on all three alternatives and Alternative C was selected based on higher benefits for users in terms of time and cost, better and more comfortable facilities for the system and the users, less need for transfers and more kilometers on the BRT system.

However, in view of the lower demand on this link (with 1,700 pax/hour/direction at Kimara end), the lower present degree of congestion on this corridor segment and budget limitations, it was decided that on Phase I the segment between Ubungo and Kimara will be designed without physical segregation between BRT and mixed traffic lanes, except at station locations.

Along Morogoro road heading towards the CBD, there is a great demand increase from Kawawa road intersection onwards, mainly composed of passengers coming from the northern region towards the city's center and southern part.

To avoid big transfer volumes, such as those that will occur at Ubungo, the 4 km branch along Kawawa road to the north of Morogoro road was included in Phase I. This branch will have a terminal at Bagamoyo road and at the Kawawa road intersection at Morocco.

At the Central Business District there are two main destination points: Kariakoo and Kivukoni. To attend demand and avoid additional transfers, it was decided that the Phase I corridor should reach both destinations. This resulted in inclusion of a corridor branch along Msimbazi street, ending at Kariakoo, as part of Phase I. Kivukoni will be reached by the main trunk corridor, along Morogoro road and waterfront streets.

The basic Phase I configuration thus established includes 5 main origin/destination terminals: Kimara, Ubungo, Kawawa, Kariakoo and Kivukoni.

Consequently, DART's Phase I has been proposed to run primarily along Morogoro road from Kimara region up to Sokoine Drive in the CBD and extending along the waterfront to Kivukoni. Two branches were also included in Phase I: one along Kawawa road from the junction with Morogoro road up to the Morocco region, and the second one along Msimbazi Street, reaching the Kariakoo region.

4.0 Baseline Conditions

4.1 Methodological Framework

Detailed surveys of baseline conditions have been conducted on all areas within which direct and indirect, positive and negative impacts of Phase I of the DART project are likely to be contained. These surveys were planned so as to produce a clear understanding of the "environment" within which the project will be implemented and thus serve as a basis for proper identification of key environmental issues and potential resulting impacts.

The "environment" is here understood in its broadest sense, including its physical components (geology, geomorphology, hydrogeology, climate, etc.), biological components (natural habitats, vegetation and fauna) and socio-economic components (population, quality of life, infrastructure, etc.).

Whereas each environmental or social component is described and analyzed individually, geographical limits of the analysis (i.e. areas of influence) have been standardized to the

extent possible, thus facilitating an integrated comprehension of baseline conditions. Wherever possible, survey data has been mapped and this has involved use of GIS resources.

Scoping Criteria

Survey scoping criteria were previously defined for each environmental and social component, in order to ensure proper focus and selectivity. This process involved thorough discussions with all professionals involved in preparation of the Environmental and Social Assessment (ESIA), and was based on a preliminary discussion of the likelihood and magnitude of the environmental and social risks and probable impacts associated to the project.

Anticipation of likely impacts as early as possible in the project cycle constituted a key aspect of ESIA methodology and allowed the assessment team to maintain focus on critical aspects and to increase the level of detail of survey work when necessary.

The scoping effort also involved extensive consultation with local authorities and other key stakeholders as described in Section 1.5. Several insights into the project's likely risks, as well as guidelines on strategies for mitigation and/or avoidance of resulting impacts, were presented during this consultation process and influenced the ESIA process.

Due to the intensely modified nature of the "environment" likely to be affected by the project, this resulted in very detailed and extensive survey work on socio-economic aspects, particularly with regards to urban structure and affected land-use. Similarly, since public transportation will be the aspect most significantly affected by the project, analysis of current transportation system conditions deserved special emphasis.

Areas of Influence

Baseline studies have been structured according to a staged methodological procedure involving three levels of detail. For each of these levels, specific "areas of influence" were established.

At the broader scale, an "Indirect Area of Influence" (IAA) is defined. This is meant to include all regions where the project's direct and indirect impacts will be contained, including project benefits which, as is usual in infrastructure projects, will be geographically disperse.

The IAA established for this ESIA is the city of Dar Es Salaam as a whole, including the territory of the municipalities of Kinondoni, Ilala and Temeke. Mapping of baseline information relative to the IAA has been presented at 1: 80,000 scale. Sourcing of information is based exclusively on existing studies, statistics and geographical maps and data banks.

With regard to the IAA, it is important to recognize that some geographically diffuse impacts may occur outside its limits. However, these are mostly indirect impacts associated to the project's potential for inducement of increased economic development and stimulation of urban growth, whose intensity becomes progressively lower as distance from the project increases. These impacts are properly discussed in the assessment.

Within the general context of the IAA, more detailed baseline data was collected along the areas nearest DART Phase I alignments. In this case, extensive fieldwork was the most important source of information.

A corridor 300 meters wide on each side of DART's trunk line alignments, widening as necessary to include areas surrounding feeder stations, terminals and bus depots, was generally covered.

It is expected that most of the project's direct environmental and social impacts will be contained within this area, from hereon referred to as the "Direct Area of Influence" (DAI). Geographical data within the DAI has been generally presented at 1: 10,000 scale.

It is worth noting that in the case of socio-economic aspects, width of the DAI has been adapted when necessary to coincide with the limits of wards and sub-wards for which statistical data is available. This procedure resulted in a DAI including the territory of the following wards / sub-wards:

Table
DAI wards / sub-wards

MUNICIPALITY	WARD	SUBWARD
Ilala	Gerezani	Gerezani Magharibi
Ilala	Jangwani	Mnazi Moja
Ilala	Jangwani	Ukombozi
Ilala	Jangwani	Mtambani B
Ilala	Jangwani	Mtambani A
Ilala	Kariakoo	Kariakoo Kaskazini
Ilala	Kariakoo	Kariakoo Magharibi
Ilala	Kisutu	Mtendeni
Ilala	Kisutu	Kisutu
Ilala	Kivukoni	Kivukoni
Ilala	Mchafukoge	Kitumbini
Ilala	Mchikichini	Misheni Kota
Ilala	Upanga Magharibi	Fire
Ilala	Upanga Magharibi	Charambe
Ilala	Upanga Magharibi	Mfaume
Ilala	Upanga Mashariki	Kibasila
Kinondoni	Hanna Nassif	Kisutu
Kinondoni	Hanna Nassif	Hanna Nassif
Kinondoni	Hanna Nassif	Mkunguni

MUNICIPALITY	WARD	SUBWARD
Kinondoni	Kimara	Kimara
Kinondoni	Kinondoni	Kumbukumbu
Kinondoni	Kinondoni	Kinondoni Mjini
Kinondoni	Magomeni	Suna
Kinondoni	Magomeni	Dosi
Kinondoni	Magomeni	Idrisa
Kinondoni	Magomeni	Makuti A
Kinondoni	Makurumula	Kibamba
Kinondoni	Makurumula	Kagera
Kinondoni	Makurumula	Sisi Kwa Sisi
Kinondoni	Manzese	Midizini
Kinondoni	Manzese	Mvuleni
Kinondoni	Manzese	Muungano
Kinondoni	Manzese	Mnazi Mmoja
Kinondoni	Manzese	Kilimani
Kinondoni	Mwananyamala	Bwawani
Kinondoni	Mwananyamala	Kambangwa
Kinondoni	Mwananyamala	Mwinjuma
Kinondoni	Mzimuni	Idrisa
Kinondoni	Mzimuni	Makumbusho
Kinondoni	Ndugumbi	Vigaeni
Kinondoni	Ndugumbi	Makanya
Kinondoni	Ndugumbi	Mikoroshini
Kinondoni	Ndugumbi	Mapakani
Kinondoni	Ubungo	Ubungo Kisiwani
Kinondoni	Ubungo	NHC
Kinondoni	Ubungo	Kibo
Kinondoni	Ubungo	Chuo Kikuu
Kinondoni	Ubungo	Msewe

Figure 4.1.a shows the limits of the DAI as adopted for physical and biological aspects of the baseline survey, as well as for mapping of socio-economic aspects.

Figure 4.1.a
Direct Area of Influence

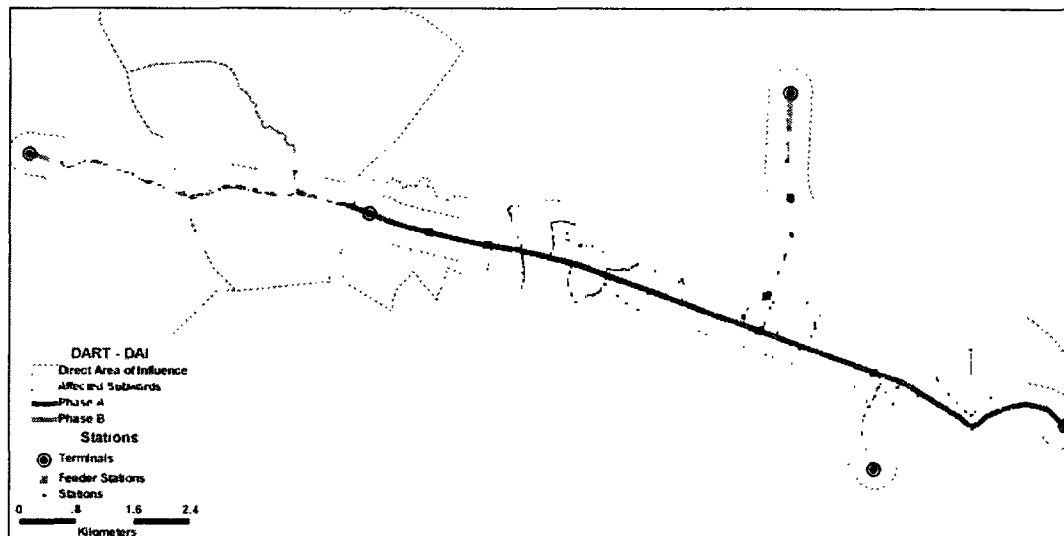

Finally, even more detailed information has been gathered within the perimeter that will suffer direct intervention during DART Phase I construction. This perimeter, heretofore referred to as the “Directly Affected Area” (DAA), includes the right-of-way of the roads where the corridor will be implemented, adjacent areas that will need to be expropriated, abutting property fronts and areas to be directly occupied by feeder stations, terminals and bus depots. Furthermore, the DAA includes construction support facilities (borrow pits, camp sites, other), even though precise location of these is not yet known.

Within the DAA detailed land use maps have been produced at 1: 2,500 scale, as well as information relative to main utilities to be affected and characteristics of vegetation to be cleared. With regard specifically to areas to be expropriated, detailed and extensive property surveys and socio-economic surveys were conducted as part of the process of preparation of Resettlement Action Plans. The main results of those surveys are discussed in this ESIA as necessary to assess the project’s social impacts.

4.2 Indirect Area of Influence (IAA) Baseline Conditions

4.2.1 Physical Environment

4.2.1.1 Climate

Dar Es Salaam is at sea level and lies between latitudes 6°33'49"S and 7°10'49"S and longitudes 39°00'00"E and 39°32'37"E. The climate is typically tropical, with hot weather throughout the year (range about 26°–35°C) and two rainy seasons: short rains in November–December and long rains in March–May.

Tanzania Meteorological Agency (TMA) is the government agency responsible for gathering meteorological data and providing associated services. Within the Dar Es Salaam region, TMA has ten gauging stations as listed in the table below:

Table 4.2.1.1.a
List of Gauging Stations within Dar Es Salaam Region

S/N	STATION NAME	PARAMETER OBSERVED
1	MKJ Nyerere Airport	All meteorological parameters
2	Port Met. Station	All except radiation
3	UDSM	Rainfall and Temperature
4	Msimbazi Mission	Rainfall
5	Dar Chemical lab	Rainfall
6	Ubungo Maji	Rainfall
7	Mtoni Maji	Rainfall
8	Kurasini Polisi	Rainfall
9	Stakishari	Rainfall
10	Wazo Hill	Rainfall

The project's Indirect Area of Influence (IAA) is characterized by a tropical coast climate, and is influenced by South-West monsoons from April to October and North-East monsoons between October and April.

All 10 gauging stations listed above record rainfall data but they do differ in age and hence the range of years of recording is different. Dar Es Salaam has an average annual rainfall of between 1,000 mm to 1,400 mm, which occurs in two seasons as shown in **Figure 4.2.1.1.a**

The short rains with storms of limited duration usually occur in November and December with on average 75 - 100 mm per month. Long rains are between March and May; with a monthly average ranging from 150 – 300 mm. Usually June to October is the dry season. Evaporation rates are on average 2,104 mm per annum (Ministry of Water, 2001).

Figure 4.2.1.1.a

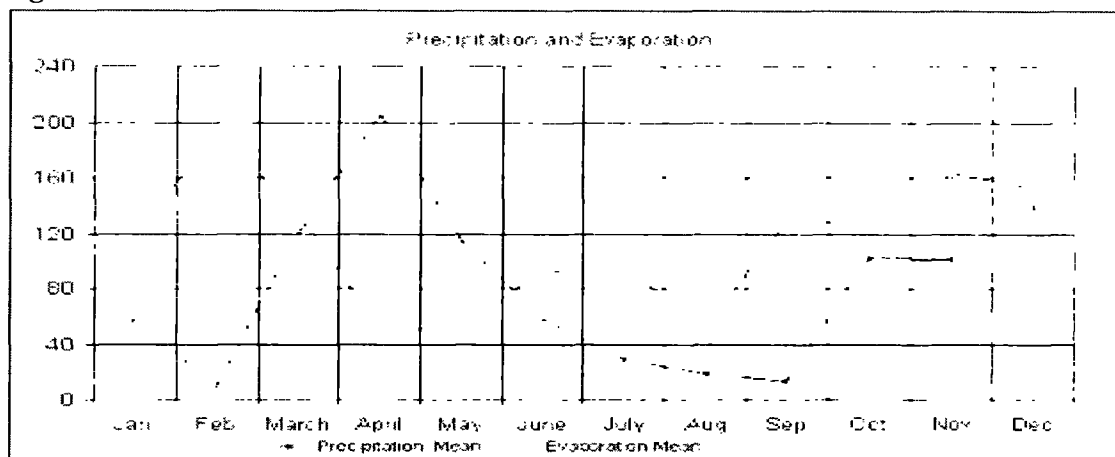

The analysis of rainfall pattern for selected stations shows that maximum and minimum monthly rainfall varies from year to year as summarized in the following table.

Table 4.2.1.1.b
Summary of the Monthly Rainfall Pattern

STATION	YEARS	MAX. RAINFALL		MIN. RAINFALL	
		Range (mm)	Duration (Month)	Range (mm)	Duration (Month)
MJK Nyerere	1996- 2005	297.6- 569.4	March- April	0.6- 95.4	July- Sept.
Msimbazi Mission	1980- 1984	138.8- 411.7	March- May	0.0- 81.5	June- Sept
Dar Chemical Lab	1999- 2003	197.1- 482.4	April	4.0- 94.1	August- Sept
UDSM	1991- 2000	211.2- 600.0	March- May	0.0- 113.6	June- Sept
Mtoni Maji	1972- 1981	150.0- 362.3	March- May & Nov- Jan.	3.0- 109.0	July- Sept

The table above shows that maximum rainfall occurs between March and May (138.8 mm- 600.0 mm) though there can be significant variations between years. Minimum rainfall occurs between July and September (0.0 mm – 113.6 mm).

The city generally experiences a hot and humid climate throughout the year with an average temperature of 29°C. The hottest season is from October to March while it is relatively cool between May and August with temperatures around 25°C.

Within Dar Es Salaam region, only Mwalimu Julius Kambarage (MJK) airport station records mean temperature, and **Figures 4.2.1.1.b** and **4.2.1.1.c** show that station's records for mean minimum and maximum temperatures (°c) over ten years.

Figure 4.2.1.1.b

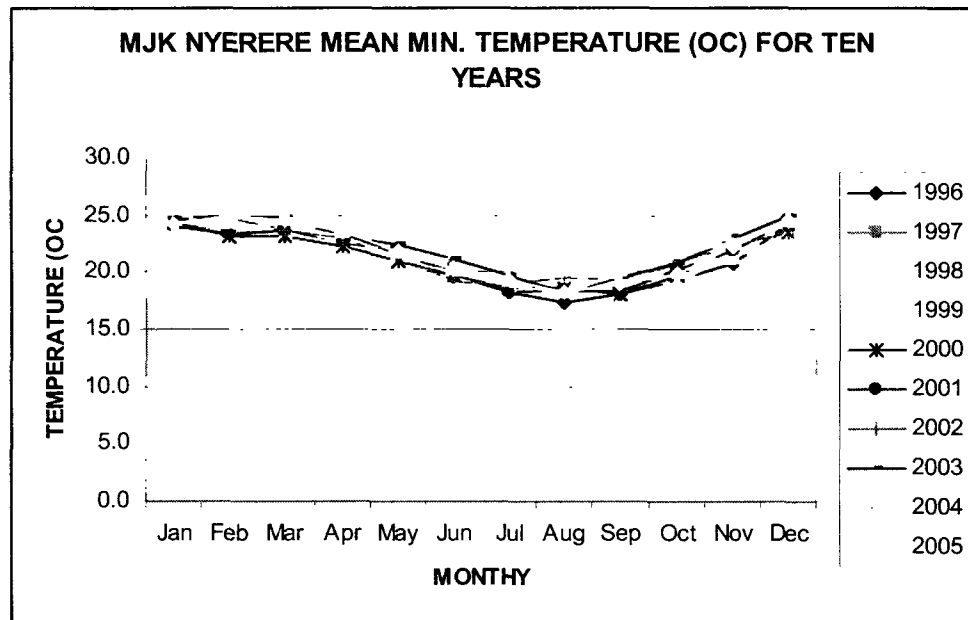
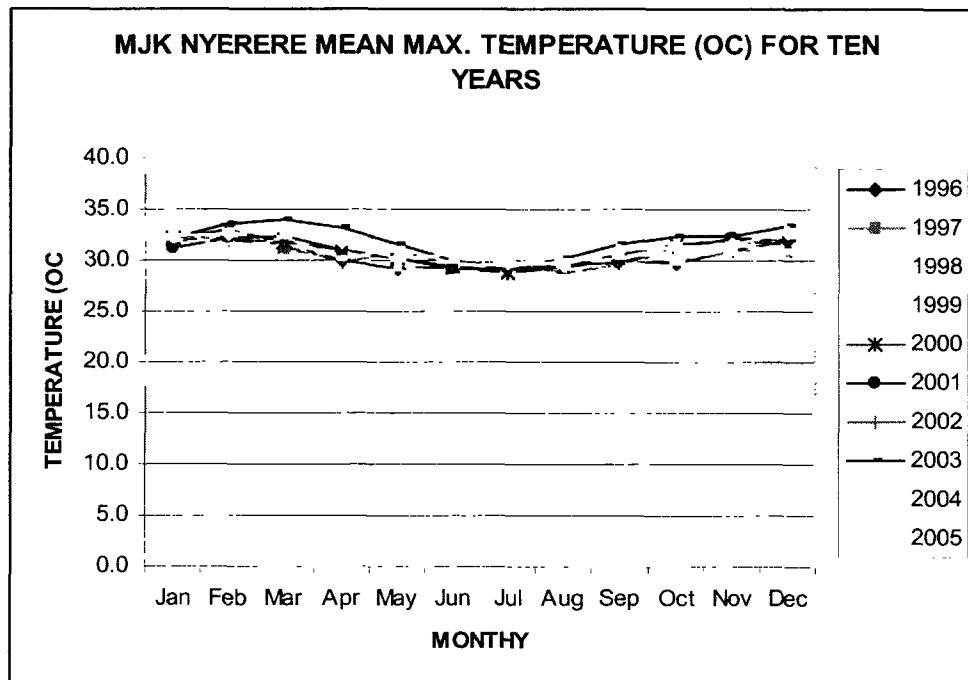

Figure 4.2.1.1.c



Data from **Figures 4.2.1.1.b** and **4.2.1.1.c** show that minimum temperatures range from 17.4 °c to 18.2 °c between June and August, and maximum temperatures range from 33.6 °c to 34.1 °c between February and March.

With regard to relative humidity, standard conditions within the city generally vary between 67% and 96%.

Wind data is available from the Nyerere International Airport station. This indicates that between November and March dominant winds are N, NNE and NE. Between April and September, they are S, SSE, SE and SSW.

Between the months of March and September, wind speeds under 6 knots are the condition that prevails during approximately 40% of the time. Between October and February winds under 6 knots occur approximately 30% of the time. This indicates a condition that is unfavorable to dispersion of air pollutants.

4.2.1.2

Geology and Geomorphology

(a) General

Dar Es Salaam Region is subdivided into two main units known as the Uplands and the Coastal Plain. The Uplands is an uplifted block elevated at 40-200m above sea level with slopes between 5-15% and 15-30% (**Figure 4.2.1.2.a**). The Uplands covers the hills west of Kunduchi and extends up to Pugu and Kisarawe hills. The Uplands also includes the flat lying terrains west of Wazo hill cement factory, Goba, Makongo juu, Changanyikeni, the University of Dar Es Salaam, Ubungo and Kimara. The highest peak is 234m above sea level. The flat lying terrains are a fault block covering predominantly residual soils consisting of clayey sands. West of the flat lying terrains, are the Msanga-Pugu hills with slope angles exceeding 35% and V-shaped Valleys.

The area east of the escarpment forms the Coastal Plain, which slopes gently eastwards to the Indian Ocean. The Coastal Plain is further subdivided into the upper and lower terraces. The terraces are elevated at about 0-70m above sea level and with slope angles between 0-5%. Within the terraces, the creeks are U-shaped. Msimbazi creek is a typical U-shaped creek.

(b) Overburden

The overburden soils within Dar Es Salaam are recent (Quaternary system) consisting of residual soils on the slopes of the Uplands and transported soils in valleys and depressions. The overburden soils vary from gravels to sands, silts and clays. The thickness of the overburden increases in areas with slope angles of less than 15%. These areas lie at the

extreme West and southern parts of Dar es Salaam as well as raised reefs (**Figure 4.2.1.2.a**).

In general, the thickness of overburden soils on slopes with angles less than 15% varies from 2-5m. The thickness of residual soils on the eastern edge of the western Uplands with slope angles greater than 15% is negligible. The average thickness of overlying soils on raised reefs such as Wazo hill is about 5m.

There is a belt of residual saline soils along the low-lying depression of the lower terrace. Similarly, organic soils up to 2m thickness occur within the mangrove areas along the coast.

The overburden on the fringing reef consists of mixtures of residual and transported soils. Overburden thickness up to 5m may occur on fringing reefs at the City Center while at the northern part of Dar Es Salaam the overburden thickness is only about 3m.

Colluvial materials occasionally occur on fault scarps along the eastern scarps of the Uplands and raised reefs. Out-wash sands are the most widespread overburden materials on the upper terrace. Their average thickness is about 0.5m.

The overburden in valleys and creeks consists of alluvial clays, silts, sands and gravels. The average thickness of overburden in creeks is about 7m.

Limestone boulders are common along the coastline of fringing reefs. Windblown materials consisting of silt are occasionally found along the coast.

Beach sands up to 3m thick are situated parallel to the coastline and consist of alternating bands of heavy minerals such as ilmenite, kyanite and rutile interspersed with thick bands of quartz and feldspars.

(c) Bedrock

The bedrock in Dar Es Salaam Region is made of Quaternary and Neogene sandstones and Carbonates. Many different varieties occur within these two groups. Sandstones account for over three quarters of the Dar Es Salaam bedrock. The terrace sandstones of the Quaternary System are more extensive in the central and southern parts of Dar Es Salaam Region (**Figure 4.2.1.2.b**). Sandstones are, however, scarce beyond 5km in the NNW direction of Msimbazi river estuary. All the Quaternary sandstones are completely weathered and they are not differentiated with dense sands and dense clayey sands in all borehole profiles.

Neogene sandstone formations interblended with siltstones and mudstones occupy the upland area South and West of the city center (**Figure 4.2.1.2.b**). There are also calcareous sandstones on the back reef areas of uplands. A 10 km long and 1-3 km wide strip of

siltstones forms part of Kimbiji embayment. This stretch of bedrock is however interspersed with 2-4 m bands of carbonate rocks. On its central western borders, sandstones formations occur that are predominantly kaolinitic and is estimated at more than 30 m thick. The Pugu kaolinitic sandstone comprises three units; massive kaolinitic and cross bedded stones. Medium to coarse grained sandstones form a large part of western highlands. Two similar units also occur in the south eastern part of the region.

(d) Carbonates

Carbonate rocks occur in the form of fringing reefs and raised reefs north of the Dar Es Salaam city center (**Figure 4.2.1.2.b**) in addition to other small outcrops, three main reefs forms tabular slabs on the eastern margins of the western uplands. The three main raised reefs from South to North are the Kunduchi, Wazo and Bongoyo raised reef respectively. The mean thickness of the three reefs is approximately 9 meters. The three reefs consist of limestone units covered by a 10 m calcareous sandstone unit. South of the city center there are also several small occurrences of carbonate rocks fringing the coastline. In comparison to the southern part of the city center, the northern part of the region has few fringing reefs. With the exception of a small occurrence of the Kimbiji raised reef, the southern part of the region lacks raised reefs.

(e) Structure

Geophysical studies revealed that Dar Es Salaam region lies within an area that is traversed by swarms of lineaments and faults. The strike directions of the lineaments tend to form two recognizable sets, NNE and NNW with steep dips towards the NNE and NNW directions respectively. Attempts were made to evaluate the structural configuration of Dar Es Salaam using a combination of airborne, surface and subsurface methods. The evaluations shows that the overburden cover of soils tends to conceal the continuity of faulting within the Dar Es Salaam block. The main creeks trend in the direction of regional and intermediate faulting. The regions have been tentatively divided into three main blocks: Wazo, Dar Es Salaam, and Kimbiji. The Dar Es Salaam block is a down faulted unit while the Kimbiji and Wazo blocks have been more affected by intense vertical movements than the Dar Es Salaam block.

(f) Weathering

Salt weathering is comparatively more significant along the bedrock exposure along the fringing of the coastline due to their proximity to the Indian Ocean. On the other hand, the chemical solution of carbonate rocks is more predominant on the raised reefs, possibly due to change in the base level of erosion.

The weathering process is facilitated by the bare exposure of bedrock and combines the chemical dissolution of carbonates in the rock matrix with the chemical alteration of feldspars into kaolin in the sandstones. According to K.Msindai (1988), the terrace

sandstones are frequently slightly to moderately weathered with grades I to II. Limestones are faintly to highly weathered with grades varying from I-IV. On the other hand, upland areas with residual caps of soil display complete stages of chemical weathering from I-IV. The calcareous sandstones in the west and south of the raised reefs are moderately to highly weathered; grade II-IV. Pugu kaolinitic sandstones weathering grades are from slight to high grades II-IV.

Figure 4.2.1.2.a
Geological Map of Dar es Salaam

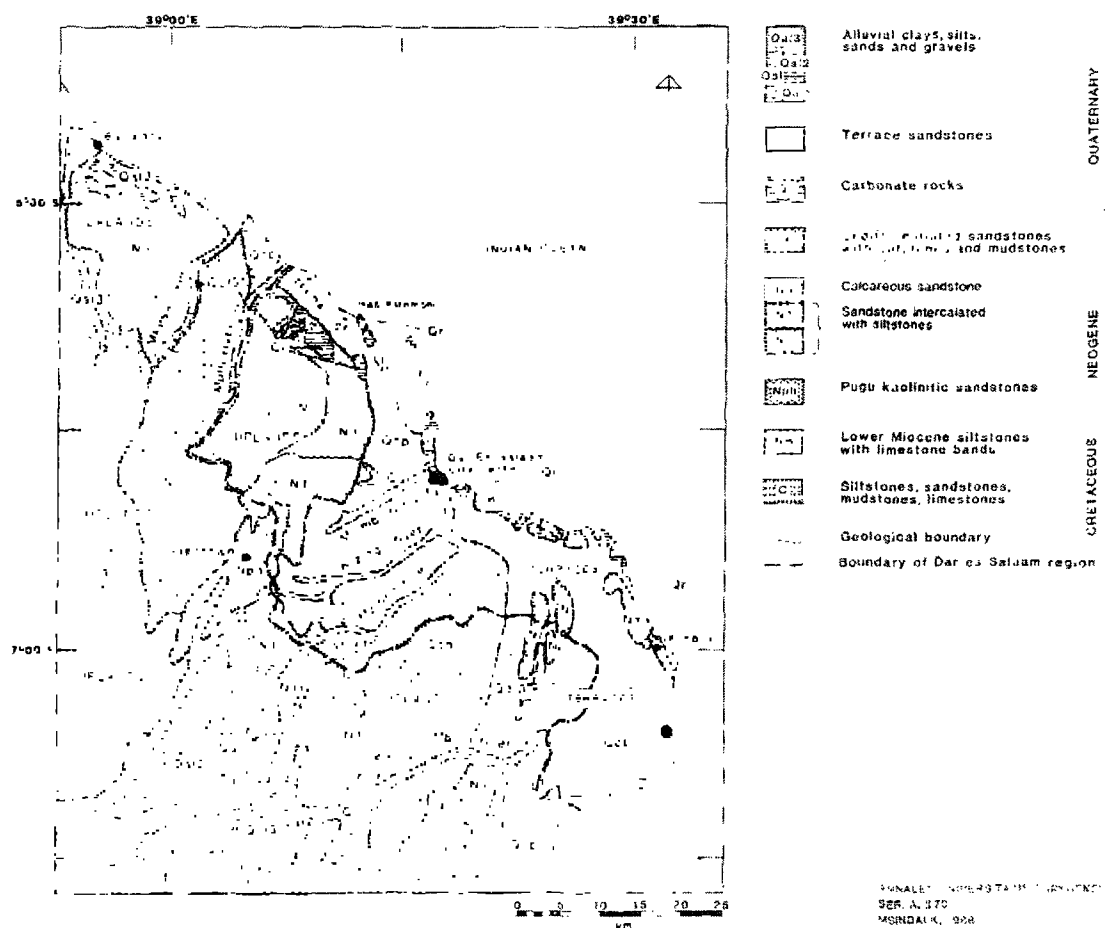

Figure 4.2.1.2.b
Geomorphological Map of Dar es Salaam



4.2.1.3

Hydrogeology

The hydrogeology of Dar Es Salaam is basically controlled by the Neogene geology and geomorphology. Geomorphologically Dar Es Salaam is subdivided into two units: The Uplands and the Coastal Plain. The latter is subdivided further into the upper Tanga Terrace and the lower Mtoni Terrace. These morphologic units run parallel to the present day shoreline.

The Uplands lies over 70 m above sea level. Its eastern boundary is marked by a prominent scarp running North - South through Wazo Hill, University of Dar Es Salaam, Ubungo Kibangu and Pugu Hills. The Plateau extends westwards over the undulating hills of of Kimara, Mbezi, Pugu, Kisarawe to Mlandizi.

The Coastal Plain is the gently, easterly sloping area east of the scarp and lying between 0 - 30 m above sea level.

The Uplands is underlain predominantly by clay-bound sands, clays, silt and occasional loose sands and limestone. Drilling and surface outcrop estimation indicate this unit also known as Morogoro Road Bed to be 200 m thick. These sediments are considered to be of Plio-Miocene age and were of fluvial-deltaic origin. The sparse distribution of limestone and loose sands (which have aquifer properties) and the generally very low permeability of the surrounding clay-bound sands and clays make this area poor in groundwater. Boreholes drilled in this area are between 50 – 120 m deep and those which are successful have yields of 800 – 5,000 lt/hr of mostly saline to occasional fresh water. The salinity is caused by the presence of clays which release the adsorbed ions into the groundwater.

Exceptional areas are along broad and extensive valleys like the Tegeta River valley south of Wazo Hill , Nyakasangwe River valley in Boko/Bunju area and Kilungule in Kimara area. Here 50 m deep boreholes with sandy aquifers have yields of 5,000 – 40,000 lt/hr of fresh water. These valleys are considered to be fluvial channels which were filled in with sands during the high sea level of the Mid-Pleistocene and subsequently became erosional sites as the sea level fell.

The Coastal Plain is underlain by lower Miocene to recent loose sands, clays and coral limestone. The loose sands and coral limestone are the main aquifers in the Coastal Plain. Boreholes drilled in this area have depths ranging from 80 m to 5 m but commonly between 30 – 60 m. The yield varies from 1,000 lt/hr to 45,000 lt/hr depending on the thickness of the aquifer and its permeability. Static water levels decrease from 15 – 0 m seaward. The aquifer quality is controlled by the content of clay in sandy formation and amount of cavities in the limestone.

The Coastal Plain can be sub-divided into two main zones on the basis of groundwater quantity and quality.

Zone 1 Ilala – Temeke Area.

This is an area covering the whole of Ilala and Temeke Districts and the southern central part of Kinondoni District. It has the best aquifer characterized by clean sand and coral limestone. The yields in this area high (up to 30,000 lt/hr) in boreholes up to 70 m deep. The water quality is also good (<2000 μ S/cm). Salinity in this area is caused by sea water intrusion as the shoreline is close.

Zone 2 Kinondoni Area

This is the area covering the northern part of Kinondoni District. This area has saline aquifers with poor yields. The aquifer medium is composed of grayish clayey sands.

The regional ground water pattern in the uplands towards the North has been inferred from the general tilt of the blocks. On the other hand, the direction of local flows is from the uplands towards the sea. Correlation of lithological logs and ground water strikes, as well as the yields of ground water, reveal that unconfined and, to a lesser extent, perched aquifer conditions prevail within the alluvial sands, terrace sandstones and reefs. Movement and storage of ground water in the sandstones and limestones is governed by the amount and connectivity of intergranular material, fractures and porosity.

River bank infiltration into the aquifers is possibly the predominant recharge mechanism. These aquifers are mainly shallow and are the principal sources of water supply of Dar Es Salaam region's rural settlements. Most of the ground water strikes and static water levels within the study region are situated at depths less than 20m below the ground level.

Statistical computations of aquifer parameters show that between drilling depths of 20-80 m, the median yields of ground water are about 2 liters per second, though higher values of up to 5 liters per second have been obtained from some aquifers. Due to high demand of water for domestic as well as industrial use, deeper wells aided by geoelectric surveys have been drilled to depths greater than 80m. The highest yield of 18 liters per second is situated along the upper reaches of Msimbazi creek.

According to the Tanzanian Water Quality Standards, the results of analyses by the Ministry of Water of ground water obtained from aquifers in the sandstones show that the waters are quite often of reasonable chemical quality with 200-500mg/l of total dissolved solids. Nevertheless, it is inferred that the presence of a wide variation of ground water chemistry from fresh to brine can be attributed to the mixing of fresh water with seawater, salt layers or concentration by evaporation.

4.2.1.4

River Systems and Hydrology

The hydrology of the Indirect Area of Influence (IAI) consist of two rivers namely the Msimbazi and Sinza river, the latter being a secondary affluent of the first. **Figure 4.2.1.4.a** illustrates the catchment area of both rivers within the project's location.

Figure 4.2.1.4.a

Msimbazi and Sinza Rivers Catchment Area

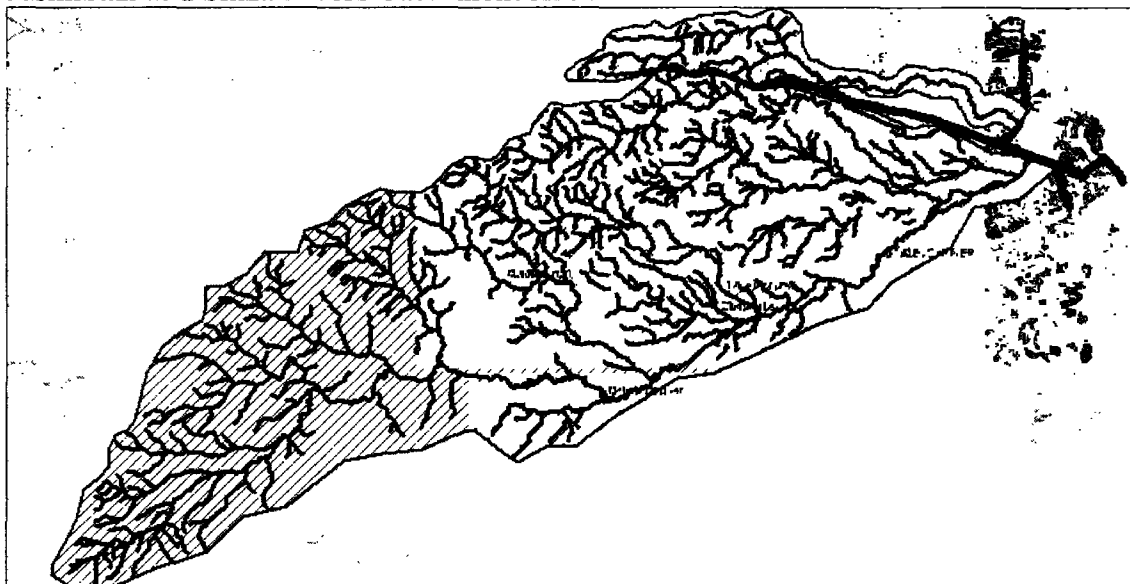

Sinza River crosses the project alignment at Mkwajuni area near Morocco in Kawawa road and Msimbazi river crosses the project at Jangwani valley. From Ubungo to Kimara there are few minor streams crossing the road.

Historically these rivers have not been affected by coastal flooding due to backup of stream flow by the rising tide. These rivers are perennial and meandering; their channel/bed streams are vegetated grasses and there is little silting.

The Msimbazi River originates in the Pugu and Kisarawe hills and passes through thirteen wards of Dar Es Salaam city. It crosses our project road at Jangwani to discharge water into the Indian Ocean. The river system is 38.8 Km long and the catchment area is 194 Km² upstream with the following tributaries: Kinyerezi, Sinza, Ubungo, Zimbiri, Kinyenyere, Luhanga , Mambizi, Kwanguya rivers.

The pattern of the Msimbazi River changes as it flows down stream. Upstream there are many small branches and these branches decreases as it flows down stream. The river has an almost flat channel slope on average of 1 %.

In contrast, the pattern of Sinza River is straight with a small part which meanders with a moderate slope of 1-4%. The rainfall patterns correspond to semi arid zones and some forest vegetation cover occurs along the flood plain some few meters upstream of Kawawa road.

From the topographic map of Tanzania (1988), the drainage pattern of Msimbazi and Sinza Rivers can be classified as a dendritic drainage pattern. This is an indicator that the underlying terrain is composed of homogeneous material. That is, the subsurface geology has a similar resistance to weathering so there is no apparent control over the direction the tributaries take.

Sinza River starts in the Kimara area and passes through various areas such as Kimara, Sinza, Ubungo, Sinza, Manzese, Mwananjamala and Magomeni. It passes across the Magomeni valley near Morocco to discharge its water into the Indian Ocean. It has a length of 16.3 Km upstream of the Magomeni valley with a catchment area of 23.5 Km².

These rivers have lost their functionality due to pollutants emanating from various sources such as dumping of solid waste, industrial effluents, agricultural fertilizers and pollution by sewerage from houses along the nearby rivers. Currently the use of these rivers is restricted to irrigation since they contain coliform bacteria.

Msimbazi and its tributary, the Sinza River pass through most of the unplanned settlement which has led to overcrowding and high population density. The most common sanitation facilities are pit latrines and septic tanks. Given the nature of the terrain and high water table close to the river system. Pits are almost full throughout the year given the economical conditions of the area and the cost of emptying foul water using Cesspit emptiers or Vacuum trucks. Therefore the rivers are used as a receiving end of all sewerage from pits latrines and septic tanks close to the river systems. Only few areas have been connected to the central sewer.

Regarding stream flow data: there is only one gauging station at Ubungo for recording stream flow data; unfortunately this station has not been in use for several years. There is no existing stream flow data for Dar Es Salaam region. Therefore, the only method that can be employed in the design of any hydraulic structure will depend on rainfall data.

The available rainfall data from the ten gauging stations was in the form of water levels. Two stations only will be used in the hydrological analysis since their location is close to our project area. They are the Msimbazi mission and the Ubungo Maji stations. The rainfall data was obtained from Tanzania Meteorological Agency in the form of water level for the period from 1960 to 2004.

The selection of a flood design is primarily concerned with finding a solution with the least overall cost. It needs to balance the cost of a structure designed to undergo a projected flood against the cost of repairs of the structure and the associated length of road, should this flood be exceeded. The effect of a possible road closure on the economy should also be considered. Such consideration usually leads to the adoption of increasing flood return periods for an increasing structure size. In line herewith the following flood return periods are proposed.

Small culverts	10 years
Large culverts	25 years
Bridges	50 years

Since the site has no stream flow data, rainfall runoff models using the TRRL East African Model were employed to estimate peak flows for the Msimbazi river at Morogoro Road and the Sinza river at Kawawa Road. The estimated peak flow with a return period of 50 years for Msimbazi River is 509m³/s and the peak flow for a 50 years return period for the Sinza River is 35m³/s.

It should be noted that urbanization of the catchment areas of these rivers, resulting in increased impermeabilization, may have resulted in peak flows that are higher than those estimated above on the basis of the TRRL East African Model. This may be a more significant issue in the case of the Sinza River whose catchment area upstream of the Kawawa road crossing is virtually all urbanized.

4.2.1.5

Air Quality

Rapid growth has provided the urban economy of Dar Es Salaam with many economic opportunities, and has also led to the rapid deterioration of environmental conditions. The Dar Es Salaam region has not done much in terms of impact assessment, monitoring and controlling of air pollution, though, academic and research institutions have done various studies on air quality in the Dar Es Salaam region.

There are two main sources of air pollution in the city, namely:

- Stationary sources, and
- Mobile sources.

Stationary Sources

Sources under this category includes processing, manufacturing and quarrying industries which generate a reasonable amount of Suspended Particulate Matter (SPM) though their number is not significant therefore their impact on air quality deterioration is not significant.

Mobile Sources

Mobile source especially vehicles (traffic) are the major source of air pollution in the city. They emit pollutants from their exhaust fumes such as lead oxide, carbon dioxide (CO₂), nitrogen dioxide (NO₂), sulphur dioxide (SO₂), carbon monoxide (CO) and suspended particulate matter (SPM). World Health Organization (WHO) standards are currently used to determine the level of pollution since the Tanzania Bureau of Standards (TBS) and the National Environment Management Council (NEMC) have not yet established National Standards on air quality.

The situation of poor air quality caused by traffic is due to:

- Huge number of used vehicles within the city with poor fuel combustion system which leads to production of poisonous gases like SO₂, NO₂, and CO.
- Poor fuel quality, not much emphases on using unleaded fuel,
- Poor town planning, which directs traffic flow in one direction at a time and hence causes traffic congestion,
- Abundance of unpaved streets, which result in significant amounts of SPM, particularly in the dry seasons.

The tendency in Dar Es Salaam is for continued increase in the levels of traffic related air pollution due to rapidly expanding vehicle fleet and increased congestion. On the other hand, gradual verticalization of some parts of the city negatively influences the pattern of pollution dispersion.

Data on current air quality in Dar Es Salaam is available for nitrogen dioxide (NO₂) and sulphur dioxide (SO₂) measured at the following locations:

- Mwenge,
- Ubungo,
- Posta,
- Mnazi Mmoja,
- Kariakoo market,
- Uhuru road,
- Tandika, and
- Buguruni.

Figure 4.2.1.5.a shows NO₂ concentrations in $\mu\text{g}/\text{m}^3$ at those eight locations in 2003. Data is provided for morning, noon and evening hours.

Figure 4.2.1.5.a
NO₂ vehicular emissions in Dar es Salaam

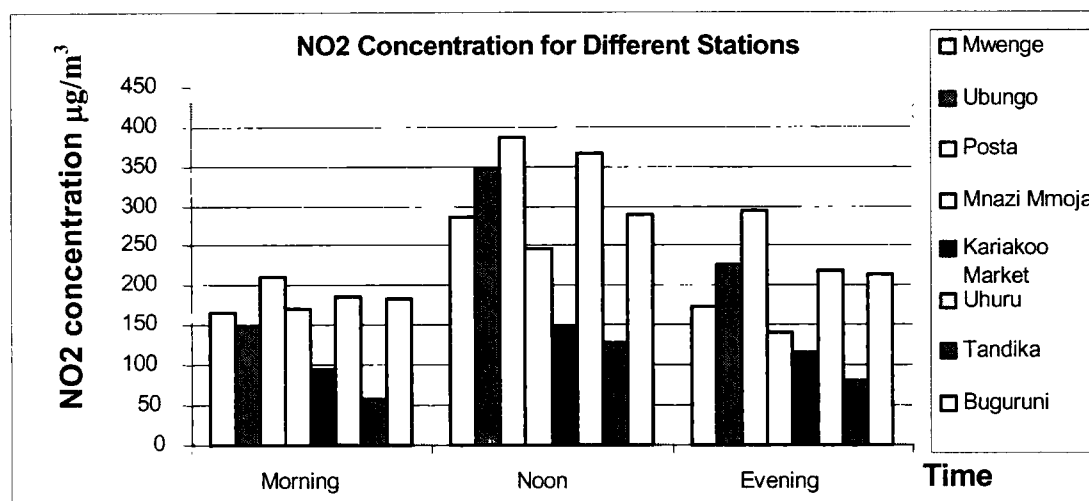

As can be seen, noon is the most critical period of the day and at this time the World Health Organization (WHO) standard of $200 \mu\text{g}/\text{m}^3$ for NO₂ (1 hour average) is exceeded at all locations except at Kariakoo market and at Tandika. The most critical situations occur at Ubungo, Posta and Uhuro, where NO₂ concentrations reach or exceed $300 \mu\text{g}/\text{m}^3$.

During morning hours, concentrations are generally lower and the WHO standard is exceeded only at Posta. In the evening, this standard is exceeded at Ubungo, Posta, Uhuro and Buguruni.

Figure 4.2.1.5.b shows SO₂ concentrations in $\mu\text{g}/\text{m}^3$ at the same eight locations in 2003. As can be seen, daily variations show a similar pattern to that observed with regard to NO₂. In this case, however, measured concentrations show an even more critical situation when compared to the WHO standard of $350 \mu\text{g}/\text{m}^3$ (1 hour average).

Further studies on air quality in Dar Es Salaam showed that hourly average sulphur dioxide concentration ranges from 127 to $1,385 \mu\text{g}/\text{m}^3$. The measured values of sulphur dioxide were above the recommended WHO guidelines with an hourly objective value of $350 \mu\text{g}/\text{m}^3$ at 87% of the sampling sites. The hourly average nitrogen dioxide concentration ranged from 18 to $53 \mu\text{g}/\text{m}^3$. The maximum hourly nitrogen dioxide concentration at $53 \mu\text{g}/\text{m}^3$ was below the WHO guideline value of $200 \mu\text{g}/\text{m}^3$. The hourly average suspended particulate matter (SPM) ranged from 98 to $1,161 \mu\text{g}/\text{m}^3$, exceeding the recommended value of $230 \mu\text{g}/\text{m}^3$ by WHO at 87% of the sampling sites. The hourly average lead

concentration was found to range from 0.60 to 25.6 $\mu\text{g}/\text{m}^3$, exceeding again the WHO guideline value of 1.5 $\mu\text{g}/\text{m}^3$ at 83% of the sampling sites. (Msafiri m. Jackson, 2003).

Figure 4.2.1.5.b
SO₂ concentrations

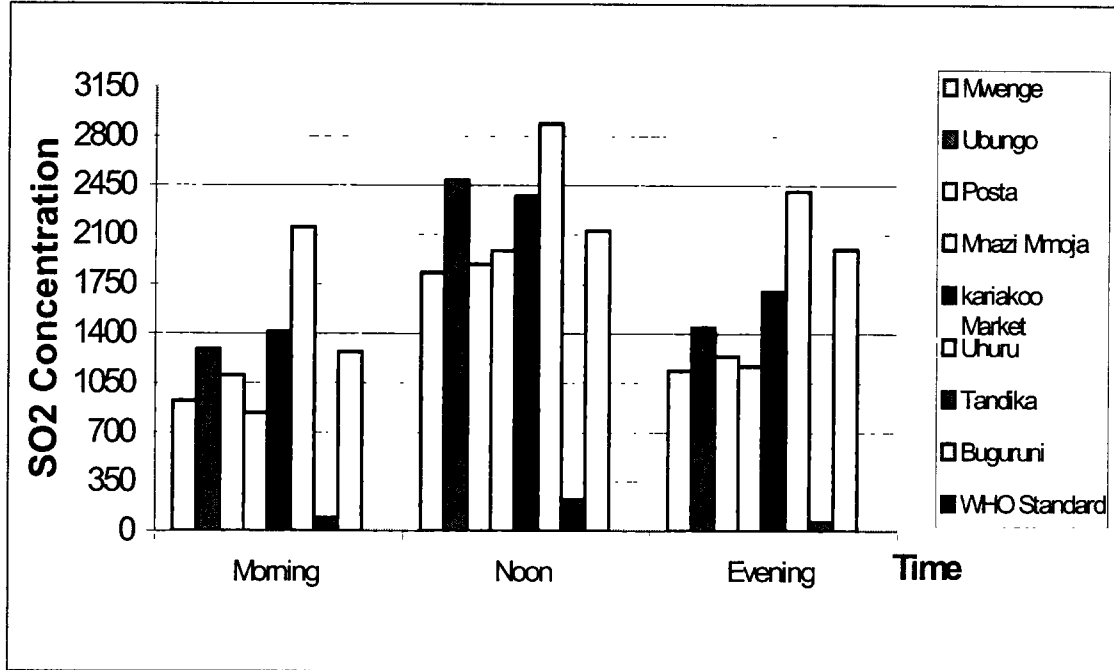

The above findings indicate that the air in Dar Es Salaam is highly polluted, particularly with regard to sulphur dioxide, suspended particulate matter and lead. Vehicular emissions are mostly responsible for this condition.

4.2.2 Biological Environment

4.2.2.1 Current Vegetation Cover

The vegetation of the city of Dar Es Salaam is characterized by a varied mosaic of vegetation with shade trees, lawns, hedges and planted gardens, mostly of exotic nature, with almost all the natural vegetation having been lost. Main characteristics of that vegetation are described below and documented in the Vegetation Photographic Report included in Annex 6.

Although documented information on historical distribution of natural vegetation could not be found during the undertaking of this study, it is understood that the natural vegetation of Dar Es Salaam has been considerably removed/modified by anthropogenic activities due to urbanization as well as urban agriculture. The vegetation of Dar Es Salaam is therefore dominated by what is termed “urban vegetation”. Most of the natural vegetation left comprises mangroves and natural grass and to a lesser extent baobab trees. A mangrove ecosystem is present along the coast of the Indian Ocean. Extensive growth of mangroves can easily be seen near the mouths of the rivers Msimbazi and Mzingu; and on Kunduchi beach.

The remaining vegetation has been classified into five groups, with respect to vegetative structure.

Tree Groves

Tree groves are commonly seen in the city’s parks like the Old Post Office Park, Mnazimmoja, Vijana, Kalimjee, Leaders Club grounds etc,. The trees vary in height, spacing, and crown shape, depending upon the species planted and the planting design. Such trees provide a continuous canopy. Most common trees are bush fig (mkuyu in Swahili) [*Ficus sycomorus*], neem (mwarobaini in swahili) [*Azadirachta indica*] (mwarobaini), yellow cassia (mjohoro in swahili) [*Senna siamea*], peacock flower (mkenge in Swahili) [*Albizia saman*], and Barbados almond (mkuyu in swahili) [*Terminalia catappa*].

Street Strips

Street trees are planted in strips along almost all the streets in the city. Typical areas with very large and old street trees are along Samora Avenue, Sokoine Drive, Morogoro, Msimbazi, Kawawa (project roads), Nyerere, Mandela and Ocean roads, Luthuli, Zambia, Shaaban Robert and Ohio streets, Oyster Bay, Masaki areas, etc. Street tree strips show significant variation in spacing of the trees. Both continuous and discontinuous canopies can be observed. Common trees are Christmas tree (ashock in Swahili) [*polyalthia longifolia var pendula*], neem, and different species of palm trees and peacock flower.

Shade tree / lawn

Shade trees and lawns are commonly seen in residential areas as well as in government institutional, social and commercial areas like colleges, office buildings, hotels, and pubs (especially in the city’s outskirts). There are structural variations in the shade tree/lawn type when a large number of species are incorporated in the landscape. Examples of areas where such vegetation can easily be seen are along Ali Hassan Mwinyi road, Kisutu and Kivukoni courts, High Court of Appeals, Kilimanjaro, New Africa and Movenpick hotels. Common trees for shading are yellow cassia, peacock flower, and neem.

Lawn

Lawns are structurally the most uniform vegetative units in Dar Es Salaam in terms of density. A variety of grass species are used which are maintained at a uniform height and form continuous ground cover. Lawn vegetation can be seen all along double lane roads (e.g. Morogoro, Kawawa, Mandela, Nyerere roads) and on street sides.

Shrub cover

Shrub cover is more limited in distribution than the other structural types. Hedges represent a variation of the urban shrub cover type. Shrub covers include such species as bougainvillea and governor's plum (mchongoma in swahili) [*Flacourtia indica*]. Species, planting design, and maintenance control the structural characteristics of this types. Shrub cover is mostly seen in residential areas where it is used as a fencing plant.

Other vegetation covers

Other important vegetation covers worth mentioning are the vetiver grass and flood plain vegetation. Vetiver grass, which has successfully been used for stabilization of embankments and slopes can be seen on the Indian Ocean shore (along Sokoine Drive) and Kimara Baruti.

Due to poor drainage, the flood plain vegetation consists of mostly wooded grassland, with very small canopy covers. Such vegetation can be seen in Jangwani and Msimbazi valleys flood plains. General characteristics of flood plain vegetation can be seen in **Annex 6**.

4.2.2.2

Fauna

The fauna of Dar Es Salaam consists of terrestrial and sea creatures. Terrestrial creatures consist of such domestic animals as grazing cattle, goats, pigs, and chicken and different types of birds. While domestic animals are mostly kept in the outskirts of the city, birds including crows and other small local birds and peacocks reside in tree groves, street strip vegetation, and flood plains. Peacocks can easily be seen at Karimjee Park and State house.

4.2.3 Socio-Economic Environment

4.2.3.1 Population

The city of Dar Es Salaam is estimated to have slightly over 3 million people in 2007. This represents almost 8% of the national population and 30% of the national urban population.

DSM is considered as one of the fastest growing cities in sub-Saharan Africa. The city's population is growing at an annual rate of 4.3%. During the last National Population and Housing Census conducted in 2002, the city had 2,487,288 people thus making its average density to be around 1,125 people per hectare.

DSM city currently covers an area of 1,800 square kilometers of which 1,350 square kilometers is land and the rest is water body. The city spreads over the territory of three municipalities: Ilala, Kinondoni and Temeke. The DART project will intercept the territory of only the two first.

The table below gives the population growth of Dar Es Salaam for the past fifty years from 1948 to 2007. The population growth trends depict a double population figure every ten years.

**Table 4.2.3.1.a
Dar Es Salaam Population Growth 1948-2007**

YEAR	POPULATION
1948	69,277
1957	128,742
1967	356,286
1978	843,090
1988	1,360,850
2002	2,487,288
2005*	2,822,142
2006**	3,015,679
2007**	3,070,060

Source: Population Census, DCC (2006), DCC (2006)

* Estimate by Dar Es Salaam City Council based on 2002 Census

** Estimate in Citywide Strategy for Upgrading of Unplanned and Un-serviced Settlements in Dar Es Salaam (Draft Report)

The table below shows the distribution of Dar Es Salaam's population by sex and between each one of the three municipalities whose territory is occupied by the city. Projections for 2007 are based on the growth rates observed in 2002.

Table 4.2.3.1.b
Current and Projected Population Growth of DSM's three Municipalities

Municipality		Year		
		2002	2005*	2007*
Kinondoni	Male	547,081	620,732	675,263
	Female	536,832	609,103	662,612
	Total	1,083,913	1,229,835	1,337,875
Ilala	Male	320,408	363,543	395,480
	Female	314,516	356,858	388,207
	Total	634,924	720,401	783,687
Temeke	Male	387,364	439,513	478,124
	Female	381,087	432,391	470,374
	Total	768,451	871,904	948,498
DSM	Male	1,254,853	1,423,788	1,548,867
	Female	1,232,435	1,398,352	1,521,193
	Total	2,487,288	2,822,140	3,070,060

Source: United Republic of Tanzania 2002 Population and Housing Census – *Projections based on 2002 growth rate

According to the 2002 Household Survey, 7.5% of DSM's inhabitants are below food poverty line. Employment (41.7%) and self-employment (29.1%) account for 71% of household income in the city. The average household consumption expenditure was 21,949 TZS for 28 days and food purchases accounted for 52.2% of this expenditure.

Average household size in Dar Es Salaam is 4.2 persons per family. That is 15% smaller than the average household size in Tanzania (4.9 persons per family).

In 2002, 60.6% of the Dar Es Salaam population had attained primary school education and only 16.6% secondary education, indicating a low educational level.

Major reforms are however now underway in the primary and secondary education sectors and in 2005 a total of 419,590 pupils were enrolled in primary schools and out of these 96% were in government schools and the rest in private schools. Total enrolment in secondary schools in DSM city is 51,532 pupils. The 2006 directive by the Prime Minister to ensure that all primary school pupils who have passed their examinations in DSM must be enrolled in secondary schools will have major implications in terms of increased secondary school enrolment in the city.

Main educational statistics for the municipalities of Ilala and Kinondoni that will be intercepted by the DART project are shown in the table below. As can be seen, based on the 2002 Population Census, the literacy level in Ilala District was 91% among men and 87% among women. Similarly, literacy levels in Kinondoni District were 90% among men and 86% among women.

Table 4.2.3.1.c
Educational Attainment Level

Educational Attainment Level	Male (%)	Female (%)	Total (%)
Ilala			
Primary School	68.25	75.71	72.0
Training after primary	0.50	0.46	0.48
Secondary school	25.41	19.65	22.60
Training after secondary	1.50	1.59	1.55
University and others	4.09	2.31	3.22
Total	100	100	100
Kinondoni			
Primary School	72.28	75.90	74.05
Training after primary	0.82	0.88	0.85
Secondary school	20.94	19.38	20.19
Training after secondary	1.85	2.02	1.93
University and others	3.83	1.68	2.80
Total	100	100	100

Source: United Republic of Tanzania 2002 Population and Housing Census

The planning and implementation of local-level health services in Tanzania is carried out at the district level. In Dar Es Salaam, malaria and water borne diseases are the most commonly reported illnesses and malaria is the leading cause of death for both children under the age of five and the rest of the population. Malaria is of particular concern, both because of the high rates of incidence and because of the potential for the development of drug resistance. Water-borne diseases most present are typhoid and schistosomiasis.

The child mortality rates for Dar Es Salaam are provided in the table below (2000). They indicate that infant mortality rates for Dar Es Salaam are far lower than the national level.

Table 4.2.3.1.d
Infant & Child Mortality Rate

Age	Neonatal	Post neonatal	Infant Mortality	Child Mortality	Under Five Mortality
0-4	31.7	55.7	87.5	53.7	139.5
5-9	41.4	60.1	101.5	58.5	154.1
10-14	46.8	55.4	102.3	70.8	165.9

Source: Ministry of Health: Demographic & Health Survey 2000

The causes of high morbidity and mortality are largely associated to easily preventable diseases. Poor nutrition, lack of clean water, lack of adequate health services, limited availability of medicines and affordability of private hospitals and clinics, are the main factors making health control difficult. However, the situation is comparatively better in urban areas than rural areas. In Dar Es Salaam, according to the 2002 Household Survey, 87% percent of households were found to consult modern health facilities and 66% were within 6 kilometers of a health facility.

4.2.3.2

Historic Urban Growth Patterns

Dar Es Salaam, unlike the old East African coastal towns of Kilwa, Zanzibar, Mombasa, Lamu and Malindi etc., is a relatively new town dating back to the 19th century. Sultan Seyyid Said Majidi of Zanzibar established Dar es Salaam as a port and trading centre in 1862. Later on its role changed to include administrative functions. The city grew rapidly from the early 1890s when the German Government selected Dar Es Salaam as the administrative headquarters of its newly acquired colony of German East Africa (including Kenya and Uganda), and started to plan the development of the town.

The buildings built to house the administration of that time remain as the hub of the current Government. The German colonial administration's *Bauordnung* or building code adopted for the development of the city and local government system was largely continued by the British who took over the administration of Dar es Salaam in 1916 up to 1961. Following the end of the Second World War, a Town Planning Department was established in 1947 and a Master Plan produced in 1948, followed by the adoption of Town Planning Legislation in the same year. The status of *municipality* was granted in 1949 while that of *city* was granted in 1961 at the attainment of the country's independence. Subsequently, Master Plans which were prepared in 1968 and 1979, and government policy generally have attempted with little success to meet the challenges associated with rapid urbanization as manifested particularly by housing shortage, proliferation of unplanned or informal and unserviced settlements, expansion of the informal sectors, poor sanitation and inadequate infrastructure and services.

Currently, the City of Dar Es Salaam covers an area of 1,800 km² of land which also includes areas of the offshore islands in the Indian Ocean. Area covered by bodies within its jurisdiction and which account for 450 km².

The population has been growing fast mainly through immigration and natural growth. In the years before 1948, Dar es Salaam was a small town and grew relatively slowly at 2.6 per cent per annum. After 1948, direct control of Dar es Salaam's development has been less easy, especially after independence in 1961, on account of the sheer numbers of people added to the city per annum and lack of capacity to manage a rapidly growing large urban centre. The city population grew at an impressive rate of more than 7 percent per annum (see Section 4.2.3.1). Therefore, most of Dar es Salaam's growth is a post World War II phenomenon.

Since 1961 when Dar Es Salaam was granted the status of *city*, it has continued to grow under the auspices of different policies especially under the Decentralization Policy whereby Urban Councils were dissolved. This lasted until 1978 when the Councils were reinstated in selected urban areas.

After 1948, urban spatial expansion started to grow without control. Inadequate institutional capacity coupled with inadequate financial resources and insufficiently multifaceted approaches in managing a large city has resulted into the urban area spreading rapidly in an uncontrolled and disorderly manner featuring an urban sprawl situation. In fact, most of the city population lives in informal housing areas that have been built by residents themselves in many parts of the city to fill in the huge gap created by failures of formal urban development and management system. Taking advantage of existing radial infrastructure networks, spatial development tends to concentrate along the coast line and follows the arterial roads of Ali Hassan Mwinyi (Bagamoyo), Morogoro, Nyerere (Pugu), Kilwa, creating a finger-shaped type of development. Inadequately planned infrastructure development has resulted in spatial development of the city areas with deficient infrastructures and services.

This spatial growth of the city has created a finger-like urban development pattern emerging from the better-serviced old planned residential areas and also concentrating along the arterial roads and the coastline, thus giving the city a linear type of development. This pattern has created underdeveloped and poorly serviced land pockets between the arterial roads. The historical evolution of this pattern can be seen in **Figure 4.2.3.2.a** which shows the sequential evolution of the urban area between 1947 and 2004. Population density by zones is shown in **Figure 4.2.3.2.b**.

For much of the time, the growth of the city has been guided by Master Plans and the last one (as explained earlier) was drawn up in 1979.

The Master Plans needed revision; instead, it was agreed to introduce a Strategic Urban Development Plan (SUDP) for the city. The SUDP gives the basis for the preparation of detailed plans for specific areas.

This document stems from The Sustainable Dar Es Salaam Project (SDP) and was prepared as an output of the ongoing Environmental Planning and Management Process (EPM).

Figure 4.2.3.2.a
Sequential Evolution of the Urban Area

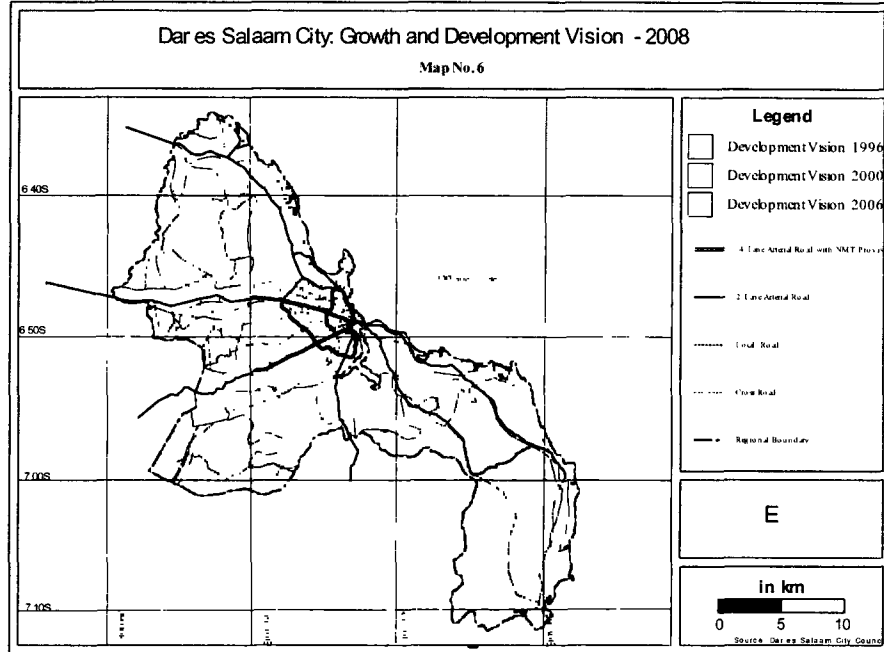

4.2.3.2.b
Population Density by Zones

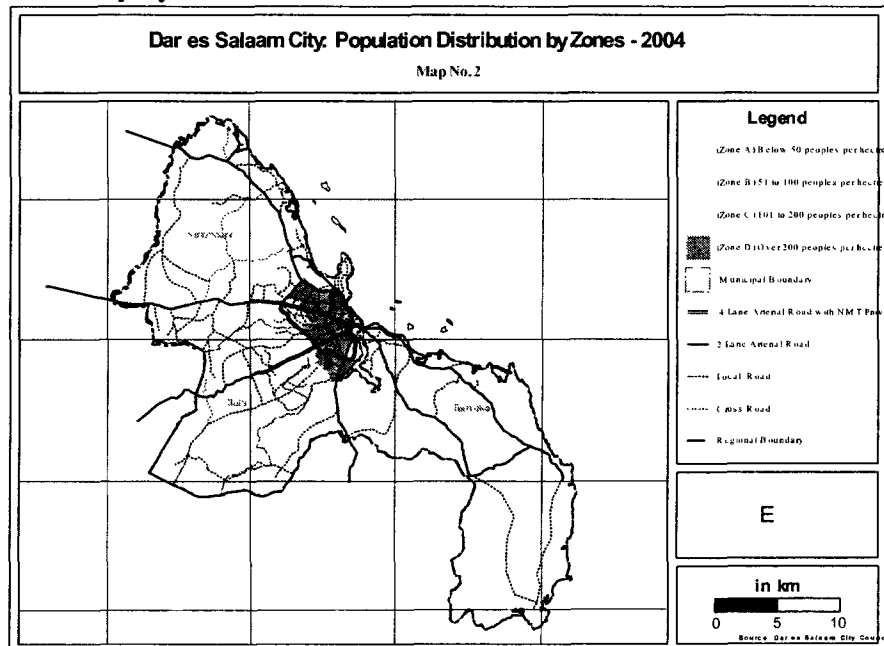

Urban Structure

The urban structure of the city of Dar Es Salaam is largely dissected into three major zones:

(a) The Central Business District (CBD)

The CBD is the hub of the city that mainly contains government/public buildings, high-rise structures that accommodate large businesses, public transport terminals, commercial enterprises, historic sites, hotels and public institutions.

(b) The Service Sub- centres

These feature a mixture of urban uses with higher densities and are concentrated along the main radial corridors. In the service sub-centers there is significant concentration of commercial activity, although mostly composed of small retail and service establishments. Most residents of the sub-centers have to travel to the CBD for many of their daily needs such as banking and medical treatment.

(c) The periphery

The main activity is agriculture and livestock-keeping with minimum residential density.

The main roads in the city link up the various service sub-centers and constitute semi-continuous commercial corridors along which intensity of commercial activity increases with proximity to sub-centers. It is worth noting that strengthening of service sub-centres and/or creation of new ones is part of the city's planning strategy and aims at relieving the congestion in the CBD.

Areas between radial corridors are generally less valuable and occupied predominantly by unplanned settlements (illegally built neighborhoods) built by residents themselves on and without adequate planning or proper infrastructure. Neighborhood access in many such parts of the city takes place through a series of walking paths between houses and buildings following no planning patterns whatsoever.

The ever-growing informal sector of the economy, in which people seek economic survival, is reflected in extensive areas of unplanned housing. High rates of unemployment, underemployment, and poverty generate acute social problems that overwhelm city administration and its three municipalities that are understaffed and under-funded.

Dar Es Salaam city also exhibits a high rate of immigration and this further strengthens the tendencies for high growth rates in less valuable areas outside the main commercial corridors and between sub-centers.

As illustrated by this description, the main road system is one of the major elements affecting urban structure and influences densities and the spatial distribution of land uses.

Figure 4.2.3.3.a illustrates the hierarchy of subcentres in the City of Dar Es Salaam and their position with regard to the main road system. **Figure 4.2.3.3.b** illustrates the existing land use patterns within the city, discriminating between planned and unplanned areas. Semi-isolated rural villages within the IAA as well as main industrial areas are also shown.

Figure 4.2.3.3.a
Existing Land use Patterns

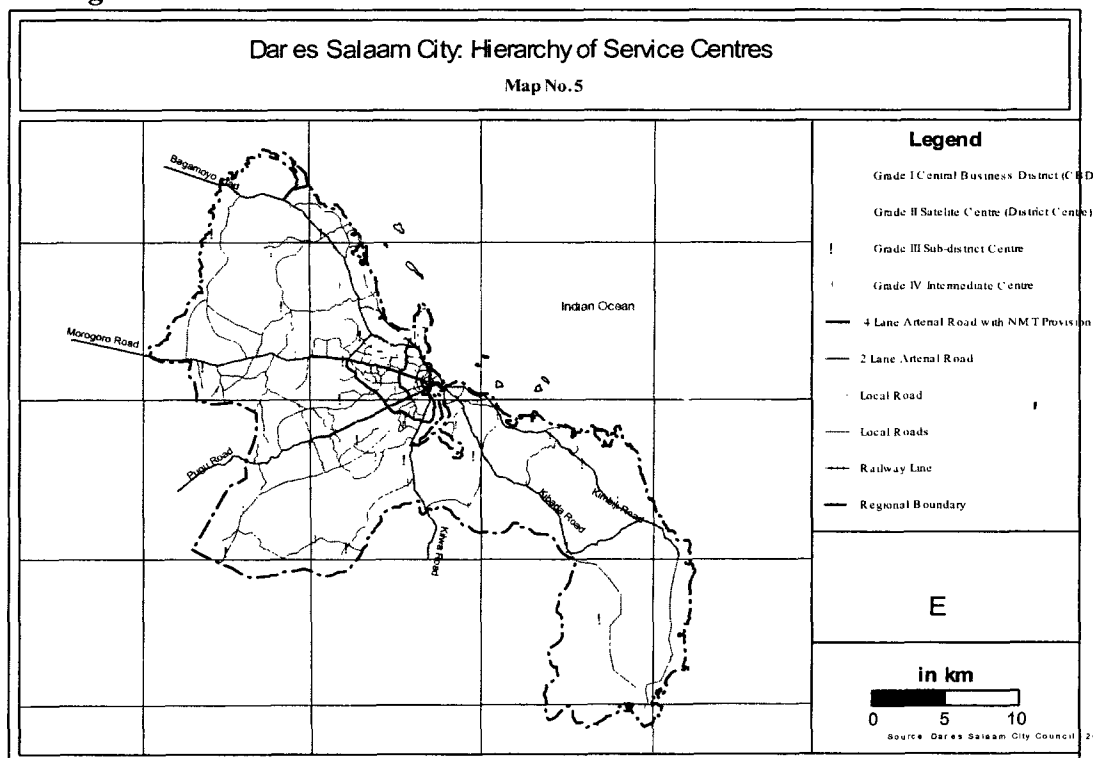

The full variety of urban land uses occurs both in planned and unplanned areas. These include residential uses (low, medium and high density neighbourhoods), institutional, commercial, industrial uses and open spaces.

In Dar Es Salaam, it is estimated that about 70% of the population live in unplanned settlements. Housing densities in these areas reach 480 people per hectare and 35 units per hectare on average. These densities are above recommended standards of 22 houses and 225 people per hectare.

Another major factor affecting Dar Es Salam’s urban structure is the natural drainage system. The Msimbazi river and Jangwani valley create a major physical barrier in a predominantly Southwest to Northeast direction. Similarly, the Sinza river creates a barrier in the West – East direction, approximately parallel to Morogoro Road. These physical barriers determine the limits of the “traffic contribution areas” of some of the major roads in the city and hence affect their relative commercial importance.

Figure 4.2.3.3.b
Existing Land Uses

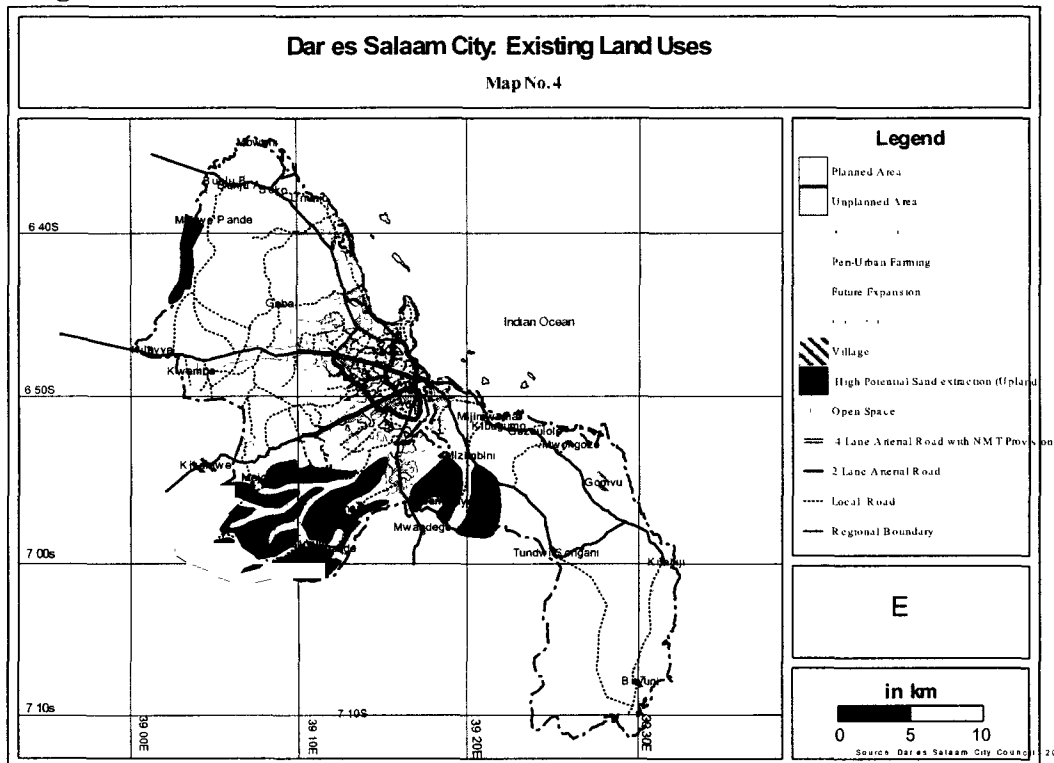

4.2.3.4

Transportation Infrastructure

- Road Network

The road system in Dar Es Salaam is insufficiently developed for a city of its size. Road capacity is generally inadequate and fully operational and properly paved roads are scarce. This explains the extent to which much of the city's urban structure, as described in Section 4.2.3.3, is a result of the structure of the road network.

There are approximately 1,140 km of roads in Dar Es Salaam and only 450 km are paved (39.5%). Sidewalks are in most cases inexistent. Even where they exist in downtown, they are mainly occupied by parked cars. Sidewalks are not paved in general.

The road system does not have the required density to develop proper urbanization. It is advisable to develop a network to improve access to the city with a clear priority to non motorized transportation.

The potential for improving city connectivity through development of road infrastructure becomes evident when comparing Dar Es Salaam's situation, where there are only 0.84 km of roadway per Km², with a road density over 5 km per km² which is typical of dense urban areas.

The quality of the urban paved roads varies over time depending on maintenance procedures. Roads getting regular maintenance are mostly of good quality while those lacking maintenance are in poor condition. The earth road network is mostly characterized by pot-holes and worn out surfaces. In general, road maintenance is low profile and most roads are of poor quality.

Only 265 km of road are used by public transportation. This is partly because daladalas are prohibited from running on most of the roads in the downtown area and/or because most of the roads are in extremely bad condition making the only option those streets in acceptable or good condition.

As mentioned in Sections 4.2.3.2 and 4.2.3.3, the city developed along the axes of former roads linking to neighboring cities (Bagamoyo, Morogoro, Pugu and Kilwa) that now are the main avenues, while Uhuru road originally developed as a back street to the Pugu Road.

Currently, the main road network is predominantly radial and with mixed traffic operation (cars, daladalas and trucks). Characteristics of the most important radial roads are as follows:

- Kilwa Road – Two- lane undivided roadway.
- Nyerere Road – Four- lane divided roadway between the airport and Bibititi Road.
- Uhuru Road – Mostly two lanes undivided.
- Morogoro Road – Four- lane divided roadway between Kimara and Bibititi Road.
- Bagamoyo Road – Two- lane undivided roadway until Kawawa Road.
- Ali Hassan Mwinyi Road – Four-lane divided roadway from Kawawa Road until it becomes Bibititi Road.

In the North – South direction there are three well-defined peripheral corridors and two non-continuous ones:

First peripheral circle, from Bagamoyo Road to Bandari Road:

- Sam Nujoma Rd. – two lanes undivided along with Nelson Mandela Rd. – four divided lanes.

Second peripheral Circle, from Ali Hassan Mwinyi Road to Kilwa Road:

- Kawawa Rd. – four-lane divided roadway with Chang’ombe Rd. - two lanes undivided.

Third Circle, from Ali Hassan Mwinyi Road to Nyerere Road:

- Bibi Titi Rd. – four-lane divided roadway.

Non continuous peripheral corridors:

- Msimbazi Rd. – mostly two lanes undivided.
- Gerezani St. – two lanes undivided.
- United Nations Rd. – two lanes undivided from Ali Hassan Mwinyi Rd. to Morogoro Rd.
- Shekilango Rd. – two lanes undivided from Bagamoyo Rd. to Morogoro Rd

Configuration of the main road network described here is shown in **Figure 4.2.3.4.a**

Figure 4.2.3.4.a
Main Road Network

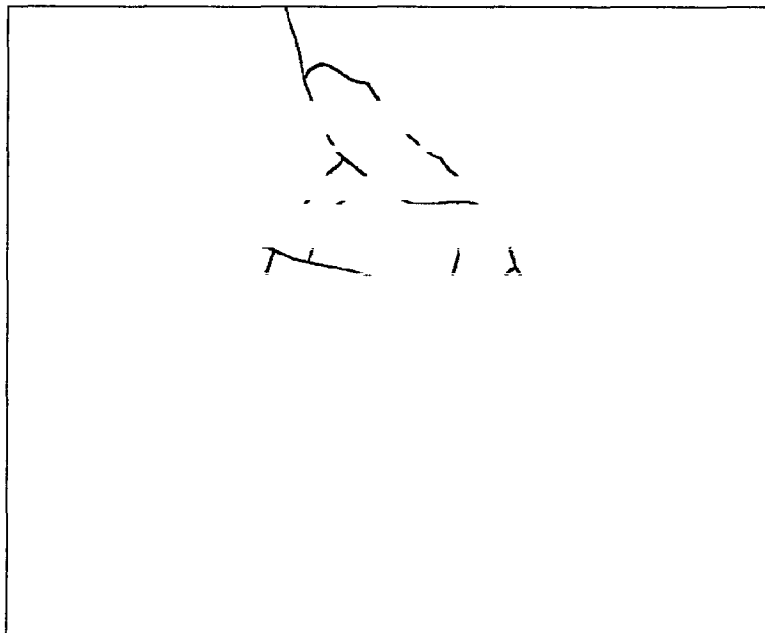

Traffic conditions along this limited road network are highly congested. This is due to the increase in private car ownership, non-segregation of traffic, poor condition of the roads, non-functioning of traffic lights and lack of adequate road signs. Critical analysis of existing traffic has pointed out inadequate intersection design as a key problem. Most intersections allow for the full range of movements, including right-turns, and this requires use of four-staged stop signs that significantly limit time available for main road traffic.

The city is also prone to traffic accidents (accounting for about 40% of all traffic accidents in the country). Most accidents occur at the busiest junctions along arterial roads. Causes of accidents are: human error, malfunctioning of traffic lights, condition of vehicles, lack of effective enforcement of traffic etc.

There also a chronic problem of lack of parking space in the CBD. It is reported that there are at present about 2,500 on-street parking spaces to cater for all the traffic entering the CBD.

- Vehicle Fleet

The total estimated vehicle fleet in Dar Es Salaam is around 80,000 vehicles, of which approximately 47,000 are private cars and 8,000 are daladalas, the remainder being 25,000 commercial vehicles.

The car fleet is growing fast and as mentioned above, the city is already facing traffic congestion. The daladala fleet lacks overall maintenance. Most daladalas (90%) are more than 10 years old. 54% are more than 15 years old. 19% are 20 years old or more.

The daladala fleet is comprised of three main types of vehicle: the Hiace “Kipanya” van for 17 seated passengers, that during peak hours may get packed with up to 30 passengers; the “Coaster” minibus for 30 seated passengers reaching a maximum of 50; and the “DCM” which is a slightly bigger minibus with a capacity of 40 seated passengers with an estimated maximum capacity of 65 passengers.

Being the oldest and worst maintained fleet, the DCMs are currently running mostly on the southern routes of the city. The Coaster fleet, some of whose vehicles are in good condition, run on northern and some western routes. Kipanyas are widespread all over the city and their state varies from good to completely decaying vehicles.

From the counts the Kipanya type is the most common daladala representing approximately 70% of the active fleet, 20% are Coaster and 10% DCM. It is estimated that total current daladala fleet includes 7,500 vehicles.

- Public Transportation Routes

Prior to the survey, 181 daladala routes were officially recognized. After the frequency and occupation surveys conducted during planning of DART Phase I were completed, approximately 255 daladala routes were identified. The existing system is very dynamic, and has a good identification scheme based on colors painted on the bus, to display which corridor is used for which route.

The color and the route name are painted on the vehicles, so that the driver can't change routes.

The routes are more concentrated along Morogoro Road (35 routes), Uhuru Street (38 routes) followed by Kilwa Road (25 routes).

Routes cover part of the existing urban roads, even though road conditions are bad. Walking distances to reach public transportation are high.

The volume of vehicles and passengers identified in surveys show a concentration of demand on the main corridors; as expected, Morogoro Road is the busiest one, followed by Kawawa Road and Uhuru Street. From the analysis it is clear that despite the fact Uhuru Street does not offer the highest demand figures, it has considerable high demand along with a high vehicle flow volume, due to the predominance of small daladala routes running along it. Section 2.5 included a description of current distribution of daladala routes in Dar Es Salaam.

The number of routes, of course, is not proportional to the total number of buses passing along each corridor, as the routes have different frequencies (one route can have one bus every two hours, while other can have ten buses per hour). The number of buses is not constant throughout the day either. For the peak hour in each of the five (05) radial corridors, the total number of buses and passengers are as presented in the table below.

Table 4.2.3.4.a

Passengers and public transportation vehicle volumes on peak hour

Road	Passengers /hour	Vehicles/hour
Morogoro Road	15,000	770
Uhuru Street	9,000	715
Kilwa Road	6,200	549
Kawawa Road	10,000	383
Nyerere Road	8,600	399
Ali Hassan Road	5,100	281

Daladala fleet ownership is highly fragmented, with many individuals owning their own vehicles. According to City Council information, neither cooperative forms of organization nor private company that own and operate daladala fleets exist. The Usafiri Dar Es Salaam Company (UDA) owns 30 commuter buses. The City Council of Dar es Salaam holds over 51% of the shares in this company.

- Current Daladala Route Operational Indicators

The daladala system is very dynamic, with new routes being created everyday as well as alternative routes, so as to be closer to demand. As a consequence it creates a relatively poor service (really crowded buses in peak hours, and full buses with low off-peak frequencies), that charges very low fares.

The most important operational indicators for evaluation of the system are:

- Average speed (peak and off-peak);
- Passenger/km (PKI), which is the average number of passengers collected on a trip divided by the length of the trip;
- Turnover index (TI), which is the ratio of the maximum load inside a vehicle/trip divided by the total number of passengers boarding on that trip.

PKI and TI significantly affect the costs (and/or profitability) of a route. PKI indicates how many kilometers it is necessary to travel to collect a fee from one passenger. TI indicates how many times available bus space (seated or standing) is used during a trip, and hence how many times a fare is collected for occupancy of one space on that route, regardless of its length.

Surveys conducted allow for the following evaluation of daladala operations:

- PKI varies very significantly between routes. Some can be considered good (over 3 passenger/km) but others are probably not profitable or only marginally profitable (less than 2 passenger/km).
- TI is high for low capacity vehicles, ranging from 1.1 to 2.03 with an average of 1.4.
- Traffic congestion is generally responsible for low velocity flow along the main corridors. Confusion about daladala stops also contributes to reduction of the overall route speed. Speeds range from 4.1 to 32 km/h with an average of 14.4 km/h at peak hours and going up to 19 km/h during off peak hours.
- Average bus occupancy is 22 passengers per vehicle at peak hours and 18 pass/vehicle at off-peak hours for small daladalas and 34 pass/vehicle and 24 pass/vehicle for big daladalas for the same periods.

The number of passengers per kilometer can be considered high when comparing with the size of vehicle. This is explained by the overloading of the vehicles which provides a very poor service.

Speeds normally are high for small vehicles since they usually rush when they are running full, explaining the low values for turnover (near to 1) and how the system can survive with a very low fare.

Table 4.2.3.4.b
Current Daladala Fleet Performance Parameters

Parameter	Peak	Off-Peak	Average
Average speed (Km/h)	13.5	19.8	
PKI (pass/km)	2.5	2.0	2.3
TI	1.3	1.5	1.35

- Travel Patterns

Survey work concluded during the DART Phase I planning process confirmed that the majority of the inner city trips are made by public transportation or by non motorized transportation modes as follows:

- 43% of trips are made by public transportation (daladalas).
- 45% of trips are made by non motorized transportation.
- Only 6% of trips are made by private cars.

Daladals carry approximately 1.4 million passengers per day. Approximately 200,000 trips are made daily by private transport. Car trips are mostly concentrated in the downtown area along Old and New Bagamoyo Roads, where the upper class inhabitants live.

Due to the fact that the city has developed around few main roads since it lacks a good road network structure, supply and demand of public transport are concentrated along these corridors. This situation has led to the proliferation of daladala routes and a high volume of these, along the developed corridors. At peak hours the biggest circulating traffic share belongs to daladals.

The origin-destination (O/D) survey conducted during the DART Phase I planning process, showed that destination of trips is highly concentrated on certain areas such as Kariakoo market, Downtown Center (Posta), and Muhimbili Hospital, these being the major and most frequented institutional and commercial centres within the city. Other areas with considerable demand are Ubungo, Mwenge and Kimara.

4.2.3.5

Other Physical Infrastructure / Utilities

Water Supply

The Dar es Salaam Water and Sewerage Authority (DAWASA) is the body responsible for the provision of water supply and sewerage services in the Greater Dar Es Salaam area covering Dar Es Salaam and part of the Coastal Region. DAWASA has incorporated the Dar Es Salaam Water Supply Company (DAWASCO), a private firm, to operate and manage the distribution system within the city. DAWASA has used the Ruvu River as its main water source since the 1950s. The upper Ruvu scheme has a capacity of 81 million liters a day (Mld) while the Lower Ruvu intake has a design capacity of 182 Mld. Other sources are at Mtoni to the South of the city and have a capacity of 9 Mld.

The approximate length of existing mains in the city is about 824 km, with 237 km of primary distribution and 587 km of secondary distribution. There are free standpipe supply points around the city and various vendors distribute water to customers by carts and other by private vehicles in neighbourhoods not currently served by water distribution networks.

Where networks exist, water is distributed to the city residents, institutions and industries through metered connections. The distribution system is currently undergoing rehabilitation by laying new lines and replacing old ones.

Almost 60% of distributed water is for domestic (residential) consumption, 20% for industrial use, 10% for commercial purposes and 10% for institutions. There is an estimated deficit of around 250 Mld.

Sewerage System

The sewerage system of Dar Es Salaam is really a collection of independent micro-systems, rather than an integrated network. The city center and immediate surrounding areas are served by a sewer network which ultimately discharges to the Indian Ocean via an outfall. Others are centered around institutional areas such as the airport and the Dar Es Salaam University. The system which uses a combination of gravity and pumping is comprised of the following:

- Nine stabilization ponds sites,
- Fifteen sewerage pumping stations
- Approximately 170km of gravity sewer and pumping mains
- A 1 km long, 1000mm diameter ocean outfall and screening house.

Currently, there are ongoing rehabilitation works for sewerage in the CBD and in Kariakoo.

Less than 55% of the population is served by the sewer collection system. The rest of the population depends on site disposal systems, particularly septic tanks and pit latrines.

Storm Drainage

The city has 1,100 kilometres of open lined drains and 600 kilometers of piped storm water drains which collect rainwater and discharge in the natural drainage system. The main river in the city is the Msimbazi river which has a very large flood plain (Jangwani valley). An affluent of the Mzimbazi, the Sinza river, also has a very significant catchment area which is mostly urbanized.

Flooding is a chronic problem in many parts of the city and generally occurs in lower regions and along the more important flood plains. However, because of lack of regular maintenance, the drainage system frequently gets blocked and flooding can occur even in relatively high areas.

Power Supply

The Dar Es Salaam power supply system is controlled by the state owned Tanzania Electric Supply Company (TANESCO). Electricity supply is mainly hydro-based with three main generation stations located in different parts of the country and linked together through the national grid. The total generation capacity is about 500 MW, which matches demand.

In order to increase generation, in 1992 the Government changed its policy to allow private participation in power generation, resulting in the formation of two main companies, Independent Power Tanzania Limited (IPTL) and SONGAS, both located in Dar Es

Salaam. These two sell their power, which is integrated into the national grid, to TANESCO.

The hydro-based system has not been operating to capacity recently due to shortage of rains which provide the water to the dams. This has resulted in power rationing causing a lot of inconvenience to the city residents and also to the industrial sector.

Power distribution to the city is generally well spread covering all the developed areas. However, the city lacks adequate street lighting. Also, power failures are very frequent and can significantly affect traffic conditions since stop signs cease to operate.

Communications Systems

The fixed wire telecommunication network in the City of Dar Es Salaam is operated by the Tanzania Telecommunication Company Ltd (TTCL). TTCL is partly owned by the Government of Tanzania with 36%, the rest belonging to strategic partners/investors. Of late TTCL has introduced a wireless network that is also used for data transmission.

There are various mobile phone providers including TIGO (Formerly Mobitel – MIC Tanzania Limited), VODACOM (Vodacom Tanzania Limited), ZANTEL (Zanzibar Telecoms Ltd) and CELTEL (Celtel Tanzania Limited). There are 12 internet providers and 6 public data operators registered with the Tanzania Communication Regulatory Authority (TCRA).

The city is home to 4 television stations and about 10 radio stations, mostly privately operated.

4.2.3.6

Social Infrastructure

Although the city of Dar Es Salaam is the power house of economic and commercial activities in the country the fast population growth rate among many other factors has exerted pressure on social services which have not always kept pace. Main characteristics of health and educational facilities are described below. Availability of parks and other open spaces available to the population is also discussed.

Health Services

Dar Es Salaam is served by one of the oldest (1956) and best equipped government referral hospitals, the Muhimbili Hospital, which is also home to the College of Medicine of the University of Dar Es Salaam. This has a capacity of 1,400 beds with an average of 1,000 out-patient attendees per day. There are also three municipal hospitals at Temeke, Mwananyamala and Amana with over 140 bed total capacity. These are complemented by

privately operated hospitals like the Aghakhan, Regency, Hindu Mandal and St. Bernard among others, with a total capacity of over 1,000 beds.

The city also has 5 health centers and 54 dispensaries. Each Municipality has at least 250 pharmacies rising to 500 in the case of Kinondoni Municipality (*data sourced from HMIS report 2001*).

Educational Facilities

The City of Dar Es Salaam has a total of 223 primary schools of which 149 are Government owned and 74 are non-Governmental. Average primary enrolment is 360,000 in 3000 classrooms giving an average of 120 pupils per classroom. This is a clear indication of overcrowded class rooms. 160 registered secondary schools are run and operated by the Government (2), Community Organizations (14), non-governmental systems (102) and 42 are Seminaries. Secondary school enrolment topped 425,000 in 2004 rising from 200,000 students in 1995.

There are several universities and University Colleges as listed below:

1. Public Universities/University Colleges (Undergraduates and Post Graduates)
 - University of Dar es Salaam
 - Muhimbili University College of Health Sciences
 - University College of Lands and Architectural Studies
 - Open University of Tanzania
2. Private Universities/University Colleges
 - Tumaini University – Dar es Salaam College
 - Hubert Kariuki Memorial University
3. Technical Education Institutions
 - Dar es Salaam Institute of Technology
4. Institutions Under Other Ministries (not Ministry of Education)
 - Institute of Finance Management
 - National Institute of Transport
 - College of Business Administration

Enrolment in institutes of higher learning reached 6500 in the 2003/2004 academic year.

Parks and Open Spaces

The exact area of existing open space in the city is not available. This is partly due to the fact that most open spaces used by the population are not formally established public parks. Thus, many open spaces are transitory and the current amount of space available to the population is likely to decrease in the future. It is estimated that around 400-500 ha. of open spaces are used for crop cultivation in Dar es Salaam.

A study carried out in 1999 by Stefan Dongus established that there are 177 open spaces covering an area of 520 ha. The major part of the 520 ha is owned by institutions (56%), 35% is publicly owned and 12% is privately owned. Most of the area is army land (31%), the rest is located within settlements (24%), along river valleys (15%), in industrial areas (13%), along railway lines (7%) and along main power lines (4%). Some 3% belongs to schools.

The most significant open spaces are the army site in Kawe/Makongo area, along the railway line especially near TAZARA Station and along the Central Railway line between Vingunguti and Ukonga; the Jangwani valley and the University of Dar es Salaam.

High density residential areas like Manzese, Mabibo or Vingunguti have insignificant open areas. In the city center Kivukoni and Upanga, open spaces are practically non-existent except for the golf course at Upanga.

One of the major problems facing the city planners is irregular invasion of open spaces. Although the whole of the Jangwani Valley is declared "a hazard land" by the Dar es Salaam City Council and is thus not suitable for construction, there are many squatter buildings in place. This is in spite of the flooding that occurs frequently.

4.3

Direct Area of Influence

4.3.1

Physical Environment

4.3.1.1

Geology and Soils

The project covers an area of 20.85 km, starting at Kivukoni, near the ferry, and goes through Morogoro Road, up to Kimara. It also includes the Msimbazi Street from Morogoro Road to Kariakoo and the Kawawa Road from Morogoro Road to Morocco (Al-Hassan Mwinyi Road). The area covered by this study is the area within a 300m corridor on either side of the above roads.

The Morogoro road section between Kivukoni and Ubungo lies within the coastal plain while the Ubungo-Kimara section is within the Uplands. The coastal plain is a low-lying area east of Ubungo up to the sea. The coastal plain is subdivided into the lower and upper terrace. The edge of the lower terrace along the Morogoro Road is not clearly defined but may be along the Msimbazi River. However the Kinondoni stretch is marked by the raised reef steep slope near the grave yards and Ali-Hassan road is marked by the steep slope near St Peter's Church. The upper terrace lies between the Msimbazi creek and Ubungo upcountry bus station. The road starts at Kivukoni near the sea where the soils are mainly superficial white buff-sands underlain by grayish sands followed by calcareous sands and weathered coral limestone in certain areas. Grayish clayey sands underlie coral limestone.

The section between Kivukoni and km 1+000 is an old beach area with whitish beach sands near the surface followed by grayish brown clayey silt sands down to a depth of 15-20m. Whitish coral sands underlie the clayey silt sands followed by weathered coral limestone.

Further inland between Kivukoni and the Msimbazi creek the road crosses a relatively flat area with surface soils consisting of silt sands and clayey silt sands of low to intermediate plasticity.

The road crosses the Msimbazi creek. Msimbazi creek is a valley filled with alluvial and organic soils consisting of sands, silts, clays and gravels. The clays within the Msimbazi creek are expansive black cotton clays with high liquid limits and high plasticity. Msimbazi creek surface soils consists of expansive clay soils . Crossing the Msimbazi creek will require special construction methods.

The section between Msimbazi creek and Ubungo lies on the upper terrace with flat terrain. The surface soils consist of silt sands and clayey sands underlain by weathered sandstones.

The road section between Ubungo and Kimara crosses through the slopes of the Uplands. Here the soils consist of mainly dense clayey sands with brownish parches followed by kaolinitic clayey sands and sandy clays. The clayey sands contain swelling minerals and are not good as subgrade soils for roads. Road construction on the Uplands clayey sands often requires importation of improved sub-grade soils. The clayey sands are underlain by weathered sandstones.

The Msimbazi Street road section from Morogoro road to Kariakoo crosses the lower terrace. The top soils along this section are mainly silt sands of low plasticity. The thickness of the silt sand layer is approximately 10m. The silt sands are underlain by clayey sands of low to intermediate plasticity and are often interblended with coral limestones. The road will be built on sand soils with no construction problems.

The Kawawa road, from Morogoro Road to Morocco is on the upper terrace. The soils along this road are mainly silt sands underlain by clayey sands. The road section will cross the Msimbazi River flood plain filled with alluvial and organic soils consisting of sands,

silts and clays with substantial amount of organic matter. The near surface clays are mainly black cotton clays. Black cotton clays are widespread in the flood plain and are regarded as problem soils. Black cotton clays include clays and sandy clays with high linear shrinkage and high swelling pressure. Between Msimbazi flood plain and Morogoro the sub-grade soils are mainly silt sands and clayey sands of low plasticity.

4.3.1.2

Flood Plains and Natural Drainage Pattern

Within the Direct Area of Influence (DAI), the Jangwani Valley is the most significant flood plain. This intersects Morogoro Road in a perpendicular alignment and at this point is approximately 800 meters wide. Soils in this flood plain are very fertile and this is one of the factors that attract people to it.

People are also encouraged to live in this flood plain because rents are low, its close to the city centre, and there are opportunities for farming and agricultural activities. Besides that, the people here have low level of education.

In addition to squatters, some landfill has recently occurred upstream of Morogoro road and is being used as a cargo transfer area by trucks. Large trucks cannot enter the central area and they here transfer cargoes to smaller trucks.

The flood plains of almost all the rivers in Dar Es Salaam are considered to be flood hazard areas. These areas are affected by rising floods which occurs during heavy prolonged rain. Areas in the flood plain like Magomeni and Jangwani are flooded annually. People who are living in these areas have been told to vacate. Demolition of houses has started to be implemented purposely in order to reduce injuries, deaths, and property damage caused by floods.

The Sinza river has a far narrower flood plain. In this case, the valley's alignment is parallel to Morogoro Road. Thus, Sinza river will receive a significant part of the storm water runoff from the corridor area, particularly runoff from Morogoro road corridor between Ubungo and Kimara.

Urban drainage within the Direct Area of Influence is deficient, particularly along Morogoro Road between Ubungo and Kamara. Large drainage channels run parallel to the road but are frequently blocked at perpendicular street crossings. In many cases, the path of storm water is not fully canalized until reaching an existing outlet. Where channels exist, they suffer from unregulated disposal of garbage.

Urban storm water drainage is independent of the sewer collection system (mostly parts of Kinondoni and Magomeni within the DAI). However, only few people have been connected to the public sewer system, others are using septic tanks and pit latrines.

Unconnected houses tend to empty their septic tank and pit latrines during the rainy seasons.

4.3.1.3 Water Quality

Dar Es Salaam region has several rivers, but major rivers which cross the project area are only two, namely:

- Msimbazi river, and
- Sinza river.

Msimbazi river crosses the DART corridor at Jangwani valley along Morogoro road while Sinza river cross the project area at Mkwajuni area along Kawawa road. Water from these rivers is used for various purposes like washing and irrigation regardless of its questionable quality.

Msimbazi and Sinza rivers receive large quantities of untreated domestic waste waters from the city's residents and industries which contribute significantly to the pollution loads. As mentioned in Section 4.2.3.5, most of the city is not connected to the sewerage collection system. Unconnected houses use septic tanks or pit latrines which are emptied into the natural drainage during rainy seasons. Even the existing stabilization ponds may discharge to adjacent rivers.

A study conducted by E. Mbuligwe and M. Kaseva in 2005 shows that the Msimbazi river is polluted in terms of organic and nutrient concentrations, low dissolved oxygen, and high counts of indicator organisms. Biochemical oxygen demand (BOD₅) concentrations were 27– 340 mg/L. Dissolved oxygen was found to be as low as 0.9 mg O₂/L. Bacteriological pollution increased with distance downstream of the river, a trend attributable to an increase in the catchment of pollution sources, which are on-site sanitation systems (Mbuligwe and Kaseva, 2005).

Msimbazi and Sinza rivers are the most polluted due to the fact that they receive the largest quantities of untreated domestic waste from the city's residents and industrial uses. Measured water quality parameters for Msimbazi and Sinza river are shown in the table below (data for 2000). As can be observed, coliform levels are extremely high as is turbidity, particularly in the Sinza river.

Table 4.3.1.3.a
Surface Water Quality for Some Rivers in DSM

PARAMETER	Sinza River	Msimbazi River
PH	7.9	7.8
Electrical Conductivity (mS/cm)	820	680
Turbidity (NTU)	650	330
Colour (mg/l)	90	70
Appearance	Turbid	Turbid
Total Alkalinity	37.0	36
Carbonate hardness	37	36
Non Carbonate hardness	373	298
Total hardness	410	334
Total coliform/ 100mls	5.6×10^4	6.0×10^4
Fecal coliform/ 100mls	4.2×10^4	5.4×10^4

Source: Water Central Laboratory (2000)

4.3.1.4 Noise Pollution Profile

The main sources of noise pollution in Dar Es Salaam are traffic, industrial activity, construction activity, and social activities.

Studies have shown that there are some residential areas which experience noise levels from various sources such as social activities (bars, nightclubs, social halls) and small-scale service industries, resulting in community noise levels above 85dB(A), the recommended safe limit for occupational noise exposure for 8 hours (Mbuligwe 2004). Mbuligwe (2004) found that small-scale industries in Dar Es Salaam can present a serious source of environmental noise pollution.

Noise associated with traffic has three main sources: a) vehicles; b) friction between vehicles and the road surface; and c) driver behaviour.

Vehicle noise comes from the engine, transmission, exhaust, and suspension, and is greatest during acceleration, on upgrades, during engine braking, on rough roads, and in stop-and-go traffic conditions. Poor vehicle maintenance is a major contributing factor to this noise.

Friction noise from the contact between tires and pavements contributes significantly to overall traffic noise. Friction noise is generally greatest at high speed and during braking.

Drivers contribute to road noise by using their vehicle's horns (while calling passengers, in case of daladalas), by playing loud music, by shouting at each other, and by causing their tires to squeal as a result of sudden braking or acceleration.

A survey and analysis of noise and vibration from road traffic in Dar Es Salaam reported by Kassenga and Mbuligwe (1999), showed that noise and vibration levels are narrowly within World Bank threshold limit values (TLV) for industrial and commercial areas. However, in residential areas World Bank TLVs were exceeded.

Equivalent noise levels (LAeq) were generally found to lie between 65 dB(A) and 70 dB(A), with the New Post Office being an exception. The study revealed that road traffic is the worst source of noise pollution and singled out large vehicles (> 7 tonnes carrying capacity) as the worst polluters.

Noise levels recorded at Buguruni, Mabibo Junction (Morogoro Road), Lumumba, New Post Office, Shekilango and Pugu, are shown in the table below and compared with the applicable World Bank TLV.

Table 4.3.1.4.a
Noise pollution levels and traffic counts at measured stations

Road	Station	Traffic volume (v/h)	LAeq	Applicable World Bank Standard (PPAH) - Day	Applicable World Bank Standard (PPAH) - Night
			dB(A)	dB(A)	dB(A)
Mandela	Buguruni	1,297	68.13	70.0 ⁽¹⁾	70.0 ⁽¹⁾
Morogoro	Mabibo Junction	1,205	69.07	70.0 ⁽¹⁾	70.0 ⁽¹⁾
Lumumba	Lumumba	943	65.9	70.0 ⁽¹⁾	70.0 ⁽¹⁾
Maktaba	New Post Office	827	72.05	70.0 ⁽¹⁾	70.0 ⁽¹⁾
Shekilango	Mapambano	569	62.89	70.0 ⁽¹⁾	70.0 ⁽¹⁾
Pugu	Banana	440	63.22	55.0 ⁽²⁾	45.0 ⁽²⁾

NOTES:

(1) - TLV for industrial / commercial areas

(2) - TLV for residential areas

LAeq = equivalent noise levels.

Source: Mbuligwe, E (2007); and World Bank Group - Pollution Prevention Abatement Guidelines – PPAH.

Based on the above, it can be assumed that noise levels along the DART Phase I corridor are already very high and will probably not be significantly altered as a result of BRT implementation. However, in the case of some feeder stations which are at a distance from the main traffic corridor, as well as in the neighbourhoods surrounding terminals, bus depots and similar facilities (i.e. lateral and rear limits of Ubungo and Kariakoo terminals), baseline noise levels are not that high.

4.3.2

Biological Environment

4.3.2.1

Flood Plain Vegetation and Fauna

As noted in Section 4.2.2.1, the project area is adjacent to Msimbazi and Jangwani valley flood plains. The two plains are located along the River Msimbazi. The Msimbazi flood plain is located along Morogoro road, while Jangwani flood plain is located along Kawawa road.

The vegetation of the flood plains is characterized by wooded grassland. The vegetation pattern of the flood plain responds to water flow and the duration of flooding. Moving from relatively high ground within the flood plain to the river's edge, one experiences the following plant communities:

- Sparsely distributed mosaics of flood plain trees and shrubs.
- Dry grassland
- Wet prairies occupying the less saturated soils, and
- Aquatic plant communities occupying the saturated soils (very close to the river).

Tree species, mostly exotic, found in the flood plains consists of neem tree (mwarobaini in Kiswahili) [*Azadirachta indica*], yellow cassia (mjohoro in Kiswahili) [*Senna siamea*], peacock flower (mkenge in Kiswahili) [*Albizia saman*], and white mahogany.

The fauna of the flood plain is mostly local tree-dwelling bird species, and frogs.

4.3.2.2

Urban Vegetation and Landscaping

The vegetation of the project's Indirect Area of Influence (IAA) has been classified in Section 4.2.2.1 into tree grove, street strip, shade tree/lawn, lawn, and shrub cover. In describing the distribution of vegetation within the Direct Area of Influence (DAI), the study focuses only on the most notorious urban landscaping vegetation, specifically trees.

Trees along the corridor's alignment are generally of relatively small girths. However, some very large trees can be found particularly along Kivukoni Front and in other places of the Central Business District.

Along the rest of the corridor's alignment, urban landscaping vegetation is very poor and there are very few clusters of shade trees that are worth highlighting. In this context, vegetation is important because of its influence on right-of-way land use. "Shade" is an

important asset and shaded areas are occupied by bars and restaurants, taxi stops and other uses. Thus, significant clusters of shade trees have an economic importance as well as an environmental one.

The most significant vegetation along each section of Dart Phase I corridors is described below:

1) KIGAMBONI FERRY TO UBUNGO ROAD SECTION

From Kigamboni Ferry to Maktaba Street, the vegetation is mainly concentrated on street strips. (see plate 6) The trees consist mainly of Barbados almond (mkungu in Swahili [*Terminalia catappa*]), neem, yellow cassia, Indian date (mkwaju in swahili) [*Tamarindus indica*], and a few huge mango trees. The girths of the trees vary from about 30 to over 100 cm. Sokoine drive, which runs parallel to Kivukoni front road, is dominated by peacock flower trees.

Shade trees and lawn vegetation (see plate 7) can be seen around the following buildings: Ministry of Foreign Affairs, Navy Police Station, Kivukoni Resident Magistrate's Court, Kilimanjaro Hotel and Azania front Lutheran Church.

A strip of vetiver grass (see plate 8) stretches from the ferry daladala station to the Navy Police Station. Vetiver grass is important in that it serves to protect the beach from soil erosion by stabilizing the soil.

Opposite the old Post Office, grove vegetation is present in a recreational garden, which consists mainly of Christmas trees, peacock flower, yellow cassia and a few palm trees. Girths range from from 20 to 60 cm.

Strip vegetation consisting of Barbados almond and neem trees is found along the Kivukoni front road up to Sokoine/Mkwepu junction.

From Mkwepu/Sokoine Drive to Sokoine Drive/Morogoro Road, street strip vegetation consists mainly of Barbados almond trees, with a girth generally in excess of 70 cm.

Shade trees and lawn vegetation are found on the grounds of St Joseph's Roman Catholic Church and of Sokoine Drive Municipal Court.

Along Sokoine Drive, Morogoro and Bibititi, the street strip vegetation consists of yellow cassia, neem, ashock and Indian date, the girths of which vary from 20 to 90 cm.

Shade trees and lawns are found on the grounds of the UN Information Centre, the TACAIDS building, the Dar Es Salaam City Council Hall, and the Mtendeni Primary School.

Avalon Square features shade trees, essentially neem and mango, whilst a few neem trees are found at Old Kisutu bus station Square, with average girths of 32cm.

From Bibititi to Magomeni, the street strip vegetation (see plate 9) consists mainly of yellow cassia, peacock flower and neem, but also includes Indian date, ashcock, coconut trees and a few almond trees. Girths range from 20 to 135 cm.

Flood plain vegetation (see plate 10) is present with grassland, yellow cassia, peacock flower, neem, etc...The two flood plains of Msimbazi and Jangwani have been described at length in sections 4.2.2.1.

Shade trees and lawns are found at the Dar Es Salaam Institute of Technology, the Lumumba Court, the Fire Brigade HQ, the Jangwani Secondary School and Magomeni KKKT Church. Common trees are neem, Barbados almond, ashcock and a few white mahogany (mkaratusi in Swahili) [*Eucalyptus Robusta*]

From Magomeni to Ubungo, street strip vegetation is dominated by yellow cassia and neem trees. Others, which appear sparsely, include Christmas tree. Girths vary from 20 to over 120 cm.

Shade trees are found at the Baptist Secondary School (Usalama area), on Ubungo Plaza and at Ubungo bus terminal. This vegetation is common on streets within the project's direct area of influence between Magomeni and Shekilango. The land use in this area is basically a mix between residential and commercial, where shade trees have been planted inter alia around pubs and restaurants. Common tree species are those which can provide wide shade such as yellow cassia, neem and peacock flower.

Assorted species of trees grown from seedlings are sold on the LHS, just after Mabibo junction (see plate 11) and at Engen fuel filling station (opposite Ubungo Plaza)

2) MAGOMENI-MOROCCO ROAD SECTION

From Msimbazi to Morocco, a tree grove (see plate 12) is located next to the daladala station, on the LHS, travelling from Magomeni to Morocco. This park consists of trees such as neem, bush fig, yellow cassia and peacock flower.

Street strip vegetation (see plate 13) is found along the sides and middle of the dual lane road. The trees consist mainly of cadia, neem, and yellow cassia, and also include bush fig and Indian date. Tree girths vary from 20 to 260 cm.

As for shade trees, wide varieties such as yellow cassia, neem and peacock flower are the most common along streets, since the road section is a residential/commercial area. Ashcock can also be seen but is mainly meant for landscaping.

River vegetation (see plate 14) is found along Nalung'ombe River, which crosses Kawawa road between Magomeni and Mkwajuni.

3) MSIMBAZI-NYERERE ROAD SECTION

From Msimbazi to Kariakoo, the street strip is sparse, with few trees. Neem and ashcock dominate along this road. Other trees such as bush fig and peacock flower appear sparsely.

As for shade trees, yellow cassia is present in the residential and commercial areas within the project's direct area of influence.

4) UBUNGO-KIMARA ROAD SECTION

From Ubungo to Kimara, shade trees are the main vegetation structure as Kimara is a mixed residential/commercial area (see plate 15). Common trees are those which provide wide shade, such as yellow cassia, neem and peacock flower. Ashcock and Christmas tree are used for landscaping. Other varieties include coconut and mango. Mango trees are used as an orchard tree as well as for shade.

Lawns are present almost throughout the middle of all dual lane roads.

Vetiver grass can be seen between Kimara-Baruti and Kimara-Mwisho (see plate 16). Vetiver grass has been planted on the roadside slope in order to aid slope stabilization.

4.3.3

Socio-Economic Environment

4.3.3.1

Socio-Demographic Characteristics

The immediate DART impact area (DAI) covers 18 Wards in Kinondoni and Ilala Municipalities. The socio-demographic characteristics of the population in this area are hereby presented, based on the 2002 Population and Housing Census and on field survey work concluded in February 2007.

As can be seen in the table below, the total population of the project area was 479,219 in 2002. Given the annual growth rate of 4.3%, it can be estimated that this number is near 590,000 in 2007.

Most of the population in the DAI is within Kinondoni Municipality, where the most populous Wards are Manzese and Kimara.

Population is predominantly young, with 32% of people under the age of 15 years and an age dependency ratio of 51.24%. The fertility rate for Ilala and Kinondoni Municipalities is 6.5%.

Table 4.3.3.1.a
Total Population by Wards

District	Ward	Sub-Wards	Population		
			Male	Female	Total
Ilala	Kivukoni	2	2,596	2,230	4,826
	Kisutu	2	2,978	3,387	6,365
	Mchafukoge	2	3,917	3,747	7,664
	Jangwani	4	8,314	7,408	15,722
	Upanga Mashariki	3	3,418	3,967	7,385
	Upanga Magharibi	3	4,240	5,019	9,259
	Gerezani	1	2,048	2,069	4,117
	Kariakoo	2	4,986	4,322	9,308
Total					64,646
Kinondoni	Magomeni	5	11,488	11,128	22,616
	Mzimuni	4	12,710	12,573	25,283
	Ndugumbi	4	18,679	18,750	37,429
	Makurumula	6	27,493	26,301	53,794
	Manzese	6	34,389	32,477	66,866
	Ubungo	5	22,014	22,325	44,339
	Kimara	1	33,053	24,043	66,288
	Kinondoni	2	10,628	10,861	21,404
	Hanasifu	3	16,040	15,983	32,023
	Mwananyamala	3	21,946	22,585	44,531
Total					414,573
Grand Total					479,219

Source: United Republic of Tanzania 2002 Population and Housing Census.

The immediate DART impact area had a total of almost 102,000 households in 2002, with an average household size of 4.7. In the Ilala section, 27% of the households are female-headed while in Kinondoni 30% are female-headed. (DCC, 2006). The high percentage of female-headed households has implications for poverty reduction since women have lower incomes compared to men, partly because of low educational attainment levels and limited access to other social and economic resources.

The two dominant family structures in the project area are monogamous and polygamous types, basically reflecting the marriage systems that exist in Tanzania. Family structures are also either extended or nuclear. A large proportion of the families in the project area are extended since their members include more than husband, wife and children. These extended families generally include other relatives and children living in households other than their own are very common. This is an accepted cultural practice and norm in the project area and in most other urban centers in Tanzania. These children are often attending schools, helping with household chores or working. Consequently, the large average

household size in the project area is not only a reflection of high fertility rates but also the result of the extended nature of the households.

Survey work in the project impact area identified high ethnic diversity. There is no dominant ethnic group and Tanzanians of all racial or ethnic backgrounds are found. Among these are the indigenous people of the coastal area of Tanzania, the Wazaramo. Other ethnic groups include the Wachaga, Wasukuma, Wapare, Wahaya and many others. Asian ethnic groups (mainly Indian) have clusters of residences concentrated in Upanga and Kisutu Wards. The Jangwani Ward in Ilala district is home to a wide variety of Arabs, Indians and indigenous ethnic groups of Tanzania.

However, it must be pointed out that in spite of this diversity of origins, the majority of people in the DART impact area were born and raised in Tanzania.

Economic activity in the Direct Area of Influence (DAI) is characterized by high levels of informality. Survey work on the project identified very high levels of unemployed or underemployed people, confirming the results of the 2002 Population and Housing Census that concluded that as much as 57% of the economically active population in the Municipalities of Ilala and Kinondoni was unemployed.

Among surveyed occupied people, only 20% had formal employment. 31% operated small and medium businesses, 39% were engaged in some kind of informal commercial activity (i.e. street vendors or similar), 7% were bus operators (drivers or fare chargers) and 3% lived on rental income.

The data collected during the field survey revealed that trade and commerce is the dominant economic activity in the Direct Area of Influence. Medium to large-scale businesses are common in sections of Ilala Municipality, while small to medium-scale businesses of all types occur in the Kinondoni section of the DAI.

Small scale businesses which are dominant include street vendors and small business structures built as front extensions of existing houses. These are common along a significant part of DART Phase I corridors.

The large food markets at Kariakoo and Kisutu are worthy of mention since a substantial number of people are employed there.

The Kivukoni section of the corridor is home to big tourist hotels, government offices, banks, large scale businesses and significant historical sites such as St. Joseph Cathedral, Azania Front and the City Offices.

A 2005 survey by the City Council estimated household annual income at USD 4,650 per year. However, there are huge variations between households in the DART impact area. The Magomeni, Mzimuni, Ndugumbi, Makurumula, as well as parts of Ubungu and

Manzese Wards, are predominantly composed of low-income neighborhoods with slum-like conditions. These areas have no adequate water and sanitation facilities. Kivukoni, Kisutu, Mchafukoge, Upanga East and West and parts of Jangwani Wards are occupied by medium-income level neighborhoods enjoying fair access to infrastructure and social amenities.

The 2005 survey indicated that up to 20% of monthly household expenditure may be spent on transportation alone.

4.3.3.2

Local Urban Structure

Along the Direct Area of Influence, the urban structure can best be understood in terms of a linear description along the corridors of Phase I.

The initial section of the main corridor begins in the Central Business District and has two main segments from an urban structural standpoint: Kivukoni Front and Sokoine Drive until City Council Square, and Morogoro Road until Bibititi Road.

Kivukoni Front and Sokoine Drive establish the limit of CBD's urban fabric and are characterized by the presence of several important public / institutional uses.

Sokoine Drive is a single lane tarmac road that is mainly utilized by public transport to and from the ferry point at Magogoni and carries traffic towards the southern part of the city. Due to its location in the city center, it is characterized by traffic congestion especially during peak hours.

Morogoro Road between City Council Square and the intersection with Bibititi Road is a typical CBD single lane two way street with a narrow right-of-way. Adjacent land-use is mostly multi-storey with no setback of buildings with regards to the sidewalk limits, giving a very high density appearance. Commercial activity is intense on the ground level of the buildings as is pedestrian traffic along the sidewalks. An open square two blocks from Bibititi Road introduces some variety to the dense linear landscape.

Between Bibititi Road intersection and Kimara, the Morogoro Road corridor: major variations.

Along this segment, Morogoro Road is a double lane (2 x 2) avenue that serves the outskirts of the city, linking sub-centers that are located linearly along it. It also serves the upcountry areas of Kibaha, Mlandizi, Chalinze and beyond. Thus, the avenue intercepts very varied urban landscapes, going through densely occupied commercial centers to residential areas and even some unoccupied areas, particularly the Jangwani valley and when approaching Kimara.

Kawawa Road is a double lane tarmac road that functions as a ring road that connects Morogoro and Bagamoyo roads passing through the Kinondoni areas and ending up at its junction with Bagamoyo road. It has public transport running along it that serves either Mwenge – Mtongani or Kawe – Mbagala. It also carries traffic from Tegeta to Kariakoo. Generally, the traffic flow along this road is moderate, but it is poised to increase in the future as the redevelopment of the old and condemned city houses in Kinondoni area is implemented. High-rise apartments will replace the old structures thus increasing population and traffic.

Urban structure along the Kawawa Road branch is a predominantly rectangular urban pattern with medium density mixed use occupation. Irregular urban pattern occurs mostly along the edges of the Sinza River valley which is intercepted perpendicularly. Major highlights are the open spaces near Morogoro Road and at Biafra Square, as well as the Sinza River valley.

Msimbazi street is a single lane two way avenue which is among the most densely congested traffic roads in the city. It extends to the Kariakoo area and receives traffic from several arterial roads. All the buses plying into the Kariakoo market and its surroundings use the street. Hence, it is busy all day as it receives traffic from early in the morning and the same traffic flows out in the evenings. Adjacent land-use is consolidated and high density with very intense commercial activity.

4.3.3.3

Land Use

The predominant land use within the Direct Area of Influence (DAI) is described according to its particular configurations and dominant land uses along the 20.9 Km corridor. As for the DAI characterization, it takes into consideration the area within 300 m each side from the axis of each directly affected road, and the adopted scale was 1:10.000, as shown in the maps on **Annex 7**. It is worth noting that a more detailed land use (1: 2,500) has been produced for the Directly Affected Area (DAA) and is included in **Annex 8**.

To describe its main land use characteristics the area was divided into *five* segments of analysis, according to its functional (main uses) and morphological (main constructive typologies) similarities. The analysis has taken into consideration the following characteristics:

Residential Areas:

- Houses to be demolished
- Medium density (generalized multi storey)
- Medium density (partly single 1 or 2 storey)

- Mixed Use – Medium density
- Mixed use – high density (generalized multi-storey)
- Low density

Public Buildings:

- Public Buildings
- Government Offices
- Religious Site
- Schools
- Public Hospitals
- Police Quarters

Commercial Buildings:

- Commercial Centers
- Commercial Hotels
- Commercial Petrol Stations
- Markets

Industrial Areas:

- Heavy Industry
- Light Industry
- Substation – Tanesco

Open Spaces:

- Cemetery
- Other opens spaces
- Parking areas
- Tower – Ship Control Tower
- Railway Line

The first area is the Central Business District (CBD), where there is a concentration of employment and a mixture of activities that include Institutional Buildings, Religious Sites, Hotels, commerce and also residential areas.

The second area includes Morogoro Road axis, from Bibititi Road to Ubungo, and its main characteristics are the concentration of commercial activities along the main road, and relatively homogeneous residential settlements. In the stretch between Bibititi Rd to Jangwani Valley, there is a concentration of institutional activities along the main road, and within the Valley, there is also a great concentration of residential structures, most of them improvised and in a precarious situation. In the stretch between the entrance to Mabibo and the junction to Nelson Mandela/Sam Nujoma Road, there is a change of features. It consists in the concentration of industries and residential multi-storey buildings spread within large plots, and also an institutional area where the Upcountry Bus Terminal and the Tanzania Bureau of Standards are located.

The third area starts at Ubungo and goes up to Kimara. In this segment, the major land use is a mix of residential, agriculture and livestock, having a low density per hectare. Within this area we can find some commercial activities spread along the main road, and some centers of commercial concentration.

The fourth area includes the Kawawa Road, whose main characteristics are the concentration of commercial activities along the main roads, and the existence of relatively homogeneous residential settlements.

The fifth area comprises the Kariakoo sub-center, located around the Msimbazi corridor. The major use within this area is commercial and residential, and there are few public amenities and open spaces.

4.3.3.4 Utilities

Utility networks and service coverage within the Direct Area of Influence (DAI) was verified with the respective utility companies during ESIA development. The Tanzania Telecommunications Company Ltd. (TTCL) reported that its fixed line network covers 100% of the DAI. The same level of coverage was reported by the Tanzania Electricity Supply Company Ltd. (TANESCO).

With regard to water and sewerage networks, the Dar Es Salaam Water & Sewerage Authority (DAWASA) reported full water supply coverage within the DAI. However, only partial coverage of sewer collection services exists. The current situation of DAWASA networks can be summarized as follows:

- i. Msimbazi Road (Kariakoo area) – 100% Water and Sewerage
- ii. Morogoro Road
 - City Hall – Fire - 100% - Water & Sewerage

- Fire – Manzese – 100% - Water
- Manzese – Ubungo – 100% - Water & Sewerage
- Ubungo – Kimara – 100% - Water

iii. Kivukoni Front – 100% Water & Sewerage

iv. Kawawa Road - 100% Water

4.3.3.5

Historical, Cultural and Archeological Features

No historical or cultural buildings will be directly affected by the project. However, some significant architectural and religious landmarks lie within the Direct Area of Influence and are worthy of mention. These include:

- The State House on the right hand side from the ferry
- Vice President House
- Ministry of Home Affairs and Mapping Division
- Bureau of Statistics
- Commercial High Court
- Azania Front Church
- UN Information Center
- The German buildings around the area that today houses many government ministries and institutions eg, the present ‘Commercial Court’ at the junction of Sokoine Drive and Luthuli roads.
- The White Fathers Building (adjacent to the former headquarters of Ministry of Water and Energy)
- The present St. Joseph’s Secondary School
- The St. Joseph’s Roman Catholic Cathedral
- The Old Boma Building
- The City Hall and the adjacent building now housing the headquarters of the Ilala Municipal Council
- Kariakoo Primary Court
- The Fire Brigade Office
- The Hindu Temples on Kisutu Street
- The Hindu temple opposite the Lumumba/Morogoro junction

There are no records of archeological remains in the vicinity of DART’s Phase I alignments.

4.3.3.6

Social Organizations

Communities in the DART corridor are organized in diverse ways, based on ethnic, professional, gender, political, economic and religious criteria. There are both formal and informal associations or social groupings that tend to bring social cohesion. However given the great deal of diversity in terms of interests and needs, the community cohesion is not strong within the impact area.

The existing loose social groupings that bind the communities along the DART immediate impact area have created social networks to address specific issues of interest. Among these social groups include women's groups formed to address issues around economic well being of women in specific sub-wards. Religious groups are formed around gender, age and belief systems.

Most of the peoples to be directly affected by the project have no formal social organizations. However some social groups share common interests and concerns and thus can easily forge strong social bonds when their businesses are under threat.

Also relevant is the strong religious social cohesion, especially when these groups feel they are under a planned external threat but these same strong group cohesions are then also the source of social conflict and disintegration in the wider community.

In the past decade political affiliations have also been the basis for community cohesion but at the same time fragmentation. During the one party rule there were limited political differences but within the multiparty system there are strong political party affiliations. This situation, while increasing community cohesion, can at the same time create some disunity.

Economic issues also are source of social cohesion and integration but at the same time source of conflicts.

For example some groups have formed active social organizations precisely when they were under external threat. The association of small business holders at Ubungo Maziwa (KINGWUMA) is a good example of such an organization. This association was formed to fight an eviction order by the municipal council to give their business premises to bus owners for ticket offices. The case is still pending in the court of law. The Association of Seedling Traders at Ubungo (UWAMU) was formed for economic purposes. The Association of Kagera Open Market Traders was formed to resolved conflict over land use with the neighbouring communities.

The Youth Empowerment Society civil organization is a member of the Association of Non-Governmental Organization (TANGO) in Tanzania.

Outside of the formal social organizations there exist an extensive informal social network of relationships in the communities based on ethnic identities (support groups in times of hardships and celebrations), professional associations, economic groups, and religious and political organizations.

Although these informal social associations and networks may not have a direct bearing in the implementation of DART they are none the less an important social organization which could make the mobilization and sensitisation of people about the project easier and create a sense of local ownership and identification with the project. In this way it might be easy to overcome resentment created from the negative impacts.

4.4 Directly Affected Area

4.4.1 Land Use

A detailed land use map of the directly affected area (DAA) is presented in **Annex 8**. This land use map includes not only properties abutting on the corridor right of way, but also uses on the right of way itself.

Regarding abutting properties, the land use specification considers two sets of variables:

- Types of land use
- Predominant height of buildings

The field survey conducted was based on the use of aerial photos dated from 2002 and cartographic survey dated from 1992. The survey was done on maps scaled to 1:2500.

The analysis of the directly affected area considers only the use of the frontal properties to the corridor and terminals, and the land use classification has taken into consideration the following characteristics:

Abutting Properties (at ground floor):

- Residential properties (at ground floor)
- Commercial and Services Activity Types:
 - (1) Restaurant / bar / food & leisure/hotel
 - (2) Vehicle related services (excluding petrol stations)
 - (3) Petrol stations
 - (4) Other retail or services (including banks and financial institutions and markets)

- (5) Religious buildings
- (6) Public / Institutional buildings (including schools)
- (7) Industrial
- (8) Other (hospitals, fire station, etc)

The upper floors were also classified by their predominant use, considering only if they were residential or commercial.

The buildings were also classified by height, using the following classification:

- 1 or 2 storey buildings
- 3 or 4 storey buildings
- 5 or more storey buildings

Regarding uses inside the right of way, several aspects have been met. Current bus stops have been identified, as well as public areas occupied by bars and restaurants and other row areas occupied by abducting commerce. Areas occupied by street vendors and by taxi spots, daladala parking, construction trucks parking areas and others have also been clearly located in the land use map. The uses inside the right-of-way (ROW) were also classified, and they were listed according to the following descriptions:

- Area occupied by bars and restaurants
- Other ROW areas occupied by abutting commerce
- ROW areas occupied by street vendors (portable)
- ROW areas occupied by fixed / authorized street vendors or equivalent
- Daladala stops
- Daladala parking areas
- Taxi stops
- Truck parking areas
- Other parking areas (indicate use)
- Other (indicate use)

In order to better analyze the present land use along the corridor, it was divided into 9 segments, according to its particular characteristics. The division is the same used at the Direct Area of Influence Analysis.

Table 4.4.1.a
Stretch

Stretch	Streets/Roads
1	Kivukoni Front/Sokoine Drive
2	Morogoro Road – from City Council to Bibititi Rd
3	Morogoro Rd – from Bibititi Rd to Jagwani Valley
4	Morogoro Rd – from Jangwani Valley to Magomeni
5	Morogoro Rd – from Magomeni to the Entrance to Mabibo
6	Morogoro Rd – from the Entrance to Mabibo to Ubungo
7	Morogoro Rd – from Ubungo to Kimara
8	Kawawa Rd
9	Msimbazi Street

Figure 4.4.1.1
Stretches for Analysis

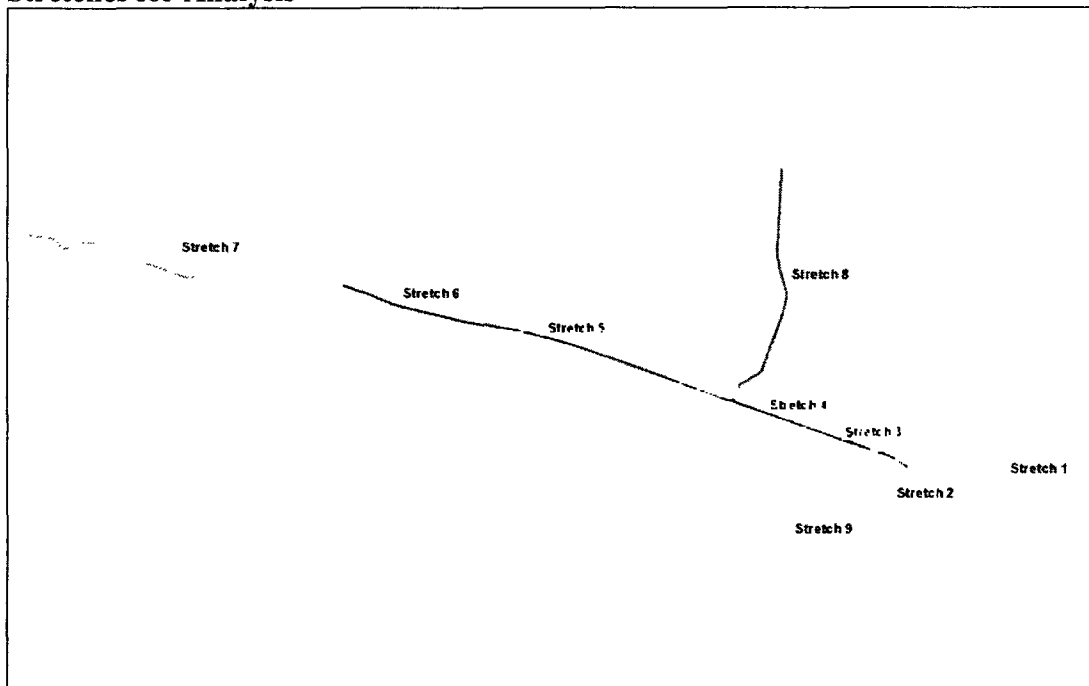

Stretch 1

The Fish Market, and the ferry to Kigamboni are located at the beginning of the corridor. A control tower is also being constructed next to the open area that will be connected to the Kivukoni Terminal construction.

The first characteristic of the main stretch is the predominance of major public and institutional buildings. The area also includes important hotels, banks, churches and the Sea Ferry Terminal, in front of the City Hall.

There are few institutional buildings along the sea front and the area is used predominantly by food vendors, and we can find also some ambulatory small businesses like newspaper vendors or shoe-shines. This open area is also used for car parking, and attending to institutions' and the hotels' needs.

The most significant points or buildings at this stretch are:

- Ferry to Kigamboni
- Fish Market
- Control Tower
- Kilimanjaro Hotel
- Azania Front – Lutheran Church
- Saint Joseph's Cathedral
- Sea Ferry Terminal and the DSM Marine Institute

Stretch 2

This stretch begins at the City Hall, and goes up to Bibititi Mohammed Road, and is characterized mainly by the high density of medium and tall buildings (more than 5 floors). This is a mixed area, and, although there are many buildings with small shops on the ground floor and residences at the upper floors, there are also entirely commercial buildings. There are also petrol stations, which will be partially affected by the implementation of the corridor.

The most significant points or buildings at this stretch are:

- Parking Area in front of the City Hall
- City Hall
- United Nations Buildings at Samora Avenue
- PPF Houses

Stretch 3

The main characteristics of the third stretch are the institutional buildings facing the corridor, with very scarce commercial sites placed directly on the road. There are two petrol stations at this area, and three important intersections, with Lumumba Street, Msimbazi Street (which is also part of the system) and United Nations Road.

The most significant points or buildings at this stretch are:

- College of Business Education
- Dar es Salaam Institute of Technology
- Hindu Temple
- Lumumba Court
- Fire Station

Stretch 4

This area starts at the Jangwani Valley, and ends at the intersection of Morogoro Rd and Kawawa Rd (which is also part of the system). The valley is occupied mostly by houses at its marginal areas, but there is also an inactive construction company at its left edge, and some fixed vendors, selling construction materials from improvised sites.

The Morogoro Road, is not at the same level as the houses and shops that face the corridor (it is sometimes lower, sometimes higher), and there is no direct access to the buildings from the road. To gain access to the buildings, it is necessary to take side streets, or at some points even stairs for pedestrians.

At the junction with Kawawa Rd, there are two important religious buildings, and other major commercial areas facing the road.

The most significant points or buildings at this stretch are:

- Jangwany Valley
- Magomeni Mviringo Lutheran Church
- Tanzania Islamic Center

Stretch 5

This stretch begins at the junction with Kawawa Road, and goes up to the entrance to Mabibo. The buildings are generally one or two stories, with only a few buildings higher than this. The main characteristic of this segment is the great concentration of commercial areas facing directly onto the corridor. The great majority of these are related to food and pedestrian activities, but at some points it is possible to find a concentration of vehicle related activities, especially garages for maintenance, that will be affected directly by the changes resulting from the construction of the corridor. There are two significant market areas on this stretch, the Magomeni Market, and the Manzese Market:

- Magomeni Market – This market is located near the junction of Morogoro Rd and Kawawa Rd, and is divided into three sections: The first one, in the front area, in which vendors of clothes and domestic utilities are located. The second section

contains the vendors of fruit, grain and poultry. At the third one, at the back, consists mainly of food, meat, and other domestic product vendors.

- Manzese Market – This Market is located at the Manzese area, and contains mainly vendors of grain, fruit and poultry. There are also butcheries, food vendors, and at its edges, some vendors of domestic products, small objects and clothes.

The most significant points or buildings at this stretch are:

- Magomeni Health Center
- Kinondoni Municipal Council
- Dar Es Salaam Baptist Secondary School
- Magomeni Market
- Manzese Market

Stretch 6

This stretch begins at the entrance to Mabibo and is characterized by sparse constructions and the large industrial buildings placed along the road. The residential area comprises few buildings, 3 to 4 stories, on the right side, and the industrial area which occupies large areas to the left side of the road.

There are also some permanent vegetable street vendors placed in front of the Urafiki Textile Company, and some small commercial and street vendors along both sides of the path.

There are two significant market areas at this stretch, the Urafiki Market, and the Shekilango Market:

- Urafiki Market – This market is composed mainly of clothes and shoes vendors, and other small domestic products. There is also an area for food, but it is used mainly by local workers.
- Shekilango Market - This market is located at Shekilango road, behind the ORYX Petrol Station. There are mainly fruit, grain and food vendors there. At the back, there are some bars, and tailor shops.

The area also has a big commercial center, the Ubungo Plaza, and the Upcountry Bus Terminal, where one Bus Depot and one important DART Terminal will be constructed.

The most significant points or buildings at this stretch are:

- Urafiki Market
- Shekilango Market
- Tanzania-China Friendship Textile Co Ltd (Urafiki Textile Company Ltd)

- Millennium Business Park
- YDK Holdings Tanzania
- Congas
- Ubungo NHC Flats
- Urafiki Residential Flats
- Ubungo Plaza – Business Center
- Ubungo Upcountry Terminal
- Tanzania Bureau of Standards

Stretch 7

This stretch begins at the Nelson Mandela/Sam Nujoma Rd Junction, and goes up to Kimara. At this point, the general character of usage changes as the area contains mostly one storey residential buildings and sparse commerce along the road. This commerce is not accessible directly from the road (only some petrol stations and few other services), and to gain access to the buildings it is necessary to take side streets

This area is home to a significant number of ambulatory street vendors, most of them concentrated next to bus stops and to commercial areas.

The most significant points or buildings on this stretch are:

- TANESCO Power Station and Offices
- Daladala Terminal
- Institutional Buildings close to the junction with Nelson Mandela/Sam Nujoma

Stretch 8

This stretch comprises the Kawawa Road, starting from Morogoro Junction to Ali Hassan/New Bagamoyo Rd junction. The main general characteristics of this segment are the concentration of small commercial sites close to the road, and the existence of a few religious centers.

There is valley crossing this road (the Sinza River Valley), and, at this point, there is a great concentration of residential buildings, but, most of them, do not directly face the road.

There are also some open areas, one nearby the junction to Morogoro, that is used as a recreation park, and another one at Biafra, in front of the Biafra School Building, that is also used by the population for leisure activities.

The most significant points or buildings on this stretch are:

- Magomeni Health Center
- Magomeni Roman Catholic Church
- Open University of Tanzania
- Daladala Terminal

Stretch 9

The Msimbazi Street is today a very congested way, especially because of the concentration of daladala traffic. There are many tall buildings, some of them under construction, and there is a great concentration of commercial activities, both on the ground and upper floors. This stretch is mainly characterized by the sales of spare parts and electronics articles, but there are also food vendors, and it is possible to find many street vendors, fixed or ambulatory, along the street. It is also near the Kariakoo Market, which will not be directly affected, but will have an important influence the dynamics of this area.

At the end of this stretch, there is a residential area where the Kariakoo Terminal will be placed, and the railway crossing.

Near the railway, there are two areas prepared to house the recently displaced street vendors: one of them was not completely occupied, and most of the kiosks are empty. Since it is an area where there is no pedestrian flow; the other one, closer to the street, will be occupied by more than twenty small food vendors, and other activities, most of them related to car maintenance, spare parts, or activities related to carpentry.

The most significant points or buildings at this stretch are:

- Railway Crossing
- Scandinavian Bus Depot (after the Railway)

General comments about the uses inside the Right-of-Way

In general, the street vendors are concentrated nearby daladala stops, or along the commercial areas. Most of them are shoe-shines and newspaper vendors, but at some points it is possible to find people selling fruit, or small items.

We can also find some kiosks, and, most of the times, they sell phone cards, food, and some small items.

It was noticed also, that many small shops, mainly the furniture shops, use the right of way to display their products, since they have no space inside their buildings. Bars and

restaurants also do the same, using the right-of-way sometimes to place tables, and sometimes even to prepare food.

The right-of-way is extensively used in relation to the Parking areas. There are many taxi ranks, and truck services. The maintenance garages also use this area to park and fix vehicles.

4.4.2 Project Affected People

Based on socio-economic survey work conducted for resettlement planning purposes (to be fully documented in the Resettlement Action Plans for Phase I – Part A and Phase I – Part B), a typology of project affected peoples has been established. This includes both people and businesses to be affected through expropriation (which may be total or partial), and people and businesses that will be displaced without being subject to expropriation, either because they informally occupy part of the corridor rights-of-way, or because they are employed or own businesses on properties abutting on the corridors which may become economically unfeasible due to the project's impacts.

The table below presents a summary of properties to be totally or partially expropriated in Part A and Part B. As can be noted, resettlement needs are far more significant in the case of Part B. Nonetheless, total resettlement required by the project is relatively limited and will affect no more than 78 families and about 50 businesses.

**Table 4.4.2.a
Type of Expropriated Property**

Type of Expropriated Property	Phase I – Part A	Phase I – Part B
Residences to be totally affected	9	69
Residences to be partially affected	5	0
Commercial establishments affected within residences	11	21
Totally affected independent commercial establishments	7	21
Partially affected independent commercial establishments	68	2
Other affected buildings	12	1
TOTAL AFFECTED PROPERTIES	112	114

Based on the expropriation needs described above and on the results of survey work, the following is the typology of project affected peoples, including those affected directly by expropriation and those that will be displaced for other reasons:

- Non-occupant owner of property that will be totally affected.
- Non-occupant owner of property that will be partially affected.
- Owner-occupiers of residencies that will need to resettle.
- Owner-occupiers of residences that will be partially affected but may reinstall in same plot.
- Owners of businesses in own premises that will need to relocate.
- Owners of businesses in own premises that will be able to reinstall in the same plot.
- Owners of businesses occupying rented premises that will relocate.
- Owners of businesses in rented property that will be able to reinstall in the same plot.
- Commercial tenants and/or concessionaires at Ubungo terminal, which include approximately 80 establishments of various that will be accommodated in the new layout.
- Residential tenants that will relocate.
- Residential tenants that will reinstall in the same plot.
- Employees in workers housing that will need to relocate at Kariakoo Terminal.
- Illegal occupants of workers housing that will need to relocate at Kariakoo terminal.
- Owners of businesses in either own or rented premises that will suffer provisional loss of business or closure during construction.
- Authorized non-transient street vendors, which include mostly owners of street kiosks as well as people selling tree seedlings and ornamental plants in the right-of-way near Ubungo and at Kimara.
- Daily transient street vendors, which are today relatively sparse but still remain in various segments of the corridors, mainly in Morogoro Road.
- Owners of businesses to be indirectly affected by the project, including businesses that make informal use of the right-of-way in ways that will not continue to be feasible once the corridor is implemented, such as bars and restaurants that put chairs and tables on the street, furniture stores that display their products, and a car dealer that parks vehicles for sale in the right-of-way.
- Other informal users of the public right-of-way that will need to relocate, including fixed parking areas occupied by taxi spots, daladalas and even trucks which are hired by the population for assistance in construction activities.
- Employees of businesses that will be dismissed or placed in stand-by because of provisional closure or loss of business during construction.
- Employees of businesses to be relocated.

The Land Use Map of the Direct Area of Influence (DAA) included in **Annex 8** indicates in an approximate manner the location of informal uses of the corridor rights-of-way.

4.4.3

Current Corridor Traffic

Current corridor traffic levels can be analyzed from the observations made during the many site visits done during project planning phases, as well as on the basis of the results of field surveys conducted in 2005, when traffic modeling and demand analysis was performed.

Traffic flow characteristics vary significantly along the various segments of Phase I corridors. At the Kivukoni area, a great concentration of pedestrians can be observed, mostly at the Ferry, where a daladala terminal which is an important transfer point for public transportation is currently located.

Along the water front and the beginning of Morogoro Road, traffic counts showed a great concentration of cars (around 70%) and also a considerable percentage of daladalas (around 20%), although comparing to the entire corridor, the number of total vehicles circulating in this segment is relatively small.

From Bibititi Road to Ubungo, current characteristics of traffic vary significantly, although the total number vehicles circulating is relatively homogeneous. The number of daladalas is higher between Msimbazi Street and Magomeni Mapipa, where daladalas have a higher share of total traffic than private vehicles (39% of daladalas, 35% of private cars, 19% taxis).

Traffic counts indicate that the point of highest traffic concentration is located around the Ubungo Region, near the crossing with Nelson Mandela / Sam Sujoma Road. At this point, around 42% of traffic is composed of private vehicles and 33% by daladalas. In this segment, the bus flow is higher than in other segments of the corridor due to the presence of the Upcountry Bus Terminal.

From Ubungo to Kimara, the percentage of daladalas in total traffic is considerably reduced, whereas the number of trucks and private cars circulating increases.

At Kawawa Rd a great concentration of daladalas (40% of total traffic) and private cars (34%) is observed. Trucks represent 4.5% of total traffic, which is a significant percentage in comparison to other segments.

At Msimbazi Street a very large concentration of daladalas circulates. Near the railway, an important terminal is operating in an improvised way along the street. This is a conflict point, and there is no infrastructure in this area to support the traffic flow generated by this operation (both of pedestrians and public transportation).

At intersections traffic was counted on each directional flow. Intersections were found to be the main traffic bottlenecks along the corridor, especially at peak hours. One important reason for this are the four-phase stop lights, which leave little time of open signal for main corridor flows. Another reason is the fact that many intersections are operated by traffic policemen and green time varies according to personal judgment.

With regard to pedestrian flow concentration, significant peak hour concentrations occur mostly in the Ubungo region and at Kivukoni, near the Ferry. Other points of considerable concentration are Magomeni and Tip Top.

Bicycle traffic is more intense between Magomeni and Urafiki, and along Kawawa Road.

4.4.4

Corridor Utilities Survey

This survey is necessary to identify the existing location of the utilities and the extent of interruption with the DART corridor.

Utilities in the proposed DART Phase I corridors include telephone landlines owned by Tanzania Telecommunication Company Ltd (TTCL), electric power lines owned by Tanzania Electricity Supply Company Ltd (TANESCO) and water supply and sewer lines owned by Dar Es Salaam Water and Sewerage Authority (DAWASA).

Prior to mapping these utilities, data in the form of *as-built* maps from the agencies and plans prepared by the contractors responsible for rehabilitation of the roads in the recently concluded Dar es Salaam Road Improvement Project – DRIP (M/S Konoike Construction Co. Ltd. of Japan and Skamphil Colas Ltd. of Denmark) were collected.

Besides, the topographical survey conducted by the Consultant (Logit/Inter-consult) for DART corridor involved covering all utility services and associated installations.

As a check, the *as-built* drawings collected are being compared with the topographical maps prepared by the consultant for DART corridor to confirm existence and actual location.

Due to lack of precision in the location of utilities on the maps from the Utility companies, topographical maps prepared by the consultant were sent to them for their confirmation, also complemented by joint site visits between the consultant and the utility companies.

After confirmation of the location the consultant shall then superimpose the proposed DART corridor on the topographical maps with the utilities to identify those likely to be relocated (relocation will be carried out by the utility companies). Cost estimates for relocating the affected utilities shall be prepared by the companies. A program for relocation shall be prepared and mutually agreed upon.

Whereas detailed definition of utility relocation needs has not been established at the project's current stage of engineering development, it is possible to state that the most affected utility network will be the electricity grid. Significant relocation of aerial electricity distribution lines as well as street lighting poles will be necessary.

4.4.5 Corridor Vegetation

The vegetation of the road corridor (within the limit of construction) is dominated by street trees and shade trees in the outskirts of the city. The type and quantity of trees to be affected on each main segment of DART Phase I is described below.

Kigamboni Ferry to Ubungo Station

The vegetation that will be affected along this segment are mostly those located at the proposed stations and terminal (adjacent to Shaurimoyo). The Kigamboni Ferry - Ubungo Road section is dominated by yellow cassia trees (59%), followed by neem trees (approximately 14%). Other species to be affected include ashock, B almond, coconut, Indian date, Tamarindus indica and mango trees. It is worth to note that of the affected tree species, yellow cassia give the widest shade after neem tree.

In total there are 768 trees which will be affected in this segment. The majority of the trees (about 60%) have girths between 51 and 100 cm. Approximately 28% have girths under 50% and almost 10% have girths in the 101 cm. to 150 cm. range.

Ubungo Station to Kimara Mwisho

The road section between Ubungo and Kimara has the lowest number of trees along the road which will be affected by implementation of the project. This is simply because the provision for road reserve made during upgrading of the road section in question a few years ago is wide to the extent that implementation of DART will only affect where the feeder exchange and terminal will be constructed at Kimara Mwisho.

As discussed earlier, trees located at the middle of the existing dual lane road have less than 20 cm in girth.

Trees which will be affected where the exchange and terminal will be constructed are dominated by coconut, followed by Christmas tree species. Other trees are yellow cassia, governor's plum (mchongoma), neem, peacock flower, and jack tree (mfenesi) [Artocarpus heterophyllus].

It is estimated that 66 trees will be affected at the proposed terminal and station. Coconut trees account for 47% of all the trees, followed by Christmas tree which represents about 30%. Other affected species include G plum, jack tree, peacock flower and Y cassia.

Most of the trees (80%), have girths between 51 and 100 cm. Most of the remaining trees have girths under 50 cm.

Msimbazi Road Branch

In this road section, a total of 49 trees, most of them (47%) of the neem species. Ashock is also common (39%). Other species to be affected include bush fig, cadl, peacock flower, umbrella and Y cassia. The majority of the trees (69%) have their girths between 20 and 50 cm. while the remainder have girths between 51 cm. and 100 cm.

Kawawa Road Branch

Vegetation that will be affected in the Kawawa Road branch (Magomeni – Morocco) are mostly street trees (especially where stations will be constructed) and to a small extent, lawns. A total of approximately 300 trees, of bush fig, cadl, Indian date, neem, and yellow cassia species, with girths varying from 20 cm. to 260 cm (average girths 54 cm) will be affected. Most of the trees (58%) which will be affected have their girths ranging from 51 to 100 cm. and roughly 40% have girths under 50 cm. The dominant species are neem trees (57%), followed by cadl (32%) and cassia (10%).

It is worth to note that of the five tree species, neem trees give the widest canopy size, followed by yellow cassia. In addition, experience has shown that neem tree is the fastest growing of the five species.

5.0 Legal and Institutional Framework

5.1 Institutional Framework

5.1.1 Environmental Planning and Permitting

The institutional set-up for environmental management from national level to village level includes:

- National Environmental Advisory Committee;
- Minister responsible for Environment;
- Director of Environment (DOE);
- National Environmental Management Council (NEMC);
- Sectoral Ministries
- Regional Secretariats;
- Local Government Authorities [City, Municipal, District, and Town Councils; Township; Hamlet (Kitongoji); Ward; Street (Mtaa); and Village].

The DOE and the NEMC are the main regulatory bodies for environmental management in Tanzania. However, other sectoral ministries and agencies / institutions, have an important role in implementing environmental policy objectives. The environmental management functions of each institution are as outlined in the Environmental Management Act of 2004.

National Environment Advisory Committee

The National Environment Advisory Committee is the top advisory body to the Minister or any Sector Ministry on any matter concerning the environment. It is composed of members from various fields of environmental management in the public and private sectors and civil society. The members are specified in the FIRST SCHEDULE of the Environment Management Act of 2004. The Permanent Secretary chairs the body. Other members include:

- Director of Environment – Secretary
- Director General of NEMC
- Commissioners for Minerals, and Energy
- Representatives from the Attorney General’s Office and the Ministry of Community Development,
- Directors of Sector Ministries, including Local Government, Disaster Management, Roads, Human Settlement, Ministry of Health (Preventive Services) etc.
- Chief Government Chemist

- Representatives from Higher Education Institutions, Civil Society Organizations and the private sector.

Minister responsible for Environment

The Minister has the overall responsibility for environmental matters, including policy articulation for promotion, protection and sustainable management of the environment in the country. Other duties include issuing policy guidelines to Sector Ministries, Government Departments, NEMC, National Environment Advisory Committee, City, and Municipal, District or Town Environment Management Committees, agencies or any other public or private institutions

Director of Environment

Responsible for heading the office of the Director of Environment and is responsible for coordination and monitoring / assessment of various environmental activities and giving early warning on impending environmental emergencies. The director is responsible for advising the Government on policy / legislative matters and international agreements / conventions.

National Environment Management Council

This body has power to take legal action and may have action taken against it; it may also hold, purchase, acquire and dispose of movable and immovable property. It is responsible for undertaking enforcement, compliance, review and monitoring of environmental impact assessment (EIA). It prepares and submits bi-annual reports on the implementation of the provisions laid down in the National Environment Management Act of 2004, and on how it has fulfilled the objectives and purpose for which it has been established.

The Director General appointed by the President heads the Council and the Board of Directors, which consists of:

- Chairperson appointed by the President;
- Director General –as the Secretary to the Council
- Director of Environment
- Seven members appointed by the Minister

Sector Ministries

The Sector Environment Sections in Sector Ministries are responsible for ensuring: compliance by the Sector Ministry with the requirements of the Act and ensuring all environmental matters are implemented and reports to the Director of Environment. They

are also responsible for liaising with the Director of Environment and NEMC on matters involving environment.

The Sector Environment Coordinator, who is appointed from within the Sector Ministry heads the Sector Environment Section. The Coordinator is responsible for:

- Coordination of all activities and performance of the functions relating to environment
- Prevention and control of any activity likely to cause or lead to environmental degradation;
- Report on the implementation and enforcement of environmental provisions of laws falling under the jurisdiction of the sector
- The Sector Environment Coordinator submits to the Director of Environment:
- Bi-annual reports on the state of the environment, including other reports as may be required by the Director of Environment;
- Review environmental law under the Ministry and the extent of its implementation

Regional Secretariat

It is responsible for environmental coordination of all advice on environmental management in the regions and liaises with the Director and the Director General on implementation and enforcement of the Environment Act.

A Regional Environment Management Expert appointed by the Minister responsible for Regional Administration heads the secretariat. The Regional Environment Management Expert is responsible for advising the local authorities on matters relating to the implementation and enforcement of the Environment Act. The Expert links the region with the Director of Environment and Director General.

Local Government Authorities

The local government environmental management officers are appointed by each City, Municipal, District and Town Council as follows:

- City Environmental Management Officer;
- Municipal Environmental Management Officer;
- District Environmental Management Officer;
- Town Environmental Management Officer

The local government environmental management officers are responsible inter alia for:

- Ensuring enforcement of the Environment Act;
- Advising the environment management committees;

- Promoting environmental awareness;
- Gathering and managing information on environment and utilization of natural resources;
- Preparing periodic reports on the state of the environment;
- Monitoring the preparation, review and approval of environmental impact assessment for local investment;
- Reviewing by-laws on environmental management and on sector-specific activities related to environment;
- Reporting to the Director of Environment and the Director General on implementation of the Act.

Standing Committees

The following standing committees operate at district and urban authorities level:

- Standing Committee on Urban Planning and Environment –established under Sub-section (1) Section 42 of the Local Government (Urban Authorities) Act, 1982;
- Standing Committee on Economic Affairs, Works and Environment – established Sub-section (1) of 74 of the Local Government (District Authorities) Act, 1982

Under each Standing Committee there is an Environment Management Committee as follows:

- City Environment Management Committee;
- Municipal Environment Management Committee;
- District Environment Management Committee;

The City, Municipal and District Environment Management Committees are responsible for functions provided under Sub-section (1) and (2) of Section 55 of the Local Government (Urban Authorities) Act, 1982 and Sub-sections (1) and (2) of Section 118 of the Local Government (District Authorities) Act, 1982.

They perform functions as prescribed by the Environment Act and/or as may be assigned by the Minister by notice published in the Gazette carry out directives given by the Minister in relation to the promotion and enhancement of sustainable management of the environment.

For the Township level the relevant bodies are:

- Standing Committee of Economic Affairs, Works and Environment – established under Sub-section (1) of Section 96 of the Local Government (District Authorities) Act, 1982

- Special Committee – established under Section 107 of the Local Government (District Authorities) Act, 1982;
- Ward Development Committee – established under Sub-section (1) of Section 31 of the Local Government (District Authorities) Act, 1982

The committees are responsible for:

- Proper management of the environment in their areas of jurisdiction
- Performing duties as assigned by the Minister of Councils
- Carrying out directives given by the Minister to promote and enhance sustainable management of the environment and as provided under the Local Government;
- Performing any functions as provided by the Local Government (District) Authorities Act, 1982.

For Villages there is the Village Development Committee responsible for proper management of the environment and other functions as provided in paragraphs (a), (b), (c) and (d) of sub-section (1) of Section 38 of the Environment Management Act, 2004.

There is an Environmental Management Officer for Townships, Wards, Villages, Kitongoji (Sub-village) and Mtaa (Street) as follows:

- Township Environmental Management Officer;
- Ward Environment Management Officer;
- Village Environmental Management Officer;
- Kitongoji Environmental Management Officer;
- Mtaa Environmental Management Officer

The Environmental Management Officers are responsible for coordination of all functions and activities for the protection of the environment within their areas.

5.1.2

Urban Planning

The Urban Planning process in Tanzania is guided by the Town and Country Planning Ordinance of 1956 and involves - inter alia - the preparation of general planning schemes, detailed planning schemes and urban development control based on the approved plans.

Generally, all the local authorities - Town, Municipal and City Councils - as stipulated in the above law, prepare all the planning proposals. The plans are then presented before the Urban and Environmental Councils where they are deliberated upon and approved/amended before being submitted to the Directorate of Urban Planning and Human Settlements for final approval. The original plans are deposited there. Copies are returned to the Councils for implementation.

The City Council of Dar Es Salaam and the three municipalities of Temeke, Ilala and Kinondoni were established under the Local Government (Urban Authorities) Act of 1982 (Act Number 8 of 1982) which provides for the establishment, composition, functioning and legislative powers of the urban based local government authorities (urban councils) in Tanzania. Section 42 of Act number 8 of 1982 provides for the establishment of Urban Authorities Committees in charge of finance and administration, which includes urban planning and environmental protection.

5.1.3

Transportation Planning and Infrastructure Implementation and Operation

The Tanzania National Roads Agency (TANROADS) was established on 1st July 2000 under the Executive Agencies Act, No.30 of 1997. It is responsible for the day to day managements of trunk and regional roads network totaling about 30,000 km of which the City main arteries are included as trunk roads. The sections falling within the city boundaries are managed by the TANROADS Regional Manager for Dar Es Salaam.

5.1.4

Expropriation and Resettlement

Land Acquisition Act N^o 47 of 1967, Land Act N^o 4 of 1999 and Village Land Act N^o 5 of 1999, establish among other aspects, the conditions under which expropriation and resettlement for public infrastructure projects will take place.

As applicable to the DART project, expropriation under these legal instruments will be a responsibility of the Dar Es Salaam City Council that must proceed with valuation of properties eligible for compensation and must establish the value of complementary allowances for affected peoples, making the necessary budgetary allocations.

Property valuation must be carried out by certified valuers that must be accompanied by municipal valuers. The city's Chief Valuer is responsible for approving the Property Valuation and Complementary Allowance Schedule.

The City Council will monitor and supervise land acquisition and resettlement activities as deemed pertinent. Council responsibilities include planning, coordination of field implementation, financial control, information exchange, inter-agency liaison and day-to-day monitoring.

5.2 Legal Framework

5.2.1 Environmental Planning and Permitting

The Environmental Management Act No 20, which was established in 2004 governs environmental management issues including Environmental Impact Assessment (EIA) requirements in the country.

The Act stipulates that any developer of a project to which EIA is required to made by the law shall undertake at his own cost EIA before commencing the project.

The Act also defines environmental management tools of general scope to facilitate consistent policing and enforcement. Examples include:

- Environmental Impact assessment (EIA), which helps to identify and minimize possible impacts from a proposed development before commencement;
- Environmental Monitoring for compliance with set standards;
- Environmental auditing, which evaluates how well environmental organizations, management and equipment are working.

Water Utilization and Control Act of 1974

The water utilization and control act of 1974 (amended by act No. 10 of 1981 and Act of 1997) regulates management of water resource. It vests ownership of all water in the United Republic of Tanzania and requires every person who seeks to divert, dam, store or abstract the water to seek permit (Water Right Grant) from the Government.

The act:

- Controls the discharge of effluents or liquid wastes into water bodies
- The acts forbids pollution of water supplies.
- Gives powers to urban water authorities to make rules regarding surface and ground water pollution
- Prohibits discharge of certain substances into public sewers

Water Quality Standards

The water quality standards have been established under the Water Utilization (Control and Regulation) Amendment Act No. 10 of 1981. The standards deal with effluent discharge and receiving waters. Also, there are Tanzania Temporary Standard for domestic Water,

which is comprised of also adopted the WHO standards and Tanzania Standards for Rural Water Supply

Local Government (District and Urban Authorities) Acts of 1982

This enables local authorities to enact by-laws regarding soil protection, natural resource exploitation etc.

The Forest Act of 2002

The Act enables local government authorities, including village governments to have power over some forests that are within their areas of jurisdiction.

5.2.2

Urban Planning and Zoning

As far as the direct area of influence is concerned, the principal legislation is the Town and Country Planning Ordinance, cap.378. A number of other laws support this ordinance, including:

- The Public Recreation Grounds Ordinance cap 320
- The Township Building Rules cap 101
- The Land Acquisition Act No 47 of 1967
- The National Investment Act No.10 of 1990
- The National Land use Planning Commission Act No.3 of 1984
- The Local Government (Urban Authorities) Act No. 8 of 1982
- The Land Act No. 4 of 1999

Local authorities are the most important actors in implementation of urban development, as mandated by the Local Government (Urban Authorities) Act No 8 of 1982. Other stakeholder institutions in the planning process include: Ward leadership and Mtaa leadership, utility companies like the Tanzania Telecommunication Company (TTCL), Dar Es Salaam Water and sanitation Company (DAWASCO), The Tanzania Roads Agency (TANROADS), The Municipal Councils of Ilala and Kinondoni and the Ministry of Lands and Human Settlements Development.

The Dar Es Salaam City Master Plan of 1979, introduced a Zoning Plan for the city's development. However, this plan was never fully implemented and today, as the result of a variety of uncoordinated developments, the city's zoning plan can be considered obsolete.

With respect to zoning in the Directly Affected Area (DAA) along Phase I corridors, only the CBD and Urafiki/Ubungo industrial area respect the zoning established in 1979. The

Msimbazi (Jangwani) valley that was zoned as a hazardous area has now been invaded with non-permanent residential houses and even with cargo transshipment areas used by trucks. From the junction of Kawawa / Morogoro roads onwards, zoning was mainly residential though now the area has turned into a mixture of residential and commercial use. Kimara, which was zoned as a hazardous area, has now turned into a scattered occupation mixing residential and agricultural land.

5.2.3

Transportation Planning and Infrastructure Implementation and Operation

Transportation in Tanzania is regulated by the Traffic Act of 1973 amended in 1990 through the Road Traffic (Amendments) Act. This regulates traffic movement and behavior. Complementary, the Highway Ordinance Cap 1967 controls the use of roads and related infrastructure.

The Transport Licensing Act (1973) establishes conditions for the licensing of passenger vehicles (both Urban and Intercity).

5.2.4

Expropriation and Resettlement

Land Tenure and Legal Status

The legal framework for resettlement is first and foremost based on the following articles of the Constitution of the United Republic of Tanzania (1977):

- Article 24 (1): Subject to provisions of the relevant laws of the land, every person is entitled to own property, and has a right to the protection of his property held in accordance with law.
- Article 24 (2): It shall be unlawful for any person to be deprived of property for the purposes of nationalization or any other purposes without the authority of law which makes provision for fair and adequate compensation.

Therefore, payment of compensation is both a legal and constitutional right under Article 24 of the Constitution.

Further to the Constitution, the following are the main legal instruments affecting property acquisition and resettlement in Tanzania:

- Land Acquisition Act N° 47 of 1967.
- Land Act N° 4 of 1999.

- Village Land Act N° 5 of 1999.
- Complementary regulations issued in 2001.

The legal basis for compensation / acquisition of private properties or right-of-ways for infrastructure and other development projects is contained mostly in Land Act N° 4 of 1999, Village Land Act N° 5 of 1999 and Land Acquisition Act N° 47 of 1967.

Land Act N° 4 of 1999 is basically about land tenure and land rights, but also addresses issues of compulsory acquisition, mortgages and regularization of unplanned areas.

Land Act N° 4 of 1999 and Village Land Act N° 5 of 1999 and their respective Land and Village Land Regulations, including in particular Supplement N° 16 of 2001, govern the procedures for assessment and payment of compensation for land and unexhausted improvements, loss of accommodation, loss of profit, disturbance and transport.

Section 3 (1) (a) of Land Act N° 4 of 1999 establishes that all Land in Tanzania is public land. Therefore, private land as such does not exist. Occupancy of Land by individuals is granted legally regular status through a “*grant of a right to occupancy*”.

The Government leases Land under the Right of Occupancy system for varying periods at economic ground rents. Such rent is reviewed periodically (normally at 10 yearly intervals). The ground rent paid in respect to government Right of Occupancy is the Land Rent levied under section 7(2) of the Land Ordinance. All urban land in Tanzania is liable to a payment of Rates in lieu of Land Rent as per the Urban Authorities (Rating) Act of 1983.

Further to Public Land, the Land Act recognizes “Village Land” and other forms of customary tenure.

Section 3 (1) (f) of Land Act N° 4 of 1999 provides that “*interest in Land has value and that value must be taken into consideration in any transaction affecting Land*”. Therefore the, acquisition of Land will include compensating owners for bare land in addition to unexhausted improvements.

Sub-paragraph (g) of the same section provides that full, fair and prompt compensation has to be paid to any person whose “*right of occupancy or recognized long-standing occupation or customary use of land*” is affected or interfered with to their detriment. Thus, compensation for land in project-affected areas (which are urbanized and over which no customary forms of tenure prevail), is forthcoming only where its occupancy has been legally granted or is long-standing.

However, in recognition of the existence of informal types of tenure in urban areas, the Land Act provides for the validation of interests in land other than a granted right of occupancy (s. 53-55). In order to address the question of many people acquiring and

occupying urban land otherwise than through a granted right of occupancy, the act introduces the concept of a residential license as a derivative right (section 23 of the Act). Any person who at the commencement of the act (1999) has occupied land in an urban area or peri-urban area as his home for no less than three years, without any officially granted right of occupancy, can receive a “residential license” and is entitled for compensation of land should it be required for a public purpose. Residential licenses have limited validity (maximum of two years) and need to be continuously renewed.

Property Valuation Norms

Valuation Methods are established in Land Act N° 4 of 1999.

Land

This type of compensation applies to all affected households that hold officially granted rights of occupancy or alternatively possess a residential license. Compensation is forthcoming regardless of whether there is need for resettlement or the affected party opts to rearrange within the remaining plot.

In cases where more than 50% of the property is affected, compulsory expropriation of 100% proceeds.

In accordance with section 3 of the 2001 Regulations of Land Act N° 4 of 1999 the basis for assessment of the value of lands affected by the project is the market value of the respective land.

Buildings

In the case of buildings, local practice in Tanzania adopts estimate of surrogate market value through Replacement Cost Methods. This method establishes the price on the basis of the estimated cost of erecting a similar unit at today’s price. The observed condition of the building is taken into account and is used as a basis to allow depreciation to be discounted from the Replacement Cost figure in order to establish what would be the likely price a person may be prepared to pay for the subject property if given opportunity to buy.

The “Depreciated Replacement Cost” thus obtained is considered to be equal to “Market Value”.

Other Legally Established Indemnification and/or Compensation

Regulations of Land Act N° 4 of 1999, made under Section 179 of the Land Regulations which became operational in May 2001, contemplate several complementary compensation allowances for which expropriated parties are eligible. These include:

- Disturbance allowance;
- Transport allowance;
- Loss of profit or accommodation allowance;
- Accommodation allowance.

Disturbance Allowance is payable as a percentage of property valuation in compliance to the provisions of Act N° 4 of 1999. The percentage is the average commercial bank rates offered on fixed deposits during 1 year.

In accordance with Section 11 of the Regulations of Land Act N° 4 of 1999, a transport allowance is paid to all project-affected persons, whether partially or fully affected. The payment is intended to meet transport cost incurred by property owners. It is specifically noted that valuers may apply this compensation to all properties, i.e. to the vast majority of those who will not be resettled. Transport allowance is computed on the basis of market rates for transportation services within the project area, considering the average cost of transporting 12 tons over a distance of 20 Km.

In accordance with Section 9 of the 2001 Regulations of Land Act N° 4 of 1999, the net monthly profit obtained from businesses associated with the affected properties needs to be assessed. Audited accounts need to be analyzed as proof of declared profits. In the absence of audited accounts, valuers can establish loss of profit compensation on the basis of official guidelines. In this case, the amount allowed by valuers does not exceed one million shillings per annum. Compensation is forthcoming on the basis of estimated loss of profit over a 36 month period. This calculation applies also to businesses that are only temporarily affected during the project's construction phase. This compensation will be made to all businesses regardless of the status (owner or tenant) of the affected building. As long as the respective business is affected by the project, the loss of project shall be exclusively and directly paid to the person who loses his/her business premises.

Accommodation allowance applies to all structures or portions of structures that are to be demolished, regardless of whether resettlement is required or not. This allowance is meant to compensate affected peoples for the costs incurred during the period when construction of new structures is under way. In accordance with Section 8 of the 2001 Regulations of Land Act N° 4 of 1999, accommodation allowance is calculated on the basis of monthly rent multiplied by 36 months. Monthly rent is equivalent to the market rental value of the affected part of the property per month.

6.0

Environmental and Social Impact Assessment

6.1

Methodological Framework

The methodology for the assessment of environmental impact adopted in this EIA is based on the specific literature about the subject, namely the works of McHarg (1969), Leopold et al (1971), Munn (1975), Odum (1976) and Canter (1997), amongst others.

In general terms, this methodology intends to facilitate identification of the *potential impacts*, resulting from the actions of planning, implementing and operating the project at issue, on each of the environmental components existing in the influence areas of the project.

The delimitation of the influence areas of the project – Indirect Area of Influence (IAI), Direct Area of Influence (DAI) and Directly Affected Area (DAA) – is carried out by the multidisciplinary technical team involved in the elaboration of the environmental assessment. It is grounded on the knowledge about the major features of the project (implementation and operating actions) and on a preliminary assessment of possible impacts and their likely geographical or spatial range.

The *environmental components* are the elements of the physical, biological and socio-economic environment of the influence areas, which can be affected by impact actions such as: soil and topography, surface and underground water resources, air, vegetation, infrastructure, economy, urban structure, population's quality of life, etc.

The analysis begins with the identification of potential *impact producing actions* of the project. These are described as part of planning activities, project disclosure, construction procedures and activities related to its operation.

Potential *impact producing actions* are then analysed in relation to the environmental impacts diagnosed. By definition, *resulting potential impact* is the one *likely* to be induced by the identified actions, but which shall not necessarily happen.

In order to assure that the identification of impacts be as thorough as possible, an *Interaction Matrix of Impact Actions by Environmental Components*, or simply *Impact Matrix*, is used. Such matrix is basically a cross-check between the project impact actions and the environmental components liable to be affected by the former. It is an adaptation of the procedure developed by Leopold et al (1971). The impact actions are split into groups more or less isolated, and an exhaustive inquiry into the interactions among these groups is carried out. Each cell of the matrix produced is individually analyzed, so as to constitute a comprehensive check-list. The result allows a general overview of the resulting potential impacts.

From the comprehension of the potential impacts it is possible to formulate *Environmental Programs*, which form groups of measures meant to prevent, mitigate, control, monitor or compensate the impact incidence. During the elaboration of each program, the management criteria for the project are followed, to enable the separation of measures by phase (planning, implementation and operation) and the distribution of responsibilities for the execution.

The prevention and mitigation measures tend to be incorporated into the current engineering practices, and often become technical standards or legal requirements. Nonetheless, the guarantee that the environmental programs shall be effectively implemented at different phases of the project is only assured by the commitment taken over at the environmental permit phases and by the subsequent supervision.

Lastly, a conclusion chapter shows the general environmental balance for the project, consolidating the results of the assessments carried out for each environmental component affected.

6.2

Activities With Impact Potential

The impact producing actions associated with the phases of planning, implementation and operation of the DART project are listed and described below. In these phases were included all the activities that may be considered an inseparable part of the project, except those treated as mitigation or compensation measures within the context of the present ESIA study.

A.1 Planning phase or pre-construction phase:

A.1.01 Project disclosure

This action refers to each and every form of project disclosure, including the official public presentation by the entrepreneur (Dar Es Salaam City Council) or other organizations and entities authorized by it, the disclosure of information to third parties, and the news conveyed in the media.

A.1.02 Invitation to bid and engagement of the executive project, construction and other services

This includes all the technical and legal procedures necessary for the effective engagement of the executive project, construction, project management and other complementary services.

A.1.03 Development of the executive project

Comprises the tasks related to the executive project before the beginning of the construction, such as: field surveys (geotechnical prospecting, topography, cadastral surveys, etc.); specification and geometric adjustment of the project (trunk line, interchange ramps and roadworks); specification of engineering works (terminals, stations, etc.); etc.

A.1.04 Initial mobilization

This action incorporates some preliminary managerial, commercial or physical activities, previous to the construction, including: negotiations with land owners of support areas and others; selection of places for the implementation of the construction sites, purchase of building materials; purchase and rent of vehicles, machines and equipment; transportation of material and equipment to the construction sites; etc.

A.1.05 Engagement of workforce

This action deals with the selection and engagement of employees (direct workforce) for the construction.

A.1.06 Implementation of provisional offices and industrial facilities

This action concerns the provision of offices, building sites and other facilities to support the execution of the project, such as asphalt and concrete mixing plants, needed in the pre-construction phase.

A.1.07 Disengagement of the right-of-way (relocation of people and economic activities)

Implementation of the project requires to free the right-of-way through demolition of regular and irregular constructions. It also demands the relocation of informal economic activities existing along the DART alignment.

The actions of removal and demolition shall be preceded by a physical inventory of assets and a social census of dwellers and occupants, as well as the management of the expropriation processes, including a price survey of real estate, indemnification and social support contributions. These procedures shall be incorporated in a *Resettlement Action Plan* (RAP), which constitutes an environmental program for mitigation and/or compensation matters, it's not part of the present action.

A.1.08 Interference relocation project

Comprises the inventory of the air and/or underground utility network to be relocated after consultation with the respective concessionaire companies. It includes relocation procedures and physical-financial schedules for the works.

A.2 Construction or implementation phase:

A.2.01 Fencing or delimitation of each construction site boundary

This action consists in the installation of boarding, striped tapes, warning signalization and other physical barriers on the boundaries of the intervention areas. The delimitation of each site boundary shall take place chiefly at the initial phases of the works, but shall continue during most of the construction process.

A.2.02 Temporary interruptions and rearrangement of local traffic

This action includes rearrangements of traffic on the affected roads and in the surroundings of the work site, including bus stops and pedestrian flow.

A.2.03 Traffic signs and markings

Comprises practical measures to warn the drivers, especially those moving through areas affected by the works, about traffic changes and restrictions on the road network, and inform them about the standard procedures to avoid casualties and unintentional route diversions.

It also comprises guidance signalization to workers in the construction site, topographical markings on the limits of the work sites, the delimitation of areas free from interventions, assignment of routes for vehicle flow within the DAA and other related actions.

A.2.04 Clearing of vegetation

Cutting down the urban landscaping vegetation and isolated trees, as well as the relocation of biomass to the specified destination.

A.2.05 Cleaning of plots of land

Refers to the demolition and/or milling of pavement and the removal of urban fixtures and other existing structures on the public roads of the DAA.

In unpaved areas, this action will involve the removal of the organic horizon of soils and its provisional stockpiling at the work sites (the transportation and disposal at the send-off areas are included in Action A.2.07).

A.2.06 Relocation of interferences (Utilities)

Comprises activities aimed specifically at the relocation or reorganization of air and underground public utility network within the DAA, which can result in occasional interruptions in the supply of public services.

A.2.07 Transportation to and disposal at send-off sites for excess soil and construction debris

Transportation of surplus soil remaining from the excavation, organic soil, demolition debris and other residues derived from the construction works, to the destination areas by pre-established routes .

A.2.08 Extraction and transportation of borrow-pit, base and sub-base material

This involves activities necessary to obtain soil and materials for the formation of the reinforced base and sub-base of pavements to be executed along the DART Project. It includes running borrow-pit areas and operation of soil plants, as well as transportation through pre-established routes on existing roads.

The execution of pavements is not part of this action, but of Action A.2.12.

A.2.09. Excavations and earthwork

This includes earthwork to remove soil and pavement and to open the road for subsequent laying of the base and sub-base to the asphalt or concrete pavement. It also includes spot earthwork, as required for utilities relocation, adjustment of urban drainage components and others.

A.2.10 Adjustment of the rain water drainage

This involves removal of culverts, galleries and other inadequate hydraulic structures, and substitution for larger ones. Works for the enlargement / correction of rain water drainage may stretch out beyond the limits of the DAA, both upstream and downstream, in order to form conduction structures of homogeneous capacity without bottlenecks.

The action excludes demolitions (already included in A.2.05) and excavations (A.2.09). It includes, nevertheless, placement of forms and steel reinforcement , as well as concreting for implementation of the new drainage structures.

A.2.11 Execution of special engineering structures

The project specifies only two special pieces of engineering structure, namely the widening of the culvert on the river bed that crosses Kawawa Road and the construction of new bridges over the Msimbazi river valley, on the alignment of Morogoro Road, including retaining works and other structural elements in concrete. The action may include the following major activities:

- Precast pile driving
- Shaping and form stripping
- Reinforcement
- Concrete production, transportation, compaction and curing
- Concreting
- Assembly of precasted elements

A.2.12 Pavement Construction

Execution of the DART Project pavement (sub-grade reinforcement layers, sub-bases, bases and wearing courses). On the bus lanes, the pavement will be rigid, concrete made, whereas on the remaining lanes the existing asphalt will be restored.

Vehicles and machines to be used in these works are: motor-patrol, tank trucks, closed dump trucks, asphalt spreader trucks, concrete mixer trucks, concrete pumps, agricultural tractors with disc harrow, roller, smoothfaced compaction roller, rubber tired roller, aggregate spreader and concrete finishing machines.

Material inputs for the wearing course (asphalt or concrete, depending on the executive project specifications) shall be acquired at regularly licensed industrial businesses which trade in the IAI. Otherwise they shall be produced at plants specially devised to supply the work site.

A.2.13 Operation of administrative and industrial facilities

This refers to the operation of construction camps, asphalt plants, concrete mixing plants and other industrial facilities necessary for the development of works. They are treated as a single action due to the specific characteristics of their potential impacts, particularly the production of residues, effluents, noise and atmospheric emissions.

Likely places for the location of the construction camps are indicated in Section 2.2.4. It must be highlighted that no accommodation should be provided at the construction sites, because only local residents will be hired.

A.2.14 Execution of civil engineering works

It refers to the execution of the structures at bus stations and terminals, including concrete structures (walls, barriers) and masonry (construction elements at stations or others) that shall be part of the DART project. It comprises mostly the activities of shaping and stripping, reinforcement, concreting and masonry services.

A.2.15 Assembly of metallic structure and electro-mechanical equipment

This action comprises the activities necessary for the assembly of metallic structure (at stations or elsewhere), as well as occasional electro-mechanical equipment (electronic variable message signs, lighting, progressive signal system, etc.)

A.2.16 Demobilization of workforce

At the end of the construction phase, the hired workforce shall be gradually demobilized and dismissed, remaining only the employees necessary for the final tasks (fitting of signs, markings and removal of diversion signalization etc.) and for the beginning of the operation phase.

A.2.17 Removal / relocation of petrol stations

This action involves the demolition or relocation of petrol stations existing along the DART alignment. As these service stations own buried fuel tanks, there are specific risks associated with such action (especially soil and underground water contamination).

A.2.18 Removal of provisional facilities

This includes all the activities concerning the shutdown and removal of construction sites and provisional industrial facilities, and the general cleaning of the affected areas.

A.2.19 Implementation of landscaping, tree planting and complementary urban fixtures

Involves preparation of median strip gardens, including grass, ornamental shrub and tree planting, as well as the fitting of newsstands and other urban fixtures specified in the project.

A.2.20 Final rehabilitation of the DAA

This action refers to the general cleaning of the areas affected by the works, comprising not only the DART alignment, but also the complementary roadworks and required support areas (particularly send-off and borrow pit sites). Whenever needed, it shall comprise services such as erosion rehabilitation, re-planting and others.

A.3 Operation phase:

A.3.01 DART Operation

This action regards the general usage of DART for bus flow and passenger transportation, according to the operating standard specified in the project.

A.3.02 Operation of terminals

Comprises operations at terminals, such as passenger and bus flows, including the “daladalas” feeder service.

A.3.02 Planning and operating control

The planning and operating control activities comprise all the activities related to management necessary for the proper operation of DART, including stations and terminals.

Among the planning activities are the specification of the standard operation routines, special routines for holidays and special events, a programme for conservation and maintenance services, and so forth.

The operating control includes management of user assistance services, safekeeping and property security, as well as the operation of the fare collection systems and variable message signs.

A.3.03 Routine conservation

This action comprises a group of services permanently performed, including activities such as: roadway, station and terminal cleaning; spot corrections of pavement; trim and maintenance of grass and urban trees; minor repairs in special engineering works; repairs and/or substitution of barriers and safety devices; regular painting of traffic markings and other signaling devices; maintenance of the lighting systems and electrical fixtures; and other related activities.

A.3.04 Preventive and corrective maintenance

This action includes works and services which shall be regularly performed, in a preventive manner, or urgently, in a corrective manner.

The main preventive maintenance activities are as follows: pavement rehabilitation, mostly milling and resurfacing; the regular substitution of components of the vertical signage system; and rehabilitation services at special engineering works.

6.3

Impact Receptors

The environmental components that might be affected by the previously described actions are as follows:

C1 Components of the Physical Environment:

C.1.01 Soil and terrains

Soil and terrains to be directly affected by the project has specific topographic characteristics as well as structural compositions that render them more or less vulnerable to erosion.

In terms of geomorphology, the DART alignment along Morogoro Road crosses, in most of its extension, the lower and upper terraces of Coastal Plain, between Kivukoni and Ubungo, whereas the section between Ubungo and Kimara crosses the slopes in the Uplands. The sections of Msimbazi Street and Kawawa Road cross, respectively, the lower and upper terraces of Coastal Plain.

Along the alignment through Coastal Plain the following types of soil are found: in the *lower terrace*, next to the coastline, on the surface, sandy soils, and in the subsequent layers, greyish-brown clayey silt sands; in the section between the coast and River Msimbazi there are surface soils consisting of silt sands and clayey silt sands of low to intermediate plasticity. In the *upper terrace*, between River Msimbazi and Ubungo, the surface soils consist of silt sands and clayey sands underlain by weathered sandstones; Msimbazi valley is filled with alluvial and organic soils consisting of sands, silts, clays and gravels. Thus, crossing the Msimbazi creek will require special construction methods.

In the section through the Uplands, the soils consist of mainly dense clayey sands with brownish patches followed by kaolinitic clayey sands and sandy clays. The clayey sands contain swelling minerals and are not good as sub-grade soils for roads. Road construction on the Uplands clayey sands often requires importation of improved sub-grade soils.

C.1.02 Surface water resources and natural drainage

The water bodies most vulnerable to the construction and operation impacts of the DART are those whose contribution basins intersect with public roads where bus lanes will be implemented, and those whose river beds are next to sections located downstream from the works.

The only drainage lines that intersect with the DART alignment are:

- River Sinza (a tributary of River Msimbazi), which crosses Kawawa Road;
- River Msimbazi, which crosses Morogoro Road.

The sections of these watercourses most likely to be affected by the Project are those between the point of intersection with the alignment and the respective mouths.

C.1.03 Underground water resources

The underground water resources that may be affected by the Project correspond to the alluvial aquifers of Rivers Msimbazi and Sinza. It might be necessary to lower the water table for the execution of engineering works at the valley crossings.

Impacts related to accidental leakages of fuel or other dangerous products during the construction or operation will be of a local nature, limited to the surface water table, with no significant effects on deep aquifers.

C.1.04 Air

In order to assess the project impacts on local air quality, the major aspects to be considered in the Dar Es Salaam region are the atmospheric dispersion conditions related to wind circulation and precipitation frequency, as well as the current iso-concentrations of atmospheric pollutants in the closest areas to the DART alignment (base-lines).

At the DART operational phase, air quality will be positively affected as a result of changes in pollutant emission standards.

C.2 Components of the Biotic Environment:

C.2.01 Vegetation

The vegetation in the DAA subject to removal at the construction phase is limited to isolated trees, native and exotic, of different sizes, part of urban vegetation, in addition to small sections with typical meadow vegetation (Rivers Msimbazi and Sinza).

C.2.02 Fauna

As to the fauna, the only group likely to experience a perceptible impact due to the project are birds. The intervention scale and the landscape context of the project will restrict the impacts on birds to a local dimension, circumscribed to the DAI.

C.3 Components of the Human Environment:

C.3.01 Road infrastructure and traffic

The road infrastructure likely to be affected by the project includes not only the roads where the bus lanes will be implemented, but also the cross and parallel streets closest to the alignment, whose traffic will be affected at the construction and operation phases, in addition to the roads that connect the work sites with the support areas.

The main roads to be directly affected by the engineering works are:

- Morogoro Road
- Kawawa Road
- Msimbazi Street
- Kivukoni Front
- Sokoine Drive

Other important roads which the traffic might be indirectly affected are mainly the intersections with BRT roads, such as:

- Bibititi
- Lumumba
- United Nations
- Shekilango
- Mandela/Sam Nujoma
- Bagamoyo/Ali Hassam
- Dunga
- Kinondoni
- Mwinyjuma
- Malongwe
- Mlandizi
- Swahili
- Uhuru
- Lind
- Nyerere

The traffic at the Central Business District (CBD) area shall be relocated during the works and subject to permanent alteration in operation phase, affecting a series of central roads.

In general terms, at the IAI scale, with the elimination and relocation of the “daladala” services as a result of implementation of trunk and feeder lines, the traffic on streets and roads used by these services will be heavily impacted.

C.3.02 Public transportation

The public transportation services in Dar Es Salaam urban area will be affected as a whole during the DART operation and construction phases. During the engineering works there will be a relocation of the “daladala” services, whereas at the operation phase the introduction of new buses with high capacity and the rationalization of the whole operating system (trunk lines and feeder services) shall promote an increase in mobility and a reduction in travel times for all users.

C.3.03 Urban structure

Urban structure is defined as the way in which different land uses are organized and distributed in the urban space. That is, what the configuration of business centres and sub-centers, residential districts of different income levels and industrial complexes is like, and the way these different land uses relate within the structure.

The main areas to be affected by the project are those located along the DART alignment, that is, the standards of land use and occupation in the areas adjacent to Morogoro, Kawawa, Msimbazi, Kivukoni Front and Sokoine Drive roads, within the DAI. Owing to the increase in accessibility within these areas, there may be impacts such as the inducement to increase occupation density and vertical development, in addition to the increase and decrease in property value, including the area outside DAI.

C.3.04 Population’s quality of life

In the quality of life component, many aspects are taken into account, including conditions related to public health and environmental quality (air pollution, noise generation, landscape perception) as well as other variables likely to be changed by the project (wealth, travel times, etc.).

On the one hand, the project will cause effects on the population of residents, land-owners or workers within the DAA, which shall experience the expropriation, resettlement and/or job relocation effects. Similarly, but with weaker intensity, the communities bordering on DAA will experience changes in quality of life, both during the construction as well as during the operation phases.

On the other hand, the population within the IAI as a whole will benefit from the increase in the rationality and reliability of public transport in town, chiefly from the increase in mean speeds and the reduction in travel times of daily trips.

C.3.05 Economic activities

The focus economic activities involve several types of typically urban activities, namely business, services and industry, formal or informal, developed in the area along DART (DAI) and, broadly speaking, throughout the city (IAI).

Negative impacts may happen, either related to property expropriation or to the relocation of people and activities within the DAA. On the other hand, positive impacts are expected for the economic activities along the alignment, at the DAI, due to the increase in accessibility and to urban revitalization deriving from DART implementation. At the IAI level there may be benefits for the economic activities, in the zones indirectly favoured by accessibility gains.

C.3.06 Physical and social infrastructure

The infrastructure component comprises all networks of public utilities (water, sewerage, electric energy, telecommunications), except the road network and the public and/or private equipment and services of education, health and social work.

The impact on public utility networks will be rather limited, circumscribed by the DAA and DAI, which can result in temporary interruptions to public services during the execution of works owing to the necessity of interference relocation along the DART alignment.

As to social infrastructure, during the construction phase there may be negative impacts, although of a temporary nature, to the population willing to access the existing equipment and services within the band from 100 to 150 meters away from the DAA.

At the operational phase, positive impacts are likely to happen with the increase in accessibility and mobility provided by the DART operation.

C.3.07 Public finances

This component refers to the situation of revenues and expenses of the public administration, mostly at the local level.

As described in Section 2.3, the total cost of the engineering work is estimated at US\$ 110 million, 70% of which shall be financed by the World Bank as subsidies in the form of grants, and only 30% will be funded by the government of The United Republic of Tanzania. This means that there will be a relatively small commitment of public funds to the project when compared to a hypothesis of total funding by the public administration.

Furthermore, the execution of works and the DART operation will produce indirect positive effects on the tax revenue.

C.3.08 Archaeological, Historical and Cultural Heritage

This comprises the property goods, movable and immovable (pre-colonial archaeological sites, of contact and historical, ethnographic value sites, constructions and building groups of vernacular expression and remarkable landscape) and collective cultural expressions present in the area of direct influence of the project.

There will be no disturbances to archaeological sites or demolition of historical or cultural buildings during the construction phase. However, some areas adjacent to important buildings can be affected by the works, such as:

- The access to the President's House and all related institutional buildings
- The access to the Ferry and the Fish Market
- The institutional buildings along Kivukoni Front and the religious buildings
- The access to the City Hall
- The Institutional Buildings along Morogoro Road and the religious buildings near Bibititi Mohammed Road
- The religious buildings at Magomeni

6.4

Impacts Identification and Description

List of Potential Impacts

Impacts during Planning and Construction Phases

Physical Impacts:

Potential impacts on soils and terrains

- Erosion and soil run-off during construction
- Risk of soil contamination by fuel, lubricants and other dangerous substances during construction

Potential impacts on surface water and natural drainage

- Increased turbidity and other negative water quality impacts
- Increased sedimentation of rivers and flood plains

Potential impacts on ground water

- Risk of underground water contamination during construction

Potential impacts on air

- Air quality impacts during construction

Biological Impacts:

Potential impacts on vegetation

- Removal of trees and landscaping along corridor right-of-way (ROW)

Potential impacts on birdlife

- Temporary reduction of trees, fruits and seeds for bird nesting and feeding

Socio-Economic Impacts:

Potential impacts on road infrastructure and traffic

- General increase in traffic congestions during construction
- Temporary alterations in the local patterns of traffic circulation
- Use of local street network by construction vehicles
- Local street pavement deterioration due to construction related traffic
- Temporary disturbance of pedestrian circulation patterns

Potential quality of life impacts

- Interference with local traffic during construction
- Project induced social unrest during planning and construction
- Direct and indirect employment generation during construction
- Loss of employment in adjacent commercial activity during construction
- Risk of construction related accidents
- Increased noise and vibration levels along construction fronts
- Public utility services interruptions during construction
- Expropriation
- Resettlement of families

Potential impacts on economic activities

- Displacement of economic activities along the corridor
- Reduction of the intensity of commercial activity along the corridor during construction

Potential impacts on physical and social infrastructure

- Disturbance and/or relocation of public utilities

Potential impacts on public finances

- Appropriation of part of the public sector's investment capacity
- Increase in tax revenue during corridor construction

Potential impacts on architectural monuments and cultural property

- Disturbance of architectonic landmarks and other cultural property

Impacts during Operation Phase

Physical Impacts:

Potential impacts on soils and terrains

- Increased impermeabilization of the right-of-way

Potential impacts on air

- Impacts on air quality during operation

Biological Impacts:

Potential impacts on vegetation

- Increase of urban trees as a result of project landscaping implementation

Socio-Economic Impacts:

Potential impacts on road infrastructure and traffic

- Permanent alteration of street capacities and local patterns of traffic distribution
- Reduction in the availability of external parking spaces
- Permanent restriction to transversal flows of pedestrians
- Changes in traffic level of streets affected by “daladala” route rationalization
- Changes in traffic level of streets affected by permanent re-routing of passenger vehicles
- Increase in the level of bicycle use
- Increase of the barrier effect along the corridor

Potential impacts on public transportation

- Improvement in the quality and capacity of public mass transport serving the IAI population
- Re-routing and rationalization of “daladala” lines
- Reduction of total bus / kilometers in the IAI
- Reduction of operational costs per passenger / kilometer in public transport along the DART corridor

Potential impacts on urban structure

- Induction to changes in land use patterns within DAI
- Increase in real estate values
- Risk of localized real estate depreciation
- Potential for increased urban density within the DAI
- Increased potential for radial expansion of the urbanized area
- Development of new urban sub-centers or expansion of existing ones

Potential quality of life impacts

- Reduced travel time for corridor users
- Alteration of total cost of travel for corridor and feeder line users
- Reduction of total direct employment necessary for operation of the public transportation system of the IAI
- Increase in the potential for employment generation in the DAI as a result of increased density
- Disturbances to local population as a result of commercial activity displacement
- Local alteration of noise level during operation
- Landscape alteration and urban requalification of areas adjacent to the corridor
- Alteration of the number of traffic accidents

Potential impacts on economic activities

- Induced change in commercial and service activities along the corridor
- Increased potential for retail shops and service providers in the areas surrounding stations and terminals
- Potential income loss for daladala operators

Potential impacts on physical and social infrastructure

- Increase in the serviced area of key components of local social infrastructure

Potential impacts on public finances

- Indirect increases in property tax revenue as a result of real estate value increases and intensification of economic activity along the corridor

Impact Matrix (Interaction Matrix of Impact Actions by Environmental Components)		Environmental Components (Impact Receptors)																
		C.1 Physical Environment				C.2 Biotic Environment		C.3 Human Environment										
		C.1.01 Soils and terrains	C.1.02 Surface water and natural drainage	C.1.03 Underground water	C.1.04 Air	C.2.01 Vegetation	C.2.02 Fauna	C.3.01 Road infrastructure and traffic	C.3.02 Public transportation	C.3.03 Urban structure	C.3.04 Population's quality of life	C.3.05 Economic activities	C.3.06 Physical and social infrastructure	C.3.07 Public finances	C.3.08 Archaeological, Historical and Cultural Heritage			
Activities with impact potential	A.1	Planning phase or pre-construction phase																
	A.1.01														8.02			
	A.1.02															11.01, 11.02		
	A.1.03															11.02		
	A.1.04														8.08		11.02	
	A.1.05														8.03		11.02	
	A.1.06	1.01, 1.02	2.01, 2.02	3.01	4.01			7.03, 7.04				8.01, 8.05, 8.06				11.02		
	A.1.07											8.09	9.01				12.01	
	A.1.08															11.02	12.01	
	A.2	Construction or implementation phase																
	A.2.01							7.01, 7.02, 7.05				8.01, 8.02	9.02				12.01	
	A.2.02							7.01, 7.02, 7.03, 7.05				8.01, 8.02, 8.04	9.02				12.01	
	A.2.03							7.02, 7.05										
	A.2.04	1.01			4.01	5.01	6.01	7.03, 7.04, 7.05				8.01, 8.02, 8.05, 8.06					12.01	
	A.2.05	1.02		3.01	4.01			7.01, 7.02, 7.03, 7.04, 7.05				8.01, 8.05, 8.06	9.02				12.01	
	A.2.06	1.01, 1.02	2.01, 2.02	3.01	4.01			7.01, 7.02, 7.03, 7.04, 7.05				8.01, 8.02, 8.05, 8.06, 8.07	9.02	10.01				
	A.2.07	1.01, 1.02	2.01, 2.02	3.01	4.01			7.01, 7.03, 7.04				8.01, 8.05, 8.06				11.02		
A.2.08	1.01	2.01, 2.02		4.01			7.01, 7.03, 7.04				8.01, 8.05, 8.06				11.02			
A.2.09	1.01	2.01, 2.02		4.01			7.01, 7.02, 7.03, 7.04, 7.05				8.01, 8.05, 8.06							
A.2.10	1.01	2.01, 2.02	3.01	4.01			7.01, 7.02, 7.03, 7.04, 7.05				8.01, 8.05, 8.06							
A.2.11	1.01, 1.02	2.01, 2.02	3.01	4.01			7.01, 7.03, 7.04, 7.05				8.01, 8.05, 8.06							
A.2.12	1.02, 13.01	2.01	3.01	4.01			7.01, 7.03, 7.04, 7.05				8.01, 8.05, 8.06							
A.2.13	1.02	2.01	3.01	4.01			7.01, 7.03, 7.04				8.01, 8.05, 8.06							
A.2.14	1.01, 1.02	2.01, 2.02	3.01	4.01			7.01, 7.02, 7.03, 7.04, 7.05				8.01, 8.05, 8.06							
A.2.15				4.01			7.03, 7.04				8.01, 8.05, 8.06							
A.2.16																		
A.2.17	1.02	2.01	3.01	4.01			7.02, 7.03, 7.04, 7.05				8.01, 8.05, 8.06							

Impact Matrix (Interaction Matrix of Impact Actions by Environmental Components)			Environmental Components (Impact Receptors)												
			C.1 Physical Environment				C.2 Biotic Environment		C.3 Human Environment						
			C.1.01 Soils and terrains	C.1.02 Surface water and natural drainage	C.1.03 Underground water	C.1.04 Air	C.2.01 Vegetation	C.2.02 Fauna	C.3.01 Road infrastructure and traffic	C.3.02 Public transportation	C.3.03 Urban structure	C.3.04 Population's quality of life	C.3.05 Economic activities	C.3.06 Physical and social infrastructure	C.3.07 Public finances
Activities with impact potential	A.2.18	Removal of provisional facilities	1.01, 1.02	2.01	3.01	4.01			7.03, 7.04			8.05, 8.06			
	A.2.19	Implementation of landscaping, tree planting and complementary urban fixtures					15.01		7.03, 7.05			8.01, 8.05, 8.06, 19.07			
	A.2.20	Final rehabilitation of the DAA							7.03			8.06, 19.07			
	A.3	Operation phase													
	A.3.01	DART Operation				14.01			Group I.16	Group I.17	Group I.18	Group I.19	Group I.20	Group I.21	22.01
	A.3.02	Operation of terminals				14.01			Group I.16	Group I.17	Group I.18	Group I.19	Group I.20	Group I.21	22.01
	A.3.03	Planning and operating control							Group I.16	Group I.17		19.08			
	A.3.04	Routine conservation										19.07, 19.08			
	A.3.05	Preventive and corrective maintenance										19.07, 19.08			

6.4.1

Potential Impacts During Planning and Construction Phases

Physical Impacts

1.1 Potential impacts on soils and terrains:

1.01 Erosion and soil run-off during construction

All the excavations specified during the execution of pavements and the installation of equipment for DART will be carried out in urbanized land, that is, on existing roads, or in urbanized plots of land, bordering on the former.

As there are no steep slopes along the Project alignment, no relevant impacts of erosion and soil run-off are expected in the areas located downstream the working faces. Nevertheless, at the final section of Morogoro Road between Ubungo and Kimara (Uplands), the clayey sands with swelling minerals are not good as subgrade soils for roads. Thus, in this road section, a borrow-pit will be required for the formation of the sub-base.

In the rest of the alignment through the Coastal Plain, the most common type of soil along the alignment is sand, with different compositions of silt and clay. In River Msimbazi valley, the presence of alluvial soils with high dampness and plasticity will require special construction methods for the engineering works.

Activities such as excavations for the removal of pavements, strengthening of base and sub-base or relocation of underground interferences will require little earthwork, implying a formation of piles or lay-by pits in places scattered along the working faces. Such piles, if not properly protected, may cause soil run-off problems during the event of heavy rain.

The excavations for the execution of engineering works or culverts at the drainage crossings, as in the case of the widening of bridges over River Msimbazi, present the greatest potential for run-off of sediments to the watercourses.

In the send-off and borrow pit areas there may be impacts of erosion or undermining of slopes due to inadequate disposal of demolition residues (pavements, gutters, kerbs and other structures existing in the plots of land to be expropriated) or of soils remaining from excavations, and to the removal of soil matter (borrow pits).

The support areas may be licensed and used exclusively to meet the project demands. They can be operated by the contractor himself, or alternatively, licensed and commercially operated by third parties. In both cases, the potential impacts of soil erosion and run-off might be prevented or mitigated by the correct disposal or removal of materials during operation.

1.02 Risk of soil contamination by fuel, lubricants and other dangerous substances during construction

During the construction, there may be accidents with vehicles and equipment on duty, followed by fuel or lubricant oil leakages. This risk will exist all through the project schedule, but it is of low intensity and restricted to the DAA. Given that most part of the DAA is already impermeable, any accidental leakage may be easily identified by those in charge, who shall apply the due corrective measures.

Notwithstanding, as it will be necessary to remove some petrol stations along the DART alignment, there will be a risk of soil contamination associated with buried fuel tanks. The petrol stations whose tanks and/or pumps which will be probably affected are listed below:

- Lybia Petrol Station (Morogoro Road, km 3+050 – 3+090);
- BP Petrol Station (Morogoro Road, km 3+870 – 3+910);
- Orix Petrol Station (Morogoro Road, km 4+090 – 4+140);
- Gapco Petrol Filling Station (Morogoro Road, km 6+000 – 6+010);
- Oil Com Filling Station (Morogoro Road, km 7+350 – 7+370);
- Total Petro Station (Morogoro Road, km 9+300 – 9+320);
- Oryx Petrol Filling Station (Morogoro Road, km 10+340);
- Gapco Petrol Station (Morogoro Road, km 5+550 – 5+660);
- BP Petrol Station (Kawawa Road, km 32+040 – 62+060).

If the removal of petrol stations fuel installations and the resulting risks are the entrepreneur's responsibility, the remedy for the likely environmental liabilities is the service station owner's responsibility. Since the DART Project could not wait for each station owner to solve any pollution problem, Dar es Salaam City Council will formalize agreements with the owners in order to carry out the removal of contaminated soil and the remedy for the existing liabilities. It must be observed that the removal of soils will be carried out within the schedule of works, but the remedy for liabilities shall be subject to another schedule, longer than the former, and independent from the DART execution term.

It is known that, at the present time, there is no suitable place in Tanzania for the disposal of fuel or lubricant residues, so it will be necessary to provide a place for the encapsulation, according to international technical and environmental standards.

It must be emphasized that the area where the intercity bus maintenance takes place will be transformed into a maintenance garage for the DART buses. In this case, the removal of contaminated soils and the remedy for the environmental liability shall be the City Council's direct responsibility. In addition to this area, the DART project specifies the construction of another maintenance garage, at a second spot. In both cases all the environmental caution must be taken in the collection and disposal of the washing effluents, giving preference to the construction of new areas for the tanks, protected by dam embankments.

In the slope or send-off areas at the construction site, there may be leaching of contaminating substances, with a potential negative effect on soil and underground water. In order to prevent this impact, the send-off area shall be technically prepared to receive the construction residues, and duly licensed by the competent authorities.

The risk of soil contamination by accidental leakage of dangerous products will also exist during the operation phase, and there is no reason to suppose that it will be greater than in the current situation. On the contrary, traffic segregation, strengthening of road capacity and reduction in the amount of "daladala" services in operation will promote gains in terms of traffic safety, and therefore, the reduction in accidents and risks of leakage.

1.2 Potential impacts on surface water and natural drainage:

2.01 Increased turbidity and other negative water quality impacts during construction

Rain over the exposed soil area during the engineering works, and the usage of support areas (send-off, borrow pit and construction sites), may cause the run-off of fine particles towards the nearby watercourses, promoting an increase in the amount of suspension solids and the resulting increase in turbidity

Other parameters for the assessment of water quality, such as pH, content of oil, grease and organic matter, may also be affected during the construction phase. The activities which can change such parameters are the undesirable run-off of residual water from concreting, washing of concrete mixers at inadequate spots; leakage of fuel, oil and lubricant; residual water from vehicle washing in the maintenance areas, and leakages or inadequate disposal of domestic sanitary effluents at the construction sites.

These potential risks may affect the watercourses crossed by the DART alignment (Rivers Msimbazi and Sinza) in the sections immediately downstream from the working faces, as well as other watercourses next to the support areas. Turbidity during the rainy season can be prevented or minimized. The leakages of dangerous products and sanitary effluents require corrective measures. The inadequate disposal of effluents (sanitary, contaminated residual water), should be avoided applying the standard measures for the environmental control of construction sites and works.

The area currently used for the maintenance of intercity buses and which will be transformed into a maintenance garage for DART buses is located beside River Sinza, where environmental liability is high due to direct or indirect contamination of surface water. In this case liability falls on the entrepreneur. At the operational phase, the contamination risk of the watercourses next to the vehicle maintenance areas will be very low since new impermeable yards and areas for tanks and water-oil collection / separation devices will be built.

2.02 Increased sedimentation of rivers and flood plains

The increase in the sanding-up rate is an impact that can happen at the construction phase as a result of the earthworks. Increase in the areas of soil exposed to rain will increase the volume of sediments transported and deposited in the plains and river beds.

High intensity precipitation during the execution of works will increase risk of sedimentation. The sanding-up process promotes spot changes in the morphology of the affected sections of the river, likewise the obstruction of drainage will have indirect impacts on the riparian vegetation. Sedimentation also causes floods to happen in adjacent upstream areas, due to the barrage effect. The affected watercourses tend to redress their balance standard in the medium to long term, producing gradual run-off of material accumulated at a given spot to downstream sections.

The watercourses prone to such impact are those crossed by the DART, that is, Rivers Msimbazi and Sinza, in addition to watercourses next to the send-off and borrow pit areas.

1.3 Potential impacts on underground water:

3.01 Risk of underground water contamination during construction

Underground water can suffer the impact of works only indirectly, by means of the leaching of contaminated soils, both at the working faces and construction sites (accidental leakages of fuel and other dangerous products) as well as at the send-off area (debris disposal).

As previously observed, environmental liabilities (decontamination of water table) will only be on the entrepreneur in the maintenance area of intercity buses (future garage). The contaminated soils shall be removed within the construction schedule, but the remedy for other liabilities (contaminated water table) will be carried out in an independent manner, within a specific schedule. In the case of liabilities at automotive service stations, its remedy will be the station owners' responsibility.

I.4 Potential impacts on air:

4.01 Air quality impacts during construction

During the implementation phase, the potential impacts on air quality will be located mostly in the excavation and demolition areas (DART alignment and engineering work areas), in the circulation area for vehicles and equipment on duty, and in the support areas.

Re-suspension of dust may occur as a result of land cleaning, demolitions, formation of pavement base and sub-base, paving and circulation of vehicles on duty on non-paved roads, either next to the working faces or in the way to support areas. This is the temporary impact, likely to happen when these activities are developed within relatively long terms under dry weather conditions. They can be easily mitigated by regular moistening of the used surfaces.

As to atmospheric emissions due to fuel combustion during construction, these shall be of three types:

- Moving source emissions, as a consequence of the flow of vehicles and equipment on duty;
- Fixed source emissions, deriving from the operation of industrial facilities (asphalt plants and concrete mixing plants) which might be implemented or outsourced to supply material inputs to the project;
- Increase in the vehicular emissions associated with the temporary interruption of lanes and/or the reduction of mean speeds on the roads directly affected and in the surrounding road network.

In the two former cases, the potential of the impact is related to the maintenance conditions of vehicles, equipment and industrial facilities. In the latter case, the potential of the impact is related to the intensity of modifications, imposed on the traffic and on the importance of the affected roads, which will change the conditions of traffic flow and traffic volume.

Considering the amount of moving and fixed sources currently existing at the DAÍ as compared to the vehicle fleet and equipment to be mobilized due to the engineering works, it may be reasonable to assume that the negative impacts on air quality during the construction, will be temporary and small-scale.

Biological Impacts

I.5 Potential impacts on vegetation:

5.01 Removal of urban trees and landscaping along corridor right-of-way

Within the DAA, an inventory of trees showed that there are 1,183 units to be potentially removed, including native and exotic species (see Section 4.4.5). However, some large-sized individuals will be preserved due to geometric adjustments to the DART alignment.

Given the DAA is an urbanized area and no forest will be affected, the impact on vegetation may be considered low-scale. Later, a positive impact will be gained from urban tree planting and landscaping included in the DART project.

I.6 Potential impacts on birdlife:

6.01 Temporary reduction of trees, fruits and seeds for birds nesting and feeding

During the construction term, part of the birdlife which lives in or feeds from the urban trees existing in the DAA or its immediate surroundings will be driven away, moving out to neighbouring areas. Besides the increase in noise levels, the removal of isolated trees will bring about the reduction in the availability of fruit and trees for birdlife feeding and nesting.

Once the landscape project implemented and urban trees planted and grown, this impact will gradually be reverted.

Socio-Economic Impacts

I.7 Potential impacts on road infrastructure and traffic:

7.01 General increase in traffic congestions during construction

All of Phase 1 of the BRT system will be implemented simultaneously, within a two year construction schedule. This will imply in significant limitation of capacity along the alignment, requiring provisional rearrangement of traffic and associated disturbances to pedestrians and adjacent land use. Due to limited extension of Dar Es Salaam's road network, provisional detours are not feasible. Thus, traffic management procedures during construction will have to be restrained to the project's Directly Affected Area (DAA).

Given the importance of the selected corridors, it is likely that impacts on traffic congestion will be widespread and will affect a significant part of Dar Es Salaam's main avenues during most of the construction period.

Though intense, this is a provisional impact that will cease once the project is in operation.

7.02 Temporary alterations in the local patterns of traffic circulation

The implementation process of DART (Phase 1) will require a series of provisional changes in the local standard of traffic distribution.

The change and/or strengthening of pavements will imply a partial interruption of traffic on the roads directly affected, compelling the temporary relocation of traffic within the DAA limits. In addition to the activities of demolition and paving on the BRT roads, the cross street traffic will be affected by the adjustments specified for the intersections. The project implementation will also compel traffic relocation on the Central Business District (CBD) road network, as per described in the “Programme for Traffic Management During Construction” (Section 6.5, P.05) and detailed in Annex 10.

As with the previous modifications, despite the intensity of changes in the patterns of road traffic, these changes shall be temporary, ceasing after the end of works. The exception is the CBD, where a new permanent scheme of traffic will be implemented at the operational phase (see Section 2.6).

7.03 Use of local street network by construction vehicles

During construction, there will be heavy duty vehicle traffic along the directly affected roads and in the rest of the network. It will be more intense on DART trunk roads because the local network lacks sufficient roads or expressways. Consequently, the intensity of impact 7.01 (increase in traffic congestions) will tend to rise.

This will also affect minor roads which connect the working faces to the support areas (send-off, borrow pit areas) and to the asphalt and concrete mixing plants. Nonetheless, in such cases, the impact should be less intense due to the lower traffic volume on those roads.

The usage of main roads and secondary routes by heavy duty vehicles will tend to decrease as demolition and paving works come to an end.

7.04 Local street pavement deterioration due to construction related traffic

The traffic of heavy vehicles on duty at the construction site will cause the wear and tear of the road pavements, especially those assigned to the implementation of DART Phase 1.

Such impact, also of a temporary nature, will be reverted after the end of works, given that new concrete pavements will be built on the segregated bus lanes, and the asphalt pavements will be rehabilitated / resurfaced. Nevertheless, the traffic of heavy vehicles on local roads may increase the deficiencies currently observed, since most part of the local

road network, with the exception of the CBD roads and the major city links, is not paved and presents no drainage system.

7.05 Temporary disturbance of pedestrian circulation patterns

During the construction phase, there will be temporary interferences in the pedestrian circulation patterns, mostly on the roads directly affected and at the crossroads with the main local roads. Both the cross and parallel routes will be altered due to lane interruption, relocation of bus stops and the implementation of physical barriers (boarding, etc), as well as the implementation of provisional footbridges.

1.8 Potential impacts on population's quality of life:

8.01 Interference with local traffic during construction

During the construction works it will not be possible to divert the traffic on the avenues to other road sections, given the scarcity of alternative routes. Hence, in order to enable the occupation of part of the right-of-way by the construction teams without transferring the traffic to other sections, it will be necessary to stagger the relocation of traffic lanes.

This process, needless to say, shall cause a disruption to the users of the affected avenues, including freight vehicles, passenger vehicles and daladalas.

In the case of the Msimbazi Street branch, the disruption shall be particularly strong as a function of the relatively narrow right-of-way and of the continuous commercial activity along the link. Alternative roads will be inevitably used, affecting the conditions of traffic and noise therein.

A similar situation is expected along the Morogoro Road section within the CBD. In contrast, the problems expected on Kivukoni Road and Sokoine Drive, also in the central area, will be smaller, due to less intense traffic along these links.

Along the remaining parts of Morogoro Road the right-of-way is wider and the relocation should be possible with reduced impact on the road capacity during construction. On the other hand, on the Kawawa Road branch the available spaces are a little smaller.

8.02 Project induced social unrest during planning and construction

During the pre-construction stage the project disclosure may generate a substantial mobilization of the population employed or living in the areas directly affected by the roadworks.

Indeed, there will be concern and enquiries by the owners of properties to be expropriated, people living in zones prone to direct effect, owners and employees of shops and stores located along the corridor and other people whose activities and/or daily trips will be directly affected.

The mobilization of all these stakeholders, both for and against, shall extend until the construction stages, particularly the period of negotiation of indemnities and other complementary measures included in the Resettlement Action Plan for the present project.

8.03 Direct and indirect employment generation

It is expected that the works will last for twenty-four months with a workforce of roughly 450 during the peak season. This peak period is estimated to last approximately eight months. Out of the total staff, 70% will be direct and 30% indirect workforce. It is also estimated that up to 20% of the job positions may be filled by expatriate workers, coming from the country of origin of the company that wins the bid for the works.

In spite of the fact that the positive impact will cease after the end of works, it will provide a direct benefit to the families of all engaged workers.

8.04 Loss of employment in adjacent commercial activity during construction

The businesses facing the corridor shall be negatively affected during the construction, especially when the roadworks impose access difficulties.

If the reduction in their income level is significant, it may produce the dismissal of some workers. In the case interferences produced by the roadworks compel the temporary closure of a business, the dismissal of all workers will be a possibility.

The Socio-economic Census developed during the elaboration of the Resettlement Action Plan (RAP) Part A has identified a total of 70 to 75 workers in the business organizations to be partially or fully expropriated. It is estimated, based on the current status of the Socio-economic Census, Part B, that the number of employees in the businesses directly affected in this section of the alignment will be around 40 to 50 (preliminary research).

It must be emphasized that this number does not include workers of businesses provisionally affected during the construction and therefore not subject to expropriation (that is, not covered by the Socio-economic Census). In fact, the number of workers that may be affected by this impact may be considerably higher.

8.05 Risk of construction related accidents

At the construction phase the activities that represent accident risks for workers at the contractors' service (occupational risks) are as follows:

- Work at high traffic volume areas (risk of pedestrian casualty);
- Vehicle driving (collision risk);
- Transportation, movement and handling of materials and inputs;
- Passenger transport;
- Transportation, loading and unloading of explosives;
- Transportation, loading and unloading of dangerous products (fuel, oil, etc.);
- Warehousing and handling of fuel and flammable materials;
- Operation of heavy machines and equipment;
- Demolition of pavements and structures;
- Excavation works;
- Concreting Works (shaping, reinforcement, concreting, form stripping);
- Works at high places (relocation of air utilities, construction of bridges);
- Tree cutting;
- Works with the risk of electric shock (operation of electrical appliances and equipment, relocation of power distribution posts).

Apart from the occupational risks, the construction will also bring about accident risks for third parties, namely drivers and pedestrians on the move at DAA, such as: pedestrian casualties, vehicle collisions, falling into pavement holes, electric shock and other associated risks.

8.06 Increased noise and vibration levels along construction fronts and routes to support areas

The population who lives or works in places next to areas directly affected by the project will experience an increase in the levels of noise and vibration during the construction.

This impact will be stronger during the initial stages of works, when the activities of demolition of pavements and structures, relocation of interferences and transportation of rubble as far as the send-off area will require the use of heavy equipment and vehicles. It must be noted, though, that the roads subject to the implementation of DART at phase 1 already present high traffic volume, so that the current levels of noise and vibration at DAA are already significant.

The intensity of this impact shall vary according to the degree of severity or sensitivity of those affected. In general terms, the most sensitive recipients to noise are schools, hospitals and residential areas.

Along Kawawa Road the existing schools are not located next to the road alignment, so that the impact shall not be significant. Otherwise, in the Morogoro Road section between Kawawa Road and Kagera Street there are around half a dozen schools and one hospital bordering on the road which may be affected by such activity. There is also a hospital very close to the area planned for the location of Ubungo Terminal.

The increase in the noise and vibration levels also tends to occur in the case of sections far from the urban area, which will be used by trucks for the transportation of materials between the support areas and the working faces. On the other hand, the amount of critical recipients will be, in such cases, substantially smaller.

8.07 Public utility service interruptions during construction

During the construction phase, some disturbances to the supply of some public services may occur, sometimes due to the need to completely relocate the services, and in other cases because of pavement improvement work or similar direct intervention where the services are located.

The companies whose utilities supply may be affected are: TTCL (public telephone), TANESCO (power supply), DAWASCO (water supply) and DAWASA (sewage).

Though services interruption cannot be avoided in some cases, the duration of interruptions is expected to be minimal since any relocation work will be completed before removal of the existing utility lines.

8.08 Expropriation

The necessities of expropriation along the corridor and complementary roadworks are distributed unevenly along the alignment. On the whole, the geometry of the corridor design requires expropriation, mainly at the stations, where the cross section needs to be wider.

The following table synthesizes the information on the need of expropriating for Parts A and B of DART Phase 1, specifying the cases of partial and full expropriation.

Table 6.4.1.a
Number of Affected Properties

Types of Property	Phase I – Part A (Final)	Phase I – Part B (Estimate)
Residences to be totally affected	9	69
Residences to be partially affected	5	0
Commercial establishments affected within residences	11	21
Totally affected independent commercial establishments	7	21
Partially affected independent commercial establishments	68	2
Other affected buildings	12	1
TOTAL AFFECTED PROPERTIES	112	114

It is expected that a total of 226 properties will be affected, out of which 75 will be partially affected. Nevertheless, the most affected types of use will be the businesses which develop in front of dwellings, facing the right-of-way

Further details on the necessary expropriations are found in the Resettlement Action Plan, Parts A and B.

8.09 Resettlement of families

As described in the previous impact (8.09), from the 226 properties to be expropriated, 138 will be thoroughly affected. Out of these, 110 present residential use.

In the case of the residential properties to be partially affected, it will be possible to relocate them within their same building lots, through indemnities for the construction of additional rooms in compensation for the areas to be demolished.

Concerning the incident legislation (Section 5.2), it is inferred that the dwellers to be resettled shall fit basically into the following types of situation:

- Owners-dwellers who occupy the land regularly, and who will receive a compensation which amounts to the market value of the lot and to the restitution cost of the construction, with the possibility to use it in order to acquire an alternative property.
- Dwellers on land irregularly occupied, whose compensation will be limited to the reconstruction costs only, subject to special assistance in the respective Resettlement Action Plan.
- Tenant-dwellers who shall be resettled and compensated for the loss of accommodation as provided by the Resettlement Action Plan.

I.9 Potential impacts on economical activities:

9.01 Displacement of economic activities along the corridor

The project implementation shall result in the displacement of some commercial activities to alternative places. The activities to be displaced may be divided in two major groups:

- Activities displaced owing to expropriation
- Activities displaced as a function of the indirect effects of the project

In the first case, based on the Census of properties for Part A (concluded) and Part B (in progress) it is estimated that the number of businesses to be fully expropriated will be around 60, with 18 businesses in Part A and 42 in Part B.

It should be considered, nonetheless, that some business owners whose useful area is reduced by the expropriation are likely to choose the relocation to more spacious places.

The displacement of economic activities by the indirect effects of the corridor implementation will happen in many different ways.

As observed in the land use survey of the Directly Affected Area (Section 4.4.1), many businesses bordering the right-of-way use the inner space of this latter. Among these, pubs and restaurants place tables and chairs on the pavement or in lateral streets, especially in shaded areas, as well as other establishments that use public space for merchandise exhibition or even as a product stock area. In this group are included furniture stores, carpentry workshops, building material stores, used car (on-street parking) shops, amongst others.

With corridor implementation, which will occupy most of the right of way, eliminating the possibility of informal occupation, it is probable that most of these establishment owners choose to move out to other road links.

Other economic activities that use the right of way include businesses that rely on kiosks or other permanent facilities which remain on the streets at night.

In this group are mostly sellers of tree seedlings and ornamental plants, which are concentrated in Kimara and in the surroundings of Ubungo Terminal. In addition to these, there are many street vendors scattered around commercial concentration spots along the corridor alignment. Their number is presently smaller since the municipality has decided to relocate this kind of seller from the streets of Dar es Salaam to specially designated markets.

Moreover, along the corridor there are many taxi ranks and daladala parking spaces spread over the empty spaces in the right of way. There are also some parking spaces for construction lorries where the population goes to hire transport services..

All these economic activities shall be displaced as a consequence of the physical occupation of the project right of way.

Lastly, it must be considered that, in some sections of the corridor, where the available road capacity for general traffic will be reduced and/or the on-street parking will be removed, the commercial establishments shall experience a reduction in the business turnover, and this may, in some cases, bring about the decision to move out. It is estimated that this risk is concentrated mainly along the Msimbazi Street branch.

9.02 Reduction of the intensity of commercial activity along the DART during construction

Owing to traffic interruption on DART network, the shops and stores facing the alignments may be affected by the project. In the most critical situations, difficulties in the accessibility may compromise the turnover of clients, implying a reduction of sales volumes and / or services, including a reduction in the staff of such business organizations.

Despite being a temporary impact, it will demand monitoring and specific programmes aimed at the support for the local business, during the construction phase.

I.10 Potential impacts on physical and social infrastructure:

10.01 Disturbance and/or relocation of public utilities

As outlined in the description of impact 8.08, there may be interferences on air and underground utility networks during the construction phase.

All interferences shall be identified and listed in a physical inventory during the executive project phase. The entrepreneur will contact the concessionaire companies responsible for planning the technical procedures related to the relocation and the interruption of supply to public services. The relocation should be adjusted to the construction schedule.

I.11 Potential impacts on public finances:

11.01 Appropriation of part of the public sector's investment capacity

The DART implementation will be funded as follows: 70% of the total investment will be financed by the World Bank, in the form of grants, and 30% by the government of the United Republic of Tanzania.

As a result of such sums of investment, the government will pledge part of its revenue to the public transport sector, reducing, therefore, the availability of resources for investment in other sectors, as for example, health, education, etc.

Although significant, the amount to be invested by the government will be small as compared to the total resources necessary for the implementation of Phase 1. It should be considered, still, the direct and indirect fiscal benefits which will derive, respectively, from the construction and operation of the BRT system.

11.02 Increase in tax revenue during corridor construction

The implementation of DART Phase 1 will demand an investment in the order of US\$ 110 million. Tax revenues will be generated from the construction contracts won by the building contractors.

Complementary tax revenues will come out of the local acquisition of building materials, goods and services.

I.12 Potential impacts on architectural monuments and cultural property:

12.01 Disturbance of architectonic landmarks and other cultural property

The construction phase will directly affect the access to some important buildings and cultural landmarks of Dar Es Salaam. The main buildings to be affected are the many religious buildings located along the entire corridor, but some institutional buildings that will also be directly affected during this period.

The significant areas and/or buildings to be affected during the construction phase are listed in the Section 6.3 (Impact Receptors - Component C.3.08).

6.4.3 Potential Impacts during Operation Phase

Physical Impacts

I.13 Potential impacts on soils and terrains:

13.01 Increased impermeabilization of the right of way

Implementation of the BRT corridor will require additional impermeabilization of the right-of-way.

The intensity of this impact will vary significantly along the BRT alignment. In the Central Business District, additional impermeabilization will not be an issue since the rights-of-way to be used are already practically totally impermeable. On the other hand, along the wider rights-of-way furthest from the Central Business District, significant portions are still impermeable and this condition will be altered, always with more intensity at station locations.

Additional impermeabilization will result in landscape alterations. More importantly, it may imply in alteration in storm water runoff of conditions and as a result may in some cases require adaptation of existing drainage structures. This will require specific hydraulic calculations for verification of altered design flood conditions on all existing drainage structures downstream of areas to be subject to increased impermeabilization. This verification will take place during detailed engineering.

I.14 Potential impacts on air:

14.01 Impacts on air quality during operation

The operation of the BRT system will help improve the air quality in the city of Dar es Salaam, as a result of the rationalization and modernization of the public transport system.

The replacement of many of the “daladala” vehicles, with poor maintenance, by new and less polluting buses, together with the increase in mean speeds on the directly affected roads, tend to promote a reduction in the vehicular emissions, and a subsequent positive impact on air quality, mostly in the areas next to the corridors.

The following table shows the number of kilometers per vehicle type to transport the same number of passengers, current and projected, at the morning peak hour. The DART operation shows there will be a reduction of 19,633 km at the peak hour.

Table 6.4.3.a**Kilometers per vehicle type at the morning peak hour (current and future scenario)**

System Efficiency Indexes peak hour	Current Situation 2008	DART 2008
Veh.Traveled Km Trunk		3,181
Veh.Traveled Km Feeder		3,658
Veh.Traveled Km Daladala	100,566	74,094
Total	100,566	80,933

The next table presents the parameters for the emission of CO, HC, NO_x, SO₂, PM and CO₂ for the above vehicles, in g/km. It was assumed that the emission standards for trunk and feeder buses were the same, corresponding to the model "Euro II". For the daladalas the emission standard applied corresponded to model "pre-Euro I".

Table 6.4.3.b**Standards of pollutant emissions in g/km**

	CO	HC	NO _x	SO ₂	PM	CO ₂
Trunk bus	3	1.7	13	0.013	0.32	1,337
Feeder bus	3	1.7	13	0.013	0.32	1,337
Daladala	20	3.4	21	0.1	1.1	1,408

Source: Environmental Impact Assessment and Mitigation. Draft Final Report. Annex Vol. 8. Dar es Salaam City Council. May/2006.

Lastly, the table below presents the reduction in total emissions at peak hour, based on the reduction of total kilometers covered once the DART system begins operation.

Table 6.4.3.c**Emission of pollutants in g/km, at peak hour, in the current (daladala only) and future (DART) scenarios**

	CO		HC		NO _x	
	Current	Future	Current	Future	Current	Future
Trunk bus	-	9,543	-	5,4077	-	41,353
Feeder bus	-	10,974	-	6,2186	-	47,554
Daladala	2011,32	1481,88	341,924	251,9196	2111,886	1555,974
Total	2011,32	1502,4	341,924	263,5459	2111,886	1644,881

	SO ₂		PM		CO ₂	
	Current	Future	Current	Future	Current	Future
Trunk bus	-	0,04135	-	1,01792	-	4252,997
Feeder bus	-	0,04755	-	1,17056	-	4890,746
Daladala	10,0566	7,4094	110,623	81,5034	141596,93	104324,35
Total	10,0566	7,49831	110,623	83,69188	141596,93	113468,1

The above dataset indicates that the emission of pollutants shall face a substantial reduction with the elimination of the daladala lines. The operation of new buses in the future will result in little increase in total emissions, and all pollutants considered will be at levels lower than the present ones.

The resulting impact on air quality will be quite positive, in view of the current levels of pollution as defined in the IAI diagnosis (Section 4.2.1.5).

Biological Impacts

I.15 Potential impacts on vegetation:

15.01 Increase of urban trees as a result of project landscaping implementation

The implementation of the landscape project of the DART System Phase 1 will result in an increase in the number of trees and gardens within the urban environment.

From the biological standpoint, the larger amount of native trees will provide better conditions for the gene flow of seeds and birds and a wider dispersion of plant species, with positive indirect impacts on birdlife.

At any rate, the most important positive impacts deriving from the implementation of the landscape project will be noticed in terms of the urban population's quality of life.

Socio-Economic Impacts

I.16 Potential impacts on road infrastructure and traffic:

16.01 Permanent alteration of street capacities and local patterns of traffic distribution

With the implementation of exclusive rapid bus lanes along the DART corridors and the rationalization of the public transport system, there will be changes in the street capacities and local patterns of traffic distribution in the DAI.

The ideal standard cross sections as per defined in the project result in total width of 46.5 m along the corridor and 55 m at bus stations. However, as mentioned before in Section 2.1.1, this space is not always available and several design compromises have been adopted along the corridor alignment.

At present, it is observed that in the section of Morogoro Road from Kawawa Road to Ubungu, where the implementation of the ideal standard section of DART is forecasted, the carriageway lacks no physical capacity. The main cause of congestion on this road are the traffic lights at the crossroads. As they operate with four phases, they work as

bottlenecks, compromising the traffic flow. In order to solve this problem, the project recommends the readjustment of intersections through the replacement with two-phase traffic lights and the ban on right turns. In addition, it will be made geometrical adjustments at the intersections, and some barriers will be placed at the end of a few local streets, in a way to drive the traffic flow to U-turns schemes. The segregation of bus lanes will also benefit the traffic reorganization as a whole along this road.

On the other hand, the central section of Morogoro Road, between City Council Station and Bibititi Road, presents a very restricted right-of-way. For this reason, the traffic will be limited exclusively to buses, cyclists and pedestrians. In Section 2 of Morogoro Road, between Bibititi and the United Nations, despite being wider than in Section 1, the right-of-way is still narrow, resulting in a less generous standard-section.

The most critical situation in terms of road capacity is found on Msimbazi Street, a narrow road downtown, with intense business activity. In this case, parking along the kerb will be forbidden, with a view to freeing one lane for the BRT and another for the general traffic.

In other important roads, currently used by many daladala lines, the substitution for micro-bus feeder services and the readjustment of intersections, among other road improvements, will provide capacity gains.

Specifically at the CBD, there is a plan for the reorganization of traffic by means of the assignment of one-way traffic throughout the road network, presently used in both directions.

16.02 Reduction in the availability of external parking spaces

Implementation of the corridor will displace various types of informal uses of the selected rights-of-way. One of the most significant uses to be displaced are parking spaces.

On more densely occupied segments of the Central Business District, implementation of the BRT will reduce already scarce street parking spaces. This will be particularly critical along Msimbazi Street branch where the customers of many of the existing commercial establishments make intensive use of available front-of-shop parking spots.

Along Morogoro and Kawawa Road where the right-of-way is significantly wider, left-over spaces are frequently occupied by taxi spots, daladala resting areas or construction truck parking spots which are known by the population that hires these trucks for construction, moving or other services (see Section 4.4.1). These uses of the right-of-way will no longer be feasible and new parking locations will need to be found.

This impact will affect mostly commercial establishments that depend on availability of parking, taxi drivers, daladala operators and truck owners to be displaced, and customers / users of the services provided by them or by the affected commercial establishments.

However, only in the case of affected commercial establishments can this impact be considered significant and long lasting. In the other cases it is mostly temporary and will cease as soon as adequate alternative locations are defined.

16.03 Permanent restriction to transversal flows of pedestrians

The implementation of the corridor will entail some changes to the pedestrians' transversal flow, mainly because of the streets cross-sections reconfiguration.

The construction of the segregated lanes, plus large stations and terminals along the road can create a visual and physical block, restricting pedestrian crossing in some areas. This can produce impacts mainly in areas of intense circulation of people such as Msimbazi Street, and some parts of the city center.

Along the Morogoro Road, this impact will not be major, since along the first stretch, from City Council to Bibititi Rd, the road will be one-level, and there will be no mixed traffic, and along the second stretch, from Bibititi Rd up to Kimara, the corridor already has the characteristics of a wide road.

Along Kawawa Rd, the existing pedestrian crossing will be reorganized, according to the new signalling and intersections design, and these impacts will occur mainly at stations and the terminal.

Another feature of pedestrian flow that will change is that, today, in many points of the Morogoro Road, the drainage channels are located so as to discipline street crossing. After the implementation of the project, many of these channels will be closed, in order to accommodate the cycling paths and larger sidewalks, and, although crossing will not be allowed, the possibility of crossing out of the recommended areas might increase.

At the main point of circulation, the project proposes the construction of three pedestrian overpasses, providing access to the terminals and feeder stations and also allowing crossing of the road. These overpasses will be accessed by ramps, complying with all the requisites of universal accessibility. The proposed overpasses are:

- Ubungo – at the proposed Ubungo Terminal
- Kimara – at the proposed Kimara Terminal
- Morocco - at the proposed Morocco Terminal

At the other Terminals and Stations, the project calls for bumps, signalling and zebra crossings in order to discipline pedestrian flows.

16.04 Changes in traffic level of streets affected by “daladala” route rationalization

With the beginning of the BRT system operation, many of the existing daladala lines will become extinct, while others will be maintained or relocated, as per the proposed scheme for the rationalization of public transport. Such initiative will promote changes in the traffic volumes on the affected roads.

On the roads where the daladalas operate with considerable demand for passengers, the lines will be replaced by micro-bus feeders, vehicles whose capacity is larger than that of the former. On these roads, the impact on the traffic volumes will be positive, because there will be a reduction in the number of vehicles, and subsequently, less demand for the respective road capacity.

At the Central Business District there is a plan for a complete relocation of daladala lines presently in operation, with the extinction of some and route changes in others. In this case, some roads may experience an increase in the traffic volume due to the concentration of lines. Yet, this will happen only on roads whose capacity can hold such increase, without any damage to traffic flow.

On the remaining road network in town where daladala lines move around with low passenger demand, these shall be preserved.

16.05 Changes in traffic level of streets affected by permanent re-routing of passenger vehicles

The reorganization of general traffic in the CBD streets shall affect the levels of road capacity. In this context, the major impact will happen on Morogoro Road between Sokoine Drive and Bibititi Road, where the traffic of passenger vehicles will be removed.

Notwithstanding, in most of the downtown road network there is a plan for the conversion of lanes into one-way traffic, completely changing the patterns of access and exit. Whilst this shall bring about an increase in the flow of some roads and decrease in others, it is a minor impact, given that the traffic in the central region is already quite heavy and this condition shall not be changed in any case.

16.06 Increase in the level of bicycle use

One of the objectives of the DART system project is to promote non-motorized transport (bicycles and pedestrians).

Almost all standard sections specified in the project will have exclusive cycle lanes, excepting Msimbazi Street and the section of Morogoro Road between the City Council Station and Bibititi Road, where cyclists will be able to move freely on bus lanes.

The promotion of NMTs will constitute a positive impact of the Project, bringing indirect benefits to the general traffic.

16.07 Increase of the barrier effect along the corridor

With the implementation of DART, drivers and pedestrians will face difficulties in crossing the roads where segregated bus lanes are fitted.

The main crossroads will be subject to geometric and traffic light adjustments, in order to eliminate bottlenecks. Some barriers will be put at the end of a few local streets parallel to the corridors, in a way to drive the traffic flow to U-turns and enable crossings only at signalized intersections.

From the viewpoint of pedestrian safety on casualties, the restrictions on crossing and accessibility to BRT from some specific stops with high demand represent a positive impact in relation to the current situation. Alternatively, from the point of view of car accessibility they represent a negative impact, whose intensity, nevertheless, tends to decrease as the motorized population familiarizes itself with the new traffic schemes.

I.17 Potential impacts on public transportation:

17.01 Improvement in the quality and capacity of public mass transport serving the IAI population

This is, concurrently, the main objective and main positive impact of the DART operation.

The implementation of a special physical infrastructure, formed by corridors, stations and terminals aimed at the segregation of many different types of vehicles and to transport hierarchy, together with the concession of the DART operation, which includes the replacement of the current “daladala” by a brand new circulating fleet (articulated buses on trunk lines and micro-buses in feeder services), will result in system rationalization and will increase the capacity of passenger transport.

The final results expected with the implementation and operation of such a system are the increase in users’ mobility, comfort and safety.

17.02 Re-routing and rationalization of “daladala” lines

The rationalization and the change of the remaining daladala routes will not imply a smaller coverage of the public transport service. As analysed in Section 2.4, the level of service of public transport will not be reduced in any of the city’s regions; much to the contrary, it will be expanded in many cases.

Without any service loss, the rationalization of routes shall imply an increase in some users' trip to the nearest line. Likewise, in many cases the rationalization will result in a reduction in the users' walking distance.

Another effect of the rationalization of the remaining daladala lines will be the improvement in the reliability and quality of services, given that, with a smaller amount of lines, frequencies can be reduced.

17.03 Reduction of total bus / kilometers in the IAI

The implementation of the first phase of DART Project will result in a significant reduction in the total number of buses / kilometre covered in the city of Dar es Salaam. On average, the articulated buses on the corridor will cover 44,532 km / day, with a passenger-kilometre index (PKI) of 9,4. Moreover, the micro-buses of the feeder service will cover 51,211 km / day on average, with a PKI of 5,5.

The articulated buses will travel at an average speed of 23 km/h, and the micro-buses in feeder lines at 17 km/h, which make up a total of 4,750 operating hours / day for the whole fleet of the concessionaire operator.

On the other hand, 33 daladala lines will be shut down. In these lines, nearly 460,000 passengers are transported per day at an average speed of 17 km / hour with a passenger / km index (PKI) of 1.2. Therefore, the elimination of these 33 lines will result in a reduction of 26,600 hours / day of daladalas in operation.

Apart from that, in the remaining daladala lines, the total number of passengers / day to be transported will drop to 1,170,000. Assuming that the current average speeds will maintain at 17 km/h with an improvement near of 28% in the PKI as a consequence of the rationalization of such service, it may be estimated that the operation of these lines will result in 56,300 hours / day of daladalas in operation.

From the above it is possible to gather that with the operation of DART Phase 1, the total number of bus hours / day in operation (including articulated buses, feeder micro-buses, daladalas and the remaining modes) will be of 61,100 hours. Comparatively, it is estimated that the present fleet of 5,800 daladalas operates on average 82,900 hours / day.

Consequently, there will be a significant reduction, of nearly 22,000 in the total amount of hours / bus / day in operation in Dar es Salaam.

Similarly, the total amount of buses / km covered per day shall drop from 1,408,000 km/day (exclusively daladalas) to 1,133,000 km / day (considering articulated buses, feeder micro-buses and daladalas, altogether).

The reductions in time and kilometers covered by buses in town will bring about benefits proportional to the traffic flow.

17.04 Reduction of operational costs per passenger / kilometer in public transport along the DART corridor

The overall reorganization of Dar es Salaam's public transport system will provide a substantial increase in the passenger transported / kilometer index (PKI), in addition to the use of modern vehicles with lower operating costs and the rationalization of routes and itineraries.

Such improvements will result in a large reduction in the costs of public transport services per passenger / kilometer in town, assuring, in the medium and long terms, more economical fares to users.

I.18 Potential impacts on urban structure:

18.01 Induction to changes in land use patterns within DAI

In general terms, the mass transport system offers potential for increasing the population density in the area within the influence range of stations (from 300 to 500 m). The increase in accessibility may cause changes in the patterns of land use and occupation in the areas bordering on or next to the corridors.

However, based on the analysis of the urban structure along the DART corridors at Phase I, the areas at DAI where the project would have the greatest potential for promoting changes in the patterns of land use and occupation are those next to the stations planned for the Morogoro Road section along Ubungo e Kimara, where the use, predominantly residential, sprawls in a disperse pattern, among empty spaces. In this section the DART operation may cause the reduction of empty spaces for residential purposes and an increase in the density of built-up areas.

The section between Ubungo and Urafiki is defined by the existence of industries and popular dwellings. It is unlikely that the BRT implementation will cause changes in these already consolidated occupation patterns.

In the section between Morogoro Road between Magomeni and Urafiki (entrance to Mabibo), the project implementation may cause the eviction of people that use the ROW for business and services. The shops and stores existing along this section also use Row for the display of their products, and shall lose this space. There is a potential for vertical development in this section, since the buildings lack the structures or slabs that enable easy building of one or more floors. Quite likely the business owners will promote improvements in the buildings, or possibly sell their outlets. At any rate, there would be no significant impacts on the urban structure.

In the Morogoro Road section between the Msimbazi River and Magomeni there is a steep grade separation between the road and the nearby residential areas, located at a higher level. Even if the carriageway is widened, this configuration will not be changed by the project, so that the gain of accessibility in this section will be most unlikely to cause changes in land use and occupation of the neighboring areas. In addition to the barrier effect, these areas are quite close to the city centre, with consolidated residential use and medium standard constructions in planned plots, different from the residential occupation in the section between Magomeni and Urafiki (entrance to Mabibo), with spontaneous and irregular plots and low standard construction dwellings.

On Kawawa Road between River Sinza and the area neighbouring Kinondoni Road, the border use is predominantly commercial, and the residential occupation along the DAÍ is similar to that in the section of Morogoro Road between River Msimbazi and Magomeni. Between Kinondoni and the Ali Hassam Road neighbourhood there is a vague definition as to the bordering uses, owing to the fact that in recent times Kawawa Road was subject to improvements which resulted in some “open wounds” in the urban fabric, causing land occupation with some institutional uses. It is possible that the DART implementation may promote the consolidation of business and institutional uses, without changing; nonetheless, the residential pattern of DAÍ’s remaining areas.

In the central area it is unlikely that the project will affect the patterns of land use and occupation, since DART will pass through consolidated, chiefly mixed use areas with vertical development. At most there might be some marginal changes in Kaukauna Front area, with the removal of small outlets along the waterfront. The adjacent areas, featuring institutional, commercial and port uses (ferry-boat), will remain as they are. Notwithstanding, it must be observed that the project implementation may serve as an inducement factor in the urban and landscaping improvements to this section.

18.02 Increase in real estate values

The most important contributing factor in the definition of real estate values in cities with market economy is location.

Well located areas are those near tertiary sector centers or sub-centers, where jobs and urban facilities are concentrated (infrastructure and services in general). These areas are occupied by upper class districts. On the other hand, those areas far from these attractive sites and which are badly served by urban infrastructure are the least valued. As a rule, the further and less supplied an area is, the smaller the property prices are, and therefore, the smaller that resident population’s income is.

The implementation of road improvements or the creation of mass transport lines tends, in general, to induce an increase in the property value in the adjacent or nearby areas, owing to an increase in accessibility. This may happen not only in nearby areas but also far from the attractive sites. Road projects that favor individual transport tend to encourage elitism or gentrification, that is, the substitution of families traditionally resident in the areas adjacent to the road works for families with higher incomes or automobile users.

However, in the case of mass transport projects based on buses, the possibility of two different types of increase in property value must be considered:

- The increase in the value of properties immediately adjacent to bus ways, for non-sophisticated, tertiary sector uses (traditional street trading); the shops, stores and services which depend on the turnover of customers, are likewise, less sensitive to the environmental impacts resulting from the changes implemented.
- The increase in the value of properties located in the area directly influenced by the corridor, for residential uses of low and medium standards, as a result of the availability of easy access of users to the transport system.

It should be highlighted that the implementation of bus ways takes place generally on roads that already have commercial corridor features. In such cases, the impact on the value will always be limited, in comparison to the creation of a new bus line for a distant, low-value area, where unused land still exists. Such event may cause a real “leap” in the property values of the affected area.

In the case of the current project, an increase in the property values along all the road links, as per the described trends, is expected. However, in the central area the potential for an increase shall be rather limited, owing to the consolidated occupation. The DART section where the increase in value will be more substantial is on Morogoro Road between Ubungo and Kimara, further from the city centre, and presently less accessible.

18.03 Risk of localized real estate depreciation

This potential impact may be local, in those areas the environmental impact of the BRT system operation are noticed with greater intensity.

The increase in noise levels and the emission of atmospheric pollutants at the terminal and station areas, where a concentration of vehicles and people is expected, may cause a depreciation of some adjacent residential properties.

Aside from that, the implementation of road and landscape improvements and new architectural structures (terminals, stations) along the corridors will tend to minimize or even reverse property depreciation.

18.04 Potential for increased urban density within the DAI

Among the likely results of an increase in population density due to the operation of DART Phase 1 is the occupation of fields and empty lots, on the one hand, and vertical development, on the other. These are both forms of intensification of land use value; nonetheless, whereas the first process implies a concentration of the constructed area, whereas, the second implies the intensification of land occupation potential.

In theory, the increase in density, either through the concentration of the constructed area or through vertical development will have a positive impact. Both provide maximum utilization or social usufruct of the infrastructure and available services along the transport links, contributing to the economy of public resources. The reverse of this process is the centrifugal urban sprawl which promotes an expansion of the urbanized area and subsequently, the necessity to expand the network of public services (see impact 18.04).

In the specific case of the current project, the areas with a stronger probability of an increase in vertical development density are the business and residential areas bordering on Morogoro (as far as Ubungo Terminal) and Kawawa (as far as Ali Hassam Road) Roads. The currently empty areas along Morogoro Road between Kawawa Road and Kimara may experience an increase in land value and land fragmentation.

18.05 Increased potential for radial expansion of the urbanized area

Another likely effect of roadworks and the implementation of the BRT systems is an increase in the potential for centrifugal urban sprawl.

This inducement potential is a natural consequence of an increase in accessibility to certain areas in town. With the reduction of travel times in the downtown-uptown radial trips, the relative distances decrease, in a way that new areas, formerly relegated to a second plan by the market, become part of processes such as land fragmentation and increase in property value.

In large cities of third world countries, where historical urban structures have taken on an essentially radial organizational configuration of the downtown-outskirts type, the implementation of the BRT systems has no power to change the urban reality defined by market rules. This is determined by the fact that the poorest population lives, as a rule, in districts where real estate and rents are cheaper, far from the central business district. The so-called 'infinite growth of urbanized area' model, although capable of providing the poor with conditions of access to housing (regardless of the quality of human settlements), has proven to be costly to public funds, because it requires the continuous expansion of networks and public services and demands high maintenance costs.

Differential increases in accessibility may worsen this trend, encouraging a rise in property prices and rents in some of the districts now served by more efficient transport systems.

This could result in the eviction of those families who cannot afford the new housing costs, to places even farther or more peripheral to the city centre.

As already mentioned, with the implementation of DART Phase 1, such impact along Morogoro Road link, between Kawawa and Kimara, where there are still many empty spaces may occur.

Such effects can only be compensated by social and urban policies complementary to transport sector policies which allow families to stay put, or else policies that offer low cost dwelling units in locations, fairly served by transport, services and jobs.

In this context, the development of new tertiary sector sub-centers is a policy recommended to reduce the population's functional dependence on the jobs offered in the traditional CBD. Such a measure, though, cannot be exempt from the previously mentioned policies, since the development of sub-centers can also trigger an increase in property values and the eviction of lower income families.

18.06 Development of new urban sub-centers or expansion of existing ones

The corridor implementation can encourage significant urban and economic development along Morogoro and Kawawa Roads and Downtown, creating new hubs and triggering the development of other areas. The urban landscape can be improved by the application of other concepts of urban space use, since the corridor will promote changes predominantly in its area of influence.

The implementation of Phase I of the corridor makes possible the development of certain areas, inducing the creation of leisure and social activity facilities. Seven (07) important urban hubs along the proposed First Phase DART System that can be enhanced by its implementation can be identified:

- Hub 1 – Kivukoni Front, including the Fish Market and the Water Front. The impact of the implementation of the Kivukoni Terminal, near the Fish Market, and the new landscape and reconfiguration of sidewalks along the waterfront, can induce new investments along this area, which has great potential for leisure and tourist activities, due to the existence of major hotels and the proximity of the port.
- Hub 2 – Central Business District, including City Council, Samora Avenue, and Libya Square – The implementation of DART can bring new investments to these areas and the reorganization of its business characteristics will require also the reorganization of public space.
- Hub 3 – Kariakoo - Kariakoo area is a market activity area. The Terminal will be located on the extreme south of this area and can serve to organize public areas,

integrating the activities that were displaced by the removal of the street vendors that were occupying the area.

- Hub 4 – Magomeni - The intersection of Kawawa and Morogoro is one of the major road network nodes in the City. With the implementation and expansion of the System, this importance will increase, and the area will become a significant hub for the whole city. This is also true of Magomeni Market, which can be enhanced thanks to its proximity to the Magomeni Mapipa Station.
- Hub 5 – Morocco - The Morocco Terminal is an major transfer point of the DART System. For this reason, it may become an attractive location for businesses, especially for services and small shops.
- Hub 6 – Ubungo – This is an important point for the transportation system in Dar Es Salaam. It is strategically located near the junction with Nelson Mandela/Sam Nujoma Rd and it encompasses the present Upcountry Terminal. This is a potential area for the development of mixed activities, and can be converted into a focal point of the city.
- Hub 7 – Kimara – Due to the implementation of a Terminal, this area can be enhanced by the creation of new businesses and the development of existing ones.

I.19 Potential quality of life impacts:

19.01 Reduced travel time for corridor users

One of the main benefits of the implementation of DART system will be the reduction in travel times. This will arise mostly from:

- the implementation of a suitable road infrastructure, which will enable the segregation of different types of traffic (including cycle lanes), and intersection adjustments, mostly for the reduction in waiting time at traffic lights;
- the construction of terminals and stations for transfers, and the implementation of an integrated fare system;
- the valorization of a public transport system, with the use of high capacity buses in the trunk lines and medium capacity micro-buses in the feeder services (feeders), as well as the organization of the daladala lines;
- an incentive to non-motorized transport systems (NMTs), such as bicycles.

The first two improvements will enable an increase in the mean speed of buses on the project roads to an average of 23 km/h. The second two aim at facilitating / speeding up transfers in the trips between different transport modes (walking, bicycles, daladala, micro-buses and articulated buses).

As compared to the present situation, characterized by the low of capacity of the daladala systems to respond to the rising demand, the implementation and operation of the DART system will provide a significant reduction in the downtown-uptown travel times, benefiting not only public transport users, but also the motorized population due to traffic segregation and the bus stops.

Simulations show that the current daladala travel time amounts to 4,269,917 minutes. The DART system operating at the morning peak hour, by articulated bus will be 3,910,685 minutes, which is equivalent to time savings of 2.6 minutes per trip, or 98,840,119 minutes per month. As to the overall time, which includes in-vehicle, fare payment, walking to the station and waiting time, the average economy per trip will amount to 1.3 minutes per trip, equivalent to 49,242,000 minutes per month, for the whole system.

19.02 Alteration of total cost of travel for corridor and feeder line users

The management of the public transport system in Dar es Salaam will be granted as a concession to a private company, whose revenue shall derive from the collection of fares.

It is therefore expected that the operation of a modern and more efficient transport system will necessitate ticket prices higher than the fares currently charged by the daladala operators. Nevertheless, this price will have to be based on the average users' income possibilities, so that the running of the service becomes economically feasible.

Moreover, as described above, there is plan for the adoption of an integrated system between the trunk lines and feeder services in order to establish a unified system of fares at terminals and stations. The purpose is to provide a reduction passenger time at transfers and an overall economy of total travel time.

The beginning, the DART operation shall gradually introduce the population to the gains in the cost-benefit relationship, reducing the likely impact of the initial rise in transport fares. The overall consideration being that the increase in users' mobility represents, in theory, more available time for the practice of other profitable activities.

19.03 Reduction of total direct employment necessary for operation of the public transportation system of the IAI

The modernization and reorganization of the public transport system in Dar es Salaam will constitute a social negative impact in the reduction of operational people employed.

The current demand data shows that the daladala fleet in operation amounts to 5,800 vehicles, with a total of 11,600 employees (drivers and conductors) per shift. Taking into account a two-shift operation, with one driver and one conductor per shift, the total number of employees amounts to 23,200.

After the elimination and relocation of lines, the remaining daladala fleet will drop to 4,380 (including the spare fleet). Considering a two-shift operation, with one driver and one conductor per shift, the following shall prevail:

- 1,420 vehicles will be taken out of operation;
- 5,680 drivers and conductors will lose their jobs.

According to data shown in Section 2.7, it is estimated that DART Phase I operation will generate a total of approximately 2,100 jobs. A significant part of these jobs may be filled by daladala drivers and fare collectors. However, many will need to seek other employment as a result of DART Phase I implementation. A specific program will seek to mitigate this impact ("Programme for the Compensation of People Involved in Daladala Operation" - Section 6.5, P.13) by assisting affected drivers and fare collectors with training and other income restoration strategies.

19.04 Increase in the potential for employment generation in the DAI as a result of increased density

The increase of land occupation density, caused by the operation of the DART system, may bring about a rise in the potential for job generation. This is a potential indirect impact arising out of impact 8.04, as the population increase at DAI tends to boost business and services, benefiting the urban economy as a whole. The simple fact that there are more people living or moving around DAI represents a potential economic advantage and rise in salaries, which can contribute, accordingly, to the improvement in the quality of life of the population directly affected.

19.05 Disturbances to local population as a result of commercial activity displacement

Local consumption patterns will have to be altered as a result of the displacement of a significant amount of commercial activities, particularly along certain segments of the DART Phase I alignments. Consumers who will have to alter their consumption patterns will find new alternative suppliers of goods and services and will need to adapt to a significantly altered distribution of commercial activity within some neighborhoods.

This impact will be more intense during construction and initial phases of project operation. However, it can be considered an impact of lesser importance in the global context, since alternative suppliers of goods and services will be rapidly selected by consumers in most cases.

19.06 Local alteration of noise level during operation

During the operation of the DART system there will be changes in noise levels along the corridors and on DAI local roads.

On the corridors and at the intersections the traffic-light adjustments (decrease in the number of phases) will reduce congestions, so that vehicles will travel at mean speeds higher than the current ones. As motors turn for longer periods at higher rotation bands, the levels of noise emission will tend to a decrease.

In some sections of DART, such as on Msimbazi Street, there will be no significant change in the noise levels, since there are several daladala lines circulating there. Despite the substitution of such services by high capacity buses, with less frequency and fewer stops, the latter will continue to produce higher noise levels.

On the remaining DAI roads changes in the noise levels will result from the relocation of general traffic and daladala lines. Local residential streets, presently with little traffic, may be affected by an increase in vehicles, and in turn, the noise levels. On the other hand, roads with currently intense daladala traffic may benefit from the reduction or extinction of lines, as well as from the introduction of micro-bus lines (feeder services).

Broadly speaking, the most sensitive recipients to vehicle noise are schools, hospitals and residential areas quoted in the description of impact 8.07. As the ROW along Morogoro Road is wide, the landscape project shall include green areas aimed at reducing the level of noise. A similar measure may be applied to the area surrounding the Ubungo Terminal and the existing hospital.

19.07 Landscape alteration and urban requalification of areas adjacent to the corridor

After the end of the execution of DART Phase 1 and the implementation of the landscape project, the configuration of road links directly affected will have their landscape positively changed to the betterment of the general urban aspect of the area.

Such modifications will include the restoration of pavements, fitting of new structures (stations, terminals), cycle lanes and new urban fixtures, as well as an increase in trees and urban gardens. These improvements tend, in turn, to encourage the revalorization of public areas and buildings, currently run-down or degraded by the intense vehicle and pedestrian traffic.

On the other hand, it is possible that some open spaces planted with trees and currently used by the population as leisure areas may be eliminated or partially affected by the widening of the carriage sections.

A project for a high capacity transport system cannot be seen as a sector project. Indeed, urban plans and schemes shall be ordered by the City Council so as to intensify the project's positive aspects and to avoid negative ones.

19.08 Alteration in the number of traffic accidents

Some previous experiences of corridor implementation have shown that there is the possibility of an increase in the number of accidents involving pedestrians, buses and mixed traffic, at least in the first months after implementation. This is due to the fact that both pedestrians and drivers have to get used to the new configuration of traffic speed and signalling, especially in the cases of buses, which will operate in segregated lanes.

Such an impact, however, can be considered to be provisional and it is expected that after an initial adjustment period the level of accidents will decrease below the present rate.

I.20 Potential impacts on economic activities:

20.01 Induced change in commercial and service activities along the corridor

The start of the operation of the DART system tends, in theory, to increase the value of the areas bordering on the roads affected, for tertiary sector uses. The infrastructure, road and landscape improvements may constitute incentives, for the owners of business facilities along the corridor, to renovate and/or expand their buildings, or to transfer their outlets to other parties interested in the investment.

20.02 Increased potential for retail shops and service providers in the areas surrounding stations and terminals

Due to the concentration of people, the areas within the range of accessibility to stations and terminals (from 300 to 500 m) may become particularly interesting for tertiary sector uses.

Notwithstanding, the stations and terminals specified in the project are already located in places meant for public transport users. They contain daladala stops and concentration of people, business and service activities. Furthermore, as the project specifies the construction of business and service outlets within the terminals, part of the potential for the development of new business facilities will be absorbed by this supply.

As a result of these aspects, major changes, such as significant changes to the commercial pattern or changes to the types of activities existing in the surroundings of stations and terminals are not expected. The possibility of substitution of residential uses by commercial uses in some real estate units should not, however be excluded.

20.03 Potential income loss for daladala operators

The implementation of the DART system is concerned with the rationalization of the whole public transport system currently under operation, including the elimination of several daladala lines. One potential negative impact of the project is the loss of jobs and sources of income for drivers and conductors.

Presently the daladalas perform 41,100,000 trips per month. Once the DART system begins to operate, the articulated buses and feeders will perform 11,200,000 trips, reducing the amount of daladala trips to 30,000,000 per month (reduction around 28%). This reduction will cause the elimination of approximately 5,680 jobs, as per described in Impact 19.03 description.

1.21 Potential impacts on physical and social infrastructure:

21.01 Increase in the serviced area of key components of local social infrastructure

The operation of the BRT system will increase the users' mobility and there will be an indirect expansion of the area covered by some social services existing at DAÍ. In other words, it will be easier and faster for people living in areas previously very far from social services to now have easy access to such facilities.

Most of the social services of interest for the system users (schools, religious buildings and hospitals) are located in the central area, in the surroundings of Kivukoni Front and in two sections of Morogoro Road: between Bibititi Road and River Msimbazi, and between

Kawawa Road and Kagera Street. There are also many schools and some religious buildings located at DAI along Kawawa Road.

I.22 Potential impacts on public finances:

22.01 Indirect increases in property tax revenue as a result of real estate value increases and intensification of economic activity along the corridor

An indirect effect of the implementation of the DART system, is the expected increase in property values and the boost to economic activities at DAI, mostly in the areas surrounding the terminals and stations. This process tends to promote a gradual increase in the tax revenues on real estate, supported by the Dar es Salaam City Council.

6.5

Environmental and Social Mitigation and Management

The measures for the prevention and mitigation of impacts aiming at the socio-environmental management of the Project were grouped in Programmes.

The planned objectives and measures are described below for each Programme, according to the specific level of detail, together with the phase of application and the stakeholders in charge of the implementation.

P.01 Programme for the Environmental Optimization of the Executive Project

- Phase: planning
- Stakeholder in charge: design companies and environmental specialists

The purpose of the environmental optimization programme of the DART system executive project is to assure the participation of environmental specialists in assisting the design companies to adjust the geometry and other aspects to the objectives of mitigating and minimizing the social and environmental impacts.

The environmental specialists must be consulted about a wide variety of aspects of the executive project, with a view to incorporating specific preventive measures, such as:

- Geometric adjustment of the corridor alignment to minimize expropriation and demolition and the clearing of large-sized trees.
- Detailed study about the location and implementation of stations and terminals, in order to guarantee the selection of areas without environmental constraints (for example, the existence of major plants, nearby watercourses and soil highly prone to

erosion) and provide Dar es Salaam's population with maximum transport functionality;

- Detailed study about the integration points between the trunk lines and the feeder services, based on the previous transport demand study (survey of travel demand and daladala users' concentration points);
- Strengthening of road capacity in the sections where the ROW enables carriageway widening, in order to reduce the impact on mixed traffic and thus provide ideal operational conditions for the BRT;
- Adaptations at the intersections, including adjustments to the geometry and to traffic-lights (reduction in the number of phases, synchronization), in order to increase in the corridor mean speeds, especially for the buses;
- Rationalization of crossings and pedestrian flow in order to provide them with safety and reduce the casualty rate;
- Project to adapt the urban drainage system, to increase the surface run-off along the corridor, to eliminate the bottlenecks of the transverse and lateral culverts, and to substitute the existing gutters by buried concrete drain pipes;
- Planning for the relocation or replacement of interferences (networks of air and underground utilities) along the alignment, together with public companies and / or the concessionaires in charge;
- Integrated project on signaling and visual communication to provide better safety conditions for drivers and pedestrians, and to inform users about the location of public equipment (stations, terminals) and the available bus lines;
- Landscape project in the free areas along the corridor and next to the terminals, to maximize green space, the permeable areas and urban tree planting.

P.02 Programme for the Environmental Control of the Construction

- Phase: construction
- Stakeholder in charge: hired building companies

The programme aims to assure the environmental management of construction by the application of a series of measures for the adjustment to building procedures so that the works be executed with the greatest degree of environmental, social and occupational safety care.

A series of mitigation measures will be specified in the invitation to bid for the roadworks, and included in the annex of the contractual documents, in order to guarantee their correct implementation.

Among the executive aspects subject to the environmental control measures to be carried out by the building contractor, the following must be emphasized:

- Cleaning and organization of the construction sites and working faces;
- Workers' code of conduct;
- Workforce training in environmental issues;
- Procedures for intervention in third party areas;
- Sanitary facilities at the construction sites;
- Signaling and delimitation of the working faces;
- Controlled execution of the vegetation clearing;
- Erosion and soil run-off control;
- Operational control of the exclusive support areas (send-off and borrow-pit areas, asphalt and concrete mixing plants), or the operational supervision of the outsourced support areas;
- Noise level control at the working faces;
- Dust suspension control on the roads affected by heavy duty traffic, at the building contractor's service;
- Demolition control;
- Management of construction debris;
- Management of the relocation of air and underground interferences;
- Adjustment to the schedule of works for minimizing interferences with local traffic;
- Planning and rationalization of local road use;
- Procedures for the close-down of works.

P.03 Programme for Occupational Health and Safety during the Construction

- Phase: construction
- Stakeholder in charge: hired building contractor

The main objective concerning work safety and occupational health during the construction is to enable the building contractor to work within the specified legislation to assure that safety working procedures be adopted wherever there is risk, and control that the working environment meet the quality standards of hygiene and ergonomics.

The planned measures in this programme will correspond to the rules and procedures specified in "The Occupational Health and Safety Act" (The United Republic of Tanzania, N° 5 OF 2003). Among the main aspects to be met by the building contractors, the following must be highlighted:

- Elaboration of internal rules and procedures related to occupational health and work safety;
- Delegation of powers and internal control functions of the working environment to health and safety experts;
- Creation of Safety and Health Committees;
- Admission medical examinations;
- Training and supervision of workers in the adoption of procedures for safety work by type of activity;
- Provision of individual and collective protection equipment and first aid kits;
- Suitable sanitary and ergonomics conditions in the working environment;
- Records and notification of accidents and occupational illnesses;
- Conservation of / update on the record entries for the Public Administration inspection.

P.04 Programme for the Environmental Inspection of the Construction

- Phase: construction
- Stakeholder in charge: entrepreneur (Dar es Salaam City Council)

The entrepreneur shall be directly in charge of the programme for the environmental inspection of the construction, which will rely on the support of companies specialized in environmental management. Through this programme it will be possible to run a routine for the supervision, monitoring and environmental record of works, including the systematization for the management of observed non-conformities in compliance with the remaining environmental programmes.

Other principle measures planned for this programme are as follows:

- Environmental inspection of works;
- Environmental documentation of works;
- Management of permits and complementary permissions;
- Precautionary building inspections;
- Monitoring of noise during construction;
- Monitoring of particulate matter during the construction;
- Coordination of the interface between the environmental authorities during the construction;
- Assistance with and investigation into the community's complaints;
- Implementation and operation of the non-conformity management system.

P.05 Programme for Traffic Management during the Construction

- Phase: construction
- Stakeholder in charge: entrepreneur (Dar es Salaam City Council)

The purpose of this programme is to define the procedures for the management of temporary changes in the local pattern of traffic flow during the construction phase. The particulars of the programme are in **Annex 10**, which deals with traffic displacement, concerning Part A of the roadworks. The programme for Part B shall follow the same procedures.

P.06 Programme for Social Communication

- Phases: planning and construction
- Stakeholder in charge: entrepreneur (Dar es Salaam City Council)

The objective of the social communication programme is to provide all the stakeholders with pertinent information about the project. This broadly based and focused information will be made available during the phases of planning and construction.

Among the planned measures are the following:

- Disclosure of works and physical schedule of execution, in the planning phase;
- Disclosure of the traffic interferences, in the phases of planning and construction;
- Previous communication about public service interruptions, during the construction phase;
- Creation of a community information centre, for the collection of complaints

All the measures of social communication related to the procedures of indemnification, resettlement and social compensation for the people affected by the project belong to a specific programme (see following programme).

P.07 Programme for Indemnification and Resettlement

- Phase: construction
- Stakeholder in charge: entrepreneur (Dar es Salaam City Council)

This programme consolidates all measures related to the management of the expropriation processes in the area to be occupied by the DART system roadworks, assuring compatibility of areas to be released with the requirements of the construction schedule. In addition to those directly affected by the expropriation and indemnification processes, people who do not own real estate, but who shall somehow be affected by the project, will be entitled to claim some type of support or compensation.

The particulars of the measures relative to this programme will be incorporated in a Resettlement Action Plan, specific for Parts A and B of Phase 1. These two plans fit into the guidelines defined in the Resettlement Action Plan for Phase 1. All these plans are stand-alone documents and are not detailed in this ESIA.

P.08 Programme for Local Business Support

- Phase: construction
- Stakeholder in charge: entrepreneur (Dar es Salaam City Council)

The programme for local business support is to implement strategies to minimizing the interferences in business and services volumes during the construction stage, and provide assistance with occasional changes in land use / substitution of business activities.

Whereas it is expected that the total volume of economic activities along the corridor will increase once the system is operational, the programme for local business support will include measures to ensure that traders currently in the corridor will be included in this future development.

The main measures planned for the programme are as follows:

- Minimization of interruptions and/or access restrictions during the construction;
- Location / availability of parking spaces for customers;
- Assistance with changes in land use;
- Marketing of sales;
- Purchase of input materials / services;
- Programme for staff replacement;
- Right of preference in new commercial spaces along the corridor and / or in neighbouring projects;
- Right of preference in commercial spaces in public areas.

In the event of substantial income losses or business disruption due to access interruptions and other construction interferences, the Resettlement Action Plan entitles the business owners to file for financial compensations.

P.09 Programme for the Environmental Education

- Phases; construction and operation
- Stakeholder in charge: entrepreneur (Dar es Salaam City Council)

The programme for environmental education shall be directed at owners and employees of business facilities bordering the corridor, families and households along the corridor, concessionaire operators of commercial spaces within the corridor, students within the DAI and users in general.

The purpose is to raise these groups' awareness of the importance of cooperation in the management of public spaces. The spaces can either be connected to the corridor or to adjacent areas subject to future developments. Among the topics to be discussed in the environmental education activities are the following issues: waste collection, generation of refuse, basic sewage, conservation of green areas and other relevant subjects.

The awareness / environmental education activities may be carried out through marketing / advertising material (for example, at stations and terminals) and specific sub-programmes (for instance, programmes for selective waste management involving terminal employees, and programmes for sanitary education, at the markets).

P.10 Programme for Urban Requalification

- Phase: operation
- Stakeholder in charge: entrepreneur (Dar es Salaam City Council)

A transport system project cannot be dealt with as a sector project. This programme aims at requalifying the urban spaces along the corridor and the areas surrounding the stations and terminals.

The processes of urban requalification along transport corridors involve the definition of guidelines for the transformation of urban spaces, including proposals for changes in the zoning legislation and urban indicators (land use, occupation, density, templates), incentives for the restoration of buildings of historical and cultural interest, regulation of tertiary uses, creation and requalification of public spaces (squares, pavements, gardens) and provision of parking spaces, amongst other aspects.

As the processes of urban renewal involve the participation of many actors, public and private, and take some time to mature, the City Council may boost the first transformations through the release of a pilot-project for a special interest area in town, for instance, the CBD area. One possible initiative is to promote an open competition for ideas and proposals from architects and urban planners. The winning proposals would be discussed with the population. , ,

P.11 Programme for the Operational Integration in the Corridor

- Phase: operation
- Stakeholder in charge: entrepreneur (Dar es Salaam City Council)

The objective of the programme for the operational integration in the corridor is to optimize the complementary relationship between the trunk line and the feeder services, and to boost intermodal transport with non-motorized transport (bicycles, pedestrians). A partial list of measures for this programme is presented below:

- Rationalization and displacement of feeder services;
- Implementation and operation of cycle parking facilities;
- Incentives to construct car parks next to stations and terminals.

P.12 Programme for the Compensation of Business owners for the Loss of Parking Spaces in the CBD

- Phase: operation
- Stakeholder in charge: entrepreneur (Dar es Salaam City Council)

The purpose of this programme is to provide business and service owners with compensations for the likely loss of parking spaces along the corridors. The impact will be particularly strong along Msimbazi Street, where some 800 parking spaces shall be eliminated.

Although the cross streets may compensate, to a certain extent, the loss of parking spaces in the corridors, the City Council may encourage the use of empty building lots as car parks and the construction of garage-buildings.

P.13 Programme for the Compensation of People involved in the Daladala Operation

- Phase: operation
- Stakeholder in charge: entrepreneur (Dar es Salaam City Council)

The objective of this programme is to provide daladala drivers and conductors with compensation for loss of jobs and income.

For this purpose, it will be necessary, initially, to organize a census of those affected, since operators are hired by companies or work as free-lance or independent. The claimants shall prove their status as operators of daladala lines liable to elimination. Cooperatives of daladala operators shall participate in this application process.

Some compensatory measures can be recommended to minimize the impact from the loss of jobs:

- Inclusion, in the invitation to bid for the DART concession, of a clause specifying the bid winner's duty to hire people working in the daladala lines made extinct;
- Participation of cooperatives of daladala operators in the profit share earned by the DART operating company;
- Inclusion of the affected people in training programs and courses for professional requalification.

P.14 Programme for the Decontamination of Environmental Liabilities

- Phases: construction and operation
- Stakeholder in charge: building contractor and entrepreneur (Dar es Salaam City Council)

Much as the decontamination of soil and underground water in petrol station areas is the respective owners' duty, the building contractor in charge of the roadworks shall designate an area technically and environmentally suitable for the disposal of contaminated material. Currently there is no such area in Dar es Salaam.

This programme intends to take advantage of the removal of fuel facilities at petrol stations as an opportunity for the creation and regulation of a methodological framework for the survey and monitoring of contaminated areas in town.

7.0

Conclusions

When fully implemented, the DART BRT system will alter the face of Dar Es Salaam. The current chaotic system of daladalas will be substituted for modern and efficient buses operating on a network of segregated bus lanes where passengers will be able to reach most of the city at average speeds far higher than those currently achieved.

Phase I of the project, which is the object of this Environmental and Social Impact Assessment, will advance significantly towards this goal. The project's main benefits will include reduced travel time of users, reduced public transportation costs and therefore reduced future price pressure on tariffs, improved general traffic flow, reduced air emissions and corresponding air quality improvements, and improved urban landscape and quality of services at locations where project-induced re-qualification of public open spaces will proceed.

On the negative side, the most significant project impacts will affect the socio-economic environment, rather than physical or biological environmental components.

In effect, direct and indirect displacement of people and economic activities is by far the project's most significant impact. Nonetheless, the extent of displacement will be quite limited. In total, it is expected that DART Phase I will result in resettlement of 78 families (either owner-occupiers or tenants) and approximately 60 businesses. An additional amount of businesses which will lose clientele as a result of reduced access or lost parking, or which will no longer be able to make informal use of the public right-of-way, is likely to be displaced as well.

Current daladala operators (businessmen, drivers and fare collectors) will be impacted by loss of business volume and loss of employment. Part of this impact will be compensated through employment in the DART system. Furthermore, some form of participation of daladala operators in the project's benefits is currently in planning stages.

Since the project is located in an urbanized context along established commercial corridors, impacts on native vegetation and fauna will not be significant. Only urban landscaping vegetation will be affected and this effect will be compensated in the long run when landscaping implemented as part of the project consolidates.

Physical environment impacts are also expected to be of marginal importance. Necessary earth movement is limited and local topography implies in limited risks of erosion and soil run-off. Commercial borrow pits for all construction materials are available at reasonable (although not always ideal) distances from construction fronts and no new pits or quarries will need to be developed. Only two (02) flood plains will be intercepted by Phase I corridors and widening of existing avenues will be limited and is not likely to imply in significant impacts.

Therefore, it can be stated that DART Phase I benefits are far larger than its impacts and will positively affect the majority of Dar Es Salaam's population.

Negatively affected peoples will receive due compensation and assistance through the project's Resettlement Policy Framework that provides the basis for preparation of Resettlement Action Plans and definition of compensation packages.

8.0

List of References

BLACKSMITH INSTITUTE. Available: <<http://www.blacksmithinstitute.org>>.

COOPER, C. D.; ALLEY, F. C. **Air pollution control: a design approach**. 2nd. Edition. New York: Waveland Press. Inc., 1994.

FIDDED, D. **The prediction of storm rainfall in East Africa**. Crowthorne: Department of the Environment / Transport and Road Research Laboratory, 1974. TRRL Report 623.

_____.; FORSGATE, J. A.; GRIGG, A. O. **The TRRL East African flood model**. Crowthorne: Department of the Environment / Transport and Road Research Laboratory, 1976. TRRL Report 706.

LINSLEY, R. K.; KOHLER, M. A.; PAULHUS, J. L. **Hydrology for engineers**. New York: McGraw-Hill, 1958.

MBULIGWE, S. E.; KASSENGA, G. R. Automobile air pollution in Dar es Salaam City, Tanzania, **The Science of the Total Environment**, v. 199, n. 1997, p. 227-235, 1997.

MBULIGWE, S.; KASEVA, M. **Pollution and self cleansing of an urban river in a developing country: a case study in Dar es Salaam, Tanzania**. New York: Springer, 2005.

MOHAMED, S. M. **The assessment of water quality and pollution in Tanzania**. Dar es Salaam: University of Dar es Salaam Printing Press, 2000.

NELSON, S. A. **Streams and drainage systems**. 2003. Available: <<http://www.tulane.edu/~sanelson/geol111/streams.htm>>.

SUSTAINABLE DAR ES SALAAM PROJECT – SDP. **Air quality monitoring in Dar es Salaam City**: report. Dar es Salaam, 1997.

TANZANIA NATIONAL ROADS AGENCY – TANROADS. **Feasibility Study and Preliminary Engineering Design of Singida Shelui Road Section: final report on Environmental and Social Impact Assessment (EIA and SIA) and Resettlement Impact Assessment (RIA)**.

THAGESEN, B. **Highway and traffic engineering in developing countries**. London: E & FN Spon, 1996.

Legislation

- Environmental Management - Act of 2004.
- Water Utilization and Control - Act of 1974 (amended by Act n. 10 of 1981 and Act of 1997).
- Water Quality Standards: the water quality standards have been established under the Water Utilization (Control and Regulation) - Amendment Act n. 10 of 1981).
- Local Government - District and Urban Authorities - Acts of 1982.
- The Forest - Act of 2002.
- Fisheries Regulation of 1989.
- The Public Recreation Grounds Ordinance – Cap. 320.
- The Township Building Rules – Cap. 101.
- The Land Acquisition - Act n. 47 of 1967.
- The National Investment - Act n.10 of 1990.
- The National Land use Planning Commission - Act n.03 of 1984.
- The Local Government: Urban Authorities - Act n. 08 of 1982.
- The Land - Act n. 04 of 1999.
- Land Acquisition - Act n. 47 of 1967.
- Land - Act n. 04 of 1999.
- Village Land - Act n. 05 of 1999.
- Complementary regulations issued in 2001.

DART Technical Reports

LOGIT ENGENHARIA CONSULTIVA LTDA.; INTERCONSULT LTD. **Executive Summary**. Dar es Salaam, Tanzania, oct. 2006. v. 1.

_____. **Background on public transportation**. Dar es Salaam, Tanzania, dec. 2006. v. 2.

_____. **Field surveys and data collection**. Dar es Salaam, Tanzania, dec. 2006. v. 3.

_____. **Demand modeling and forecasting**. Dar es Salaam, Tanzania, dec. 2006. v. 4.

_____. **DART operational design**. Dar es Salaam, Tanzania, dec. 2006. 2 v. (v. 5).

_____. **General roadway design**. Dar es Salaam, Tanzania, dec. 2006. v. 6.1.

_____. **Station design**. . Dar es Salaam, Tanzania, dec. 2006. v. 6.2.

_____. **Terminals design**. Dar es Salaam, Tanzania, dec. 2006. v. 6.3.

_____. **Bus depot design**. Dar es Salaam, Tanzania, dec. 2006. v. 6.4.

_____. **Urban renewal proposal**. Dar es Salaam, Tanzania, dec. 2006. v. 6.7.

_____. **Traffic analysis and intersection design**. Dar es Salaam, Tanzania, dec. 2006. v. 6.8.

_____. **Materials report**. Dar es Salaam, Tanzania, dec. 2006. v. 6.9.

_____. **Cost estimated for physical infrastructure**. Dar es Salaam, Tanzania, dec. 2006. v. 6.10.

_____. **Fare collection system**. Dar es Salaam, Tanzania, dec. 2006. v. 7.1.

_____. **Bus technical specifications**. Dar es Salaam, Tanzania, dec. 2006. v. 2/2. (v. 7.2).

_____. **Traffic management impact and mitigation**. Dar es Salaam, Tanzania, dec. 2006. v. 8.1.

_____. **Parking impact analysis and mitigation**. Dar es Salaam, Tanzania, dec. 2006. v. 8.2.

_____. **DART economic evaluation**. Dar es Salaam, Tanzania, dec. 2006. v. 8.3.

_____. **Implementation plan**. Dar es Salaam, Tanzania, dec. 2006. v. 9.

Contacts

Dar es Salaam City Council

Tanzania Telecommunication Company Ltd. - TTCL

Tanzania Electricity Supply Company Ltd. - TANESCO

Dar es Salaam Water and Sewerage Authority - DAWASA

Road Improvement Project (DRIP) by M/S Konoike Construction Co Ltd. of Japan

Skamphil Colas Ltd of Denmark

Institute for Transportation and Development Policies - ITDP



ANNEXES

Annex 1 – List of Consulted PAP's

Annex 2 - Intersections

Annex 3 – Materials Sourcing Technical Data Sheets

Annex 4 – Articulated Bus and Feeder Bus Illustrations

Annex 5 – Current and Proposed Routes for IAI Daladala Services to be Re-routed

Annex 6 – Vegetation Photographic Report

Annex 7– DAI – Land Use Identification

Annex 8 – DAA – Land use Identification

Annex 9 – Land Use Photographic Report

Annex 10 - Traffic Management During Construction



List of Consulted PAP's

Serial Number	Name	Position
1	Mr. Sam Swila	Ward Executive Officer-Kivukoni
2	Mr. Ndaro, J.C.P	Ward Executive Officer-Mchafukoge
3	Mr. Kilo, Y	Ward Executive Officer-Kisutu
4	Ms. Rehema D. Mkumbo	Ward Executive Officer-Upanga East
5	Ms. Mwangwale, H	Ward Executive Officer-Upanga West
6	Mr. Abdu R. Msangule	Ward Executive Officer-Jangwani
7	Mr. Amani H. Kafugugu	Ward Executive Officer-Magomeni
8	Ms. Elizabeth E. Mbalale	Ward Executive Officer-Ndugumbi
9	Mr. Mohamed A. Bwamkuu	Ward Executive Officer-Mzimuni
10	Ms. Elizabeth Kijo	Ward Executive Officer-Makurumula
11	Mr. Bryceson K. Mwangomo	Ward Executive Officer-Manzese
12	Mr. John Mwerange	Ward Education Officer-Manzese
13	Ms. Mwajuma Didas	Ward Health Officer-Manzese
14	Mr. Pontian Kitotobombo	Ward Executive Officer-Ubungo
15	Ms. Petronida Lyamuya	Ward Education Officer-Ubungo
16	Mr. Suleman Anastasi	Transport Economist-DART
17	Mr. Sabry Mabruki	Daladala Owner
18	Mr. Gwao Ujengi	Daladala Owner
19	Mr. Thaddei Mlingi	Engineer-Inter-consult
20	Mr. Balon Bodo	Bar/retail shop owner-Ubungo
21	Mr. Musa Makele	Whole sale/retail shop owner-Ubungo
22	Mr. Ameri Kisaka	Butchery owner-Ubungo
23	Mr. Ramdhani Kipanju	Retail shop owner-Ubungo
24	Mr. Mgeni Ali Rajabu	Street vendor-Seedlings-Ubungo
25	Mr. Hashim Miyanyize(physically disabled)	Street vendor-Kokoto-Ubungo
26	Mr. Charles Kimaryo	Employee-retail shop-Manzese
27	Mr. Proches Shirima	Employee-retail shop-Manzese
28	Mr. Mr. Rashid Mohamed	Street vendor-Manzese
29	Mr. Antihuman Ali	Owner of Residence-Manzese
30	Ms. Dolores Issuing	Owner of Pharmacy-Manzese
31	Mr. Genes Samba	Trader-Kagera Open Food Market
32	Mr. Hessian Mtongoja	Trader-Kagera Open Food Market
33	Mr. Ramadhani Hussen	Trader-Kagera Open Food Market
34	Mr. Emanuel Kunga	Street vendor-furniture-Kagera
35	Mr. Shukuru Ramadhani	Street vendor-furniture-Kagera
36	Mr. Rashid Johanes	Street vendor-furniture-Kagera
37	Mr. Ali Mwenquo	Street vendor-furniture-Kagera
38	Ms. Hariet M. Mkome	Residence Owner-Ndugumbi
39	Mr. Lumumba E. Mwiru	Small business owner-Mzimuni
40	Ms. Ashura A.M Massenga	Owner of residence-Mzimuni
41	Ms. Febronia A. Mshana	Owner of small business-Mzimuni
42	Mr. Philipo Lucas Odenyo	Owner of small business-Mzimuni
43	Mr. Frank Materu	Office-NGO-Magomeni
44	Mr. Hussen Yusuf	Owner of Bar-Magomeni
45	Mr. Hashim Musa Masogoa	Owner of 2 tourist hotels-Magomeni
46	Mr. Mtungi Mohamed	Carpenter-Magomeni
47	Mr. Miraji Ramadhani	Owner Small restaurant-Magomeni

Serial Number	Name	Position
48	Mr. Yassin Sambu	Owner Small restaurant-Magomeni
49	Mr. Mbaruk Hamis	Owner of Residence-Magomeni
50	Mr. Rashid Mwenda	Owner of small business-Jangwani
51	Ms. Elice Philemon M.	Owner of retail-Jangwani
52	Mr. George Chalamila	Owner of small business-saloon-Jangwani
53	Mr. Elias S. Mtikatika	Owner of small business-Jangwani
54	Mr. Said Ramadhani	Owner of small business-Upanga West
55	Mr. Abdallah Rashid	Owner of small business-Upanga West
56	Shehista Aldina	Renter of NHC-Upanga West
57	Ms. Irene Peter	Owner of small business-Upanga East
58	Mina Mpocho	Owner of medium business-Upanga East
59	Leda Marijani	Owner of medium business-Upanga East
60	Ms. Modest M. Ngonyani	Owner of medium business-Upanga East
61	Ms. Verdiana Rwegalulira	Owner of medium business-Upanga East
62	Mr. R. Lavingila	Renter of NHC-Mchafukoge
63	Mr. Y. Ratod	Renter of NHC-Mchafukoge
64	Mr. Hussein Nanji	Renter of NHC-Mchafukoge
65	Libya Filling Station (Manager)	Owner of the Libya Petrol Station-Mchafukoge
66	Mr. Ronald Komba	Street Vendor-Mchafukoge
67	Mr. Shabani Salum	Street Vendor-Mchafukoge
68	Mr. Hussen Mnunga	Street Vendor-Mchafukoge
69	Fr. Joseph Masenge	St. Joseph Cathedral-Kivukoni
70	Mr. Morician Lupolele	St. Joseph Cathedral-Kivukoni
71	Mr. Rigobert Moofe	Street Vendor-Kivukoni
72	Mr. Cyprian Juma	Street Vendor-Kivukoni
73	Mr. Nassoro Mbaga	Street Vendor-Kivukoni

DART – Dar es Salaam Rapid Transit

Environmental and Social Impact Assessment

Intersections

Comments:

Figure 1 –Morogoro Rd and Bibititi Junction

Figure 2 – Morogoro and Lumumba Junction and Morogoro and Msimbazi Junction

Figure 3 – Morogoro Rd and United Nations Junction

Data: February/2007

1/5

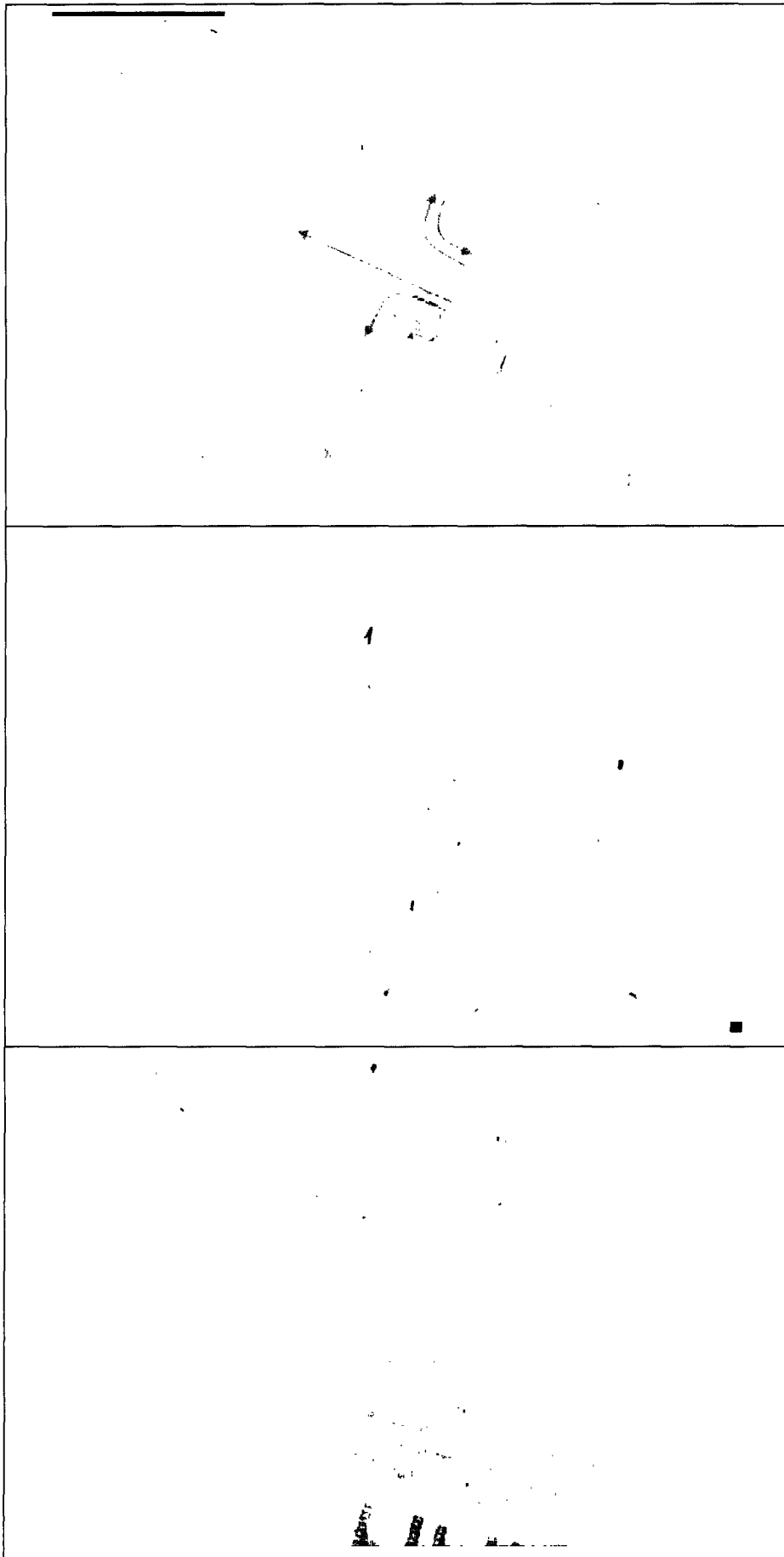

DART – Dar es Salaam Rapid Transit

Environmental and Social Impact Assessment

Intersections

Comments:

Figure 4 –Morogoro Rd and Kawawa Junction

Figure 5 – Morogoro Rd and Mabibo Junction

Figure 6 – Morogoro Rd and Shekilango Junction

Data: February/2007
2/5

DART – Dar es Salaam Rapid Transit

Environmental and Social Impact Assessment

Intersections

Comments:

Figure 7 –Morogoro Rd and Nelson Mandela/Sam Nujoma Junction

Figure 8 – Kawawa and Bagamoyo/Ali Hassam Junction

Figure 9 – Kawawa and Dunga Junction

Data: February/2007
3/5

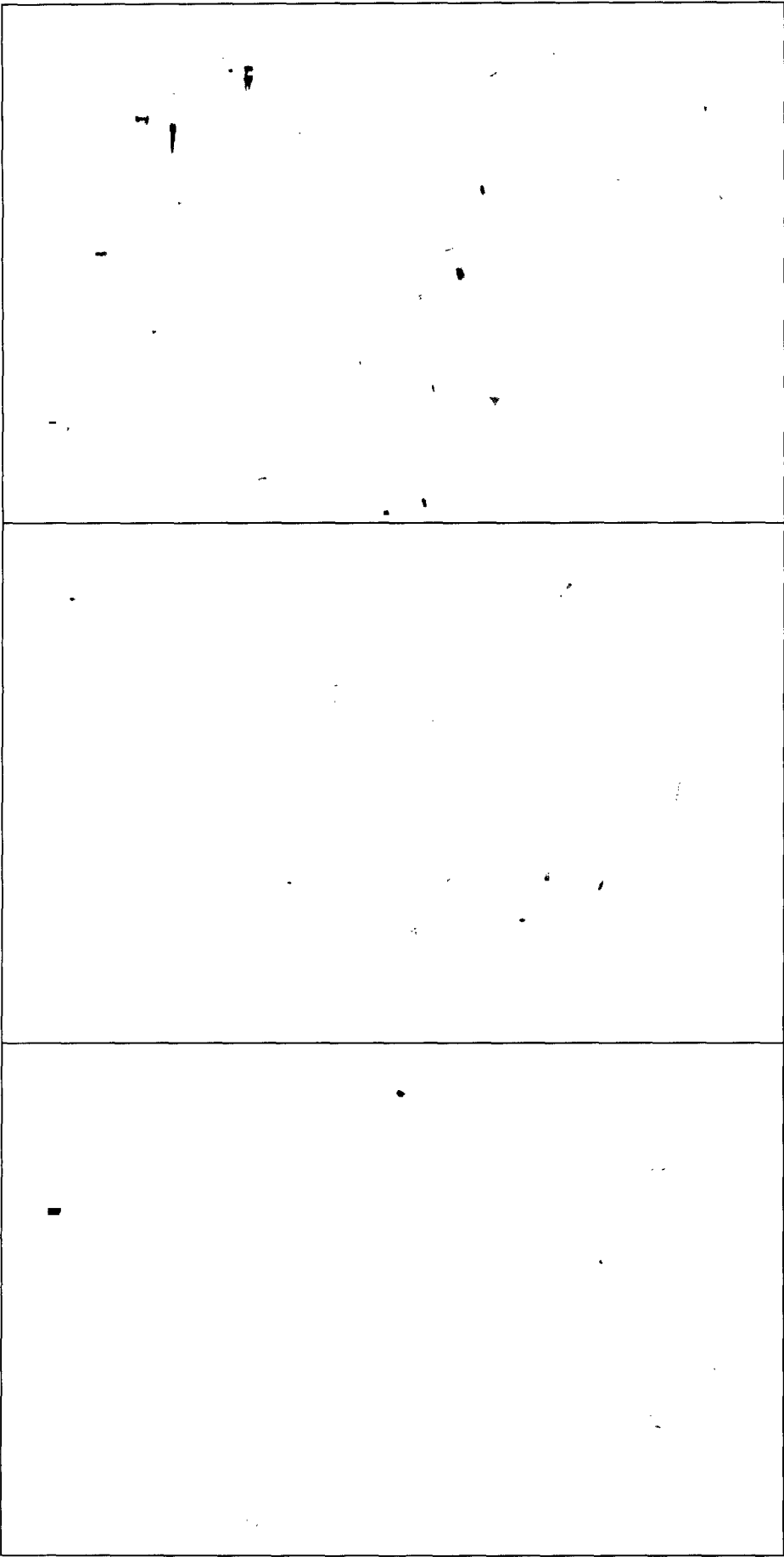

DART – Dar es Salaam Rapid Transit

Environmental and Social Impact Assessment

Intersections

Comments:

Figure 10 –Kawawa and Kinondoni Junction and Kawawa and Mwinjuma Junction

Figure 11 – Kawawa and Malongwe Junction

Figure 12 – Kawawa and Mlandizi Junction

Data: February/2007
4/5

DART – Dar es Salaam Rapid Transit

Environmental and Social Impact Assessment

Intersections

Comments:

Figure 13 – Msimbazi and Swahili Junction and Msimbazi and Mafia Junction

Figure 14 – Msimbazi and Lind Junction

Figure 15 – Msimbazi and Nyerere Junction

Data: February/2007
5/5

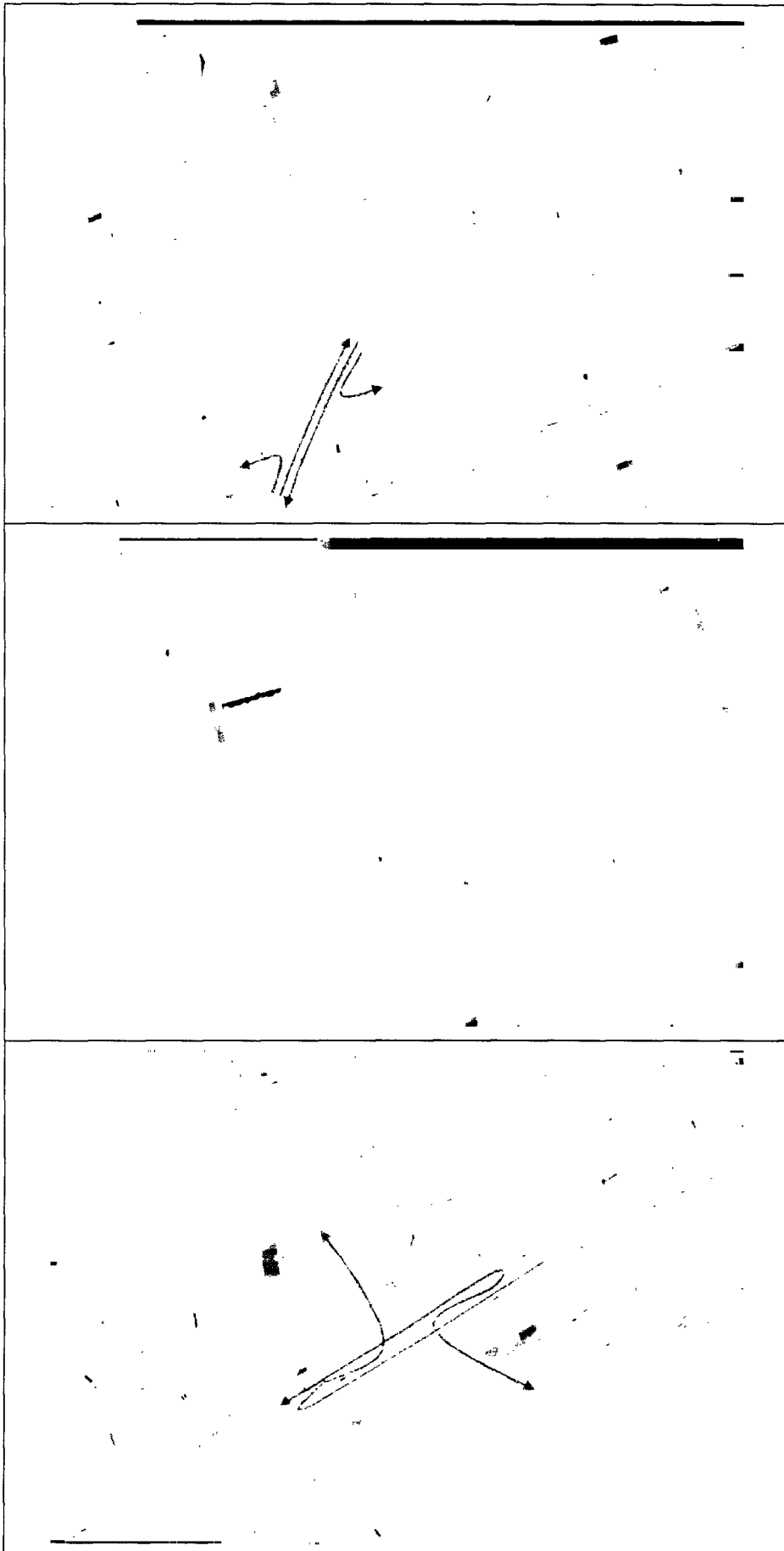



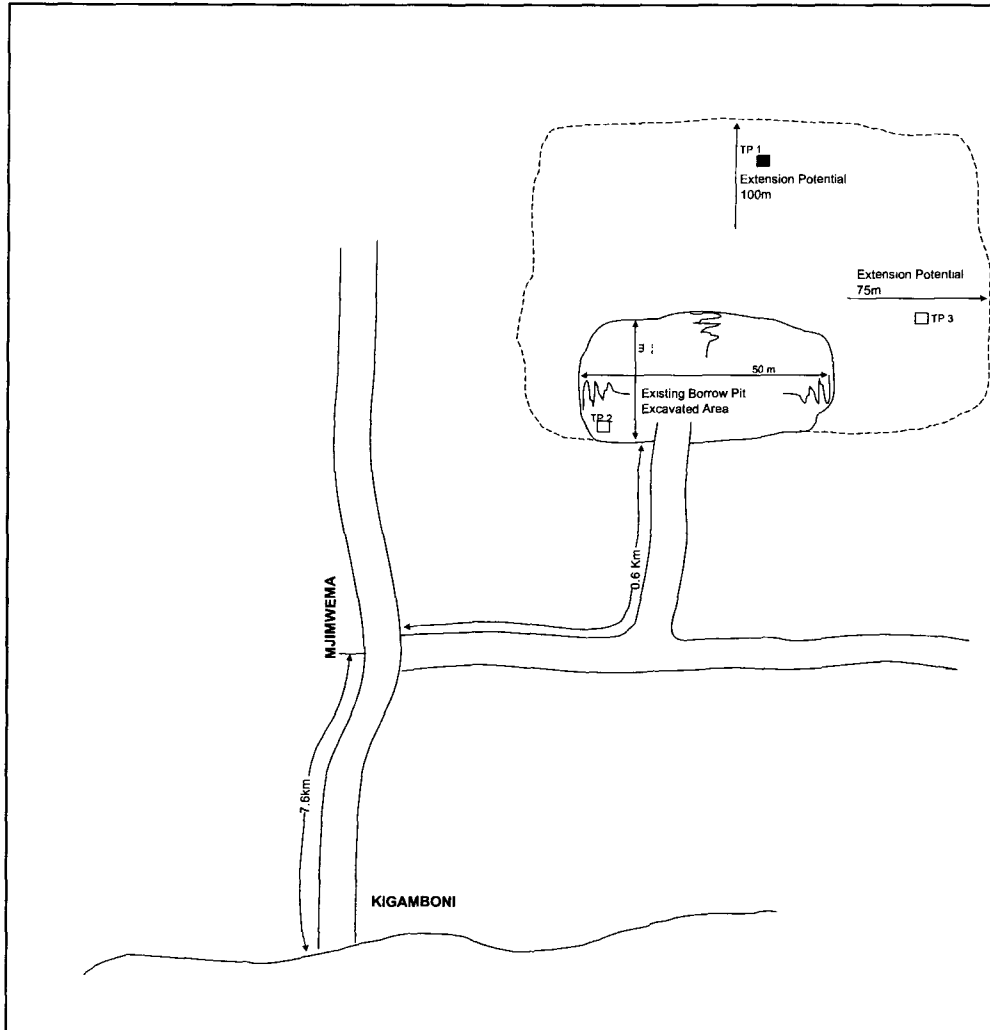

Trial Pit No.	Thickness (m)		Material Type
	Overburden	Material	
1	0,00	2.8 +	Coral limestone with clayey SAND
2	0,00	2.5 +	Coral limestone with clayey SAND
3	0,00	3.0 +	Coral limestone with clayey SAND

Material Properties	PIR Location		
	P	E	N
PI			
OMC (%)			
MDD (kg/m ³)			
CBR(%) (4-days soak)			
SWELL (%)			

LEGEND:

LG : Lateritic Gravel
 QG : Quartzitic Gravel
 GG : Granitic Gravel
 SC : Clayey Sand / Silty Clay

■ TP Sampled
 □ TP not Sampled

Overburden: NIL
 Material: Coral Limestone with lateritic red clayey SAND
 Estimated Quantity: 100 m³ per day for 6 years from January 2007
 Planned use of Material: Subbase and Base course
 Description of the place: Near to Indian ocean, many borrow pits near by, Settlement end on entry
 Distance to BP: 8.20 Km from Kigamboni

DAK ES SALAAM KAPID BUS TRANSPORT PHASE I

MJIMWEMA BORROW PIT (AMAR)

Prepared	B.M	Checked	M.D	Approved	21M
Date	Jan/07	Date	Jan/07	Date	Jan/07

LOGIT 1 JGP Sheet 1/8

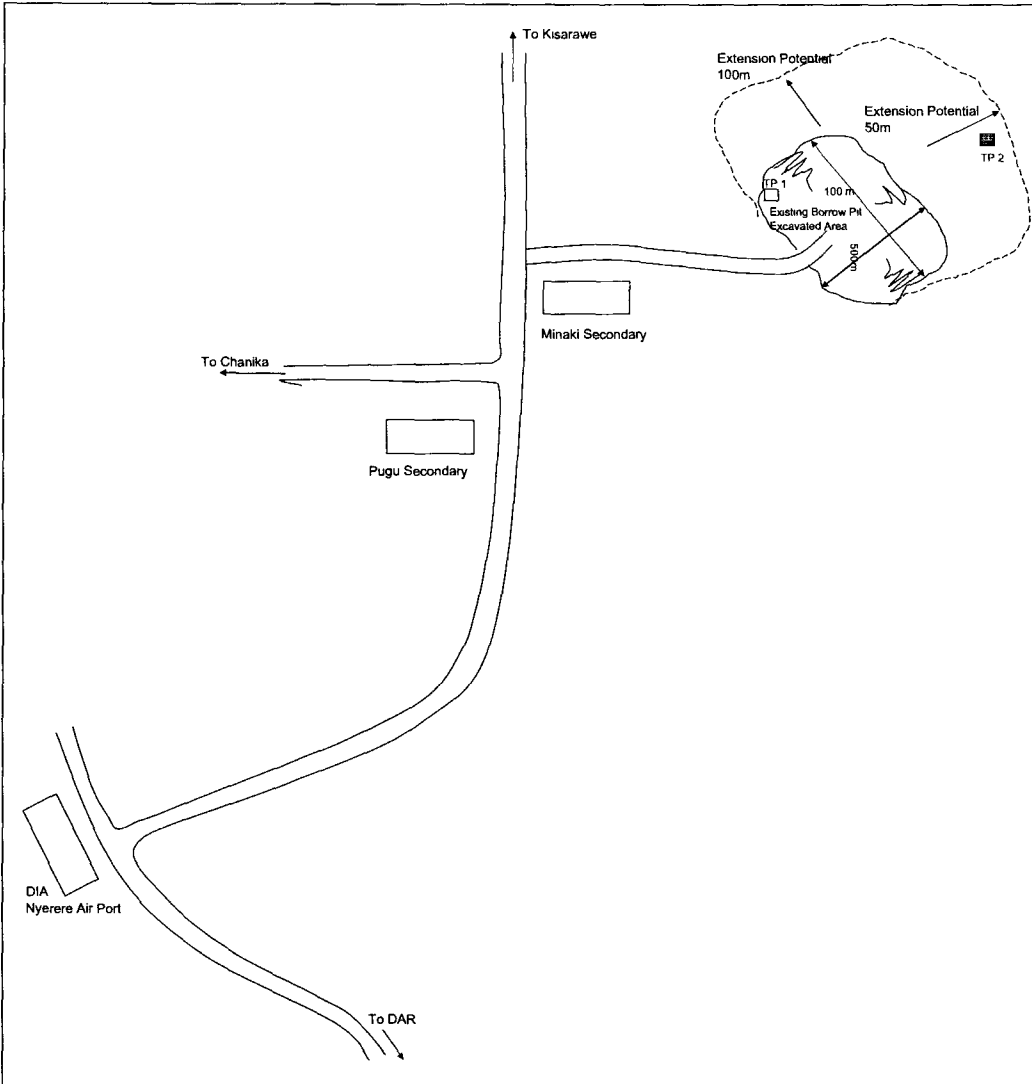

Trial Pit No.	Thickness (m)		Material Type
	Overburden	Material	
1	1,50	1,5 +	clayey sandy GRAVEL
2	1,50	2,0 +	clayey sandy GRAVEL

Material Properties	Pit Location	
	E	N
PI		
OMC (%)		
MDD (kg/m ³)		
CBR (%) (4-days soak)		
SWELL (%)		

LEGEND:
 LG : Lateritic Gravel
 QG : Quartzitic Gravel
 GG : Granitic Gravel
 SC : Clayey Sand / Silty Clay
 ■ TP Sampled
 □ TP not Sampled

Overburden Red soil, CLAY
 Material Reddish clayey sandy coral GRAVEL
 Estimated Quantity 100,000 m³
 Planned use of Material Subbase and Base course
 Description of the place: Near forest reserve.
 Distance to BP 30 950 Km from Tazara junction

DAR ES SALAAM RAPID BUS TRANSPORT PHASE I
MINAKI BORROW PIT (KISARAWA)

Prepared	B.M	Checked	MD	Approved	ZTM
Date	Jan/06	Date	Jan/06	Date	Jan/06

LOGIT | JGP Sheet 2/8

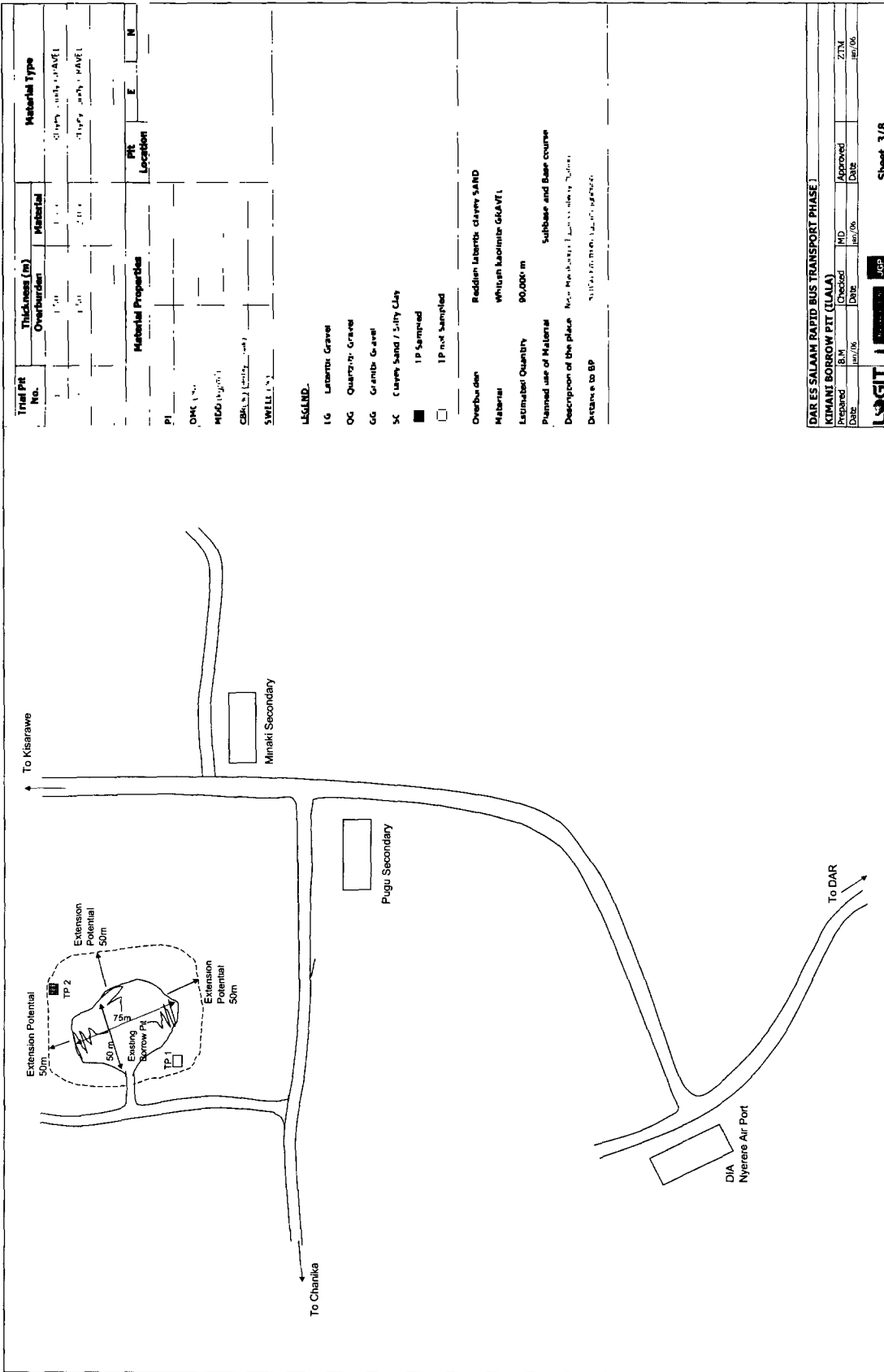

Test Pit No.	Thickness (m)	Material	Material Type
TP 1	1.00	CLAY SAND / SILTY CLAY	CLAY SAND / SILTY CLAY
TP 2	1.00	CLAY SAND / SILTY CLAY	CLAY SAND / SILTY CLAY

Material Properties	PIT Location
PI	
DMC (%)	
MO (kg/m ³)	
CBR (%)	
SWELL (%)	

LEGEND.

- 1G Laterite Gravel
- OG Quarry Gravel
- GG Granite Gravel
- SC Clayey Sand / Silty Clay

- TP Sampled
- TP not Sampled

Overburden	Reddish laterite clayey sand
Material	Whitish kaolinitic gravel
Estimated Quantity	90,000 m ³
Planned use of Material	Subbase and Base course
Description of the place	near Mwanza, Tanzania, Ministry of Works
Distance to BP	1000m from the borrow pit

DAR ES SALAAM RAPID BUS TRANSPORT PHASE I

KIMANI BORROW PIT (LALAA)

Prepared	B.M	Checked	MD	Approved	ZTM
Date	18/1/06	Date	18/1/06	Date	18/1/06

LOGIT JCP

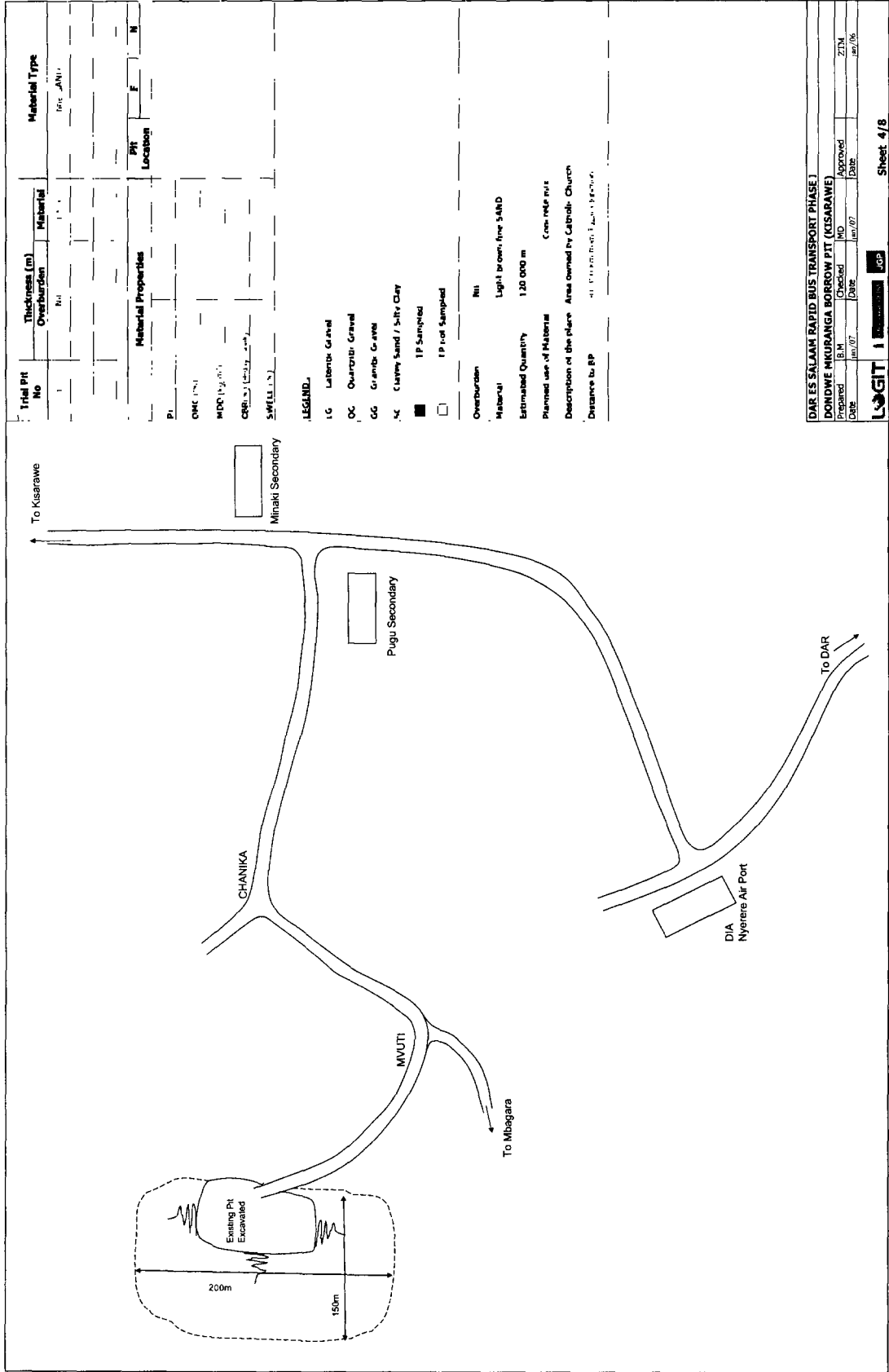

Trial Pit No	Thickness (m)	Material	Material Type

Material Properties		Pit Location	
P	N	F	N

Symbol	Material
OC	Overburden
GG	Gravel
CC	Clayey Sand / Silty Clay
IP	IP Sampled
IP	IP Not Sampled

LEGEND

- OC Overburden
- GG Gravel
- CC Clayey Sand / Silty Clay
- IP IP Sampled
- IP IP Not Sampled

Overburden Pit
 Material Light brown fine SAND
 Estimated Quantity 120 000 m³
 Planned use of Material Concrete mix
 Description of the Place Area owned by Catholic Church
 Distance to BP 41.1 km (road) 1.2 km (straight)

DAR ES SALAAM RAPID BUS TRANSPORT PHASE I
 DONDWE MKURANGA BORROW PIT (KISARAWE)

Prepared	Checked	Approved
BY: [Signature]	DATE: [Date]	DATE: [Date]

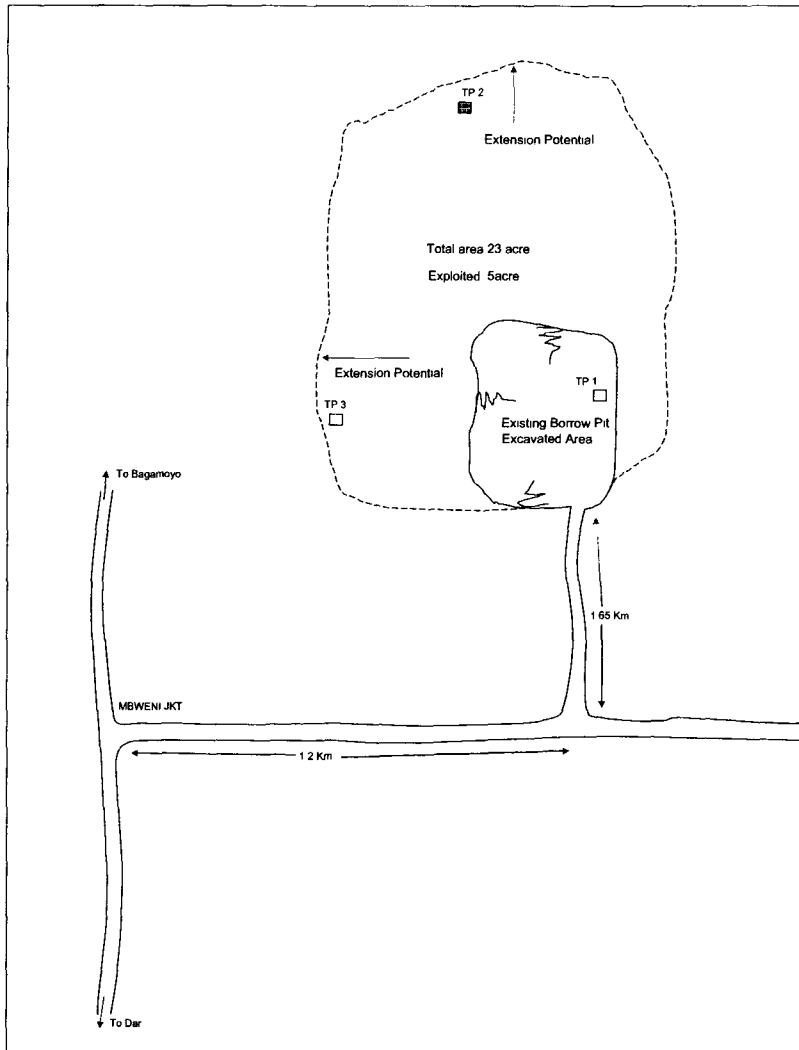

Trial PH No.	Thickness (m)		Material Type
	Overburden	Material	
1	0,30	1.5 +	clayey sandy coral GRAVEL
2	0,30	2.5 +	clayey sandy coral GRAVEL
3	0,30	2.0+	clayey sandy coral GRAVEL

Material Properties	PH Location		
	P	E	N
PI			
OMC (%)			
MDD (kg/m ³)			
CBR (%) (4-days soak)			
SWELL (%)			

LEGEND:
 LG : Lateritic Gravel
 QG : Quartzitic Gravel
 GG : Granitic Gravel
 SC : Clayey Sand / Silty Clay
 ■ TP Sampled
 □ TP not Sampled

Overburden Reddish clay
 Material Light brown lateritic clayey sandy coral GRAVEL
 Estimated Quantity 350,000m³
 Planned use of Material Base course and sub base
 Description of the place: Area owned by Kara Arjan and Sons Ltd
 Distance to BP 22.10 Km from Mwenje Junction

DAR ES SALAAM RAPID BUS TRANSPORT PHASE I
 Burju Moyofoka/Mbweni JKT

Prepared	B.M	Checked	MD	Approved	ZTM
Date	25/07	Date	25/07	Date	25/07

LOGIT i JGP Sheet 5/8

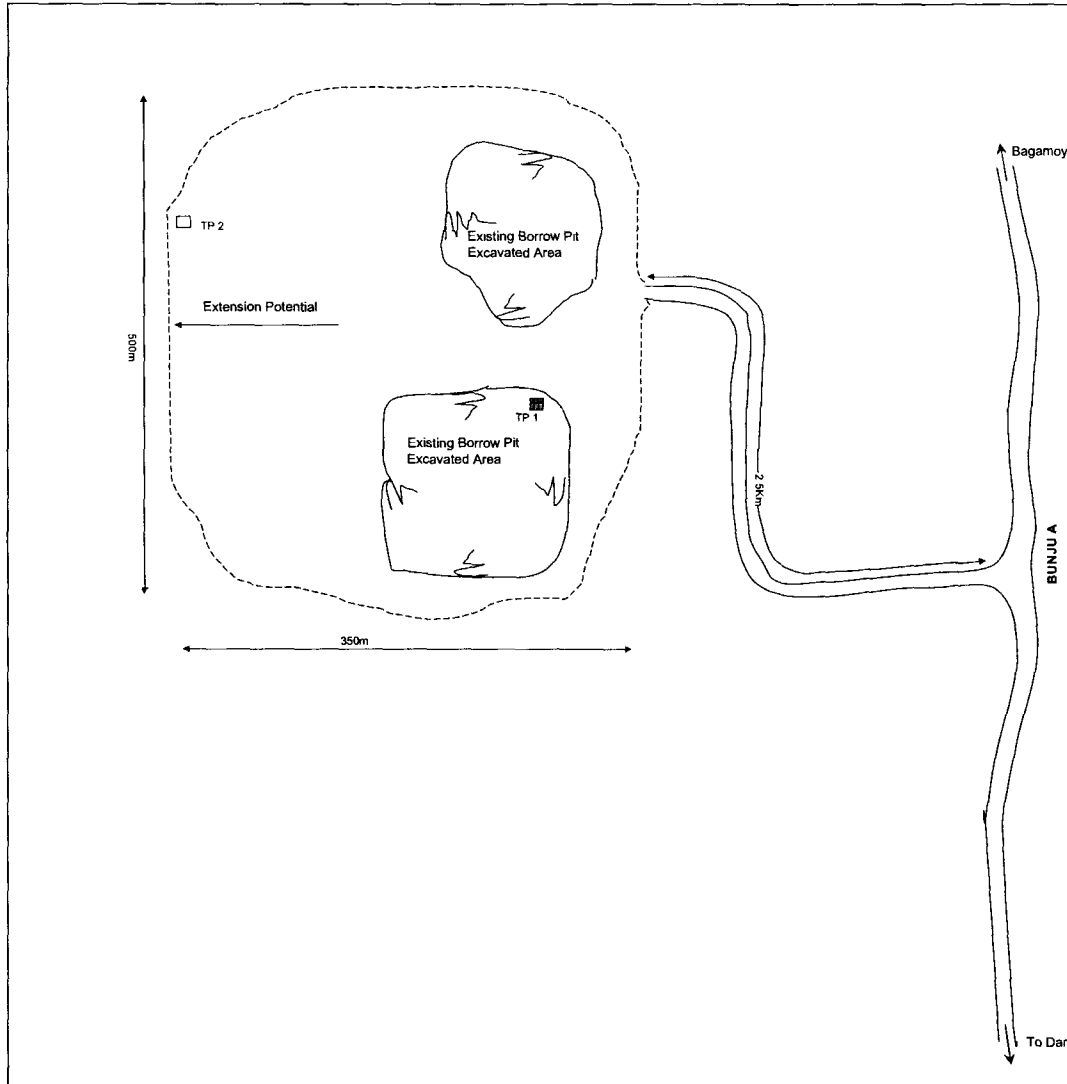

Trial Pit No	Thickness (m)		Material Type
	Overburden	Material	
1	1,00	2.8 +	Lateritic clayey coral GRAVEL
2	1,00	2.5 +	Lateritic clayey coral GRAVEL
3	1,00	2.0 +	Lateritic clayey coral GRAVEL

Material Properties	Pit Location		
	E	N	
PI			
OMC (%)			
MDD (kg/m ³)			
CBR (%) (4-days soak)			
SWELL (%)			

LEGEND:

- LG : Lateritic Gravel
- QG : Quartzitic Gravel
- GG : Granitic Gravel
- SC : Clayey Sand / Silty Clay
- TP Sampled
- TP not Sampled

Overburden: Greyish brown clay
 Material: Light brown lateritic clay coral GRAVEL
 Estimated Quantity: 200,000m³
 Planned use of Material: Base course and sub base
 Description of the place: Area owned by Noremco, Kimambi, etc
 Distance to BP: 25.35 Km from Mwenge junction

DAR ES SALAAM RAPID BUS TRANSPORT PHASE I

Bunju A					
Prepared	B.M	Checked	MD	Approved	ZTM
Date	jan/07	Date	jan/07	Date	jan/07

LOGIT i JGP Sheet 6/8

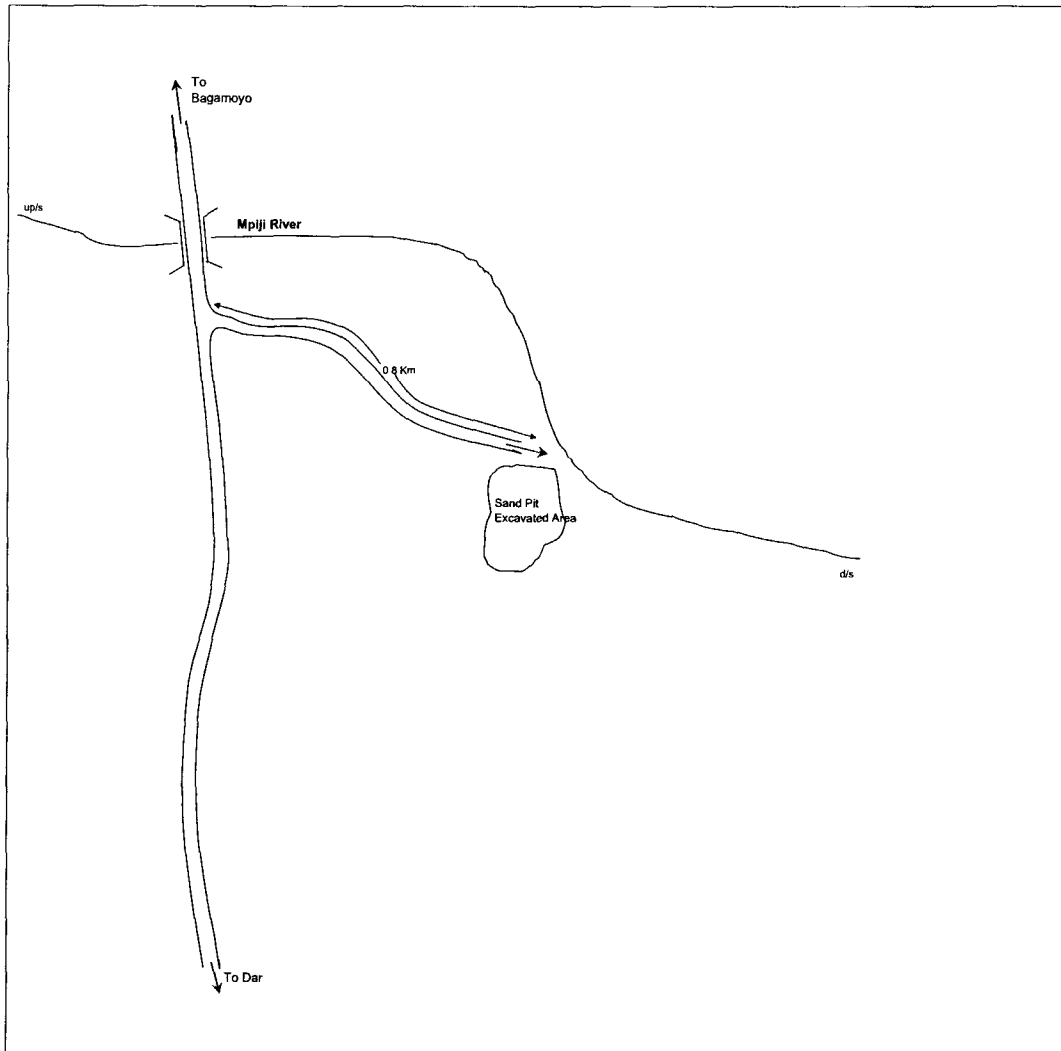

Trial Pit No.	Thickness (m)		Material Type
	Overburden	Material	
1	0,00	1.8 +	medium SAND

Material Properties	PIH Location	
	E	N
PI		
OMC (%)		
MDD (kg/m ³)		
CBR (%) (4-days soak)		
SWELL (%)		

LEGEND:

- LG : Lateritic Gravel
- QG : Quarzitic Gravel
- GG : Granitic Gravel
- SC : Clayey Sand / Silty Clay
- TP Sampled
- TP not Sampled

Overburden: Nil
 Material: Light brown medium SAND
 Estimated Quantity: 100,000m³
 Planned use of Material: Concrete work
 Description of the place: There are two sources, River source and Pit source, No building near by area.
 Distance to BP: 27.15 Km from Mwenje junction

DAR ES SALAAM RAPID BUS TRANSPORT PHASE 1
Mpji River Source

Prepared	B.M	Checked	MD	Approved	ZTM
Date	Jan, 07	Date	Jan, 07	Date	Jan, 07

LOGIT JGP Sheet 7/8

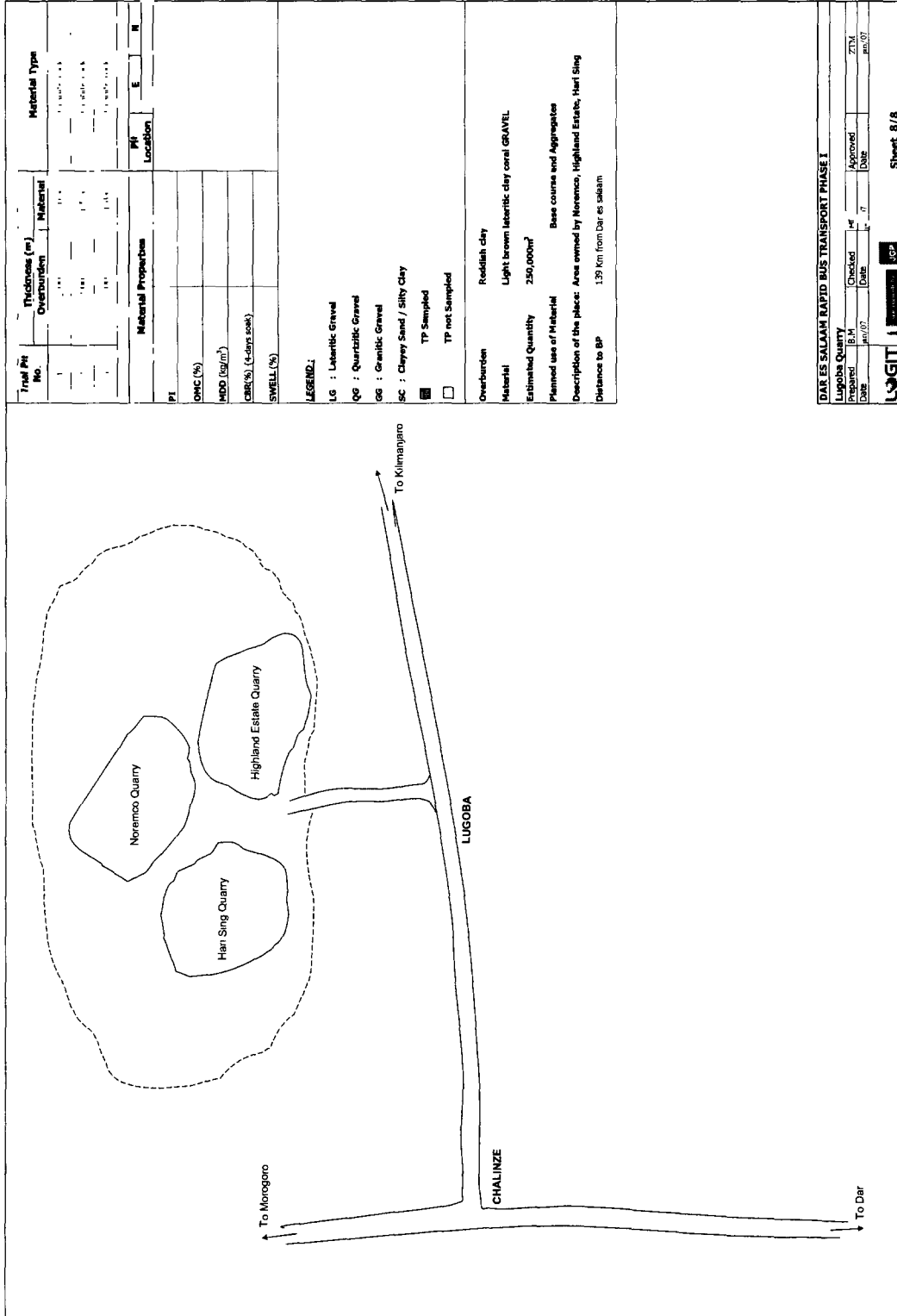

Trail Pit No.	Thickness (m) Overburden	Material	Material Type
1	1.00	LG	Subarctic Gravel
2	1.00	QG	Quartzitic Gravel
3	1.00	GG	Granitic Gravel
4	1.00	SC	Clayey Sand / Silty clay

Material Properties		Pit Location	
PI	Location	E	N
1			
2			
3			
4			

LEGEND:
 LG : Lobaritic Gravel
 QG : Quartzitic Gravel
 GG : Granitic Gravel
 SC : Clayey Sand / Silty clay

TP Sampled
 TP not Sampled

Overburden: Reddish clay
Material: Light brown lateritic clay coral GRAVEL
Estimated Quantity: 250,000m³
Planned use of Material: Base course and Aggregates
Description of the place: Area owned by Noremoo, Highland Estate, Hai Sing
Distance to BP: 139 Km from Dar es Salaam

DAR ES SALAAM RAPID BUS TRANSPORT PHASE I

Lugoba Quarry
 Proposed Date: 18/11/07
 Checked Date: 18/11/07
 Approved Date: 27/11/07

LOGIT | **UGP** | **UGP** | **UGP**

Sheet 8/8

DART – Dar es Salaam Rapid Transit

Environmental and Social Impact Assessment

Articulated Bus and Feeder Bus Illustrations

Comments:

Figure 1 – Articulated Bus (trunk system)

Figure 2 – Articulated Bus Layout

Figure 3 – Microbus (feeder system)

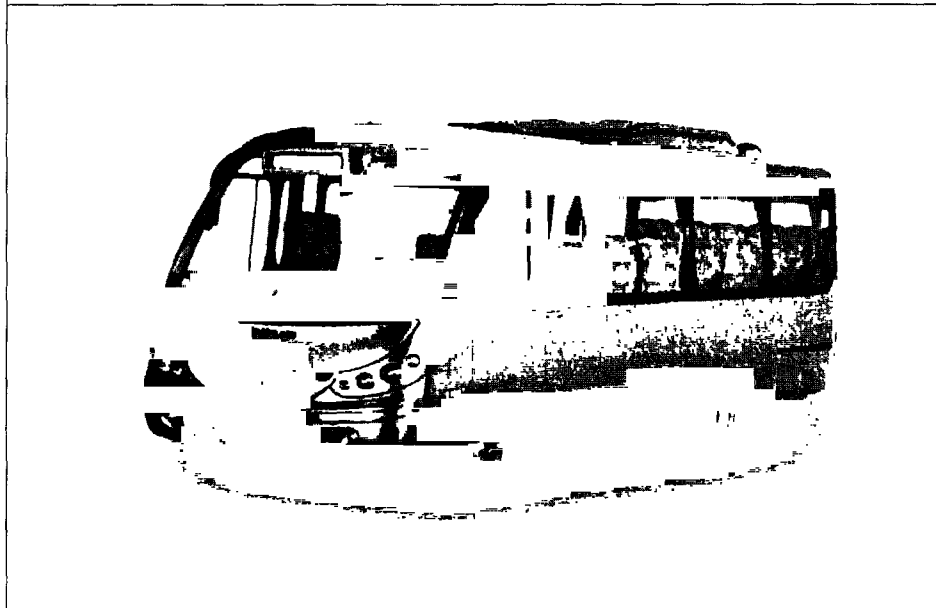
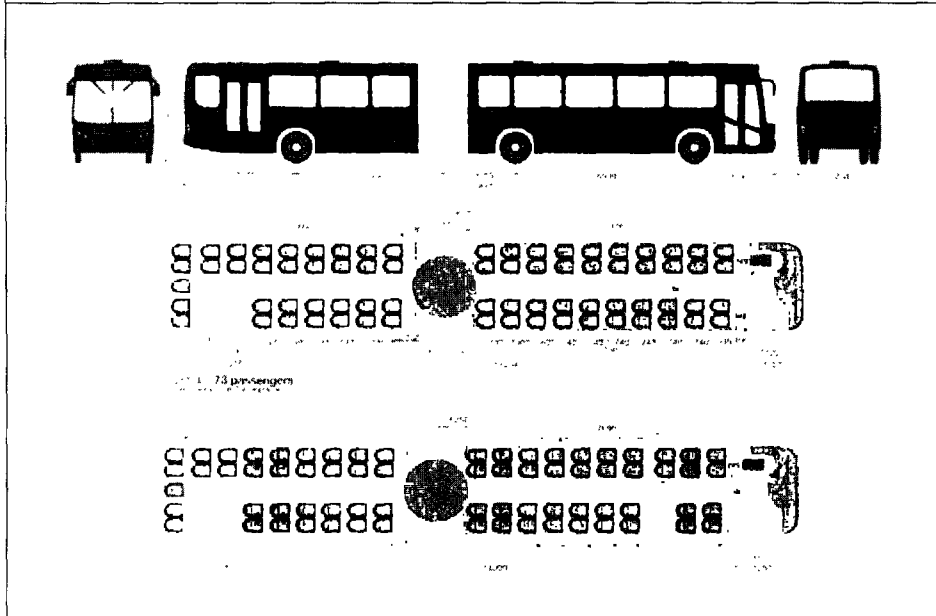
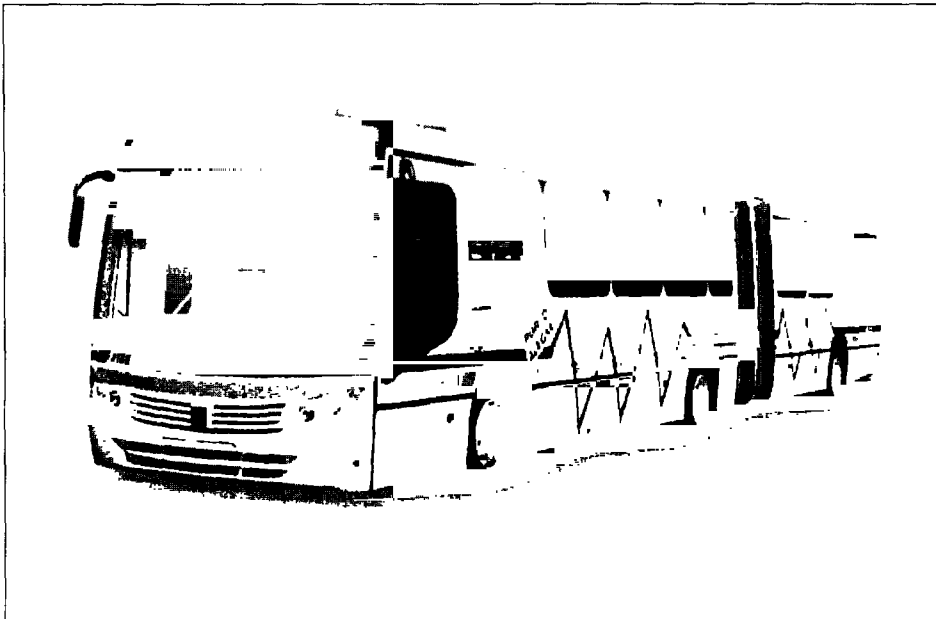

Date: February/2007
1/2

DART – Dar es Salaam Rapid Transit

Environmental and Social Impact Assessment

Intersections

Comments:

Figure 5 – Microbus Layout

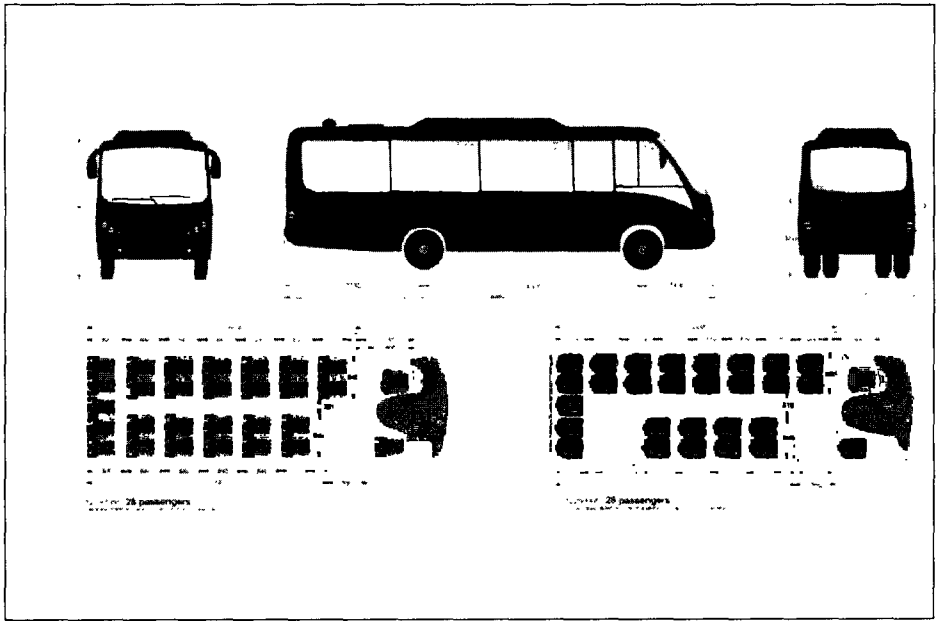

Date: February/2007
2/2

Integrated Dar Es Salaam BRT System Phase I

Annex 5 – Current and Proposed Routes for IAI Daladala Services to be Re-routed

I N D E X

1.0 Daladala Routes to be Removed

- 1.1 Morogoro Road Routes Analysis
- 1.2 Kawawa Road Routes Analysis
- 1.3 Inventory of Routes to be Removed

2.0 Daladala Routes to be Rerouted

- 2.1 CBD Flow and Kivukoni Terminal Access
- 2.2 Muhimbili Hospital Access
- 2.3 Kariakoo Market, Msimbazi Street and Mnazi Mmoja terminal access

According to the explained measures and conditions to be executed along with the implementation of DART BRT system in the city of DSM, the reorganization of existing public transportation is, after the implementation of the new system itself and all its agents and institutional structure, the second most important task to execute by the city and its officials.

The reorganization of existing daladala routes was formulated mainly by considering two main aspects: offering a rational public transport offer along DART's first phase corridors Morogoro and Kawawa Roads giving preference to the new and sustainable BRT system and to initiate the process of renovating the concept of public transportation of passengers in the city. Alongside with these elements, this reorganization will definitely help reducing transport externalities of congestion, pollution (atmospheric and noise) by cutting general transportation over plus.

Within the city and up to the last measurement of daladala routes done in May 2005, there were 196 daladala routes in operation along a network of approximately 322 kilometers out of about 1,200 kilometers of available roads (both paved and unpaved) in the entire DSM area. For first phase implementation, the current daladala routes operating along Morogoro Road and part along Kawawa Road should be removed from operation. A total of 43 daladala routes will be removed from operation and the service will be taken by DART system, leaving a remaining of 148 operational routes running along 296 kilometers on the rest of the city.

Some other destinations will be also touched by the system's coverage area, thus having more affected public routes, for which the measure was an obliged redesign or rerouting.

An existing daladala routes reassignment was proposed according to the rerouting layout suggested during the design period and also widely consulted within local and regional authorities. Having cleared that DART operation should not have as a threat the existing rivalry between daladalas, the rerouting allows a smooth operation and that poses no conflict in the daily movements between this two.

1.0

Daladala Routes to be Removed

As explained before, the deletion of routes was done on those routes which by coverage and extension, are within the DART influence area and give service between the same origin – destination pairs. The analysis was focused on those ones running along the main corridors included in the first phase design, Morogoro and Kawawa Roads.

The entire process of DART system feeder services design considered the existing coverage offered by the daladala routes operating, thus the elimination of any route within the city comes with the subsequent solution offered either by a feeder route or DART trunk service.

1.1 Morogoro Road Routes Analysis

Given the fact that DSM has a very scarce road network, particularly on main arteries, Morogoro Road gives access and exit from and to the city towards the western part and regional roadway to Morogoro and inside Tanzania, with no other viable alternative as auxiliary road, meaning that the existing transport demand have no other alternative and will be captive demand of any new transportation system developed along this road.

At Jangwani area, along Morogoro Road (between United nations Road and Kawawa Road) there were calculated a total of 39 routes out of which the 75% (29 routes) are coming from western areas along Morogoro Road and the remaining 25% (10 routes) comes from northern parts along Kawawa Road. (**Figure 1.1.a**).

The remaining 4 routes correspond to those coming from western areas but exit Morogoro Road towards destinations such as Sinza, Msasani and Mwenge. These routes after running along Morogoro Road take either Sam Nujoma or Shekilango roads but should be included into the reorganization scheme as well.

Analyzed and evaluated the implementation scenario, all the existing routes, the mentioned ones and any other in operation after the survey was done, which operate along Morogoro Road should be removed to ensure the demand analysis for DART to be accomplished.

The following map shows the removed routes from Morogoro road.

Figure 1.1.a
Morogoro Road Removed Routes

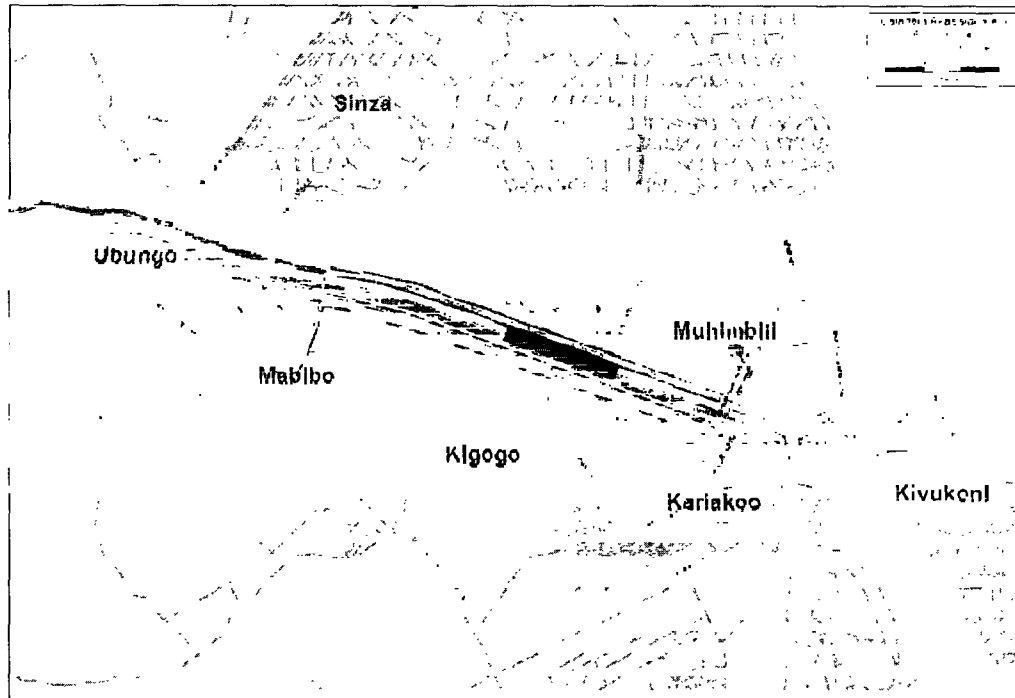

1.2 Kawawa Road Routes Analysis

Kawawa Road as an example of mixed operation between BRT services and existing daladala routes, was a result of analyzing a joint situation for which the demand technical requirements obliged the extension towards the north combined with the city's existing and scarce road layout, offered little solution for a potential daladala rerouting if it was realized that Kawawa Road works as a double ensemble connector for city's trip desires originated and with destination on the north areas with pairs either on the south and CBD areas.

Those relevant to the CBD and Kariakoo areas were captive trips to be served by DART system but those on route to the south (Temeke, Tandika, Mbagala, and destinations along Nyerere Road, among others) had to be preserved to ensure a reasonable and rightful service. The proposed deletion comes to those routes turning east on Morogoro Road and with destinations on the CBD area and Kariakoo.

It is important to keep in mind the fact that along the 3.5 kilometers of DART Kawawa corridor, the existing public transportation (daladalas) and the proposed DART system will be sharing the flow and eventually the demand with origins and destinations in common

along the stretch mentioned. However, the system and enforcement agencies should encourage the users to use the appropriate service, either DART or daladala upon their travel desires, if going to southern destinations to ride daladala and otherwise to use DART. As aforementioned, the existing scheme of 30 daladala routes coming southbound from Kawawa Road, a 33% (10 routes) turn east on Morogoro, being this 33% the ones to be removed from operation, leaving the remaining 67% of routes (20 routes) how they are.

Special treatment should be addressed to the physical design to be prepared along this stretch (Morocco Terminal to Morogoro Road intersection) given the fact that there should be a functional effective relation between the standard DART stations and daladala bus stops or stands, ensuring a harmonized operation as well as pleasant and comfortable from the urban design point of view.

Figure 1.2.a
Kawawa Road Removed and Preserved Routes

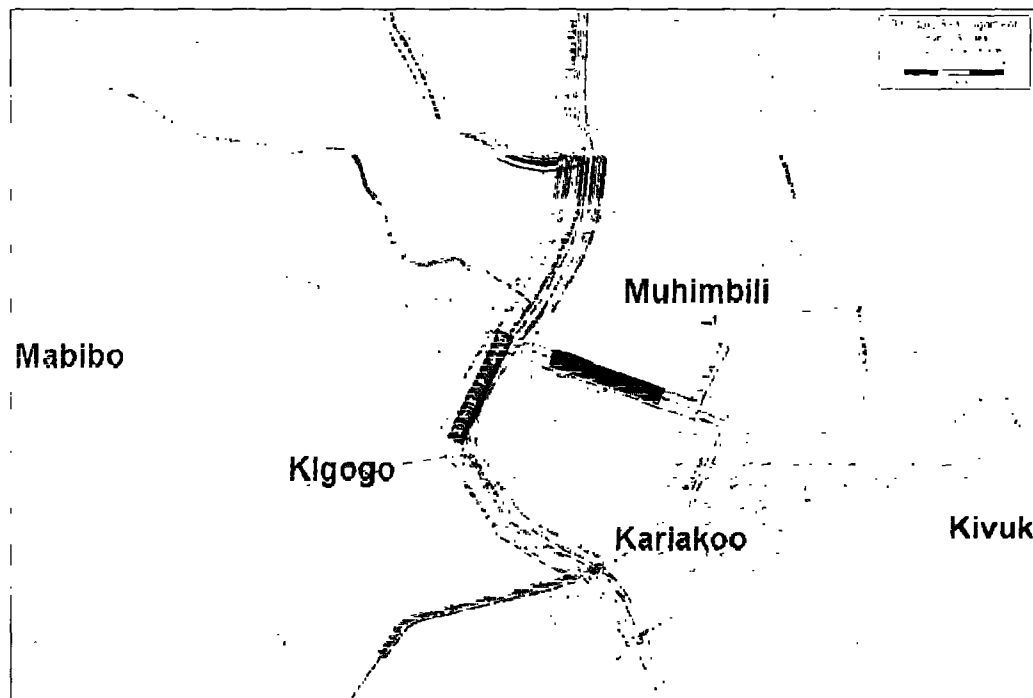

1.3 Inventory of Routes to be Removed

After the analysis done, the list of routes to be removed obtained is as showed in **Table 1.3.a**. A total of 43 daladala routes were selected for deletion.

Table 1.3.a
Daladala Routes to be Removed

KARIAKOO-BUNJU	
KARIAKOO-KAWE	MWENGE-KARIAKOO
KIBAMBA-KARIAKOO	MWENGE-KARIAKOO
KIBAMBA-MUHIMBILI	MWENGE-POSTA
KILUVYA-KARIAKOO	UBUNGO-MWENGE
KIMARA-KARIAKOO	SINZA-KARIAKOO
KIMARA-KIVUKONI	SINZA-POSTA
KIMARA-MUHIMBILI	KARIAKOO-TEGETA
KIMARA-POSTA	UBUNGO-KARIAKOO
MABIBO-KARIAKOO	UBUNGO-KIVUKONI
MABIBO-KIVUKONI	UBUNGO-MUHIMBILI
MABIBO-MUHIMBILI	UBUNGO-MWANANYAMALA
MABIBO-POSTA	UBUNGO-POSTA
MANZESE-KARIAKOO	KIBAMBA-KIVUKONI
MANZESE-POSTA	KIBAMBA-MANZESE
MBEZI-KARIAKOO	KIBAMBA-MWENGE
MBEZI-KIVUKONI	KIBAMBA-POSTA
MBEZI-MUHIMBILI	KIMARA-MSASANI
MBEZI-POSTA	MANZESE-MUHIMBILI
UBUNGO-MSASANI	KARIAKOO-MSASANI
MWANANYAMALA-KARIAKOO	SINZA-MUHIMBILI
MWANANYAMALA-KIVUKONI	VINGUNGUTI-SINZA

Figure 1.3.a
Reorganization Layout –Current and Future Transportation Coverage

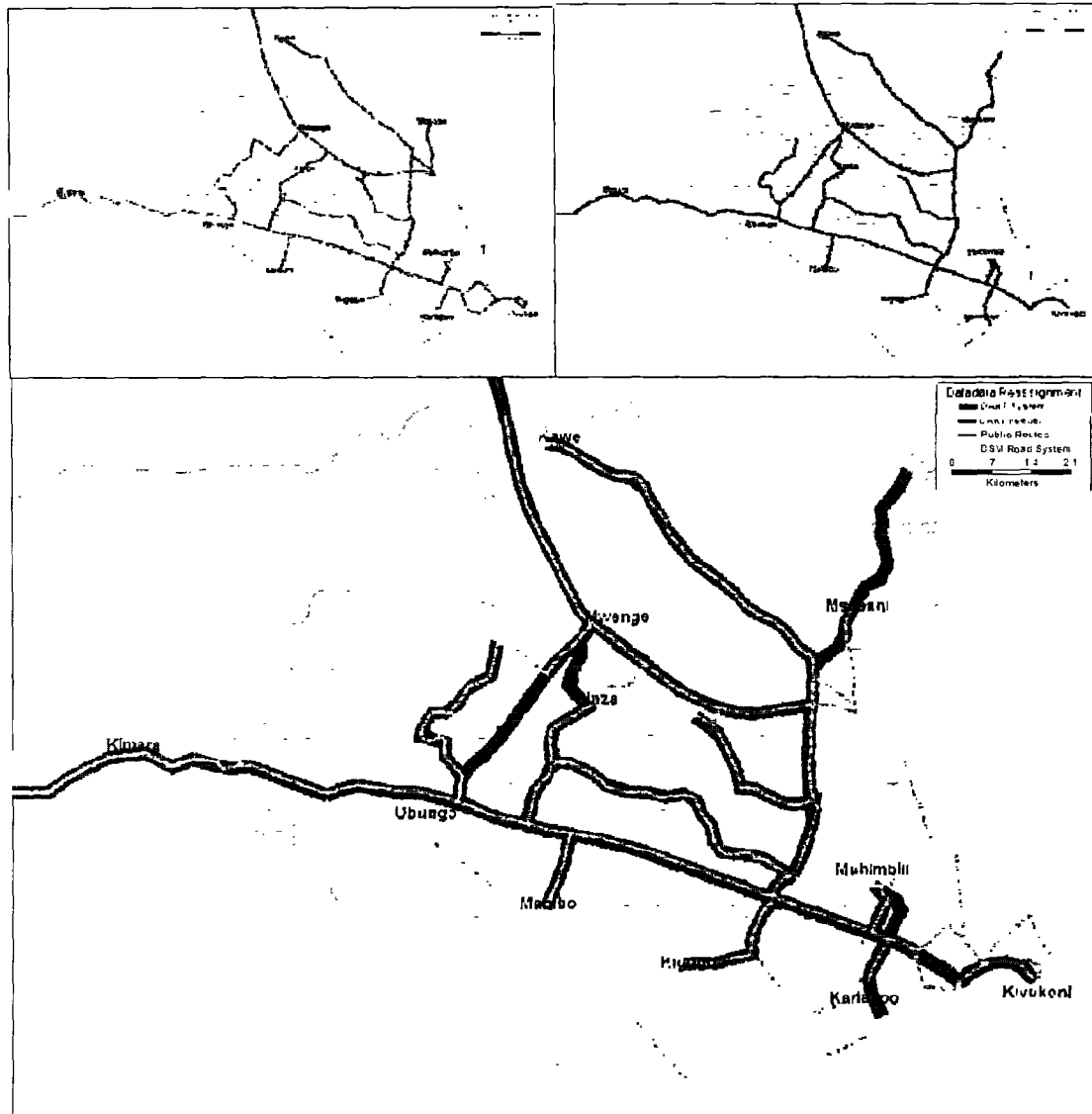

Figure 1.3.a structures graphically the transportation coverage before and after DART implementation. The final overlap explains how the system, though removing routes is actually improving the network’s coverage and extension.

2.0

Daladala Routes to be Rerouted

As explained before, Morogoro Road represents the principal access to DSM city center – Kivukoni and Posta, Muhimbili Hospital and Kariakoo Market area. Existing routes running on Morogoro Road with these destinations are included in the “to be removed routes list” thus leaving for discussion what to do with the remaining routes that have to continue offering service to these crucial points.

Consequently, the rerouting process was addressed on finding feasible and operationally efficient alternatives to preserve the current accessibility, promoting urban renovation and improvement, enhancing CBD and surrounding areas traffic flow and allowing DART implementation to be as smooth and hassle-free as possible.

The rerouting process was developed on analyzing with three different areas:

- General CBD daladala flow and Kivukoni Terminal access.
- Muhimbili Hospital access.
- Kariakoo Market, Msimbazi Street daladala flow and Mnazi Mmoja terminal access.

Relevant to the decisions taken for rerouting and by balancing the proposal with the general CBD streets directions redefinition, the alternatives here showed are applicable as they are if and only if this redefinition and the support infrastructure changes (new intersections and traffic signaling technology improvement) are executed and implemented before to the public transportation changes take place.

A complete display of the pre and post stages for all the modified routes is found as an annex of the present Volume.

2.1

CBD Flow and Kivukoni Terminal Access

One major challenge throughout the conceptual proposal and further design of the BRT system, was the definition of a new traffic flow concept for CBD streets, particularly along those ones where DART was decided to operate on, altogether with the desired characteristics and the requirements of rearranging the existing traffic conditions and daladala routes to match the service standards expected of this urban renovation project. The consultants as results of previous experience on similar areas have recommended as much as possible to use on CBD , one way streets basically for two reasons:

- 1- capacity: on intersections, one way street reduces conflicts: for example on simple crossing on two double way street there are 16 possible movements

- and dozens of conflicts between these movements, while on two crossing one way streets there are just one conflict. On signalized intersections usually capacity may increase more than 100%
- 2- safety: on one way streets pedestrians need to look just to one side, and on a crossing a maximum of two flows must be observed. In Dar CBD, where there are a lot of narrow roads one very close to the other, seems a wonderful place to use one way street as a general rule.

The streets of Sokoine Drive and Kivukoni Front were the ones that required special attention since these were directly affected by the new traffic scheme and introduction of the mass transit system. Subsequently, and considering the “loop” like current operation of traffic and, particularly that of public transportation accessing and leaving the CBD area, other affected streets were Uhuru Street, Bibi Titi Road, and Maktaba/Azikiwe Street. Nevertheless the new arrangements and urban improvement introduced to the CBD area, the existing public transportation for which any willing daladala route could access either Kivukoni Terminal or Posta by following the aforesaid loop, the new scheme will not allow the same heavy traffic and daladala passenger flow along the existing path approaching this area.

The design considers the development of an improved waterfront, integrating non motorized transportation, mass transit and mixed traffic but not allowing daladala routes to flow along the same path, mainly because space constraints. Mixed and BRT traffic will share the right of way on the ferry-bound direction and no mixed traffic flow will be allowed on the southern direction along this waterfront promenade. Explaining this idea, **Figure 2.1.a** shows extent of the proposed waterfront treatment.

Designs along with this report are considering a more conservative cross section reducing the development on the sea side for cost purposes but the recommendation bears in mind the future development of the whole urban renewal proposal.

The analysis considered and followed:

- Complete evaluation of future traffic movements along with the interaction with DART.
- Introduction of one way streets within the entire CBD area for major and transit streets.

Figure 2.1.a
Complete Proposal for Waterfront Road Cross Section

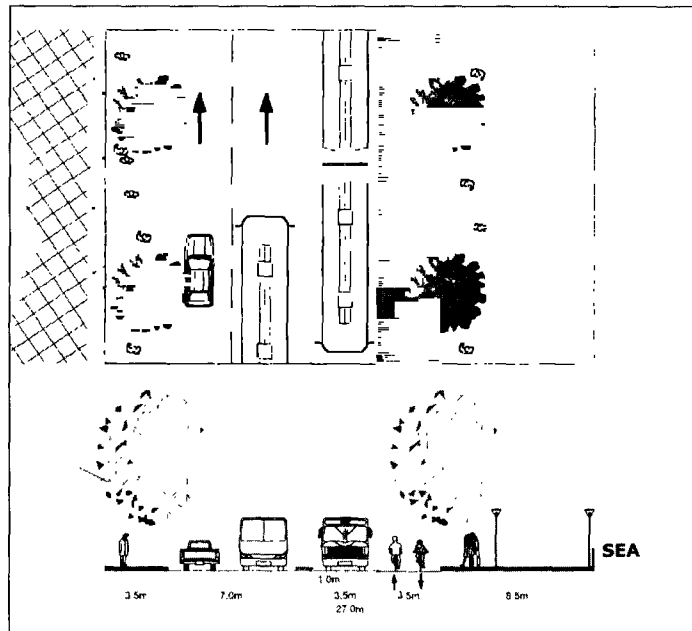

- Available movements and new arrangements and flow definitions for Bibi Titi Road intersections (See annex volume 8 Chapter 8.1 – Traffic Management Impact and Mitigation) given the fact that this road demarcates the CBD limits.
- Kivukoni Front and Sokoine Drive being one way streets mandatory from Morogoro Road to Ferry terminal.
- Suggestions and recommendations received from city and municipal authorities regarding the use and convenience for using or not certain streets.

After making a revision of the available roads that could eventually give access to remaining daladala routes with itineraries ending in Kivukoni in combination with the street direction change, a proposal was obtained giving a functional operation for every movement within the CBD.

This proposal comprises four elements to be executed in a joint action plan for CBD traffic management and flow improvement. It is recommended to implement these measures in the following order always along enforcement and education.

- Construction of new and adaptation of existing intersections along Bibi Titi Road (see document VII.A. Traffic Management Impact and Mitigation).

- Street directions change. To be executed with an initial pedestrianization of Morogoro Road, preparing the area for future construction and DART operation.
- DART Infrastructure construction along waterfront.
- Once DART starts being operational, the daladala reorganization should be implemented, both route deletion and rerouting process.

Figure 2.1.b
CBD Street Direction Proposal

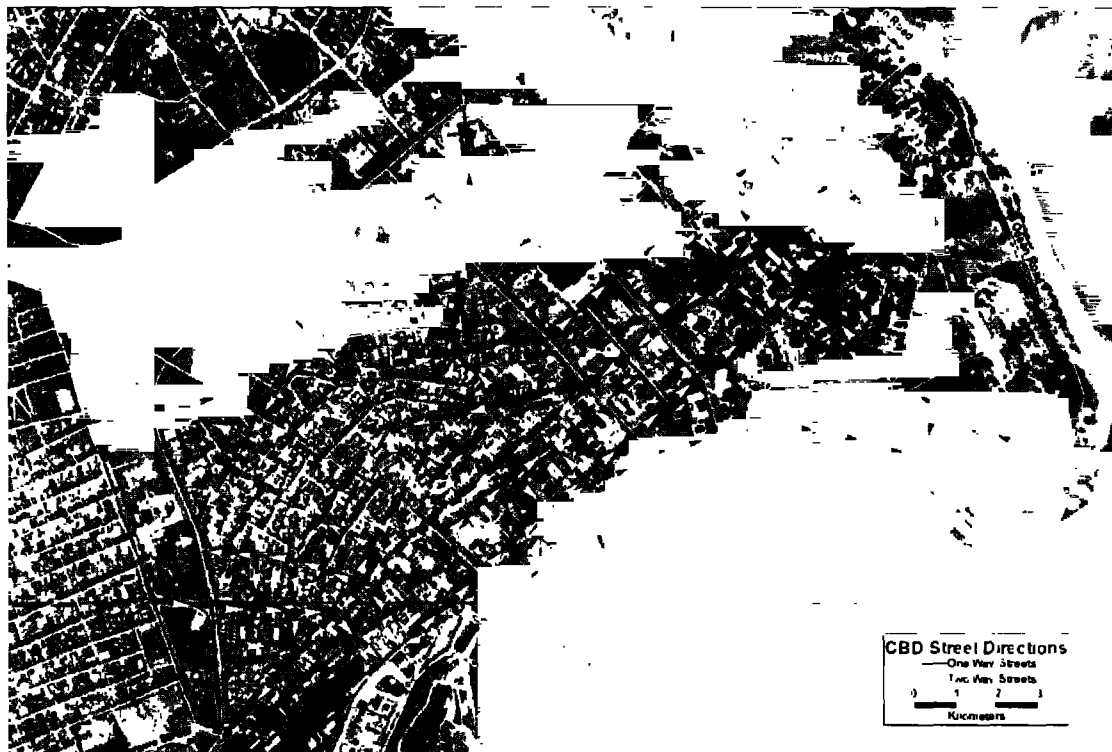

The existing direction pattern for CBD’s roads considers is almost entirely dominated by two way flow streets with little one way examples. A new layout of the proposed rearrangement is shown in **Figure 2.1.b**. Main highlights in the proposed changes are the reverse in direction of Sokoine Drive and Samora Avenue, Zanaki Street being a one way street towards the waterfront.

Following on the proposal steps, for the CBD, the daladala rerouting considers the detour of buses running from Azikiwe Street onwards to Kivukoni to alternate circulation on roads other than Kivukoni Front, Sokoine Drive and Uhuru Street on the way out of the CBD. Presently the path followed by daladalas is the following (**Figure 2.1.c** and **Figure 2.1.d**):

EXISTING INBOUND CBD ROUTE

All daladalas access the CBD area from Bibi Titi Road, entering through Maktaba/Azikiwe Street down to Kivukoni Front and, depending on the final destination, proceed to Kivukoni Terminal or outbound CBD taking Sokoine Drive to the southwest destinations.

Figure 2.1.c
CBD Existing Inbound and Outbound Daladala Flow

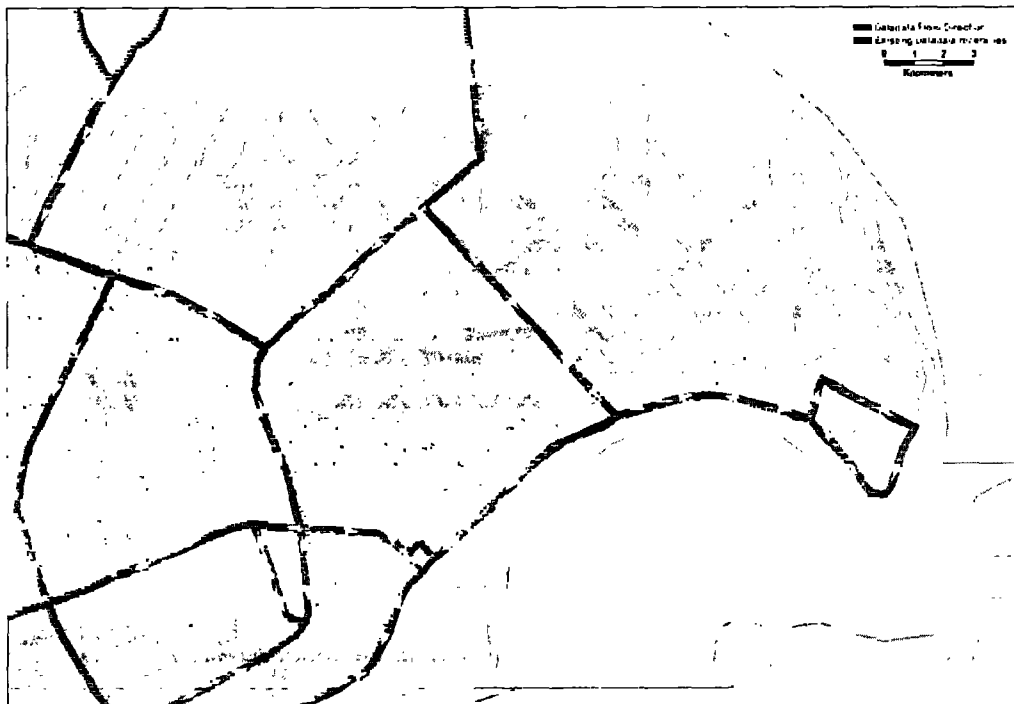

EXISTING OUTBOUND CBD ROUTE

The exit is done based on the daladala destination outside the city. The ones with destinations on the north take back Maktaba/Azikiwe Street up to Bibi Titi Road, and the ones going west and south continue along Sokoine Drive, later taking Uhuru Street or continuing on Sokoine towards Bandari Road to south destinations (Mtoni, Mbagala, and others).

Based on this perspective and with the intention of finding roadways in good conditions, the alternative found operationally feasible considers the following corridors, both inbound and outbound CBD area:

PROPOSED INBOUND CBD ROUTE

Having the usual itinerary as the existing one, the daladalas will continue accessing the CBD area through Azikiwe/Maktaba Street. At the intersection with the later and Garden Avenue the daladalas with destination to Kivukoni Terminal will detour and continue heading northeast to Ocean Road, on which they will proceed towards Kivukoni Terminal. Routes with Posta as a final itinerary will continue their existing flow but instead reaching Kivukoni Front, they will detour northeast on Sokoine Drive and then left on Pemba Road, point where was assumed the end of the CBD-bound route.

For the routes accessing from the south which currently run on Uhuru Street both inbound and outbound CBD, considering the changing in Uhuru Street direction and the introduction of Aggrey Street as the pair street, the circulation will obey the new direction pattern with Aggrey Street connecting Sokoine Drive with Bibi Titi Road and Uhuru Street doing the same link in the opposite direction. The entrance to Stesheni Terminal will follow the same street direction patterns abovementioned.

PROPOSED OUTBOUND CBD ROUTE

The major difference on the rerouting proposal is the management of outbound routes, considering the fact that the entire existing operating pattern changes. For routes coming from Kivukoni the exit corridor will comprise again the use of Ocean Road in the reverse way until Samora Avenue junction and then along this one up to the roundabout with Azikiwe/Maktaba Street intersection, proceeding along this one towards Bibi Titi Road, corridor which will be the exit channel for the entire daladala fleet serving the CBD.

Once on Bibi Titi Road, the routes will continue either to Uhuru Street or Nyerere Road on their way out of the CBD. A special treatment is being proposed for Uhuru Street and the flow of vehicles coming out of the CBD. With the idea of not allowing intersections of more than 2 phases in the operation, the requirement of a right turn on Uhuru Street intersection for routes entering Kariakoo region from Bibi Titi Road will be served by a new intersection to be opened on Mkunguni Street adjacent to Morogoro Road junction. Following to this right turn the exiting daladala traffic will continue on Lumumba until reaching Uhuru Street where they will take their usual itinerary.

Figure 2.1.d
CBD Proposed Inbound and Outbound Daladala Flow

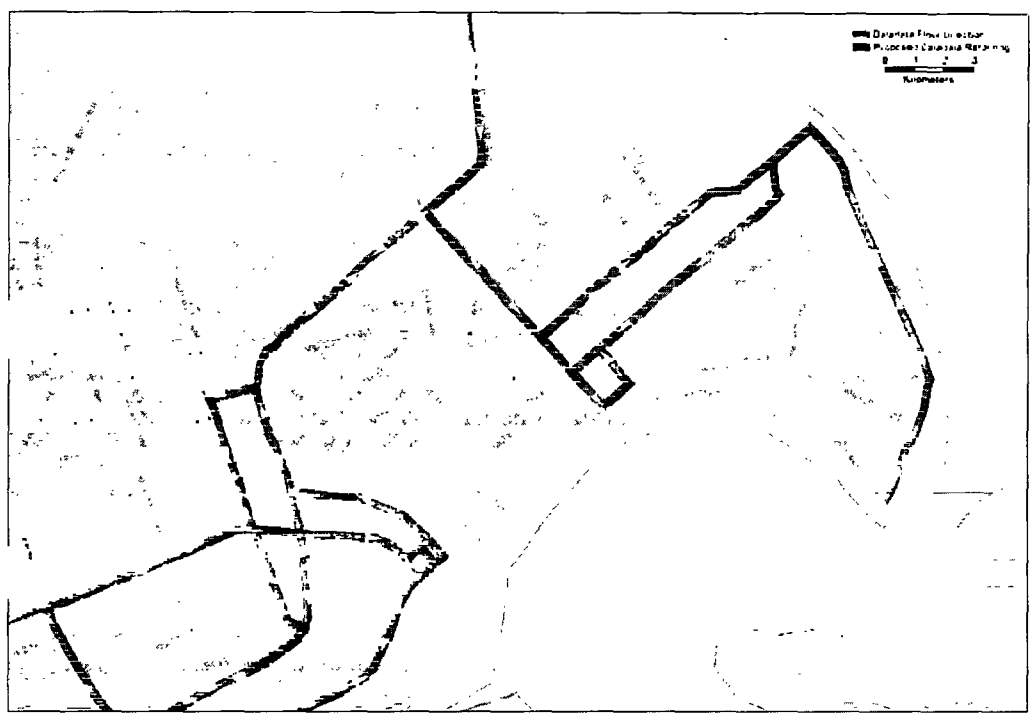

For the routes leaving from Posta and continuing with the explanation started on the Inbound CBD section, after running on Pemba Road they will use Samora Avenue to access to Maktaba/Azikiwe Street and proceed with the outbound path explained for Kivukoni routes.

2.2
Muhimbili Hospital Access

Along with the conception of the CBD rerouting proposal, the alternative for accessing Muhimbili Hospital required the identification of auxiliary roads on which the remaining routes with Muhimbili Hospital as a final destination could run and continue offering coverage to this important region.

Within the feeder services conceived for DART’s first phase, it was included the design of a major transfer station and feeder route to Muhimbili given the observed high passenger demands. In addition, the corridor will access Kariakoo area by entering through Msimbazi Street, street currently used by daladalas coming from southern origins to access and leave Muhimbili Hospital from and to Uhuru Street, Nyerere Road or Kilwa Road. Since the daladala flow will also be banned for circulation along Msimbazi Street, the alternative

route implied the complete displacement of this group of daladalas from the Msimbazi Street flow and the utilization of a new entrance for Muhimbili Hospital, additional to the one given by United Nations Road.

By analyzing and recognizing the area of Upanga, its accessibility, surrounding roads and streets, infrastructure quality and condition, land use, among others the results for defining a new route didn't give much options leaving one main solution with feasible conditions and minor impacts. Briefing the existing and proposed situations, **Figure 2.2.a** and **Figure 2.2.b** illustrate graphically the change.

EXISTING INBOUND MUHIMBILI ROUTE

The existing path taken by daladalas going to Muhimbili Hospital and coming either from Uhuru Street or Nyerere Road consists of entering Kariakoo market area through Msimbazi Street, north on this until Morogoro Road, continuing on this west one block until the junction with United Nations Road, through which the daladalas get access to the Upanga region and the hospital.

Figure 2.2.a
Muhimbili Hospital Existing Daladala Access

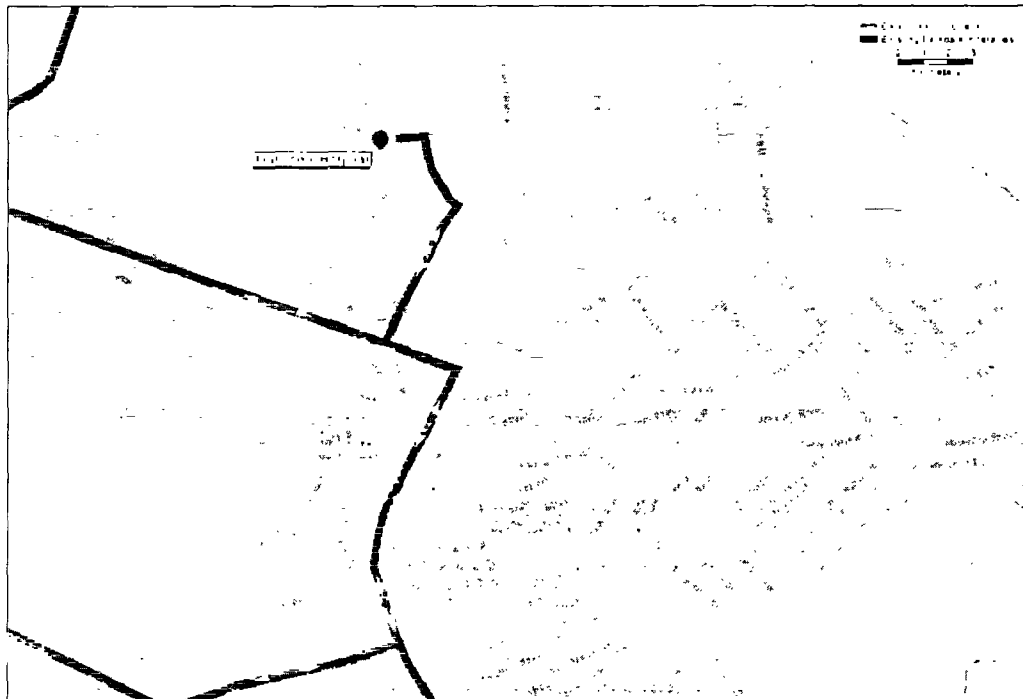

PROPOSED OUTBOUND MUHIMBILI ROUTE

Having Bibi Titi Road as a primary support, the connection for remaining routes accessing Muhimbili Hospital would now commence from either Uhuru Street or Nyerere Road and instead taking Msimbazi Street, the new path will use Bibi Titi Road up until the junction with Olympio Street on the Upanga Mashariki ward.

The path continues along Olympio Street one block northwest, then northeast on Allykhan Street until Magore Street. This road will conduct daladalas straight to Maliki Road through which the Hospital has its daladala terminal. Important infrastructure improvements have taken place on the Upanga region roads (paving of Magore Steet among others), facilitating the introduction of this new public transportation routes arrangements.

Figure 2.2.b
Muhimbili Hospital Proposed Daladala Access

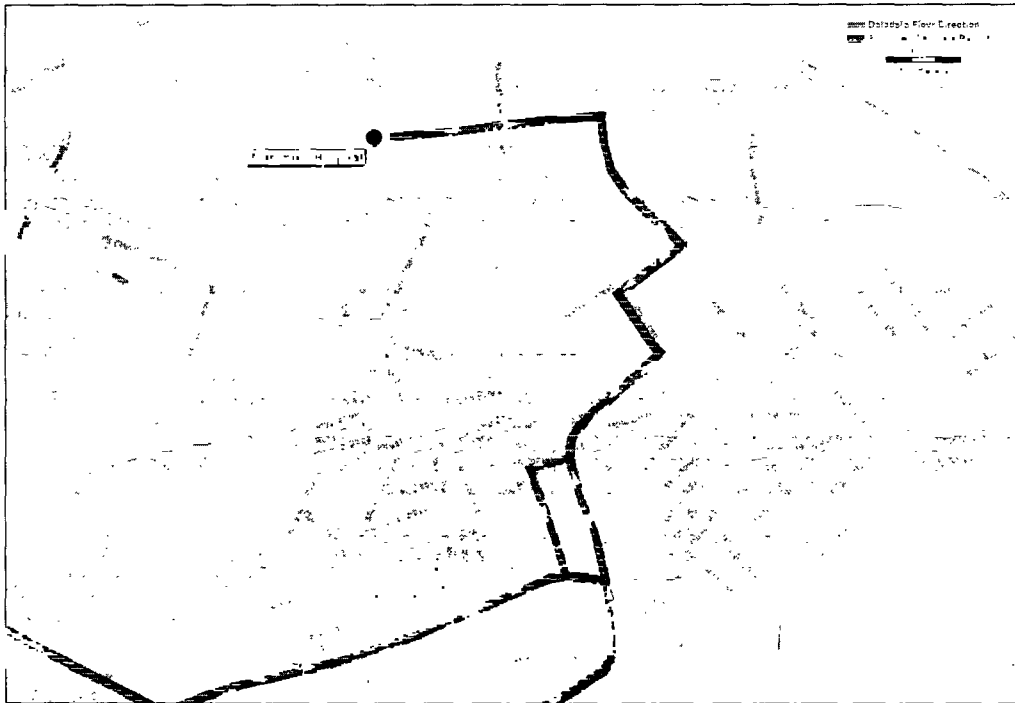

2.3

Kariakoo Market, Msimbazi Street and Mnazi Mmoja terminal access

Complimentary to DART implementation along with the early stages of direction flow changes for CBD streets, the Kariakoo market area requires attention as well; it will evolve from being probably the busiest street in the whole Dar es Salaam to an almost BRT dedicated street. The traffic flow treatment then has to be treated in a way that the future flows will not affect DART or themselves.

The existing flows on the Mnazi Mmoja region and south part of Msimbazi Street are shown in Figure 2.3.a.

Figure 2.3.a

Mnazi Mmoja and South Msimbazi Street Existing Daladala Flow

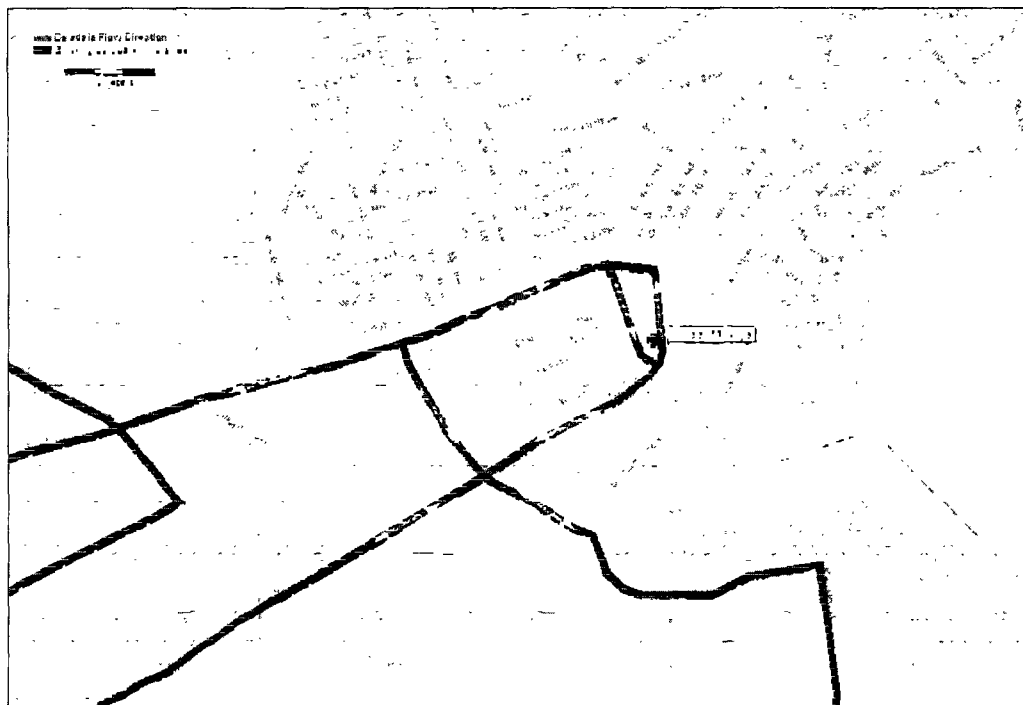

What is important to notice about the area along Msimbazi Street is that since the main reorganization is removing the most important share of the existing heavy traffic, primarily daladalas entering from Morogoro Road, the remaining traffic and daladala routes will continue running along the southern stretch (between Uhuru Street and Nyerere Road). The impact would be focused on the infrastructure point of view, considering that the design should accommodate at least a mixed traffic lane southbound to keep the connection for the

routes that are currently coming inbound and there are no conventional stations on this stretch, other than the proposed Kariakoo DART Terminal.

The flows on this area will continue as they are but special attention should be addressed on enforcement on this street to assure the free flow and traffic harmony specially in front the DART terminal to avoid confusions and disorganizations potentially encouraged by remaining daladala operation.

Figure 2.3.b
Mnazi Mmoja and South Msimbazi Street Proposed Daladala Flow

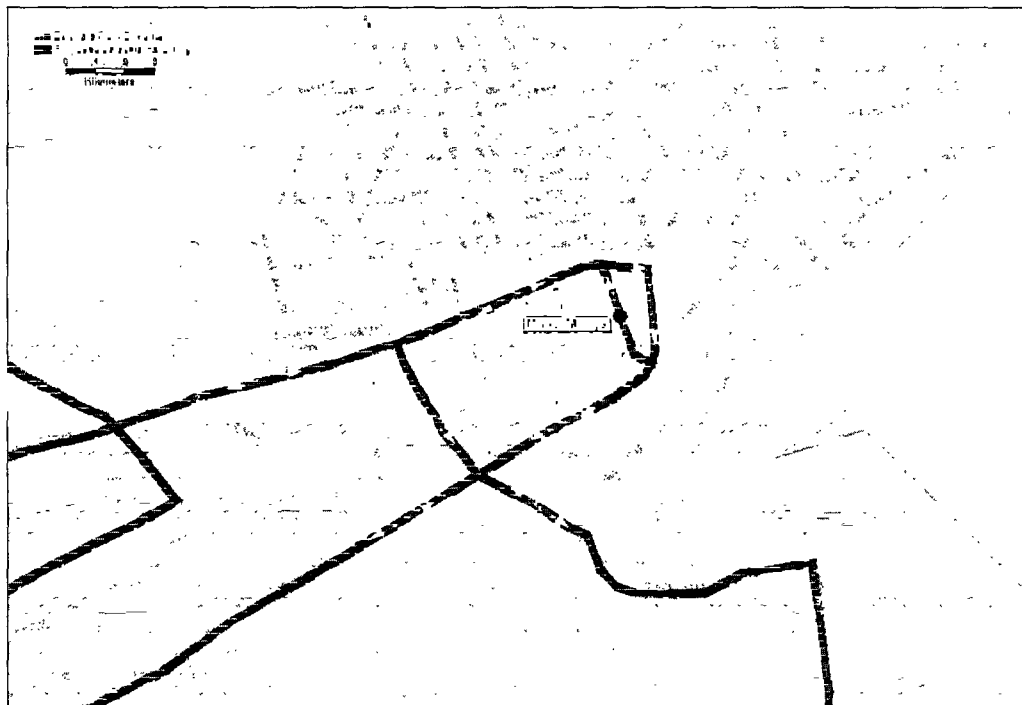

A change, though being minor in appearance, represents a major outcome for the entire zone flow and future synchronization with the new CBD street flow proposal. As seen from comparing **Figure 2.3.a** and **Figure 2.3.b**, the flow on the ring/triangle Lumumba/Uhuru Streets and Bibi Titi Road will change from a counterclockwise (flow begins on Lumumba Street, Bibi Titi Road and finally Uhuru Street) to a clockwise operation (Uhuru, Bibi Titi and Lumumba) for Mnazi Mmoja daladalas. Even though the terminal is located at present on the northbound side of Bibi Titi Road, the proposal suggests its relocation along Lumumba Street.

**DART – Dar es Salaam Rapid
Transit**

**Environmental and Social
Impact Assessment**

**VEGETATION
PHOTOGRAPHIC
REPORT**

Comments:

Figure 1- Mangrove at Salender Bridge near the mouth of Indian Ocean

Figure 2 - Typical Tree grove vegetation at Old Post Office

Figure 3 - Typical Street strip vegetation along Sokoine Drive

Date: February, 2007

1/4

**VEGETATION
PHOTOGRAPHIC
REPORT**

Comments:

Figure 4- Typical Shade tree/lawn
at Kinondoni along Kawawa road

Figure 5 - Typical Lawn
Vegetation between Ubungo and
Kimara along Morogoro road

Figure 6 - Vegetation cover at
Proposed Feeder Exchange station
at Kimara

Date: February, 2007
2/4

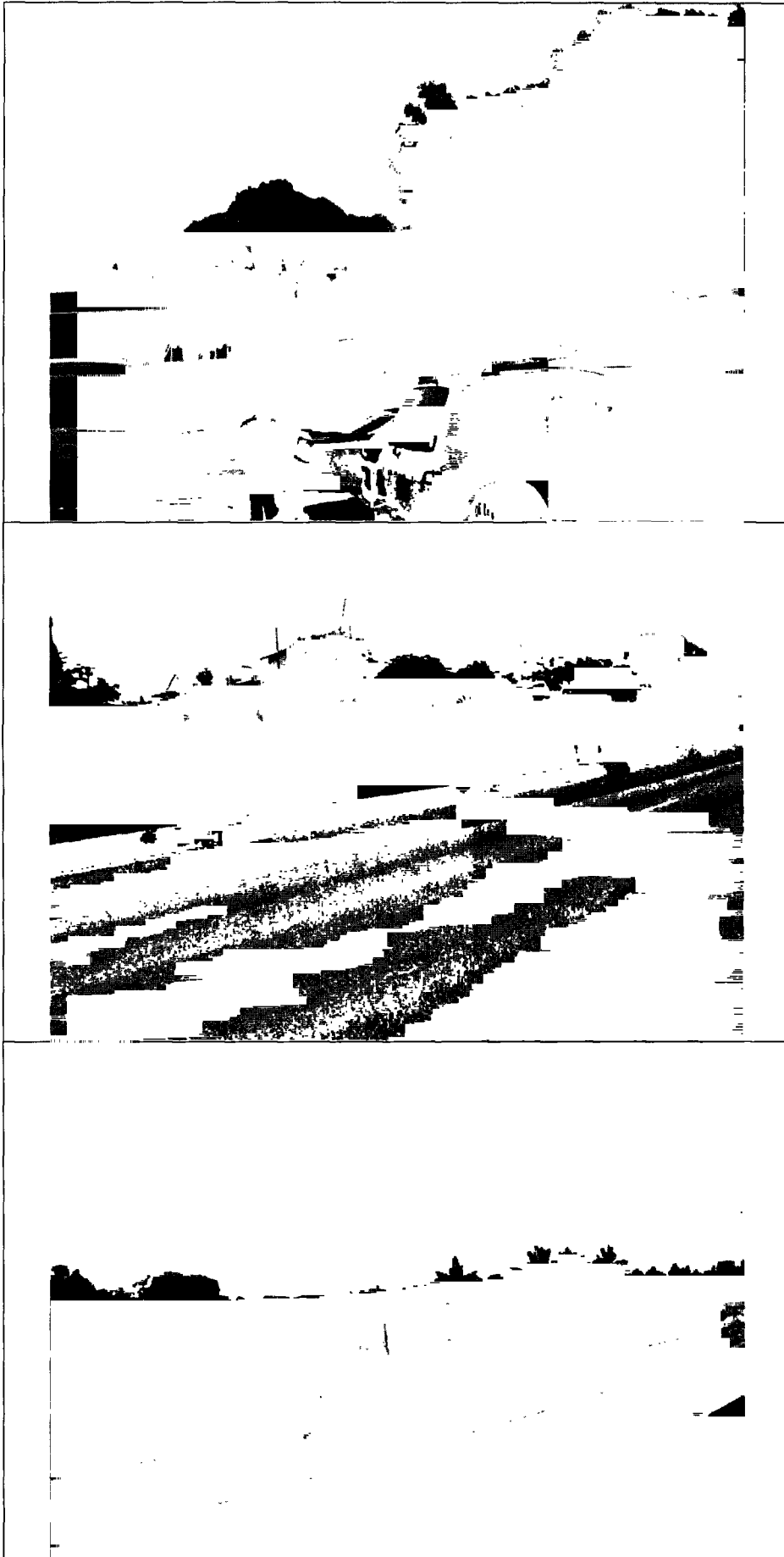

**VEGETATION
PHOTOGRAPHIC
REPORT**

Comments:

Figure 7- Typical Lawn
Vegetation– Morogoro Road -
Kimara

Figure 8 - Typical Lawn
Vegetation– Morogoro Road -
Kimara

Figure 9 - Typical Shade tree/lawn
at Morogoro Road – between
Ubungo and Kimara

Date: February, 2007
3/4

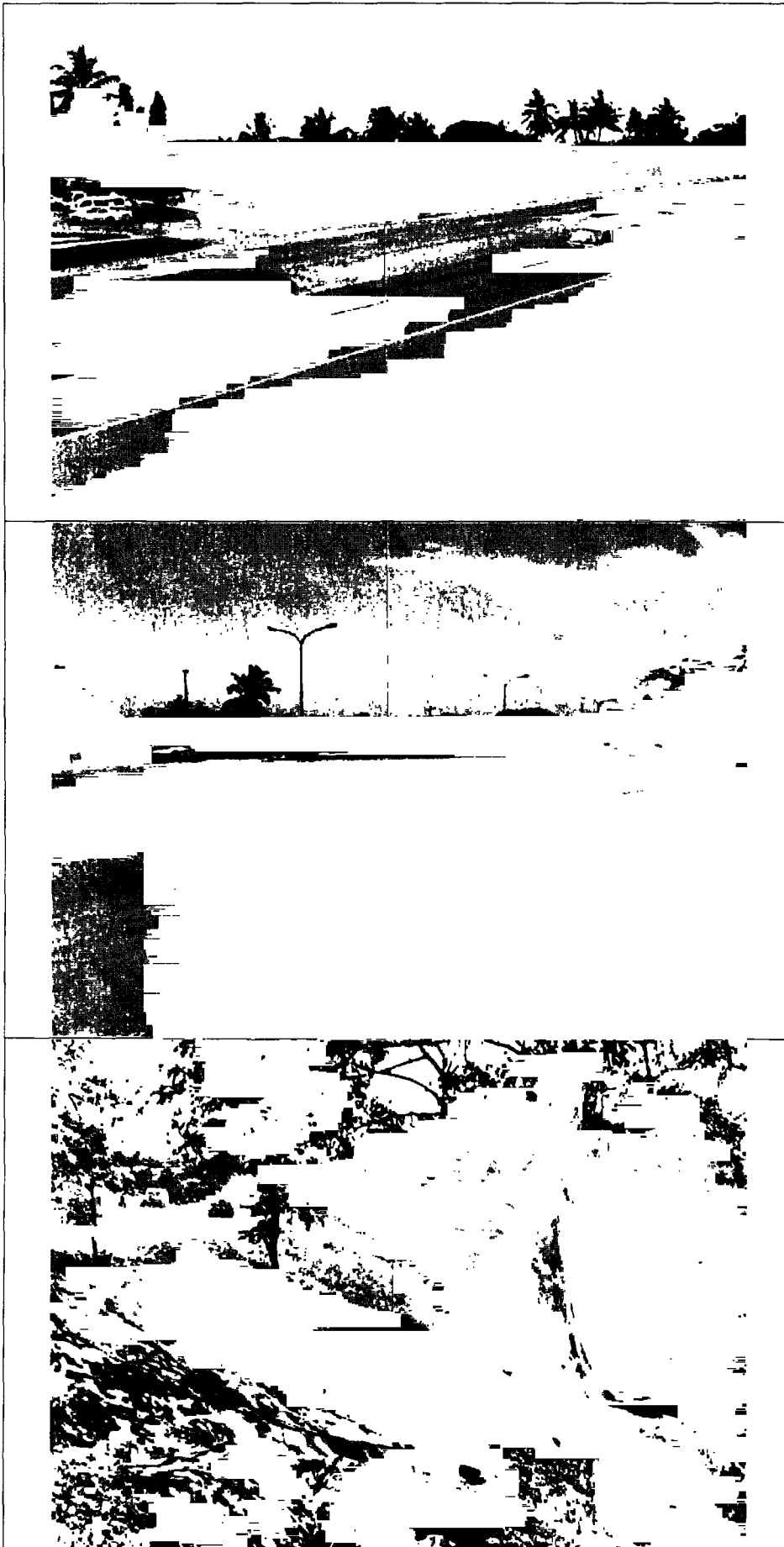

**VEGETATION
PHOTOGRAPHIC
REPORT**

Comments:

Figure 10- Typical Lawn/Shade
Vegetation at Kawawa Rd

Figure 11 - Typical Lawn
Vegetation at Kawawa Rd

Figure 12 - Typical Lawn
Vegetation at Kawawa Rd

Date: February, 2007
4/4

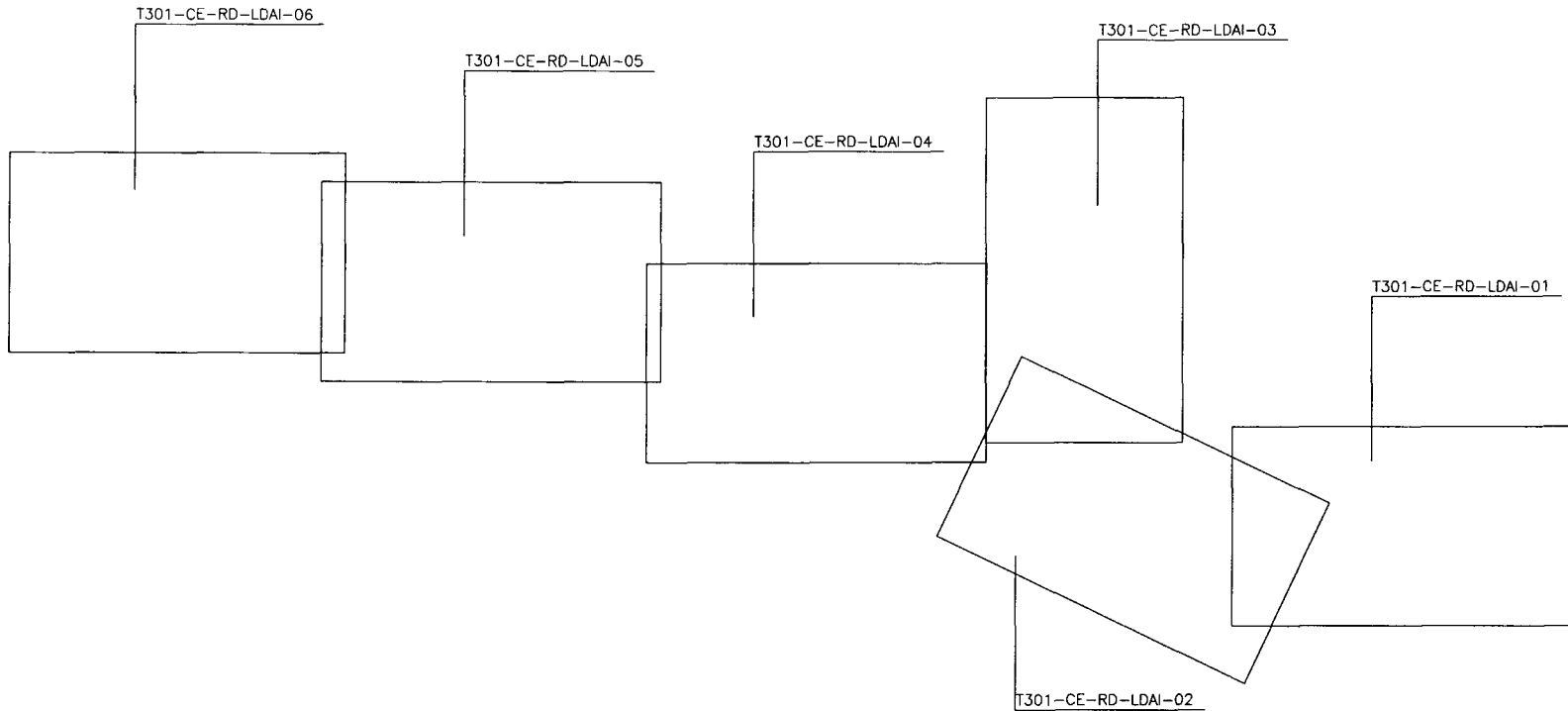

Client:



DAR ES SALAAM CITY COUNCIL
 P O Box 9084, Dar es Salaam, Tanzania
 Tel: + 255-22-2123551/6
 Email: cd@dcc.go.tz

Consultant:

LOGIT
 Logit Engenharia Consultiva Ltda
 Av. Espanha Matoso 690, 6 - Andar
 CEP 05433-000, Sao Paulo, Brazil
 In association with



inter-consult ltd
 P O Box 423, Dar es Salaam, Tanzania
 Tel: + 255-22-2772424/2772477
 Email: mail@interconsult-tz.com



RFP Consultoria e Participacoes Ltda.
 Rua Amador Brasilhara, 615
 CEP 04713-000, Sao Paulo, Brazil
 Email: jrc@rfpconsultoria.com.br

located by:	Project:
Surveyed by: Juliana C. Antunes	DAR RAPID TRANSIT (DART)
Designed by:	Subject:
Drawn by: Fabrizia Oliverii	LAND USE IDENTIFICATION DIRECT AREA OF INFLUENCE - DA
Checked by:	
Approved by:	Date: January 2007
Scale: none	Dwg No. T301-CE-RD-LDAI-00 REV 00

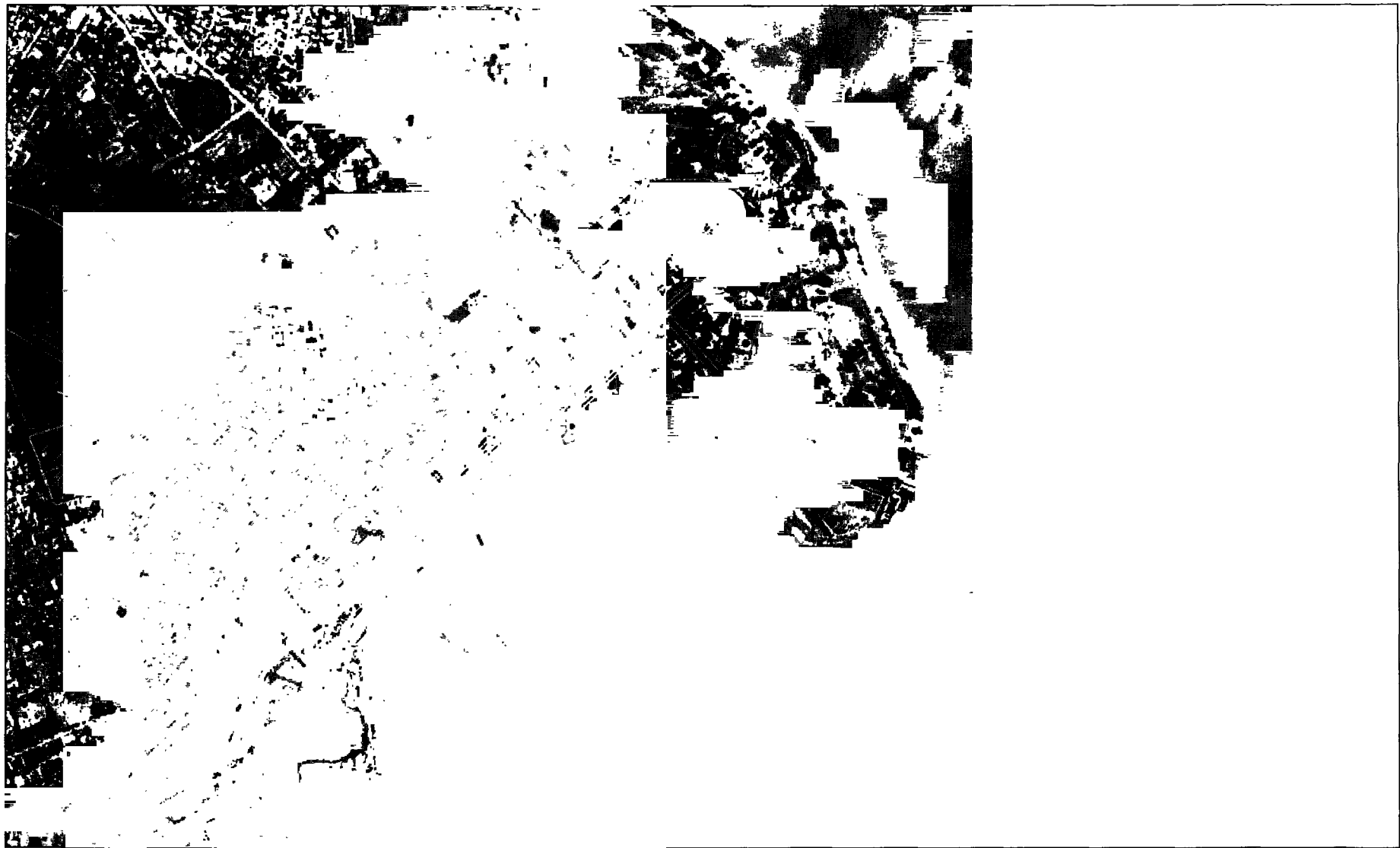

Client:



DAR ES SALAAM CITY COUNCIL
 P O Box 9084, Dar es Salaam, Tanzania
 Tel: + 255-22-2123551/6
 Email: cd@dcc.go.tz

Consultant:



Logit Engenharia Consultiva Ltda
 Av. Esplanada Motim 880, 8. andar
 CEP: 04413-000, São Paulo, Brazil

in association with
inter-consult ltd

P O Box 423, Dar es Salaam, Tanzania
 Tel: + 255-22-272426/272477
 Email: info@interconsult-ltd.com



JCP Consultoria e Participações Ltda
 Rua América Brasileira, 815
 CEP: 04718-000, São Paulo, Brazil
 Email: jcp@jcpconsultoria.com.br

LEGEND:

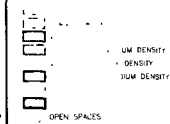

1 GOVERNMENT/INSTITUTIONAL BUILDINGS
2 RELIGIOUS SITE
3 SCHOOLS
4 HOSPITALS
P POLICE QUARTERS
CC COMMERCIAL CENTERS
CH COMMERCIAL HOTELS
CM MARKET

H HEAVY INDUSTRY
L LIGHT INDUSTRY
ST SUBSTATION TANECSO

located by	Project:
Surveyed by: Juliana C. Antunes	DAR RAPID TRANSIT (DART)
Designed:	Subject:
Drawn by: Fabrícia Oliveira	LAND USE IDENTIFICATION DIRECT AREA OF INFLUENCE - DAI
Checked by:	
Approved by	Date: January 2007
Scale: 1:1000	Dwg No: T301-CE-RD-LDAI-01 REV 00



Client:



DAR ES SALAAM CITY COUNCIL
 P O Box 9084, Dar es Salaam, Tanzania
 Tel: + 255-22-2123551/6
 Email: cd@dcc.go.tz

Consultant:



Logit Engenharia Consultiva Ltda
 Av. Lacerda Moraes 490, 6. andar
 CEP 05423-000, São Paulo, Brazil

In association with
inter-consult ltd

P.O. Box 423, Dar es Salaam, Tanzania
 Tel: + 255-22-2774024/2774977
 Email: m@interconsult-ltd.com





JGP Consultoria e Participações Ltda
 Rua América Brasileira, 515
 CEP 04715-003, São Paulo, Brazil
 Email: jgp@jgpconsultoria.com.br

LEGEND:

	1 GOVERNMENT/INSTITUTIONAL BUILDINGS		H HEAVY INDUSTRY
	2 RELIGIOUS SITE		L LIGHT INDUSTRY
	3 SCHOOLS		ST SUBSTATION (ANESCO)
	4 HOSPITALS		
	P POLICE QUARTERS		
	CC COMMERCIAL CENTER		
	CH COMMERCIAL HOTELS		
	CM MARKET		
	HIGH DENSITY		
	MEDIUM DENSITY		
	LOW DENSITY		
	URBAN DENSITY		

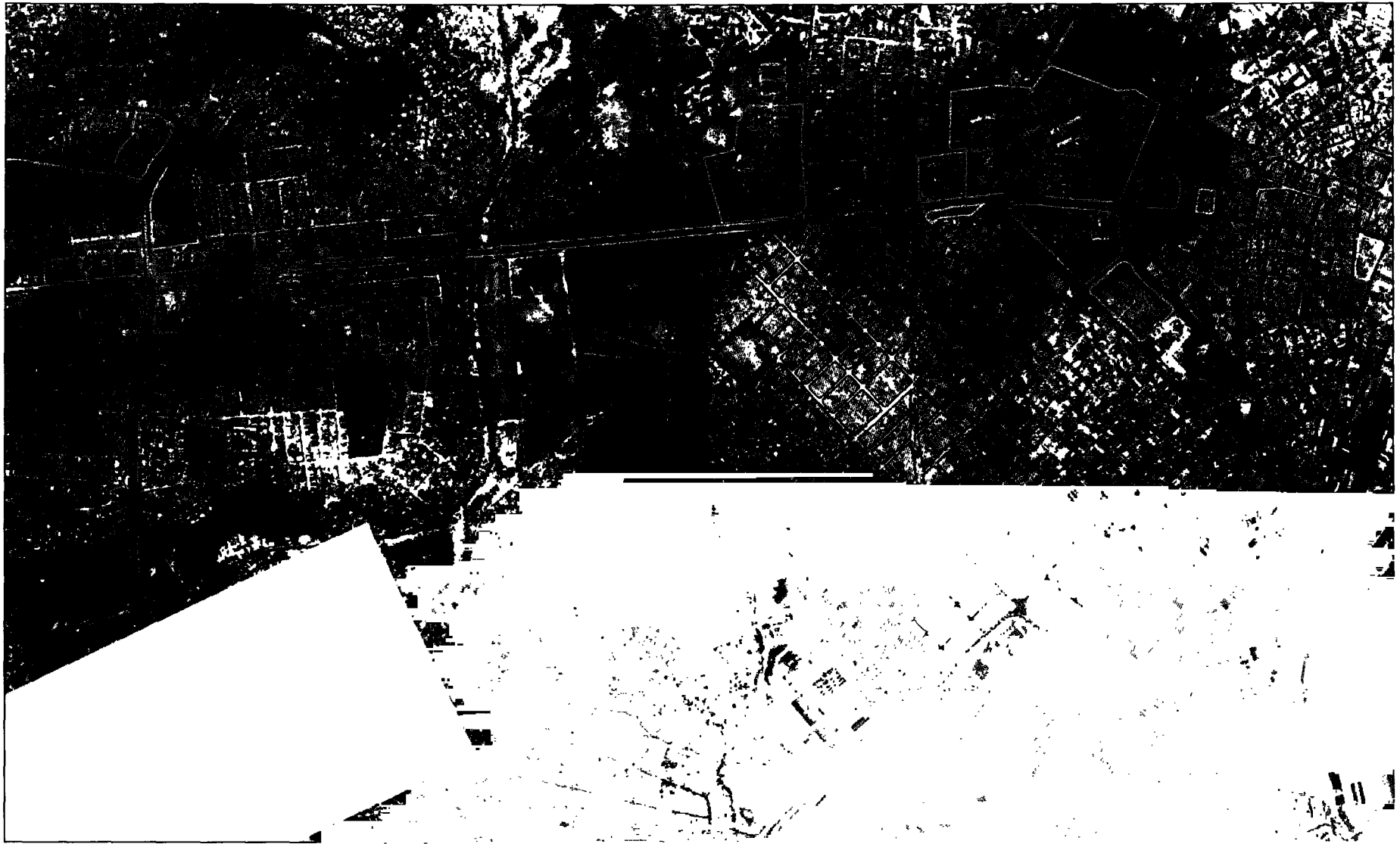
located by:	Project		
Surveyed by: Juliano C. Antunes	DAR RAPID TRANSIT (DART)		
Designed:	Subject:		
Drawn by: Fabrizio Oliveriu	LAND USE IDENTIFICATION DIRECT AREA OF INFLUENCE - DAI		
Checked by:			
Approved by:	Date:	January 2007	
Scale:	1:10000	Dwg No:	T301-CE-RD-LDAI-02
		REV	00













Client:

DAR ES SALAAM CITY COUNCIL
 P O Box 9084, Dar es Salaam, Tanzania
 Tel: + 255-22-2123551/6
 Email: cd@dcc.go.tz

Consultant:
LOGIT Logit Engenharia Consultiva Ltda
 Av. Euzébio Mattoso 690, 6 Andar
 CEP 05423-900, São Paulo, Brazil
 In association with

inter-consult ltd
 P O Box 423, Dar es Salaam, Tanzania
 Tel: + 255-22-2772424/2772477
 Email: mail@interconsult-tz.com

 UGP Consultoria e Participações Ltda
 Rua Andréia Brasilhava, 515
 CEP 04715-905, São Paulo, Brazil
 Email: ugp@uconsultoria.com.br

LEGEND:

	1 GOVERNMENT/INSTITUTIONAL BUILDINGS		H HEAVY INDUSTRY
	2 RELIGIOUS SITE		L LIGHT INDUSTRY
	3 SCHOOLS		ST SUBSTATION TANESCO
	4 HOSPITALS		
	P POLICE QUARTERS		
	CC COMMERCIAL CENTER		
	CH COMMERCIAL HOTELS		
	CM MARKET		

located by:
 Surveyed by: Juliana C. Antunes
 Designed by:
 Drawn by: Fabrizio Oliveria
 Checked by:
 Approved by:
 Scale: 1:1000

Project
DAR RAPID TRANSIT (DART)
 Subject:
 LAND USE IDENTIFICATION
 DIRECT AREA OF INFLUENCE - DAI
 Date: January 2007
 Drg No T301-CE-RD-LDAI-02 REV 00

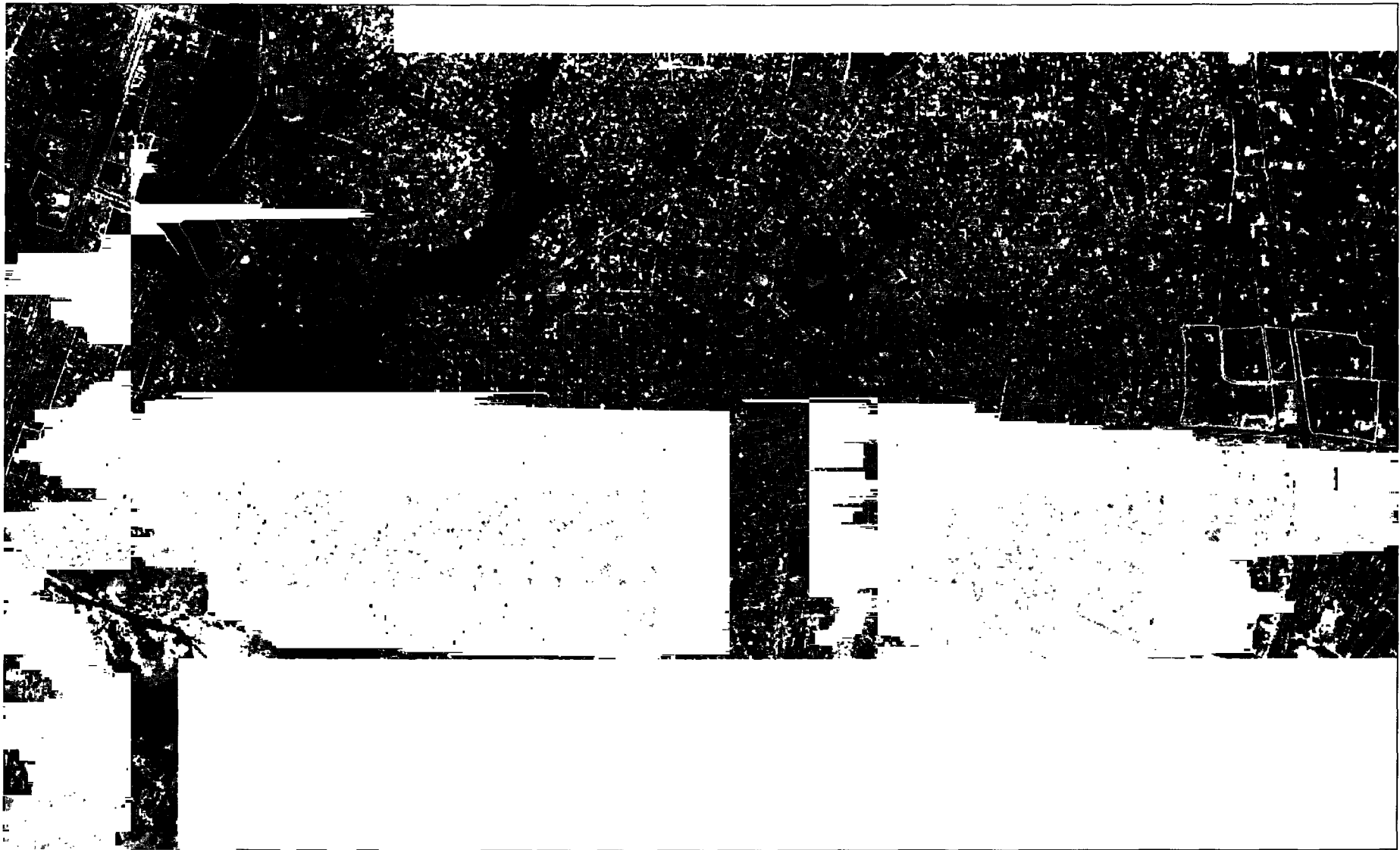

Client:



DAR ES SALAAM CITY COUNCIL
 P O Box 9084, Dar es Salaam, Tanzania
 Tel: + 255-22-2123551/6
 Email: cd@dcc.go.tz

Consultant:

LOGIT Logit Engenharia Consultiva Ltda
 Av. Lamer de Moraes 900, 8. andar
 CEP 05423-000, São Paulo, Brazil



inter-consult ltd
 P. O. Box 423, Dar es Salaam, Tanzania
 Tel. + 255-22-272424/272423
 Email: mo@interconsult-tz.com



JCP Consultoria e Participações Ltda
 Rua Andrade Brilhante, 615
 CEP 04716-003, São Paulo, Brazil
 Email: jcp@jcpconsultoria.com.br

LEGEND:

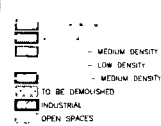

- 1 GOVERNMENT INSTITUTIONAL BUILDINGS
- 2 RELIGIOUS SITE
- 3 SCHOOLS
- 4 HOSPITALS
- P POLICE QUARTERS
- CC COMMERCIAL CENTER
- CH COMMERCIAL HOTELS
- CM MARKET

- H HEAVY INDUSTRY
- L LIGHT INDUSTRY
- ST SUBSTATION TRANSFORMER

located by:	Project: DAR RAPID TRANSIT (DART)		
Surveyed by: Juliana C. Antunes	Subject: LAND USE IDENTIFICATION DIRECT AREA OF INFLUENCE - DAI		
Designed:	Checked by:		
Drawn by: Fabrizia Oliveria	Date:	January 2007	
Approved by:	Scale:	1:10000	Drwg No: T301-CE-RD-LDAI-03 REV 00

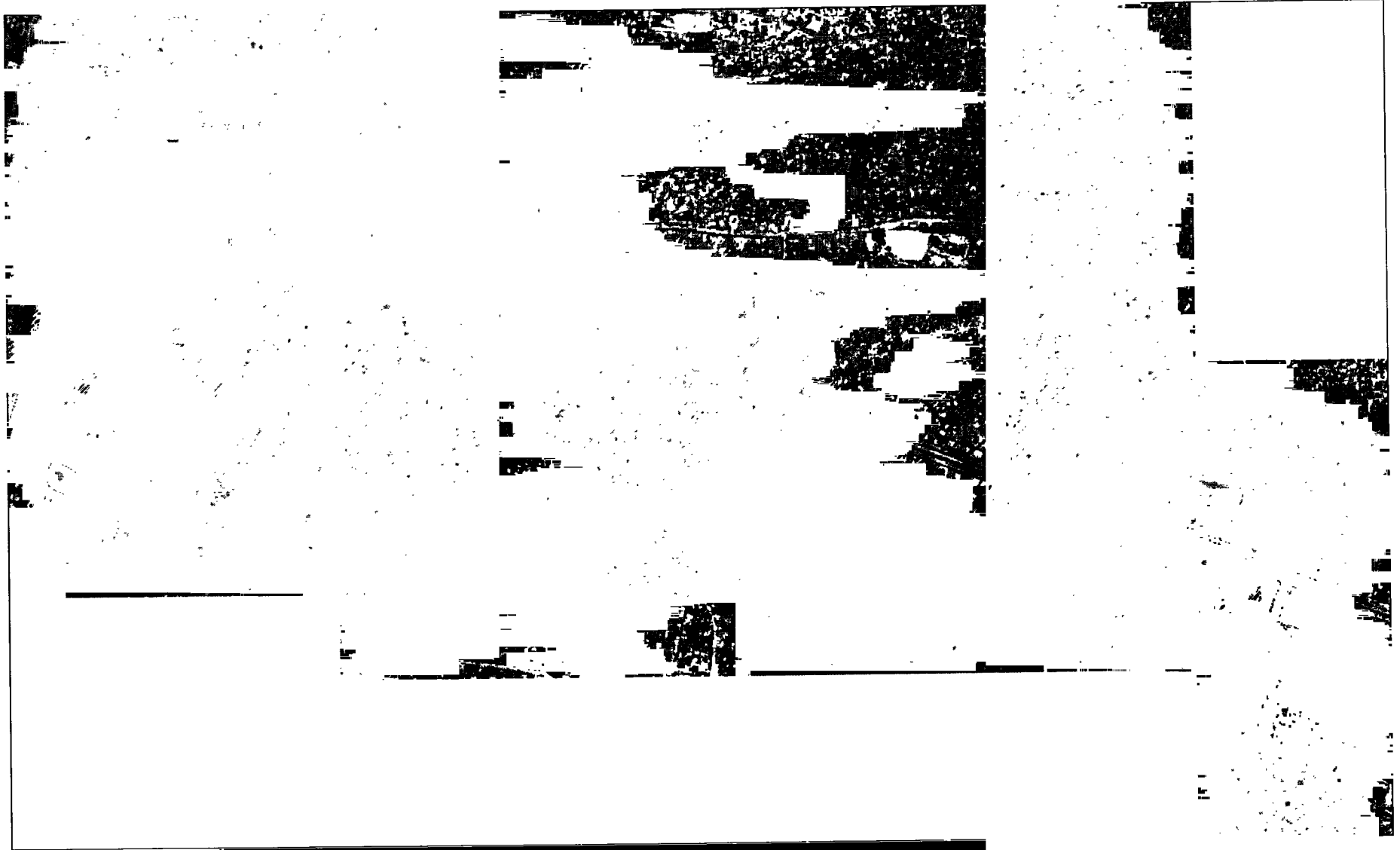

Client:



DAR ES SALAAM CITY COUNCIL
 P O Box 9084, Dar es Salaam, Tanzania
 Tel: + 255-22-2123551/6
 Email: cd@dcc.go.tz

Consultant:



Logit Engenharia Consultiva Ltda
 Av. Europa, Morcego 890, 6. Andar
 CEP 04613-000, São Paulo, Brazil

In association with



inter-consult ltd
 P O Box 423, Dar es Salaam, Tanzania
 Tel: + 255-22-272424/272477
 Email: info@interconsult-tz.com



JGP Consultoria e Participações Ltda
 Rua América Brasileira 615
 CEP 04718-003, São Paulo, Brazil
 Email: jgp@jgpconsultoria.com.br

LEGEND:





- SHMS
- MIXED USE - HIGH DENSITY
 - MIXED USE - MEDIUM DENSITY
 - MIXED USE - LOW DENSITY
 - RESIDENTIAL - MEDIUM DENSITY
 - TO BE DEMOLISHED

- 1 GOVERNMENT/INSTITUTIONAL BUILDINGS
- 2 RELIGIOUS SITE
- 3 SCHOOLS
- 4 HOSPITALS
- P POLICE QUARTERS
- CC COMMERCIAL CENTER
- CH COMMERCIAL HOTELS
- CM MARKET

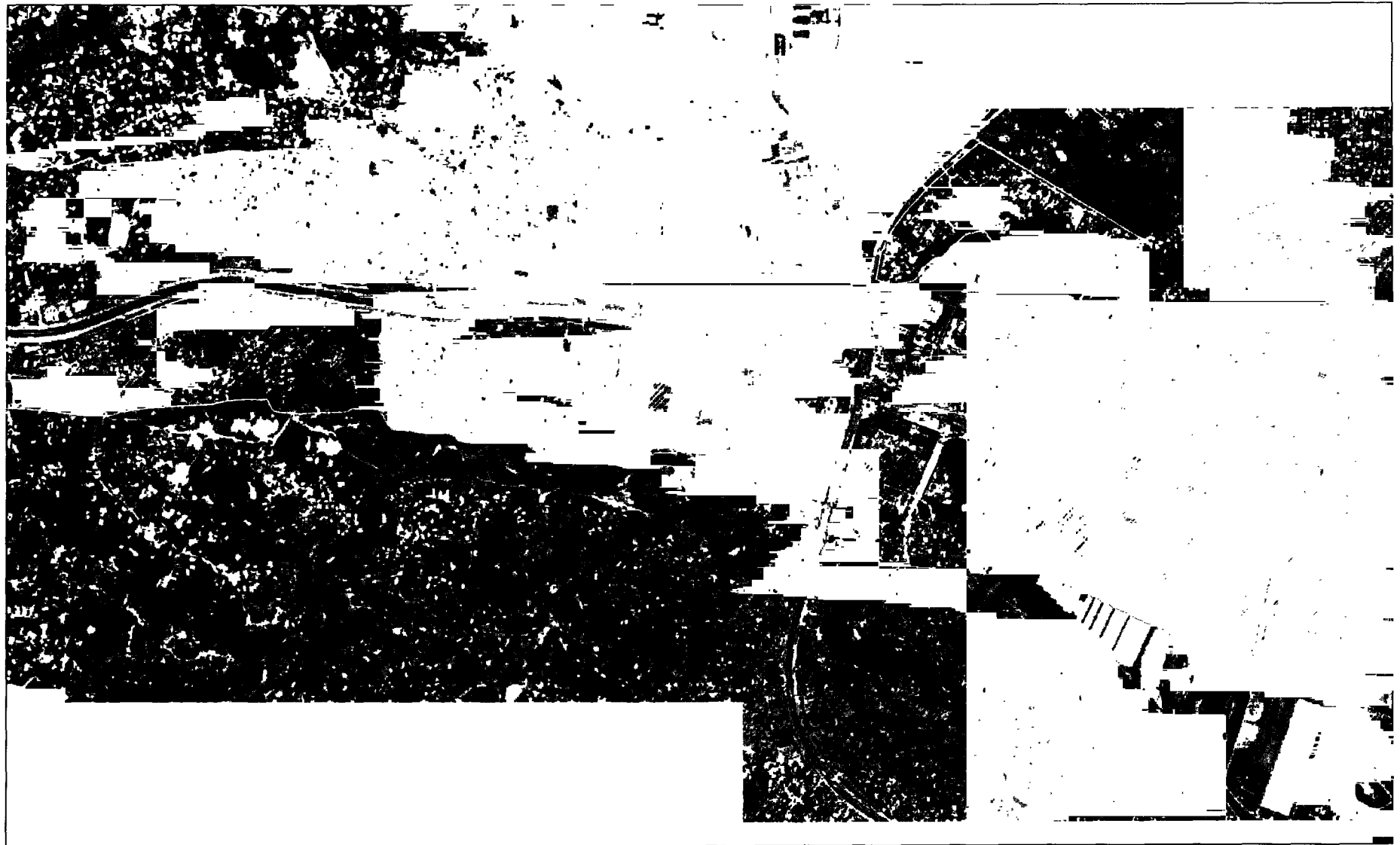
- H HEAVY INDUSTRY
- L LIGHT INDUSTRY
- ST SUBSTATION (INSECO)

located by:	Project		
Surveyed by: Juliana C. Antunes	DAR RAPID TRANSIT (DART)		
Designed:	Subject:		
Drawn by: Fabrizia Oliveri	LAND USE IDENTIFICATION DIRECT AREA OF INFLUENCE - DAI		
Checked by:	Date:	January 2007	
Approved by:	Scale:	1:10000	REV 00
	Drw No.	TJ301-CE-RD-LDAI-04	

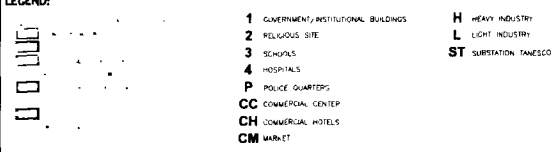

Client:  DAR ES SALAAM CITY COUNCIL P O Box 9084, Dar es Salaam, Tanzania Tel: + 255-22-2123551/6 Email: cd@dcc.go.tz	Consultant:  Logit Engenharia Consultiva Ltda Av. Lacerda, Maracanã, 890, 8. Andar CEP 05423-000, São Paulo, Brazil in association with  inter-consult ltd P O Box 423, Dar es Salaam, Tanzania Tel: + 255-22-271424/272477 Email: info@interconsult-tz.com  AGP Consultoria e Participações Ltda Rua Andréia Brodowski, 815 CEP 04719-003, São Paulo, Brazil Email: info@agpconsultoria.com.br	LEGEND: 	located by: Surveyed by: Juliana C. Antunes	Project: DAR RAPID TRANSIT (DART)	
			Designed: Drawn by: Fabrizio Oliverio	Subject: LAND USE IDENTIFICATION DIRECT AREA OF INFLUENCE - DAI	
Checked by: Approved by:		Date: January 2007	Scale: 1:10000	Org No.: T301-CE-RD-LDAI-05	REV 00

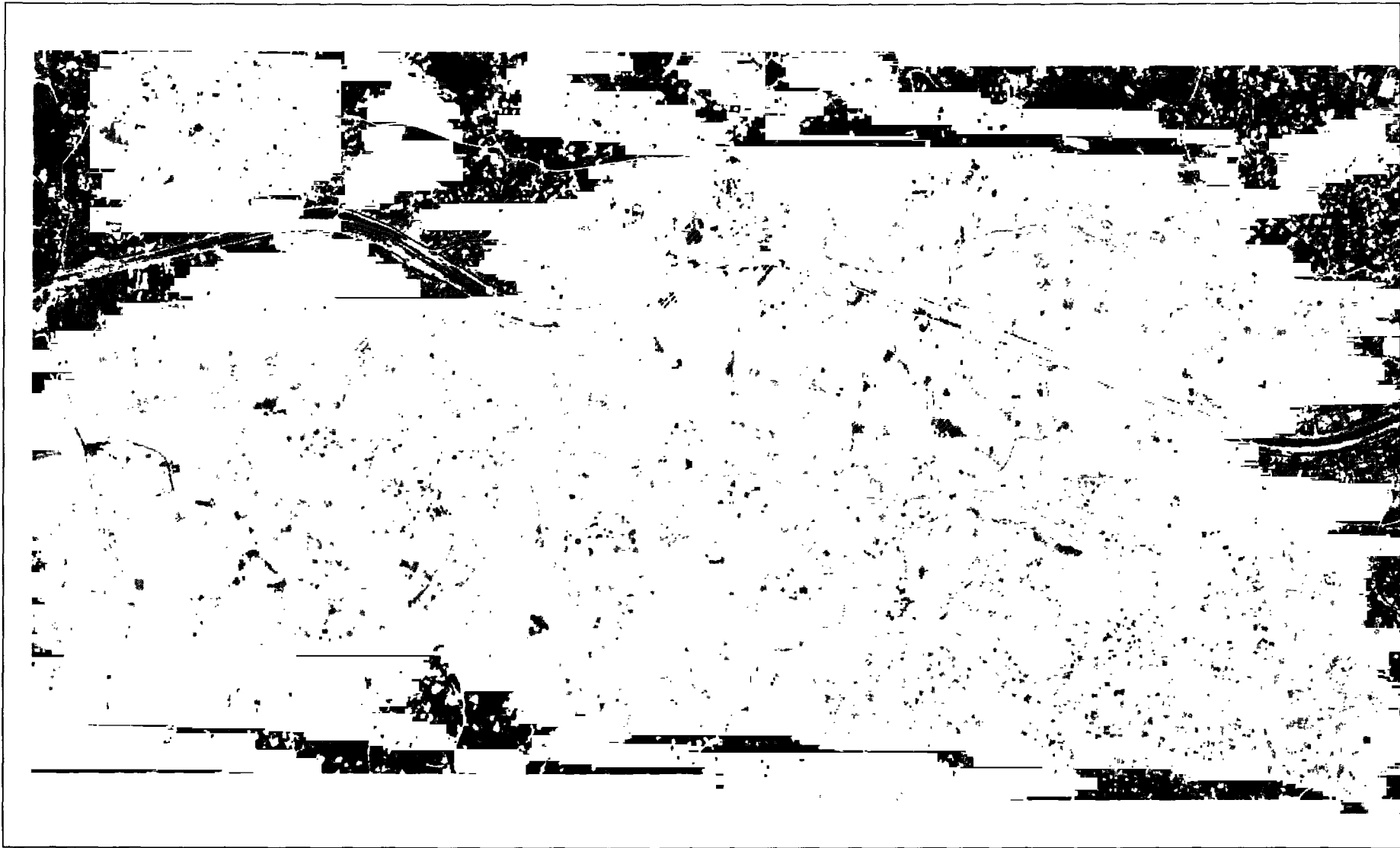

Client:



DAR ES SALAAM CITY COUNCIL
 P O Box 9084, Dar es Salaam, Tanzania
 Tel: + 255-22-2123551/6
 Email: cd@dcc.go.tz

Consultant:



Logit Engenharia Consultiva Ltda
 Av. Lusitano, Morro 890, 6. Andar
 CEP 05423-000, São Paulo, Brazil
 In association with



inter-consult ltd
 P O Box 423, Dar es Salaam, Tanzania
 Tel: + 255-22-2772424/2772477
 Email: info@interconsult-iz.com



JEP Consultoria e Participações Ltda
 Rua Antônio Brandão, 815
 CEP 04715-003, São Paulo, Brazil
 Email: jep@jepconsulting.com.br

LEGEND:

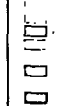

LOW DENSITY
 + DENSITY
 HIGH DENSITY

- 1 GOVERNMENT, INSTITUTIONAL BUILDINGS
- 2 RELIGIOUS SITE
- 3 SCHOOLS
- 4 HOSPITALS
- P POLICE QUARTERS
- CC COMMERCIAL CENTER
- CH COMMERCIAL HOTELS
- CM MARKET

- H HEAVY INDUSTRY
- L LIGHT INDUSTRY
- ST SUBSTATION, TALESCO

located by:	Project:
Surveyed by: Juliana C. Antunes	DAR RAPID TRANSIT (DART)
Designed by:	Subject:
Drawn by: Fabrizia Oliverii	LAND USE IDENTIFICATION DIRECT AREA OF INFLUENCE - DAI
Checked by:	Date: January 2007
Approved by:	Drig No. T301-CE-RD-LDAI-06 PEV 00
Scale: 1:10000	

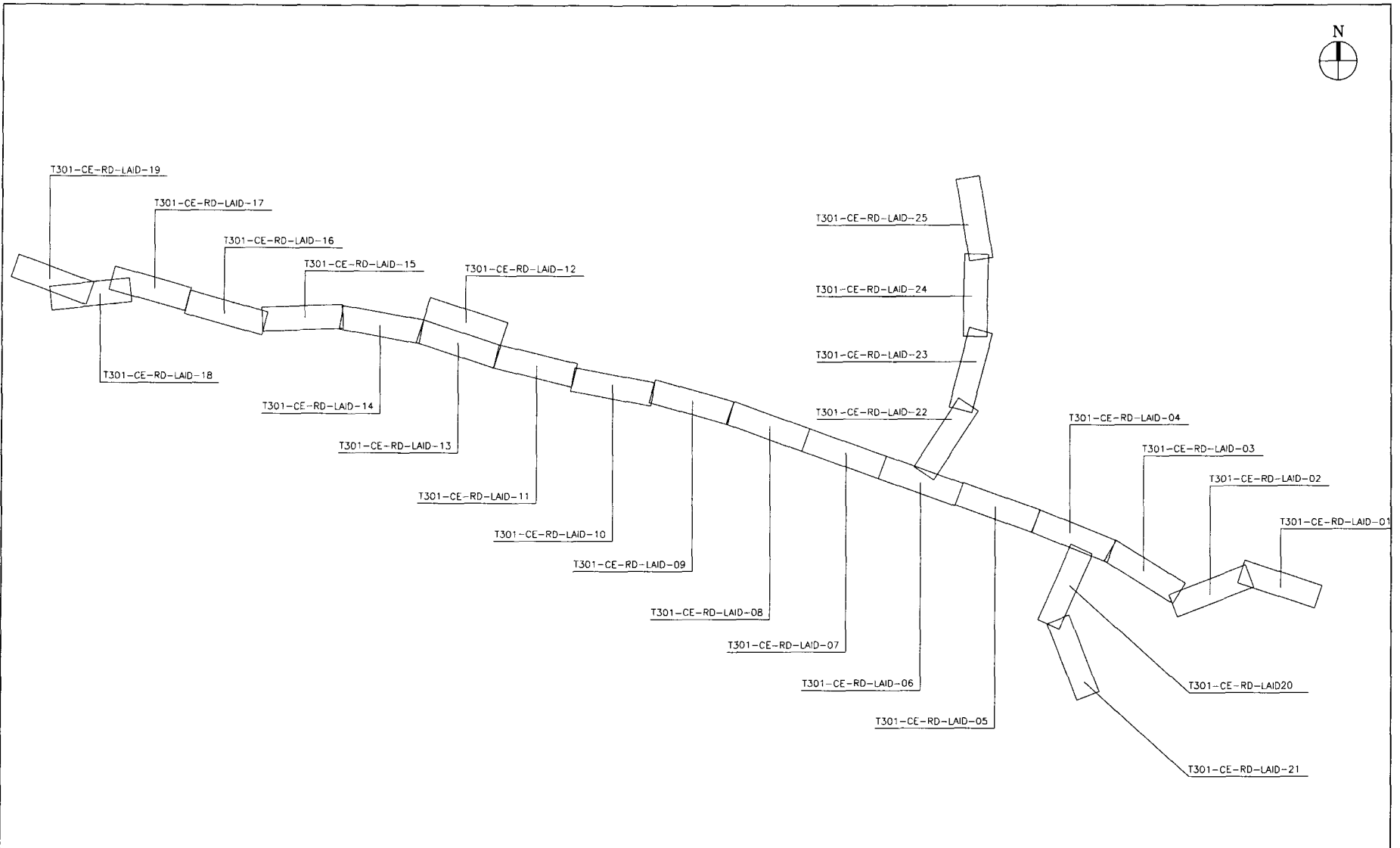

Client:

DAR ES SALAAM CITY COUNCIL
 P O Box 9084, Dar es Salaam, Tanzania
 Tel: + 255-22-2123551/6
 Email: cd@dcc.go.tz

Consultant:
LOGIT
 Logit Engenharia Consultiva Ltda
 Av. Espanha, bairro 590, 6 - Andar
 CEP 02453-003, São Paulo, Brazil
 in association with:
inter-consult ltd
 P O Box 423, Dar es Salaam, Tanzania
 Tel: + 255-22-2772424/2772477
 Email: info@interconsult-tz.com

KIP Consultoria e Participações Ltda.
 Rua Antônio Brilhante, 813
 CEP 04715-003, São Paulo, Brazil
 Email: kip@ipconsultoria.com.br

located by:	Project:
Surveyed by: Juliana C. Antunes	DAR RAPID TRANSIT (DART)
Designed:	Subject:
Drawn by: Fabrizia Oliverii	LAND USE IDENTIFICATION DIRECT AFFECTED AREA - DAA
Checked by:	
Approved by:	Date: January 2007
Scale: none	Drw No. T301-CE-RD-LAID-00
	REV 00

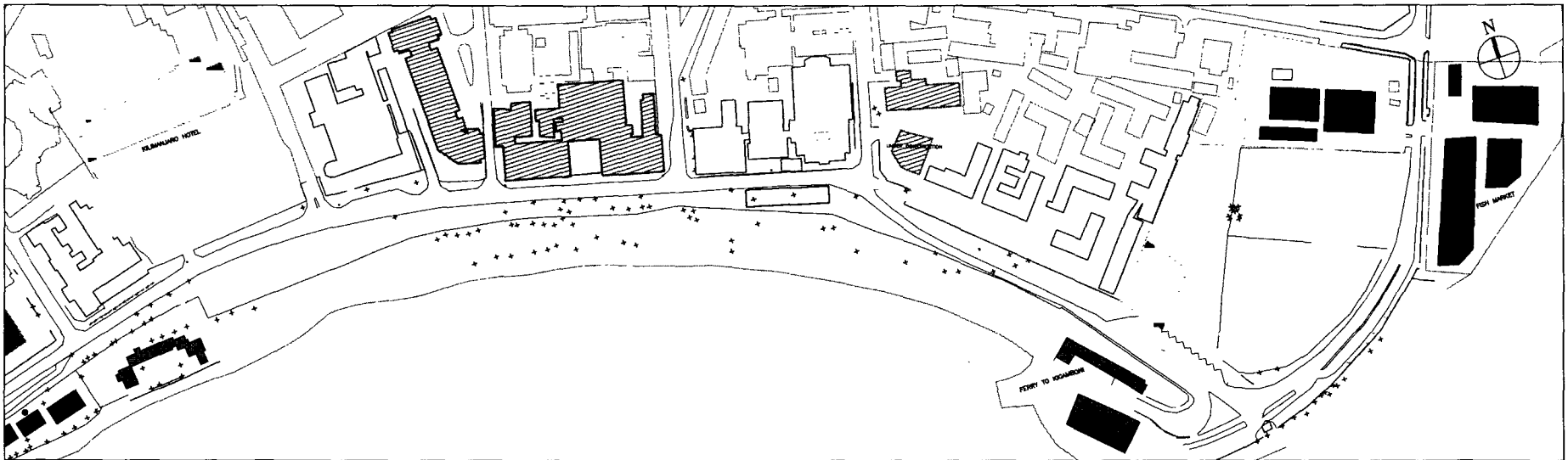
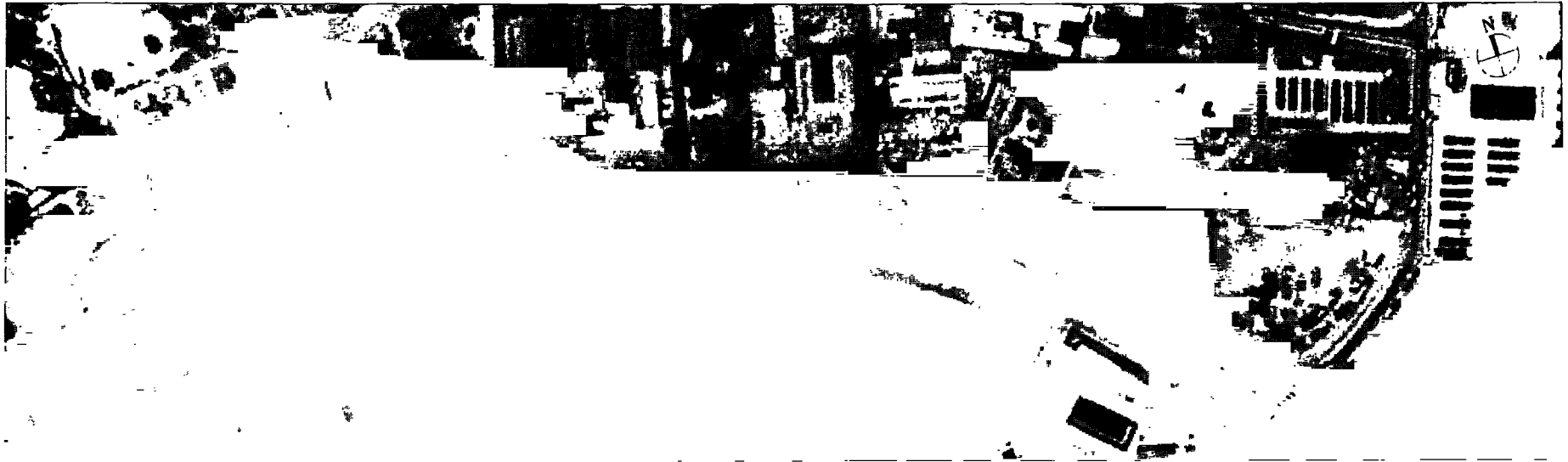

Client:



DAR ES SALAAM CITY COUNCIL
 P O Box 9084, Dar es Salaam, Tanzania
 Tel: + 255-22-2123551/6
 Email: cd@dcc.go.tz

Consultant:



LOGIT Logit Engenharia Consultiva Ltda
 Av. Llanillo Nelson 800, 6. Floor
 CEP 05423-000, São Paulo, Brazil



inter-consult ltd
 P. O. Box 423, Dar es Salaam, Tanzania
 Tel: + 255-22-2776424/2776477
 Email: info@interconsult-tz.com



XIP Consultoria e Participações Ltda.
 Rua Antônio Brás, 813
 CEP 04115-003, São Paulo, Brazil
 Email: xp@xpconsultoria.com.br

LEGEND:



- + TREES
- ▲ ABUTTING PROPERTIES
- ▭ RESIDENTIAL PROPERTIES (at ground floor)
- ▨ COMMERCIAL ACTIVITY TYPES:
 - ▨ RESTAURANT/BAR/FOOD & LEISURE/HOTEL
 - ▨ VEHICLE RELATED SERVICES (EXCLUDING PETROL STATIONS)
 - ▨ PETROL STATIONS
 - ▨ OTHER RETAIL OR SERVICES (INCLUDING BANKS AND FINANCIAL INSTITUTIONS AND MARKETS)
 - ▨ RELIGIOUS BUILDINGS
 - ▨ PUBLIC/INSTITUTIONAL BUILDINGS (INCLUDING SCHOOLS)
 - ▨ INDUSTRIAL
 - ▨ OTHER (HOSPITALS, FIRE STATION, ETC)

- CLASSIFICATION BY HEIGHT:
- ▭ 1 OR 2 STOREY BUILDINGS
 - ▨ 3 OR 4 STOREY BUILDINGS
 - ▨ 5 OR MORE STOREY BUILDINGS
 - ▨ UPPER STOREY PREDOMINANT USE
 - ▨ RESIDENTIAL
 - ▨ COMMERCIAL

- USES INSIDE THE RIGHT-OF-WAY (ROW)
- ▲ AREA OCCUPIED BY BARS AND RESTAURANTS
 - ▨ OTHER ROW AREAS OCCUPIED BY ABUTTING COMMERCE
 - ▨ ROW AREAS OCCUPIED BY STREET VENDORS (PORTABLE VENDORS OR EQUIVALENT)
 - DAKADALA STOPS
 - TAXI SPOTS
 - TRUCK PARKING AREAS
 - OTHER PARKING AREAS (INDICATE USE)
 - OTHER (INDICATE USE)

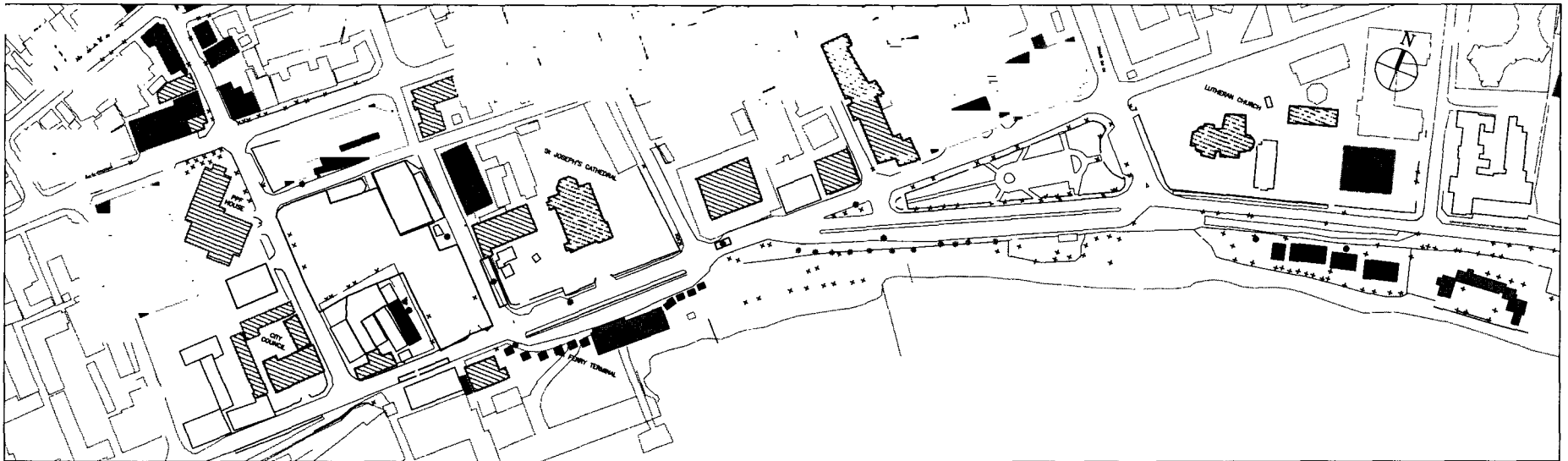
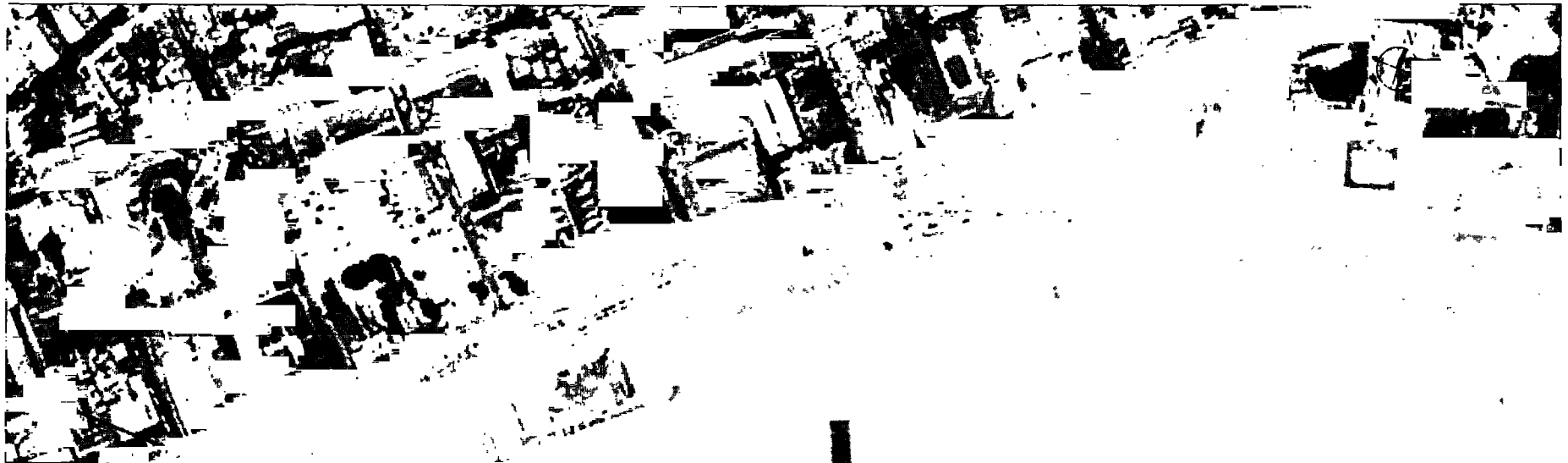
located by:	Project:
Surveyed by: Juliana C. Antunes	DAR RAPID TRANSIT (DART)
Designed:	Subject:
Drawn by: Fabrizia Oliveri	LAND USE IDENTIFICATION
Checked by:	DIRECT AFFECTED AREA - DAA
Approved by:	Date: January 2007
Scale: 1:2500	Org No. T301-GE-RD-LAID-01
	REV 00



Client:  DAR ES SALAAM CITY COUNCIL P O Box 9084, Dar es Salaam, Tanzania Tel: + 255-22-2123551/6 Email: cd@dcc.go.tz	Consultant: LOGIT Logit Engenharia Consultiva Ltda Av. Lins de Vasconcelos 890, 6 - Andar CEP 04333-000, São Paulo, Brazil In association with inter-consult ltd P O Box 453, Dar es Salaam, Tanzania Tel: + 255-22-2772424/2772477 Email: info@interconsult-tz.com  ADP Consultoria e Participações Ltda. Rua Arco do Boqueirão, 815 CEP 04715-003, São Paulo, Brazil Email: info@adpconsultoria.com.br	LEGEND: ADJUTING PROPERTIES: * TREES ■ RESIDENTIAL PROPERTIES (at ground floor) COMMERCIAL ACTIVITY TYPES: ■ RESTAURANT/CAFÉ/FOOD & LEISURE/HOTEL ■ VEHICLE RELATED SERVICES (EXCLUDING PETROL STATIONS) ■ PETROL STATIONS ■ OTHER RETAIL OR SERVICES (INCLUDING BANKS AND FINANCIAL INSTITUTIONS AND MARKETS) ■ RELIGIOUS BUILDINGS ■ PUBLIC/INSTITUTIONAL BUILDINGS (INCLUDING SCHOOLS) ■ INDUSTRIAL ■ OTHER (HOSPITALS, FIRE STATION, ETC)	CLASSIFICATION BY HEIGHT: ■ 1 OR 2 STOREY BUILDINGS ■ 3 OR 4 STOREY BUILDINGS ■ 5 OR MORE STOREY BUILDINGS ■ LOW/3 STOREY PRISON/INMATE USE ■ RESIDENTIAL ■ COMMERCIAL	USES INSIDE THE RIGHT-OF-WAY (ROW) ■ AREA OCCUPIED BY BARS AND RESTAURANTS ■ OTHER ROW AREAS OCCUPIED BY ADJUTING COMMERCE ■ ROW AREAS OCCUPIED BY STREET VENDORS (PORTABLE VENDORS OR EQUIVALENT) ● DAKHLA STOPS ● DAKHLA PARKING AREAS ● TAXI SPOTS ● TRUCK PARKING AREAS ● OTHER PARKING AREAS (INDICATE USE) ● OTHER (INDICATE USE)	located by: Surveyed by: Juliana C. Antunes	Project: DAR RAPID TRANSIT (DART)
					Drawn by: Fabrizio Oliverii Checked by: Approved by: Scale: 1:2500	Subject: LAND USE IDENTIFICATION DIRECT AFFECTED AREA - DAA Date: January 2007 Drg No T301-CE-RD-LAID-02 REV 00

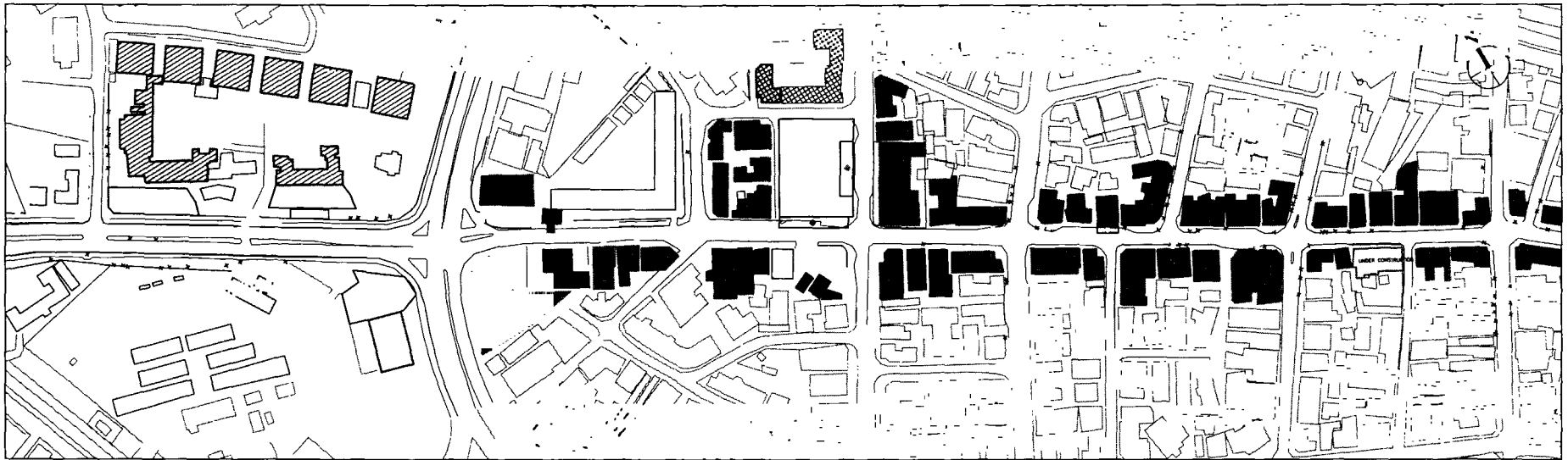

<p>Client:</p>  <p>DAR ES SALAAM CITY COUNCIL P O Box 9084, Dar es Salaam, Tanzania Tel: + 255-22-2123551/6 Email: cd@dcc.go.tz</p>	<p>Consultant:</p> <p>LOGIT Logit Engenharia Consultiva Ltda Av. Lúcio M. Soares 880, 4.º Andar CEP 04533-000, São Paulo, Brazil In association with inter-consult ltd P O Box 423, Dar es Salaam, Tanzania Tel: + 255-22-2772484/2772477 Email: info@interconsult-ltd.com</p> <p>REP Consultoria e Participações Ltda. Rua América Brasileira, 815 CEP 04715-000, São Paulo, Brazil Email: info@repconsultoria.com.br</p>	<p>LEGEND:</p> <p>● TREES</p> <p>▲ ABUTTING PROPERTIES:</p> <p>■ RESIDENTIAL PROPERTIES (at ground floor)</p> <p>■ COMMERCIAL ACTIVITY TYPES:</p> <p>■ RESTAURANT/BAR/FOOD & LEGURE/HOTEL</p> <p>■ VEHICLE RELATED SERVICES (EXCLUDING PETROL STATIONS)</p> <p>■ PETROL STATIONS</p> <p>■ OTHER RETAIL OR SERVICES (INCLUDING BANKS AND FINANCIAL INSTITUTIONS AND MARKETS)</p> <p>■ RELIGIOUS BUILDINGS</p> <p>■ PUBLIC/INSTITUTIONAL BUILDINGS (INCLUDING SCHOOLS)</p> <p>■ INDUSTRIAL</p> <p>■ OTHER (HOSPITALS, FIRE STATION, ETC)</p>	<p>CLASSIFICATION BY HEIGHT:</p> <p>■ 1 OR 2 STOREY BUILDINGS</p> <p>■ 3 OR 4 STOREY BUILDINGS</p> <p>■ 5 OR MORE STOREY BUILDINGS</p> <p>■ UPPER STOREY PREDOMINANT USE:</p> <p>■ RESIDENTIAL</p> <p>■ COMMERCIAL</p>	<p>USES INSIDE THE RIGHT-OF-WAY (ROW)</p> <p>▲ AREA OCCUPIED BY BARS AND RESTAURANTS</p> <p>■ OTHER ROW AREAS OCCUPIED BY ABUTTING COMMERCE</p> <p>■ ROW AREAS OCCUPIED BY STREET VENDORS (POWERCED)</p> <p>● ROW AREAS OCCUPIED BY FIXED/AUTHORIZED STREET VENDORS OR EQUIVALENT</p> <p>● DAKADALA STOPS</p> <p>● DAKADALA PARKING AREAS</p> <p>● TAXI SPOTS</p> <p>● TRUCK PARKING AREAS</p> <p>● OTHER PARKING AREAS (INDICATE USE)</p> <p>● OTHER (INDICATE USE)</p>	<p>located by:</p> <p>Surveyed by Juliana C. Antunes</p>	<p>Project:</p> <p>DAR RAPID TRANSIT (DART)</p>
					<p>Designed by:</p> <p>Drawn by: Fabrizio Oliveri</p> <p>Checked by:</p> <p>Approved by:</p> <p>Scale: 1:250</p>	<p>Subject:</p> <p>LAND USE IDENTIFICATION DIRECT AFFECTED AREA - DMA</p> <p>Date: January 2007</p> <p>Drg No. T301-CE-RD-LAID-03 REV 00</p>

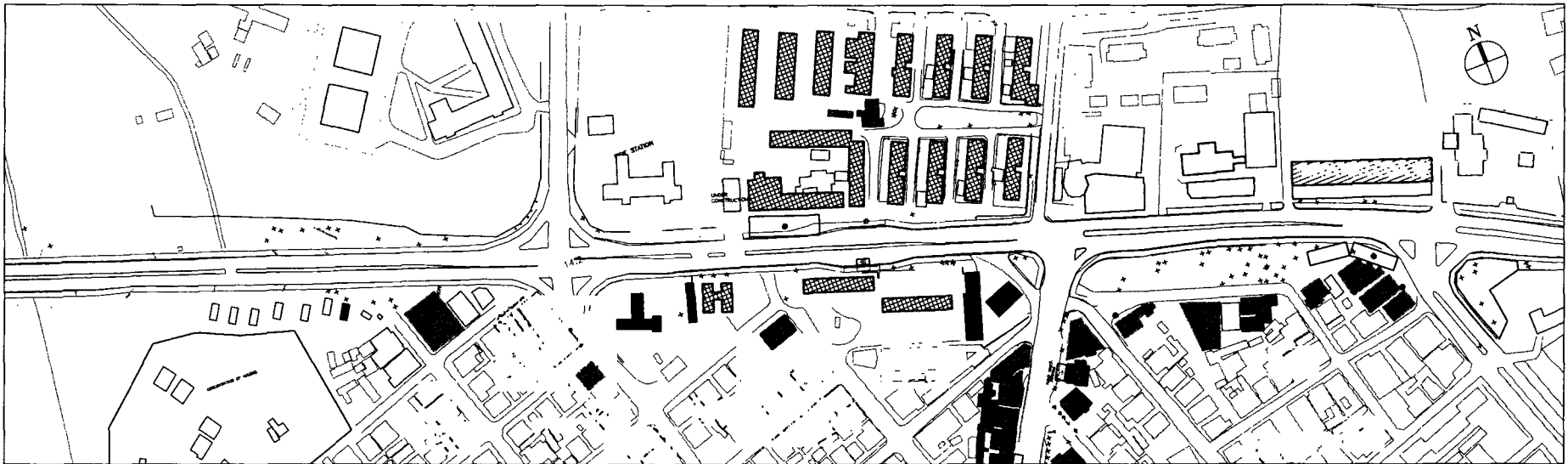
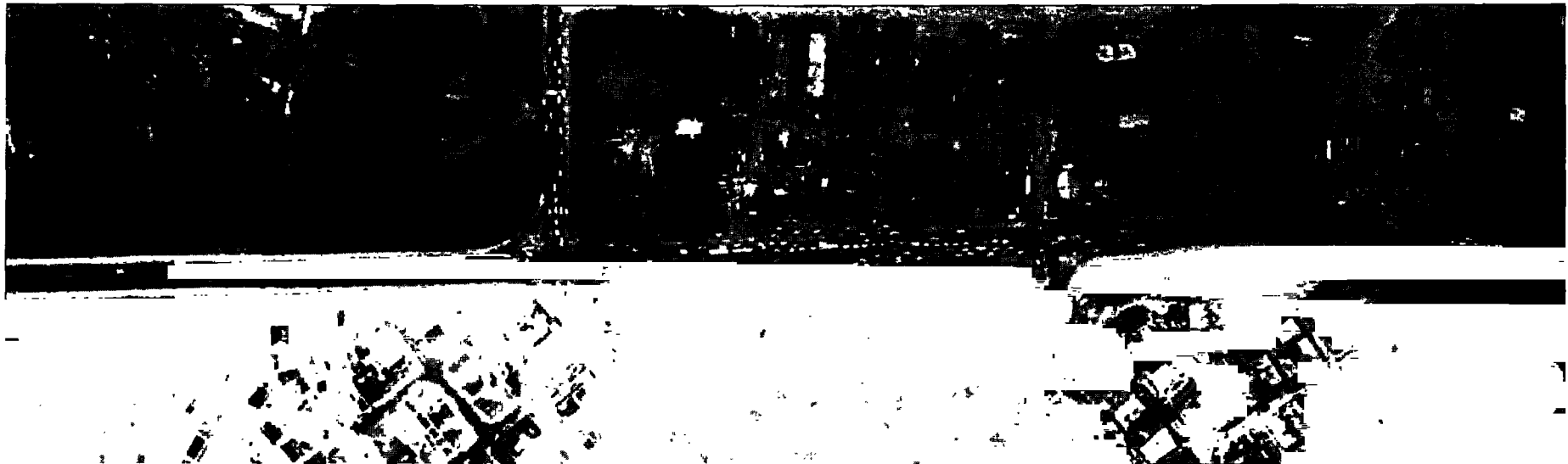

Client:

DAR ES SALAAM CITY COUNCIL
 P O Box 9084, Dar es Salaam, Tanzania
 Tel: + 255-22-2123551/6
 Email: cd@dcc.go.tz

Consultant:
LOGIT
 Logit Engenharia Consultiva Ltda
 Av. Lúcio Motta 680, 8. Andar
 CEP 05412-000, São Paulo, Brazil
 In association with
inter-consult ltd
 P O Box 423, Dar es Salaam, Tanzania
 Tel: + 255-22-2772424/2772477
 Email: info@interconsult-ltd.com

LEGEND:
 + TREES
ABUTTING PROPERTIES:
 ■ RESIDENTIAL PROPERTIES (at ground floor)
COMMERCIAL ACTIVITY TYPES:
 ■ RESTAURANT/BAR/FOOD & LEISURE/HOTEL
 ■ VEHICLE RELATED SERVICES (EXCLUDING PETROL STATIONS)
 ■ PETROL STATIONS
 ■ OTHER RETAIL OR SERVICES (INCLUDING BANKS AND FINANCIAL INSTITUTIONS AND MARKETS)
 ■ RELIGIOUS BUILDINGS
 ■ PUBLIC/INSTITUTIONAL BUILDINGS (INCLUDING SCHOOLS)
 ■ INDUSTRIAL
 ■ OTHER (HOSPITALS, FIRE STATION, ETC)

CLASSIFICATION BY HEIGHT:
 ■ 1 OR 2 STOREY BUILDINGS
 ■ 3 OR 4 STOREY BUILDINGS
 ■ 5 OR MORE STOREY BUILDINGS
UPPER STOREY PREDOMINANT USE:
 ■ RESIDENTIAL
 ■ COMMERCIAL

USES INSIDE THE RIGHT-OF-WAY (ROW)
 ■ AREA OCCUPIED BY BARS AND RESTAURANTS
 ■ OTHER ROW AREAS OCCUPIED BY ABUTTING COMMERCE
 ■ ROW AREA OCCUPIED BY STREET VENDORS (OFFFIELD)
 ■ ROW AREAS OCCUPIED BY TAXI/AUTHORIZED STREET VENDORS OR EQUIVALENT
 ■ DAKADALA STOPS
 ■ DAKADALA PARKING AREAS
 ■ TAXI SPOTS
 ■ TRUCK PARKING AREAS
 ■ OTHER PARKING AREAS (INDICATE USE)
 ● OTHER (INDICATE USE)

located by:
 Surveyed by: Juliana C. Antunes
 Designed by:
 Drawn by: Fabrizia Oliveri
 Checked by:
 Approved by:
 Scale: 1:2500

Project:
DAR RAPID TRANSIT (DART)
 Subject:
**LAND USE IDENTIFICATION
 DIRECT AFFECTED AREA - DAA**
 Date: January 2007
 Drg No. T301-CE-RD-LAID-04 REV 00

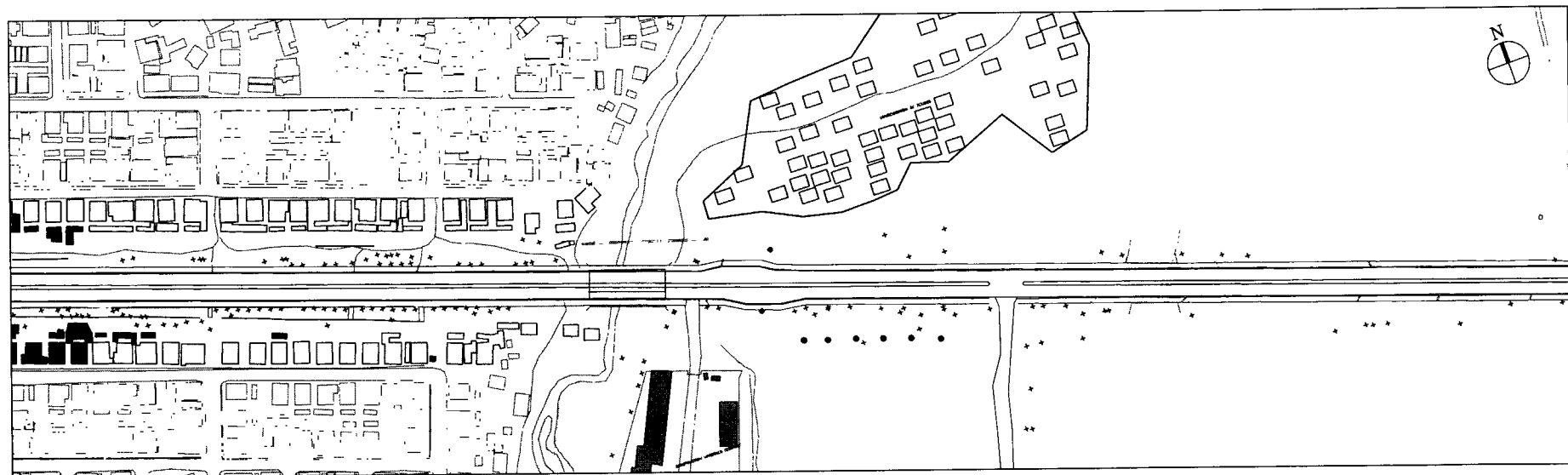

Client:
DAR ES SALAAM CITY COUNCIL
 P O Box 9084, Dar es Salaam, Tanzania
 Tel: + 255-22-2123551/6
 Email: cd@dcc.go.tz

Consultant:
LOGIT Logit Engenharia Consultiva Ltda
 Av. Lúcio Martins 880, 8.º Andar
 CEP 05422-000, São Paulo, Brazil
 In consultation with:
inter-consult ltd
 P O Box 453, Dar es Salaam, Tanzania
 Tel: + 255-22-2772424/2772477
 Email: info@interconsult-tz.com
 ZQP Consultores e Partidários Lda.
 Rua Américo Bragança, 515
 CEP 04715-003, São Paulo, Brazil
 Email: info@consultoria.com.br

LEGEND:
 * TREES
 ▲ ABUTTING PROPERTIES:
 ■ RESIDENTIAL PROPERTIES (at ground floor)
 ■ COMMERCIAL ACTIVITY TYPES:
 ■ RESTAURANT/BAFÉ/FOOD & LEISURE/HOTEL
 ■ VEHICLE RELATED SERVICES (EXCLUDING PETROL STATIONS)
 ■ PETROL STATIONS
 ■ OTHER RETAIL OR SERVICES (INCLUDING BANKS AND FINANCIAL INSTITUTIONS AND MARKETS)
 ■ RELIGIOUS BUILDINGS
 ■ PUBLIC/INSTITUTIONAL BUILDINGS (INCLUDING SCHOOLS)
 ■ INDUSTRIAL
 ■ OTHER (HOSPITALS, FIRE STATION, ETC)

CLASSIFICATION BY HEIGHT:
 ■ 1 OR 2 STOREY BUILDINGS
 ■ 3 OR 4 STOREY BUILDINGS
 ■ 5 OR MORE STOREY BUILDINGS
 ■ UPPER STOREY PREDOMINANT USE:
 ■ RESIDENTIAL
 ■ COMMERCIAL

USES INSIDE THE RIGHT-OF-WAY (ROW)
 ■ AREA OCCUPIED BY BARS AND RESTAURANTS
 ■ OTHER ROW AREAS OCCUPIED BY ABUTTING COMMERCE
 ■ ROW AREAS OCCUPIED BY STREET VENDORS (PORTABLE VENDORS OR EQUIVALENT)
 ● DALADALA STOPS
 ● DALADALA PARKING AREAS
 ● TAXI SPOTS
 ● TRUCK PARKING AREAS
 ● OTHER PARKING AREAS (INDICATE USE)
 * OTHER (INDICATE USE)

located by:
 Surveyed by: Juliana C. Antunes
 Designed by: Fabrizia Olivari
 Checked by:
 Approved by:
 Scale: 1:250

Project: **DAR RAPID TRANSIT (DART)**
 Subject: **LAND USE IDENTIFICATION
 DIRECT AFFECTED AREA - DAA**
 Date: January 2007
 Drg No. T301-CE-RD-LAID-05 REV 00

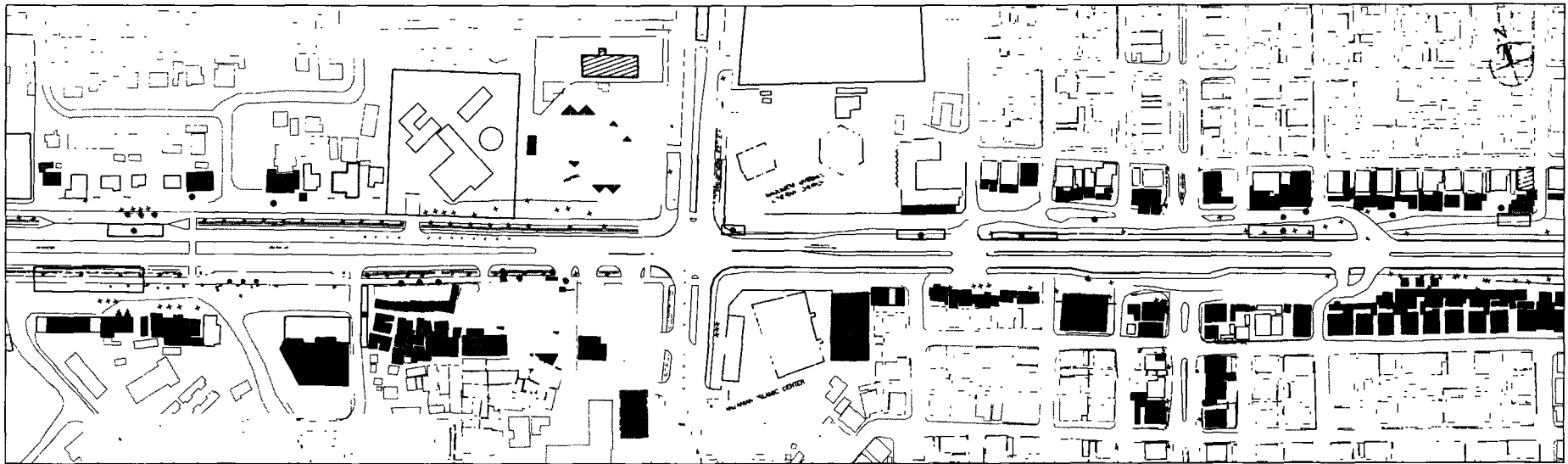
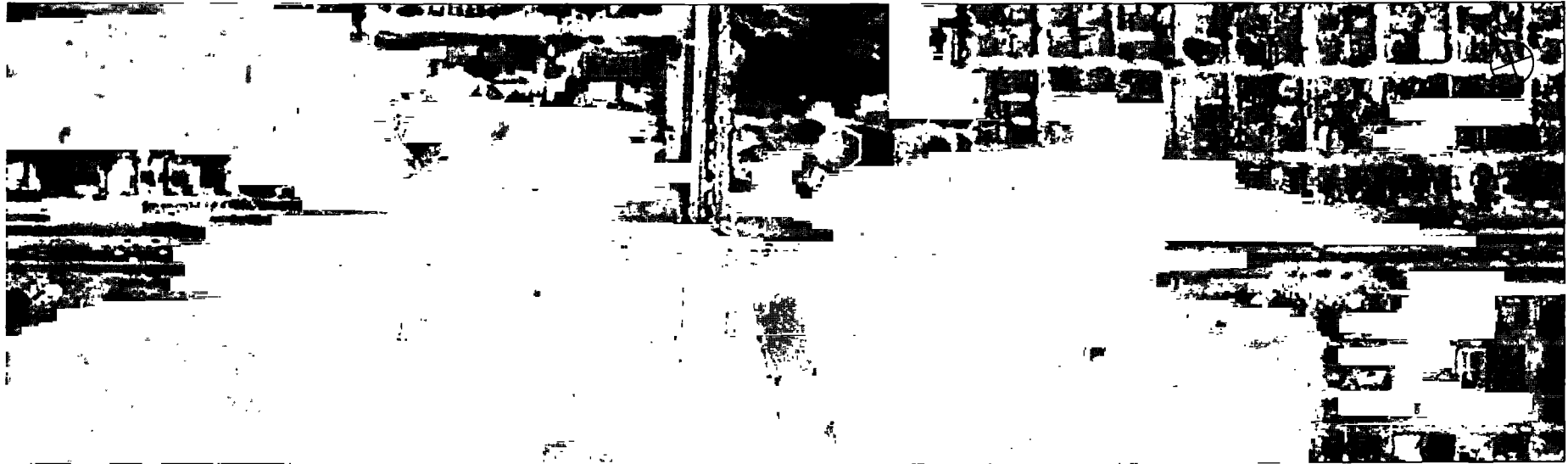

<p>Client:</p>  <p>DAR ES SALAAM CITY COUNCIL P O Box 9084, Dar es Salaam, Tanzania Tel: + 255-22-2123551/6 Email: cd@dcc.go.tz</p>	<p>Consultant:</p> <p>LOGIT Logit Engenharia Consultiva Ltda Av. Curitiba 36000, 615 - Andar CEP 04713-003, São Paulo, Brazil In association with</p> <p>inter-consult ltd P. O. Box 423, Dar es Salaam, Tanzania Tel: + 255-22-2772424/2772477 Email: info@interconsult.co.tz</p> <p>ADP Consultoria e Participações Ltda. Rua Antônio Brás, 615 CEP 04713-003, São Paulo, Brazil Email: info@adpconsultoria.com.br</p>	<p>LEGEND</p> <p>• TREES</p> <p>ABUTTING PROPERTIES:</p> <p>RESIDENTIAL PROPERTIES (at ground floor)</p> <p>CONSTRUCTION ACTIVITY TYPES:</p> <p>RESTAURANT/BAR/FOOD & LEISURE/HOTEL</p> <p>VEHICLE RELATED SERVICES (EXCLUDING PETROL STATIONS)</p> <p>PETROL STATIONS</p> <p>OTHER RETAIL OR SERVICES (INCLUDING BANKS AND FINANCIAL INSTITUTIONS AND MARKETS)</p> <p>RELIGIOUS BUILDINGS</p> <p>PUBLIC/INSTITUTIONAL BUILDINGS (INCLUDING SCHOOLS)</p> <p>INDUSTRIAL</p> <p>OTHER (HOSPITALS, FIRE STATION, ETC)</p>	<p>CLASSIFICATION BY HEIGHT:</p> <p>1 OR 2 STOREY BUILDINGS</p> <p>3 OR 4 STOREY BUILDINGS</p> <p>5 OR MORE STOREY BUILDINGS</p> <p>UPPER STOREY PREDOMINANT USE:</p> <p>RESIDENTIAL</p> <p>COMMERCIAL</p>	<p>USES INSIDE THE RIGHT-OF-WAY (ROW)</p> <p>AREA OCCUPIED BY BARS AND RESTAURANTS</p> <p>OTHER ROW AREAS OCCUPIED BY AUTHORIZED COMMERCE</p> <p>ROW AREAS OCCUPIED BY STREET VENDORS (PORTABLE)</p> <p>ROW AREAS OCCUPIED BY FIXED/AUTHORIZED STREET VENDORS OR EQUIPMENT</p> <p>DALADALA STOPS</p> <p>DALADALA PARKING AREAS</p> <p>TAXI SPOTS</p> <p>TRUCK PARKING AREAS</p> <p>OTHER PARKING AREAS (INDICATE USE)</p> <p>OTHER (INDICATE USE)</p>	<p>located by:</p> <p>Surveyed by: Juliana C. Antunes</p>	<p>Project:</p> <p>DAR RAPID TRANSIT (DART)</p>
					<p>Designed by:</p> <p>Drawn by: Fabrizia Oliverii</p>	<p>Subject:</p> <p>LAND USE IDENTIFICATION DIRECT AFFECTED AREA - DAA</p>
					<p>Checked by:</p>	<p>Date:</p> <p>January 2007</p>
					<p>Approved by:</p>	<p>Scale:</p> <p>1:500</p>
					<p>Scale:</p> <p>1:500</p>	<p>Org No. T301-CE-RD-LAD-06</p> <p>REV 00</p>

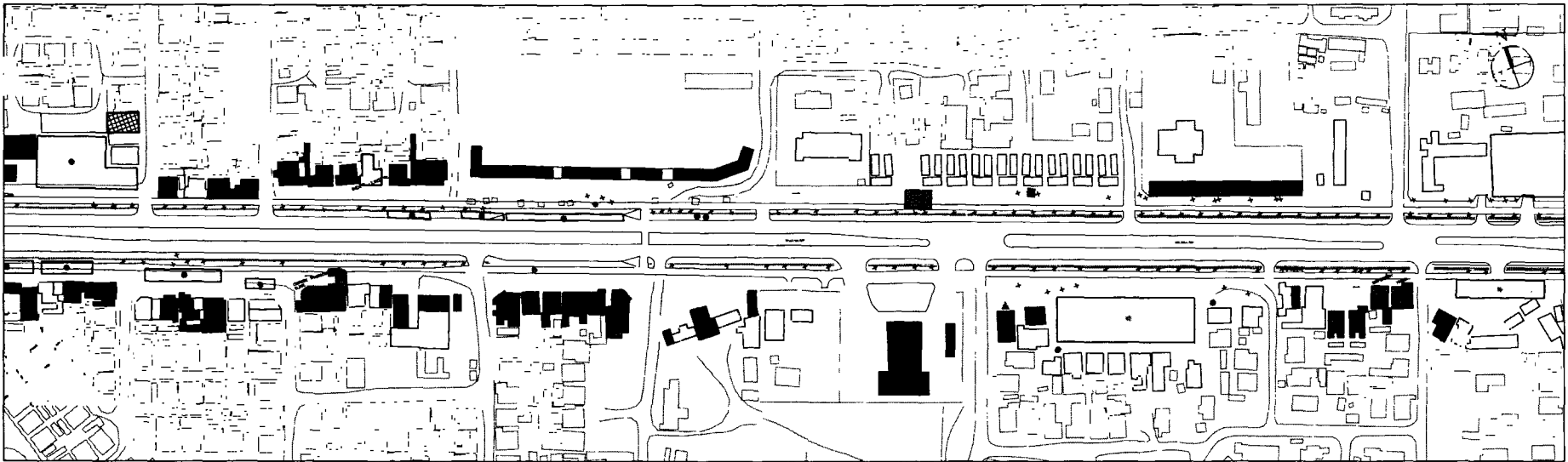

Client:

DAR ES SALAAM CITY COUNCIL
 P O Box 9084, Dar es Salaam, Tanzania
 Tel: + 255-22-2123551/6
 Email: cd@dcc.go.tz

Consultant:
LOGIT Logit Engenharia Consultiva Ltda
 Av. Paulista, Sétimo 890, 8 - Jd. Jardenas
 CEP: 05423-000, São Paulo, Brazil
 In association with

inter-consult ltd
 P O Box 423, Dar es Salaam, Tanzania
 Tel: + 255-22-2778424/2778427
 Email: zulu@interconsult-td.com
 ZSP Consultoria e Participações Ltda.
 Rua Antônio Brilhante, 615
 CEP: 04113-003, São Paulo, Brazil
 Email: log@zspconsultoria.com.br

LEGEND:

• THESE

ADJUTING PROPERTIES:

- RESIDENTIAL PROPERTIES (at ground floor)
- COMMERCIAL ACTIVITY TYPES:
- RESTAURANT/BAR/FOOD & LEISURE/HOTEL
- VEHICLE RELATED SERVICES (EXCLUDING PETROL STATIONS)
- PETROL STATIONS
- OTHER RETAIL OR SERVICES (INCLUDING BANKS AND FINANCIAL INSTITUTIONS AND MARKETS)
- OFFICES
- RECREATION & LEISURE (INCLUDING SCHOOLS)
- OTHER (HOSPITALS, FIRE STATION, ETC)

CLASSIFICATION BY HEIGHT:

- 1 OR 2 STOREY BUILDINGS
- 3 OR 4 STOREY BUILDINGS
- 5 OR MORE STOREY BUILDINGS
- UPPER STOREY PREDOMINANT USE:
- RESIDENTIAL
- COMMERCIAL

USES INSIDE THE RIGHT-OF-WAY (ROW)

- AREA OCCUPIED BY BARS AND RESTAURANTS
- OTHER ROW AREAS OCCUPIED BY HABITING COMMERCE
- ROW AREAS OCCUPIED BY STREET VENDORS (PORTABLE)
- ROW AREAS OCCUPIED BY FIXED/AUTHORIZED STREET VENDORS OR EQUIVALENT
- DAKADALA STOPS
- TRUCK PARKING AREAS
- TAXI SPOTS
- OTHER PARKING AREAS (INDICATE USE)
- OTHER (INDICATE USE)

located by:	Project:
Surveyed by: Juliana C. Antunes	DAR RAPID TRANSIT (DART)
Designed by:	Subject:
Drawn by: Fabricia Oliverii	LAND USE IDENTIFICATION
Checked by:	DIRECT AFFECTED AREA - DMA
Approved by:	Date: January 2007
Scale: 1:250	Org No. T301-CE-RD-LAID-07
	REV 00



Client:

DAR ES SALAAM CITY COUNCIL
 P O Box 9084, Dar es Salaam, Tanzania
 Tel: + 255-22-2123551/6
 Email: cd@dcc.go.tz

Consultant:
LOGIT
 Logit Engenharia Consultiva Ltda
 Av. Lusitânia, 880, 6.º Andar
 CEP 04045-000, São Paulo, Brasil
 In association with
inter-consult ltd
 P O Box 423, Dar es Salaam, Tanzania
 Tel: + 255-22-2772484/2772477
 Email: info@interconsult.co.tz

LEGEND:
 - TREES
ABUTTING PROPERTIES:
 ■ RESIDENTIAL PROPERTIES (at ground floor)
COMMERCIAL ACTIVITY TYPES:
 ■ RESTAURANT/BAR/FOOD & LEISURE/HOTEL
 ■ VEHICLE RELATED SERVICES (EXCLUDING PETROL STATIONS)
 ■ PETROL STATIONS
 ■ OTHER RETAIL OR SERVICES (INCLUDING BANKS AND FINANCIAL INSTITUTIONS AND MARKETS)
 ■ RELIGIOUS BUILDINGS
 ■ PUBLIC/INSTITUTIONAL BUILDINGS (INCLUDING SCHOOLS)
 ■ INDUSTRIAL
 ■ OTHER (HOSPITALS, FIRE STATION, ETC)

CLASSIFICATION BY HEIGHT:
 ■ 1 OR 2 STOREY BUILDINGS
 ■ 3 OR 4 STOREY BUILDINGS
 ■ 5 OR MORE STOREY BUILDINGS
STREET PREDOMINANT USE:
 ■ RESIDENTIAL
 ■ COMMERCIAL
USES INSIDE THE RIGHT-OF-WAY (ROW)
 ▲ AREA OCCUPIED BY BARS AND RESTAURANTS
 ● OTHER ROW AREAS OCCUPIED BY ABUTTING COMMERCE
 ● ROW AREAS OCCUPIED BY STREET VENDORS (PORTABLES)
 ● ROW AREAS OCCUPIED BY TAXIS/AUTHORIZED STREET VENDORS OR EQUIVALENT
 ● DALADLA STOPS
 ● DALADLA PARKING AREAS
 ● TAXI SPOTS
 ● TRUCK PARKING AREAS
 ● OTHER PARKING AREAS (INDICATE USE)
 ● OTHER (INDICATE USE)

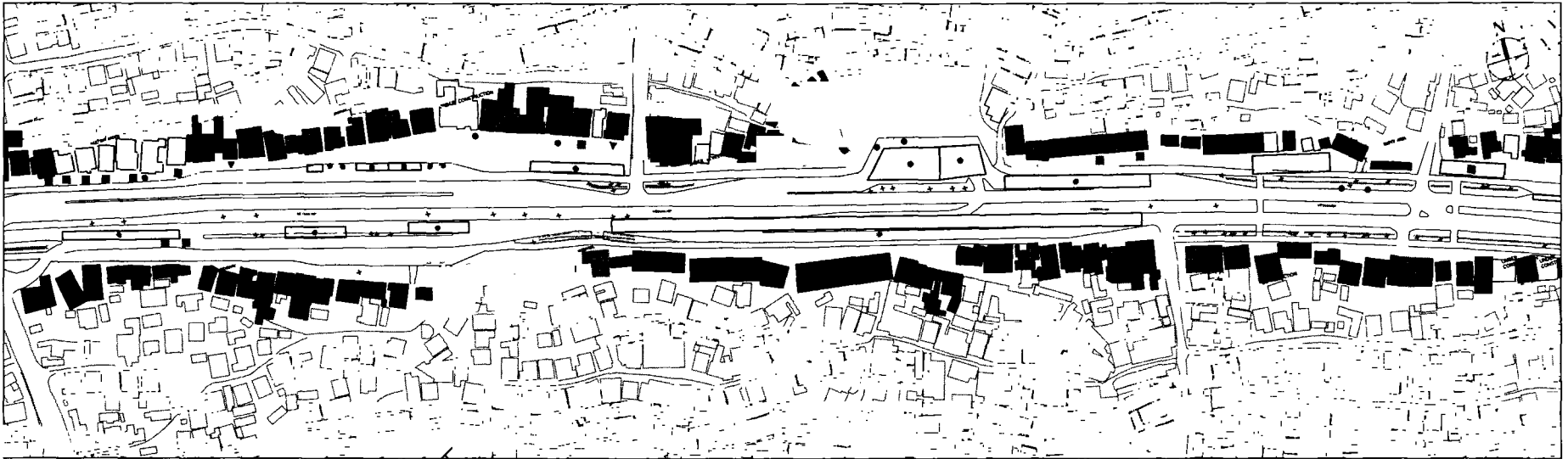
located by:	Project:
Surveyed by: Juliana C. Antunes	DAR RAPID TRANSIT (DART)
Designed by:	Subject:
Drawn by: Fabrizia Oliverii	LAND USE IDENTIFICATION
Checked by:	DIRECT AFFECTED AREA - DAA
Approved by:	Date: January 2007
Scale: 1:500	Drq No. T301-CE-RD-LAID-08
	REV 00



Client:



DAR ES SALAAM CITY COUNCIL
 P O Box 9084, Dar es Salaam, Tanzania
 Tel: + 255-22-2123551/6
 Email: cd@dcc.go.tz

Consultant:

LOGIT Logit Engenharia Consultiva Ltda
 Av. Lacerda Soares 890, 8 - Jd. Jd. Jd.
 CEP 05423-000, São Paulo, Brazil
 In association with
inter-consult Ltd
 P O Box 423, Dar es Salaam, Tanzania
 Tel: + 255-22-2772424/2772477
 Email: info@interconsult-tz.com
 JOP Consultoria e Participações Ltda.
 Rua Andréa Broedel, 615
 CEP 04713-003, São Paulo, Brazil
 Email: jop@jopconsultoria.com.br

LEGEND:

• TREES
 * ADJUTING PROPERTIES:
 RESIDENTIAL PROPERTIES (at ground floor)
 COMMERCIAL ACTIVITY TYPES:
 RESTAURANT/BAR/FOOD & LEISURE/HOTEL
 VEHICLE RELATED SERVICES (EXCLUDING PETROL STATIONS)
 PETROL STATIONS
 OTHER RETAIL OR SERVICES (INCLUDING BANKS AND FINANCIAL INSTITUTIONS AND MARKETS)
 SCHOOLS
 INDUSTRIAL
 OTHER (HOSPITALS, FIRE STATION, ETC)

CLASSIFICATION BY HEIGHT:
 1 OR 2 STOREY BUILDINGS
 3 OR 4 STOREY BUILDINGS
 5 OR MORE STOREY BUILDINGS
 UPPER STOREY PREDOMINANT USE:
 RESIDENTIAL
 COMMERCIAL

USES INSIDE THE RIGHT-OF-WAY (ROW)
 AREA OCCUPIED BY BARS AND RESTAURANTS
 OTHER ROW AREAS OCCUPIED BY ALIENATED COMMERCIAL VEHICLES OR EQUIVALENT
 ROW AREAS OCCUPIED BY FIXED/AUTHORIZED STREET VENDORS OR EQUIVALENT
 DALADALA STOPS
 TAXI STOPS
 TRUCK PARKING AREAS
 OTHER PARKING AREAS (INDICATE USE)
 OTHER (INDICATE USE)

located by:	Project:
Surveyed by: Juliana C. Antunes	DAR RAPID TRANSIT (DART)
Designed:	Subject:
Drawn by: Fabrizia Oliveira	LAND USE IDENTIFICATION DIRECT AFFECTED AREA - DAA
Checked by:	Date: January 2007
Approved by:	Drng No. T301-CE-RD-LAID-09
Scale: 1:7500	REV 00

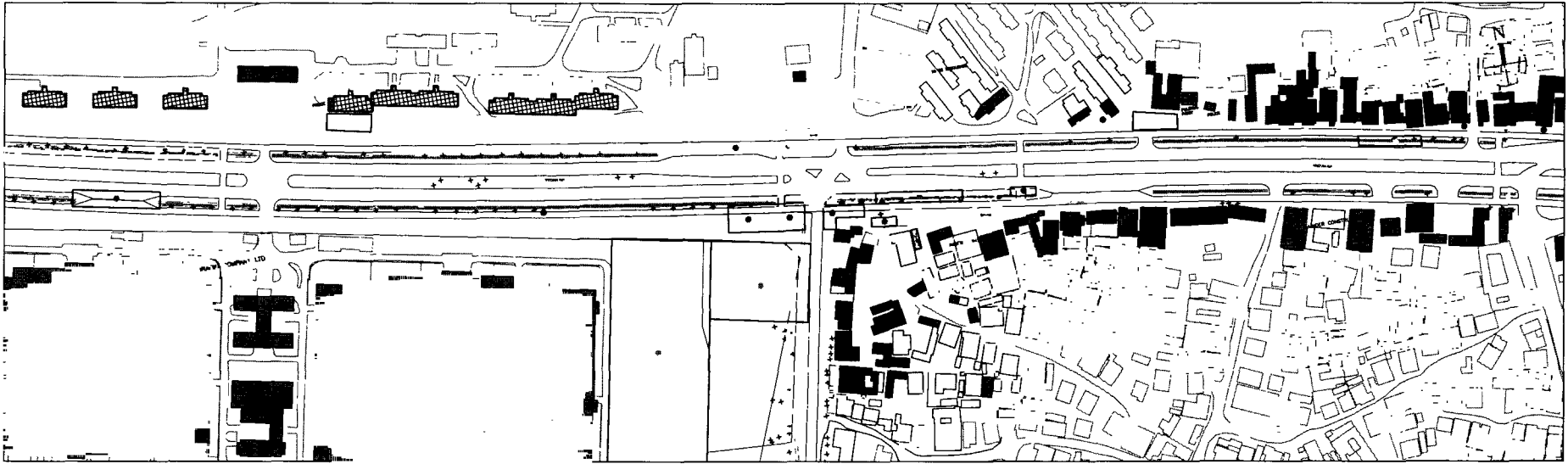
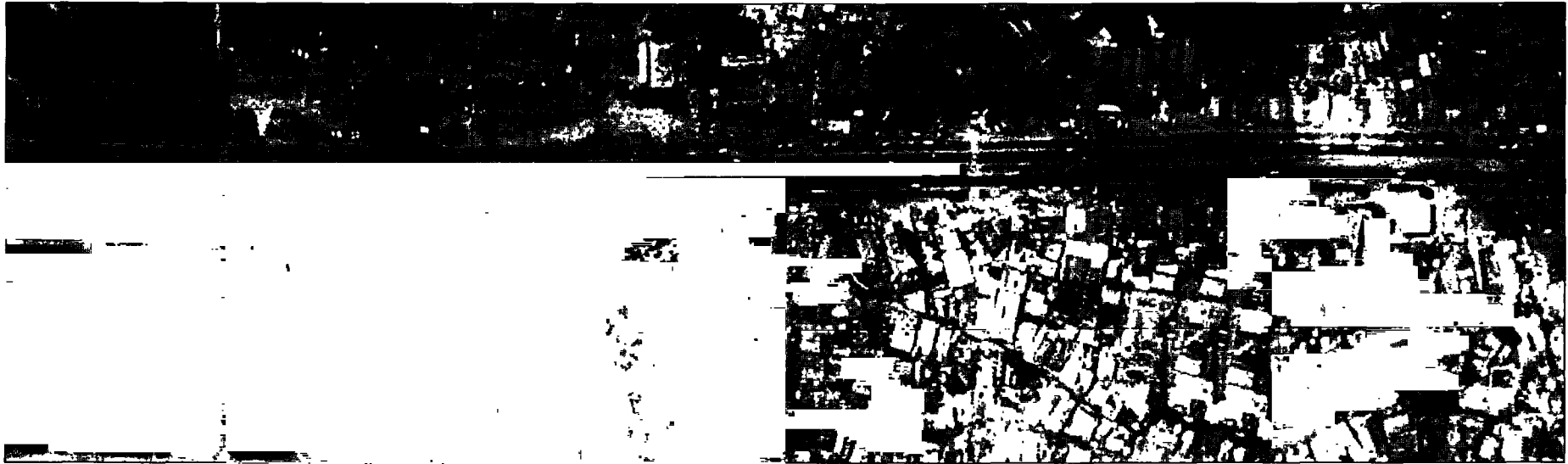

Client:

DAR ES SALAAM CITY COUNCIL
 P O Box 9084, Dar es Salaam, Tanzania
 Tel: + 255-22-2123551/6
 Email: cd@dcc.go.tz

Consultant:
LOGIT
 Logit Engenharia Consultiva Ltda
 Av. Euclides da Cunha 880, 8 - Andar
 CEP 05453-000, São Paulo, Brasil
 In cooperation with
inter-consult ltd
 P O Box 623, Dar es Salaam, Tanzania
 Tel: + 255-22-2772434/2772477
 Email: info@interconsult.co.tz

LEGEND:
 + TREES
 ABUTTING PROPERTIES:
 RESIDENTIAL PROPERTIES (at ground floor)
 COMMERCIAL ACTIVITY TYPES:
 RESTAURANT/BAR/FOOD & LEISURE/HOTEL
 VEHICLE RELATED SERVICES (EXCLUDING PETROL STATIONS)
 PETROL STATIONS
 OTHER RETAIL OR SERVICES (INCLUDING BANKS AND FINANCIAL INSTITUTIONS AND MARKETS)
 RELIGIOUS BUILDINGS
 PUBLIC/INSTITUTIONAL BUILDINGS (INCLUDING SCHOOLS)
 INDUSTRIAL
 OTHER (HOSPITALS, FIRE STATION, ETC)

CLASSIFICATION BY HEIGHT:
 1 OR 2 STOREY BUILDINGS
 3 OR 4 STOREY BUILDINGS
 5 OR MORE STOREY BUILDINGS
 UPPER STOREY PRODOMINANT USE:
 RESIDENTIAL
 COMMERCIAL

USES INSIDE THE RIGHT-OF-WAY (ROW)
 AREA OCCUPIED BY BARS AND RESTAURANTS
 OTHER ROW AREAS OCCUPIED BY ABUTTING COMMERCE
 ROW AREAS OCCUPIED BY STREET VENDORS (POPFIELDS)
 ROW AREAS OCCUPIED BY FIKES/AUTHORIZED STREET VENDORS OR EQUIVALENT
 DAKADLA STOPS
 DAKADLA PARKING AREAS
 TAXI SPOTS
 TRUCK PARKING AREAS
 OTHER PARKING AREAS (INDICATE USE)
 OTHER (INDICATE USE)

located by:	Project:
Surveyed by: Juliana C Antunes	DAR RAPID TRANSIT (DART)
Designed by:	Subject:
Drawn by: Fabrizia Olivieri	LAND USE IDENTIFICATION
Checked by:	DIRECT AFFECTED AREA - DAA
Approved by:	Date: January 2007
Scale: 1:250	Org No: TJ01-CE-RD-LAID-10
	REV 00

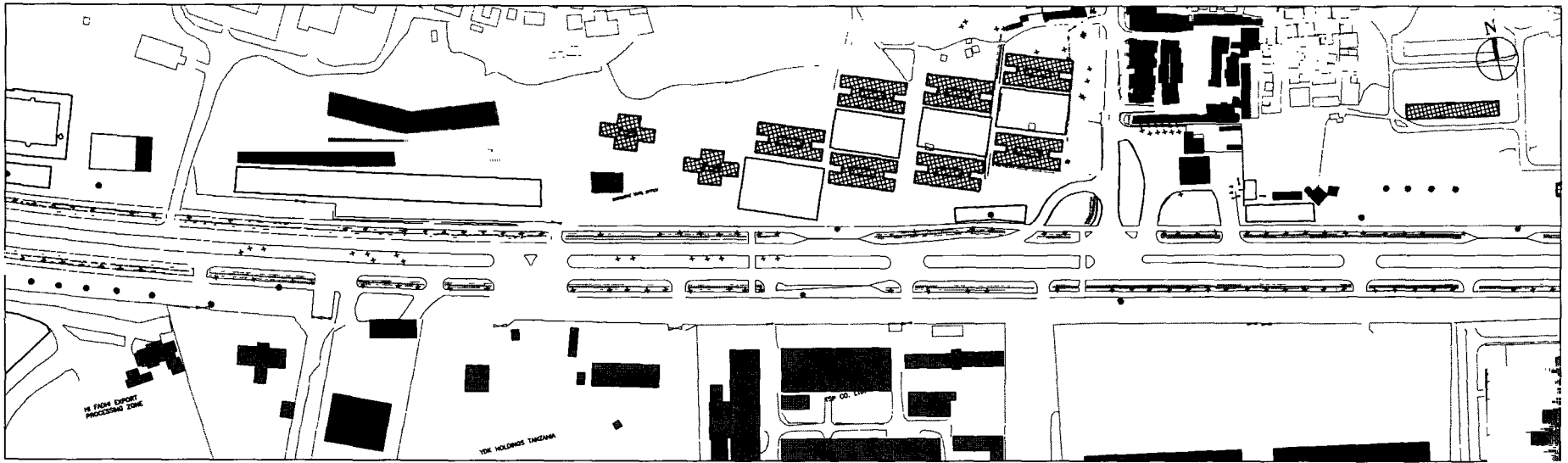
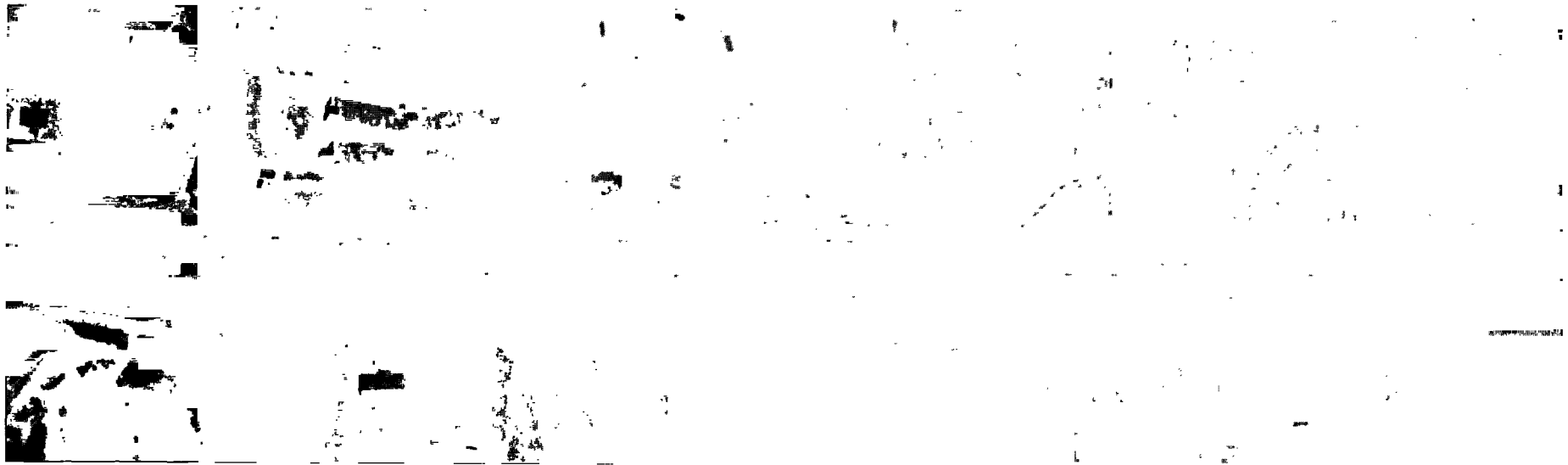

Client:

 **DAR ES SALAAM CITY COUNCIL**
 P O Box 9084, Dar es Salaam, Tanzania
 Tel: + 255-22-2123551/6
 Email: cd@dcc.go.tz

Consultant:

LOGIT
 Logit Engenharia Consultiva Ltda
 Av. Lusitânia S/Nº 680, 6.º Andar
 CEP 05423-000, São Paulo, Brasil
 In association with
inter-consult ltd
 P O Box 423, Dar es Salaam, Tanzania
 Tel: + 255-22-2772424/2772477
 Email: info@interconsult-tz.com





LEGEND:

Trees

ABUTTING PROPERTIES:

- RESIDENTIAL PROPERTIES (at ground floor)
- COMMERCIAL ACTIVITY TYPES
- RESTAURANT/BAR/FOOD & LEISURE/HOTEL
- VEHICLE RELATED SERVICES (EXCLUDING PETROL STATIONS)
- PETROL STATIONS
- OTHER RETAIL OR SERVICES (INCLUDING BANKS AND FINANCIAL INSTITUTIONS AND MARKETS)
- RELIGIOUS BUILDINGS
- PUBLIC/INSTITUTIONAL BUILDINGS (INCLUDING SCHOOLS)
- INDUSTRIAL
- OTHER (HOSPITALS, FIRE STATION, ETC)

CLASSIFICATION BY HEIGHT:

- 1 OR 2 STOREY BUILDINGS
- 3 OR 4 STOREY BUILDINGS
- 5 OR MORE STOREY BUILDINGS

UPPER STOREY PREDOMINANT USE:

- RESIDENTIAL
- COMMERCIAL

USES INSIDE THE RIGHT-OF-WAY (ROW)

- AREA OCCUPIED BY BARS AND RESTAURANTS
- OTHER ROW AREAS OCCUPIED BY ABUTTING COMMERCIAL
- ROW AREAS OCCUPIED BY STREET VENDORS (PORTABLE VENDORS OR EQUIVALENT)
- DAKADALA STEPS
- DAKADALA PARKING AREAS
- TAXI SPOTS
- TRUCK PARKING AREAS
- OTHER PARKING AREAS (INDICATE USE)
- OTHER (INDICATE USE)

located by:

Surveyed by: Juliana C. Antunes

Designed by: Fabrizia Oliverii

Checked by:

Approved by:

Scale: 1:2500

Project: **DAR RAPID TRANSIT (DART)**

Subject: **LAND USE IDENTIFICATION
DIRECT AFFECTED AREA - DMA**

Date: **January 2007**

Drg No: **T301-CE-RD-LAID-11** REV 00

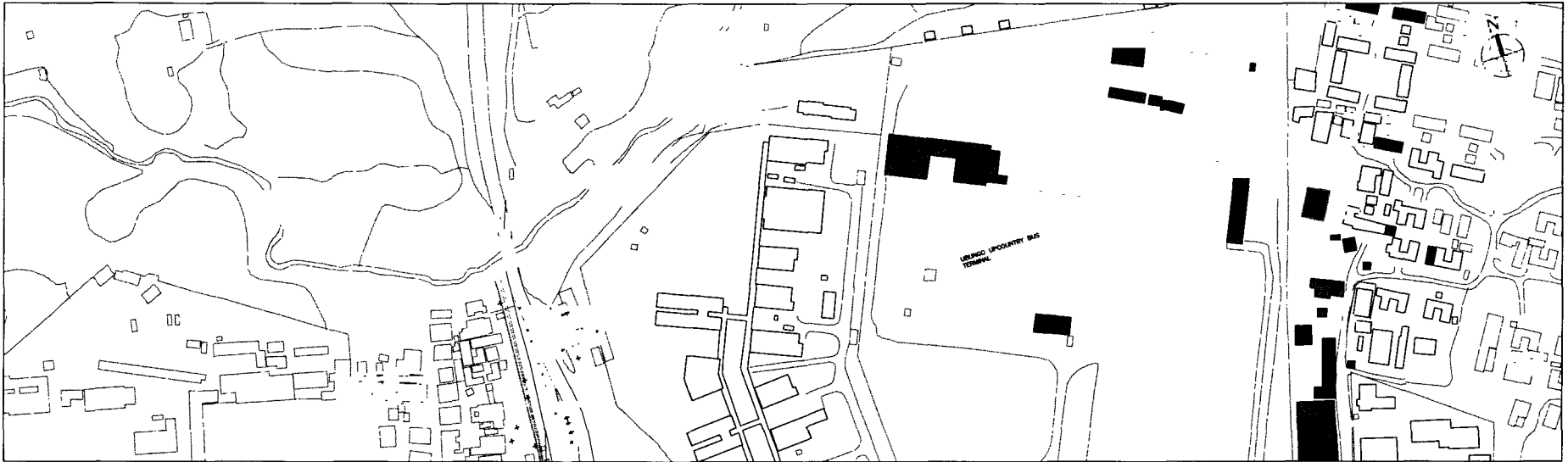

Client:



DAR ES SALAAM CITY COUNCIL
 P O Box 9084, Dar es Salaam, Tanzania
 Tel: + 255-22-2123551/6
 Email: cd@dcc.go.tz

Consultant:



LOGIT Engenharia Consultiva Ltda
 Av. Esplanada, Botafogo, Rio de Janeiro
 CEP 22251-000, São Paulo, Brazil



inter-consult ltd
 P O Box 423, Dar es Salaam, Tanzania
 Tel: + 255-22-2772424/2772477
 Email: info@interconsult-tz.com



Participações e Empreendimentos S.A.
 Rua Arvidsson, Botafogo, Rio de Janeiro
 CEP 22251-000, São Paulo, Brazil
 Email: info@participacoes.com.br

LEGEND:

- TREES
- ▲ ABUTTING PROPERTIES:
- ▭ RESIDENTIAL PROPERTIES (at ground floor)
- ▭ COMMERCIAL ACTIVITY TYPES
- ▭ RESTAURANT/FOOD & LEISURE/HOTEL
- ▭ VEHICLE RELATED SERVICES (EXCLUDING PETROL STATIONS)
- ▭ PETROL STATIONS
- ▭ OTHER RETAIL OR SERVICES (INCLUDING BANKS AND FINANCIAL INSTITUTIONS AND MARKETS)
- ▭ RELIGIOUS BUILDINGS
- ▭ PUBLIC/INSTITUTIONAL BUILDINGS (INCLUDING SCHOOLS)
- ▭ INDUSTRIAL
- ▭ OTHER (HOSPITALS, FIRE STATION, ETC)

CLASSIFICATION BY HEIGHT:

- ▭ 1 OR 2 STOREY BUILDINGS
- ▭ 3 OR 4 STOREY BUILDINGS
- ▭ 5 OR MORE STOREY BUILDINGS
- ▭ UPPER STOREY PREDOMINANT USE:
- ▭ RESIDENTIAL
- ▭ COMMERCIAL

USES INSIDE THE RIGHT-OF-WAY (ROW)

- ▲ AREA OCCUPIED BY BARS AND RESTAURANTS
- ▲ OTHER ROW AREAS OCCUPIED BY ABUTTING COMMERCE
- ▲ ROW AREAS OCCUPIED BY STREET VENDORS (PORTABLE)
- ▲ ROW AREAS OCCUPIED BY KIOSK/AUTHORIZED STREET VENDORS OR EQUIPMENT
- DAIRY/DAIRA STEPS
- DAIRY/DAIRA PARKING AREAS
- TAXI SPOTS
- TRUCK PARKING AREAS
- OTHER PARKING AREAS (INDICATE USE)
- OTHER (INDICATE USE)

located by	Project:
Surveyed by: Juliana C. Antunes	DAR RAPID TRANSIT (DART)
Designed:	Subject:
Drawn by: Fabrizia Oliverii	LAND USE IDENTIFICATION
Checked by:	DIRECT AFFECTED AREA - DAA
Approved by:	Date: January 2007
Scale: 1:200	Org No. T301-CE-RD-LA10-12
	REV 00

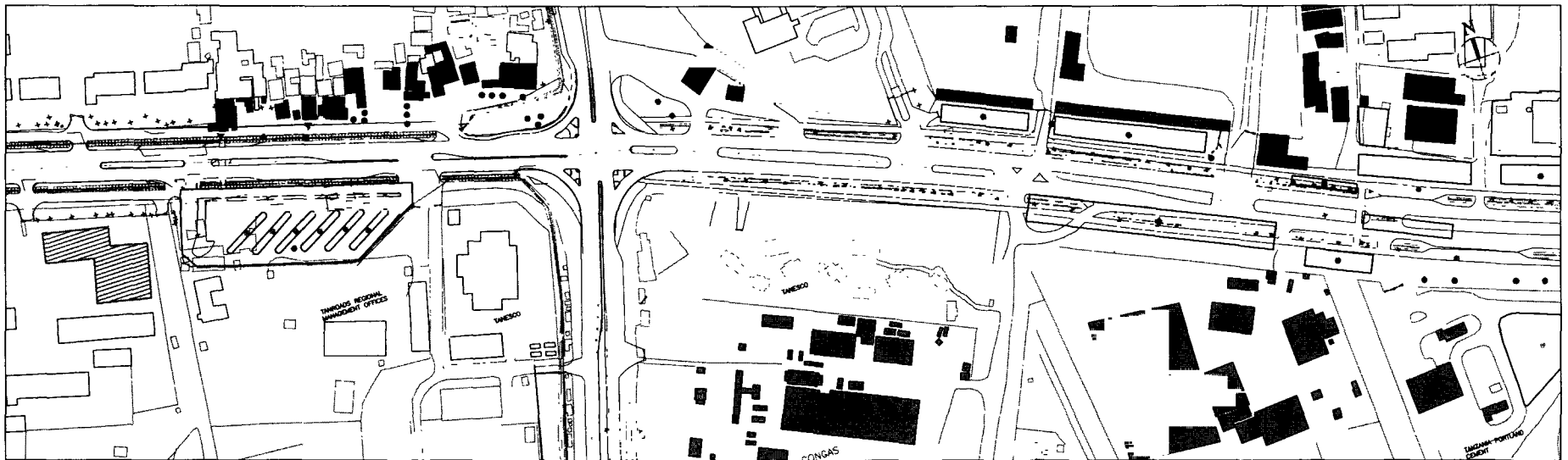

Client:



DAR ES SALAAM CITY COUNCIL
 P O Box 9084, Dar es Salaam, Tanzania
 Tel: + 255-22-2123551/6
 Email: cd@dcc.go.tz

Consultant:

LOGIT Logit Engenharia Consultiva Ltda
 Av. Esmeralda, Edifício 800, 8 - F. Fátima
 CEP 05423-000, São Paulo, Brazil
 in consultation with
inter-consult ltd
 P O Box 423, Dar es Salaam, Tanzania
 Tel: + 255-22-2772424/2772477
 Email: info@interconsult-tz.com
 ZEP Consultoria e Participações Ltda.
 Rua Andréa Bragança, 616
 CEP 04718-000, São Paulo, Brazil
 Email: jpb@zepconsultoria.com.br

LEGEND:

- + TREES
- ADJUTING PROPERTIES:
- RESIDENTIAL PROPERTIES (at ground floor)
- COMMERCIAL ACTIVITY TYPES:
- RESTAURANT/BAR/FOOD & LEISURE/HOTEL
- VEHICLE RELATED SERVICES (EXCLUDING PETROL STATIONS)
- RETAIL STATIONS
- OTHER RETAIL OR SERVICES (INCLUDING BANKS AND FINANCIAL INSTITUTIONS AND MARKETS)
- RELIGIOUS BUILDINGS
- PUBLIC/INSTITUTIONAL BUILDINGS (INCLUDING SCHOOLS)
- INDUSTRIAL
- OTHER (HOSPITALS, FIRE STATION, ETC)

- CLASSIFICATION BY HEIGHT:
- 1 OR 2 STOREY BUILDINGS
 - 3 OR 4 STOREY BUILDINGS
 - 5 OR MORE STOREY BUILDINGS
- UPPER STOREY PREDOMINANT USE:
- RESIDENTIAL
 - COMMERCIAL

- USES INSIDE THE RIGHT-OF-WAY (ROW)
- AREA OCCUPIED BY BARS AND RESTAURANTS
 - OTHER ROW AREAS OCCUPIED BY ADJUTING COMMERCE
 - ROW AREAS OCCUPIED BY STREET VENDORS (PORTABLE VENDORS OR EQUIVALENT)
 - DALADALA STOPS
 - DALADALA PARKING AREAS
 - TAXI STOPS
 - TRUCK PARKING AREAS
 - OTHER PARKING AREAS (INDICATE USE)
 - OTHER (INDICATE USE)

located by:	Project:
Surveyed by: Juliana C. Antunes	DAR RAPID TRANSIT (DART)
Designed:	Subject:
Drawn by: Fabrizia Oliverii	LAND USE IDENTIFICATION
Checked by:	DIRECT AFFECTED AREA - DAA
Approved by:	Date: January 2007
Scale: 1:2500	Drg No: T3Q1-CE-RD-LAID-13 REV 00

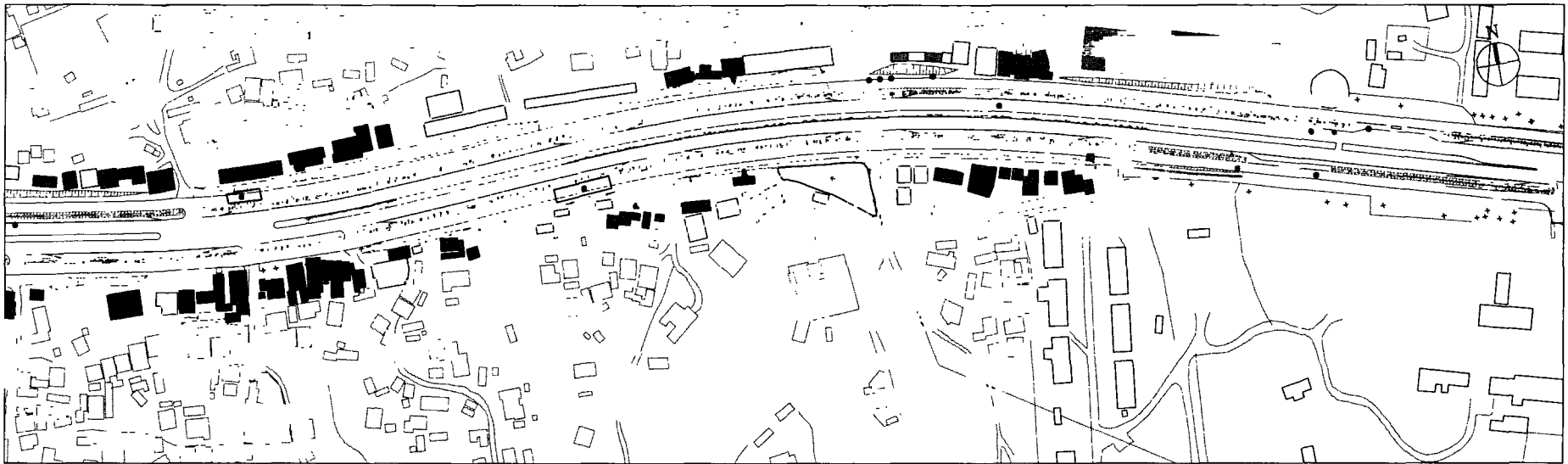
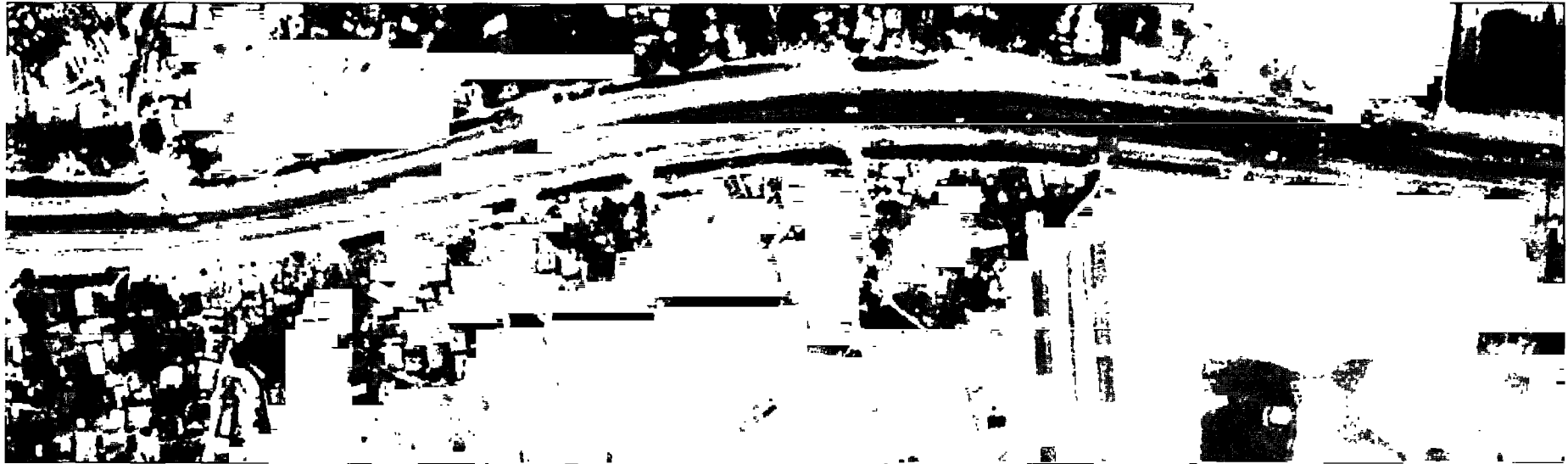

Client:

DAR ES SALAAM CITY COUNCIL
 P O Box 9084, Dar es Salaam, Tanzania
 Tel: + 255-22-2123551/6
 Email: cd@dcc.go.tz

Consultant:
LOGIT
 Logit Engenharia Consultiva Ltda
 Av. Ladeira Maluco 890, 8. Andar
 CEP 04623-000, São Paulo, Brazil
 In association with
inter-consult ltd
 P O Box 423, Dar es Salaam, Tanzania
 Tel: + 255-22-2772424/2772477
 Email: info@interconsult.com

LEGEND:
 + TREES
 ▬ ABUTTING PROPERTIES:
 ▬ RESIDENTIAL PROPERTIES (at ground floor)
 ▬ OCCUPATION ACTIVITY TYPES:
 ▬ RESTAURANT/DINING/FOOD & LEISURE/HOTEL
 ▬ VEHICLE RELATED SERVICES (EXCLUDING PETROL STATIONS)
 ▬ PETROL STATIONS
 ▬ OTHER RETAIL OR SERVICES (INCLUDING BANKS AND FINANCIAL INSTITUTIONS AND MARKETS)
 ▬ RELIGIOUS BUILDINGS
 ▬ PUBLIC/INSTITUTIONAL BUILDINGS (INCLUDING SCHOOLS)
 ▬ INDUSTRIAL
 ▬ OTHER (HOSPITALS, FIRE STATION, ETC)

CLASSIFICATION BY HEIGHT:
 ▬ 1 OR 2 STOREY BUILDINGS
 ▬ 3 OR 4 STOREY BUILDINGS
 ▬ 5 OR MORE STOREY BUILDINGS
 ▬ UPPER STOREY PREDOMINANT USE:
 ▬ RESIDENTIAL
 ▬ COMMERCIAL

USES INSIDE THE RIGHT-OF-WAY (ROW)
 ▬ AREA OCCUPIED BY BARS AND RESTAURANTS
 ▬ OTHER ROW AREAS OCCUPIED BY ABUTTING COMMERCE
 ▬ ROW AREAS OCCUPIED BY STREET VENDORS (PORTABLE)
 ▬ ROW AREAS OCCUPIED BY FIXES/AUTHORIZED STREET VENDORS OR EQUIPMENT
 ▬ DAKADLA STOPS
 ▬ DAKADLA PARKING AREAS
 ▬ TAXI SPOTS
 ▬ TRUCK PARKING AREAS
 ▬ OTHER PARKING AREAS (INDICATE USE)
 ▬ OTHER (INDICATE USE)

located by:
 Surveyed by: Juliana C. Antunes
 Designed by:
 Drawn by: Fabrizia Oliverii
 Checked by:
 Approved by:
 Scale: 1:2500

Project:
DAR RAPID TRANSIT (DART)
 Subject:
**LAND USE IDENTIFICATION
 DIRECT AFFECTED AREA - DAA**
 Date: January 2007
 Drg No. T301-CE-RD-LAID-14 REV 00

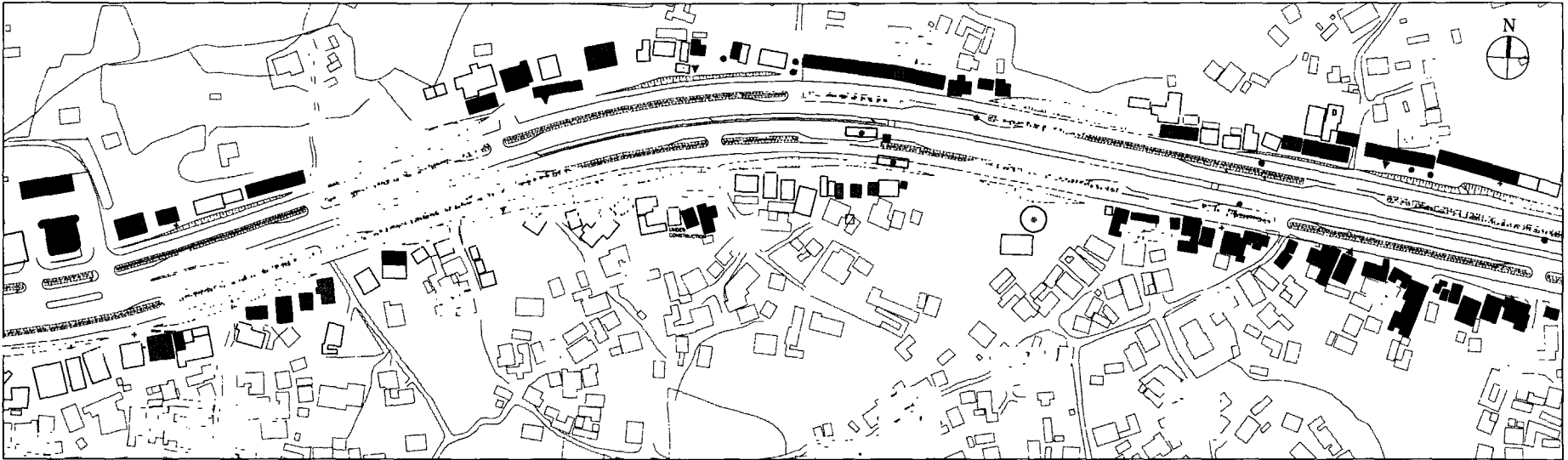
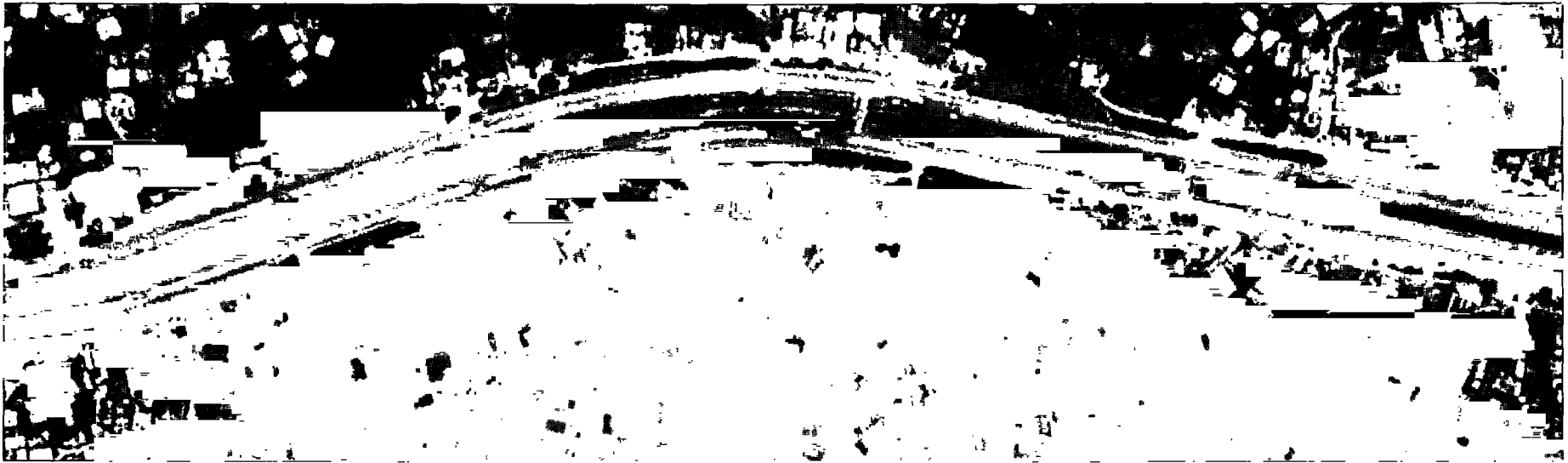

Client:

DAR ES SALAAM CITY COUNCIL
 P O Box 9084, Dar es Salaam, Tanzania
 Tel: + 255-22-2123551/6
 Email: cd@dcc.go.tz

Consultant:
LOGIT
 Logit Engenharia Consultiva Ltda
 Av. Espanha, 1600, 8. Andar
 CEP: 05453-000, São Paulo, Brazil
 In cooperation with
inter-consult ltd
 P O Box 423, Dar es Salaam, Tanzania
 Tel: + 255-22-2772424/2772477
 Email: info@interconsult.com.tz

LEGEND:
 TREES
 ABUTTING PROPERTIES:
 RESIDENTIAL PROPERTIES (at ground floor)
 COMMERCIAL ACTIVITY TYPES:
 RESTAURANT/PAV/FOOD & LEISURE/HOTEL
 OTHER RETAIL OR SERVICES (INCLUDING BANKS AND FINANCIAL INSTITUTIONS AND MARKETS)
 RELIGIOUS BUILDINGS
 PUBLIC/INSTITUTIONAL BUILDINGS (INCLUDING SCHOOLS)
 INDUSTRIAL
 OTHER (HOSPITALS, FIRE STATION, ETC)

CLASSIFICATION BY HEIGHT:
 1 OR 2 STOREY BUILDINGS
 3 OR 4 STOREY BUILDINGS
 5 OR MORE STOREY BUILDINGS
 UPPER STOREY PREDOMINANT USE:
 RESIDENTIAL
 COMMERCIAL

USES INSIDE THE RIGHT-OF-WAY (ROW)
 AREA OCCUPIED BY BARS AND RESTAURANTS
 OTHER ROW AREAS OCCUPIED BY ABUTTING COMMERCE
 ROW AREAS OCCUPIED BY STREET VENDORS (PORTABLE VENDORS OR EQUIVALENT)
 DAKADAKA STOPS
 DAKADAKA PARKING AREAS
 TAXI SPOTS
 TRUCK PARKING AREAS
 OTHER PARKING AREAS (INDICATE USE)
 OTHER (INDICATE USE)

located by:
 Surveyed by: Juliana C. Antunes
 Designed by:
 Drawn by: Fabrizia Oliveira
 Checked by:
 Approved by:
 Scale: 1:2500

Project:
DAR RAPID TRANSIT (DART)
 Subject:
**LAND USE IDENTIFICATION
 DIRECT AFFECTED AREA - DAA**
 Date: January 2007
 Drg No. T301-CE-RD-LAID-15 REV 00

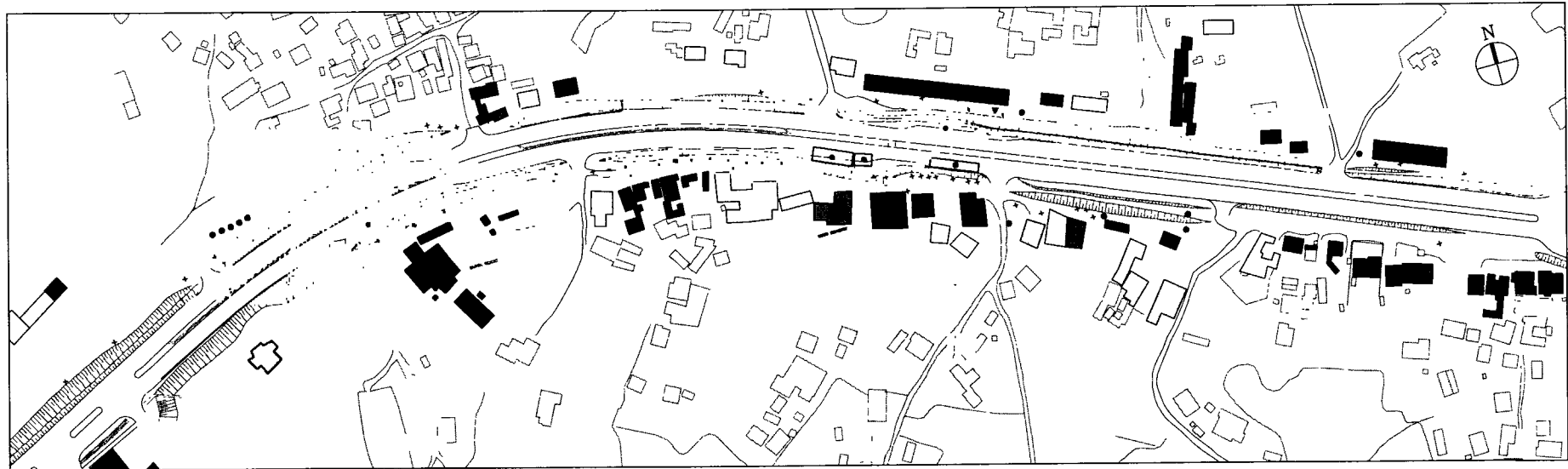

Client:
DAR ES SALAAM CITY COUNCIL
 P O Box 9084, Dar es Salaam, Tanzania
 Tel: + 255-22-2123551/6
 Email: cd@dcc.go.tz

Consultant:
LOGIT Logit Engenharia Consultiva Ltda
 Av. Espanha Mediana 880, 6 - Andar
 CEP 05423-000, Sao Paulo, Brazil
 In association with
inter-consult
 P O Box 403, Dar es Salaam, Tanzania
 Tel: + 255-22-2772424/2772477
 Email: info@interconsult-tz.com
 RUP Consultoria e Participacoes Ltda.
 Rua Andreia Brindleton, 915
 CEP 04715-003, Sao Paulo, Brazil
 Email: info@rupconsultoria.com.br

LEGEND:
 + TREES
 * ADULTING PROPERTIES:
 - RESIDENTIAL PROPERTIES (at ground floor)
COGNOMIAL ACTIVITY TYPES:
 ■ RESTAURANTS/BARS/FOOD & LEISURE/NOTEL
 ■ VEHICLE RELATED SERVICES (EXCLUDING PETROL STATIONS)
 ■ PETROL STATIONS
 ■ OTHER RETAIL OF SERVICES (INCLUDING BANKS AND FINANCIAL INSTITUTIONS AND MARKETS)
 ■ RELIGIOUS BUILDINGS
 ■ PUBLIC/INSTITUTIONAL BUILDINGS (INCLUDING SCHOOLS)
 ■ INDUSTRIAL
 ■ OTHER (HOSPITALS, FIRE STATION, ETC)

CLASSIFICATION BY HEIGHT:
 □ 1 OR 2 STOREY BUILDINGS
 □ 3 OR 4 STOREY BUILDINGS
 □ 5 OR MORE STOREY BUILDINGS
UPPER STOREY PREDOMINANT USE:
 ■ RESIDENTIAL
 ■ COMMERCIAL

USES INSIDE THE RIGHT-OF-WAY (ROW)
 ▲ AREA OCCUPIED BY BARS AND RESTAURANTS
 ■ OTHER ROW AREAS OCCUPIED BY ALIENATING COMMERCE
 ■ ROW AREAS OCCUPIED BY STREET VENDORS (PORTABLE)
 ● ROW AREAS OCCUPIED BY FIXED/AUTHORIZED STREET VENDORS OR EQUIPMENT
 ● DALADALA STOPS
 ● DALADALA PARKING AREAS
 ● TAXI SPOTS
 ● TRUCK PARKING AREAS
 ● OTHER PARKING AREAS (INDICATE USE)
 ● OTHER (INDICATE USE)

located by:
 Surveyed by: Juliano C. Antunes
 Designed by:
 Drawn by: Fabrizia Oliverii
 Checked by:
 Approved by:
 Scale: 1:200

Project:
DAR RAPID TRANSIT (DART)
 Subject:
**LAND USE IDENTIFICATION
 DIRECT AFFECTED AREA - DAA**
 Date: January 2007
 Drg No. T301-CE-RD-LAD-17 REV 00

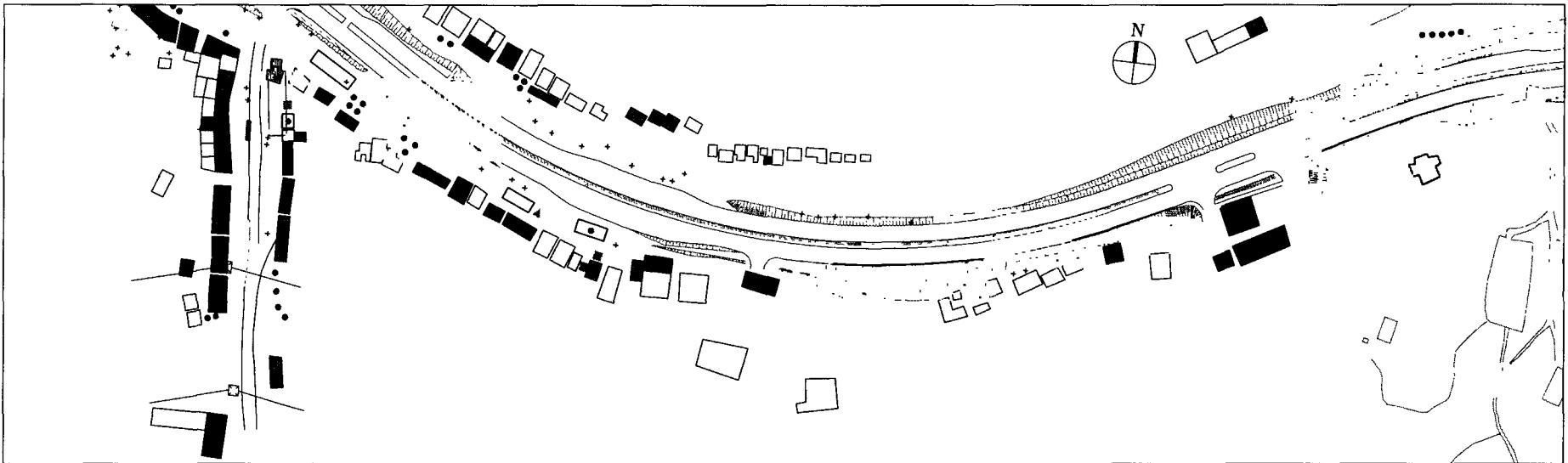
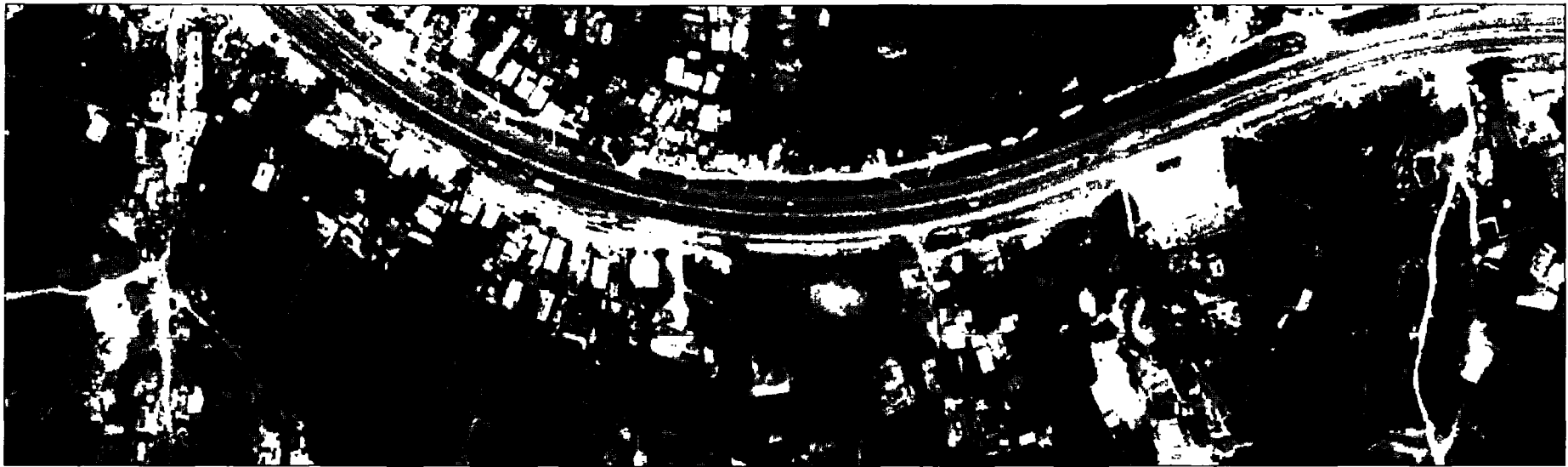

Client:

DAR ES SALAAM CITY COUNCIL
 P O Box 9084, Dar es Salaam, Tanzania
 Tel: + 255-22-2123551/6
 Email: cd@dcc.go.tz

Consultant:
LOGIT
 Logit Engenharia Consultiva Ltda
 Av. Erasmo Satone 500, 4. Andar
 CEP 04513-000, São Paulo, Brazil
 In association with

inter-consult ltd
 P O Box 423, Dar es Salaam, Tanzania
 Tel: + 255-22-2772424/2772477
 Email: info@interconsult-tz.com
 RCP Consultoria e Participações Ltda.
 Rua Antônio Bragança, 615
 CEP 04715-003, São Paulo, Brazil
 Email: info@rccconsultoria.com.br

LEGEND:
 + TREES
ABUTTING PROPERTIES:
 ■ RESIDENTIAL PROPERTIES (at ground floor)
 ■ COMMERCIAL ACTIVITY TYPES
 ■ RESTAURANT/BAR/FOOD & LEISURE/HOTEL
 ■ VEHICLE RELATED SERVICES (EXCLUDING PETROL STATIONS)
 ■ PETROL STATIONS
 ■ OTHER RETAIL OR SERVICES (INCLUDING BANKS AND FINANCIAL INSTITUTIONS AND MARKETS)
 ■ RELIGIOUS BUILDINGS
 ■ PUBLIC/INSTITUTIONAL BUILDINGS (INCLUDING SCHOOLS)
 ■ INDUSTRIAL
 ■ OTHER (HOSPITALS, FIRE STATION, ETC)

CLASSIFICATION BY HEIGHT:
 □ 1 OR 2 STOREY BUILDINGS
 □ 3 OR 4 STOREY BUILDINGS
 □ 5 OR MORE STOREY BUILDINGS
 ■ UPPER STOREY PREDOMINANT USE:
 ■ RESIDENTIAL
 ■ COMMERCIAL

USES INSIDE THE RIGHT-OF-WAY (ROW)
 ■ AREA OCCUPIED BY BARS AND RESTAURANTS
 ■ OTHER ROW AREAS OCCUPIED BY WAITING COMMERCE
 ■ ROW AREAS OCCUPIED BY STREET VENDORS (PORTABLE)
 ● ROW AREAS OCCUPIED BY FIXED/AUTHORIZED STREET VENDORS OR EQUIVALENT
 ● DALADALA STOPS
 ● DALADALA PARKING AREAS
 ● TAXI SPOTS
 ● TRUCK PARKING AREAS
 ● OTHER PARKING AREAS (INDICATE USE)
 ● OTHER (INDICATE USE)

located by:
 Surveyed by: Juliana C Antunes
 Designed:
 Drawn by: Fabrizia Oliveri
 Checked by:
 Approved by:
 Scale: 1:250

Project:
DAR RAPID TRANSIT (DART)
 Subject:
**LAND USE IDENTIFICATION
 DIRECT AFFECTED AREA - DAA**
 Date: January 2007
 Drg No. T301-CE-RD-LAD-18 REV 00

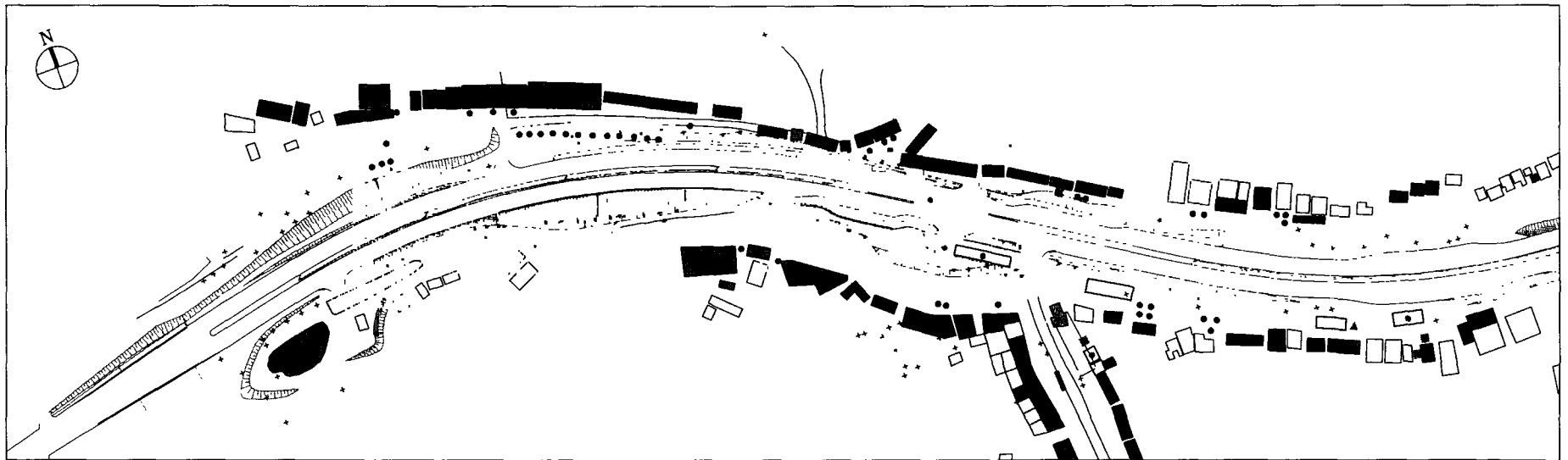
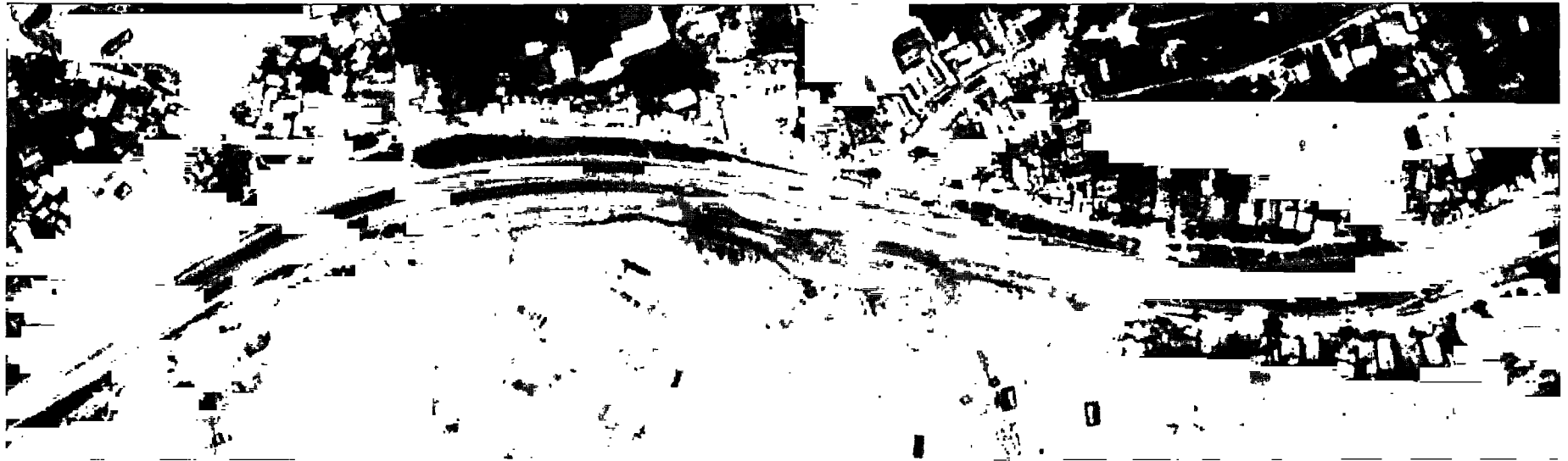

Client:

DAR ES SALAAM CITY COUNCIL
 P O Box 9084, Dar es Salaam, Tanzania
 Tel: + 255-22-2123551/6
 Email: cd@dcc.go.tz

Consultant:
LOGIT
 Logit Engenharia Consultiva Ltda
 Av. Esplanada, 490, 8. Andar
 CEP 05413-000, São Paulo, Brazil
 In association with
inter-consult ltd
 P O Box 423, Dar es Salaam, Tanzania
 Tel: + 255-22-2772454/2772477
 Email: info@interconsult-tz.com
 ZEP Consultoria e Participações Ltda.
 Rua Andreia Brumanna, 815
 CEP 04713-000, São Paulo, Brazil
 Email: jpe@zephonauficiis.com.br

LEGEND:
 + TREES
ABUTTING PROPERTIES:
 ■ RESIDENTIAL PROPERTIES (at ground floor)
COMMERCIAL ACTIVITY TYPES:
 ■ RESTAURANT/BAR/FOOD & LEISURE/HOTEL
 ■ VEHICLE RELATED SERVICES (EXCLUDING PETROL STATIONS)
 ■ PETROL STATIONS
 ■ OTHER RETAIL OR SERVICES (INCLUDING BANKS AND FINANCIAL INSTITUTIONS AND MARKETS)
 ■ RELIGIOUS BUILDINGS
 ■ PUBLIC/INSTITUTIONAL BUILDINGS (INCLUDING SCHOOLS)
 ■ INDUSTRIAL
 ■ OTHER (HOSPITALS, FIRE STATION, ETC)

CLASSIFICATION BY HEIGHT
 1 OR 2 STOREY BUILDINGS
 3 OR 4 STOREY BUILDINGS
 5 OR MORE STOREY BUILDINGS
UPPER STOREY PREDOMINANT USE:
 ■ RESIDENTIAL
 ■ COMMERCIAL

USES INSIDE THE RIGHT-OF-WAY (ROW)
 ▲ AREA OCCUPIED BY BARS AND RESTAURANTS
 ■ OTHER ROW AREAS OCCUPIED BY RESTAURANT COMMERCE
 ■ ROW AREAS OCCUPIED BY STREET VENDORS (PORTABLE VENDORS OR EQUIPMENT)
 ● DALADADA STOPS
 ● DALADADA PARKING AREAS
 ● TAXI STOPS
 ● TRUCK PARKING AREAS
 ● OTHER PARKING AREAS (INDICATE USE)
 ● OTHER (INDICATE USE)

located by:
 Surveyed by: Juliana C. Antunes
 Designed by:
 Drawn by: Fabrizia Oliverii
 Checked by:
 Approved by:
 Scale: 1:2500

Project:
DAR RAPID TRANSIT (DART)
 Subject:
**LAND USE IDENTIFICATION
 DIRECT AFFECTED AREA - DAA**
 Date: January 2007
 Drg No. T301-CE-RD-LAID-19 REV 00

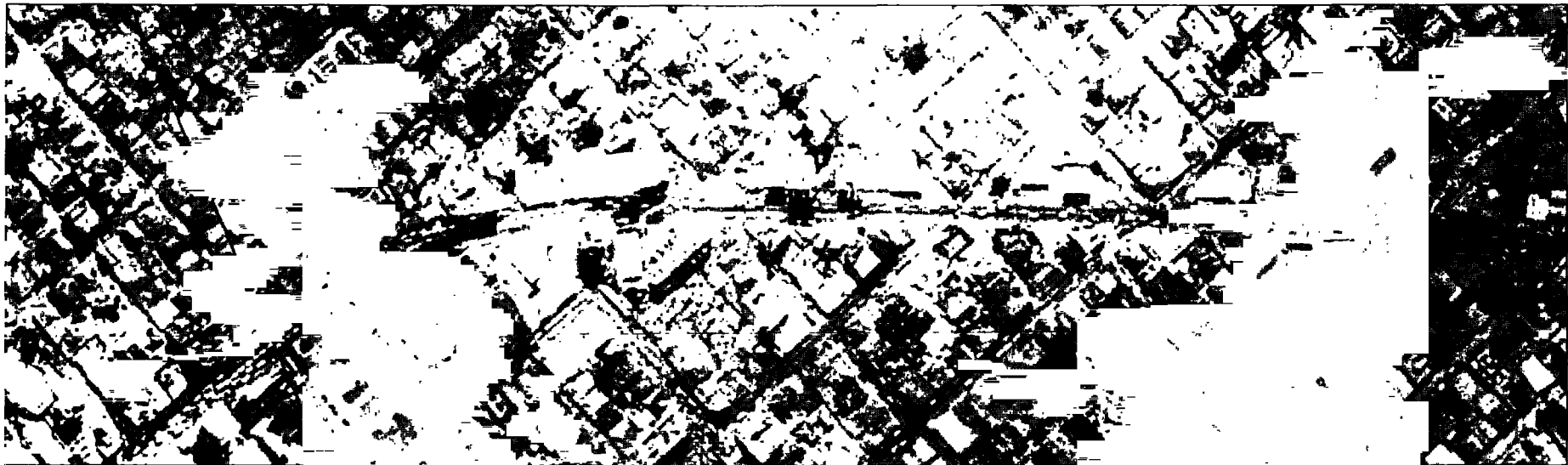

Client:



DAR ES SALAAM CITY COUNCIL
 P O Box 9084, Dar es Salaam, Tanzania
 Tel: + 255-22-2123551/6
 Email: cd@dcc.go.tz

Consultant:



Logit Engenharia Consultiva Ltda
 Av. Estado do Rio de Janeiro, 800, B. Andar
 CEP 05413-000, São Paulo, Brazil



inter-consult ltd
 P O Box 423, Dar es Salaam, Tanzania
 Tel: + 255-22-277424/277477
 Email: info@interconsult.com



RPP Consultoria e Participações Ltda.
 Av. António Bragança, 813
 CEP 04710-000, São Paulo, Brazil
 Email: rpp@rppconsultoria.com.br

LEGEND:

- TREES
- ABUTTING PROPERTIES
- RESIDENTIAL PROPERTIES (at ground floor)
- COMMERCIAL ACTIVITY TYPES:
 - RESTAURANT/BAR/FOOD & LEISURE/HOTEL
 - VEHICLE RELATED SERVICES (EXCLUDING PETROL STATIONS)
 - PETROL STATIONS
 - OTHER RETAIL OR SERVICES (INCLUDING BANKS AND FINANCIAL INSTITUTIONS AND MARKETS)
 - RELIGIOUS BUILDINGS
 - PUBLIC/INSTITUTIONAL BUILDINGS (INCLUDING SCHOOLS)
 - INDUSTRIAL
 - OTHER (HOSPITALS, FIRE STATION, ETC)

CLASSIFICATION BY HEIGHT:

- 1 OR 2 STOREY BUILDINGS
- 3 OR 4 STOREY BUILDINGS
- 5 OR MORE STOREY BUILDINGS
- 5+ STOREY PREDOMINANT USE:
- RESIDENTIAL
- COMMERCIAL



USES INSIDE THE RIGHT-OF-WAY (ROW)

- ▲ AREA OCCUPIED BY BARS AND RESTAURANTS
- OTHER ROW AREAS OCCUPIED BY MULTITYPE COMMERCE
- ROW AREAS OCCUPIED BY STREET VENDORS (FORBIDDEN)
- ROW AREAS OCCUPIED BY FIRE/AUTHORIZED STREET VENDORS OR EQUIPMENT
- DALADALA STOPS
- DALADALA PARKING AREAS
- TAXI SPOTS
- TRUCK PARKING AREAS
- OTHER PARKING AREAS (INDICATE USE)
- OTHER (INDICATE USE)

located by:
 Surveyed by: Juliana C. Antunes
 Designed:
 Drawn by: Fabricia Oliverii
 Checked by:
 Approved by:
 Scale: 1:2500

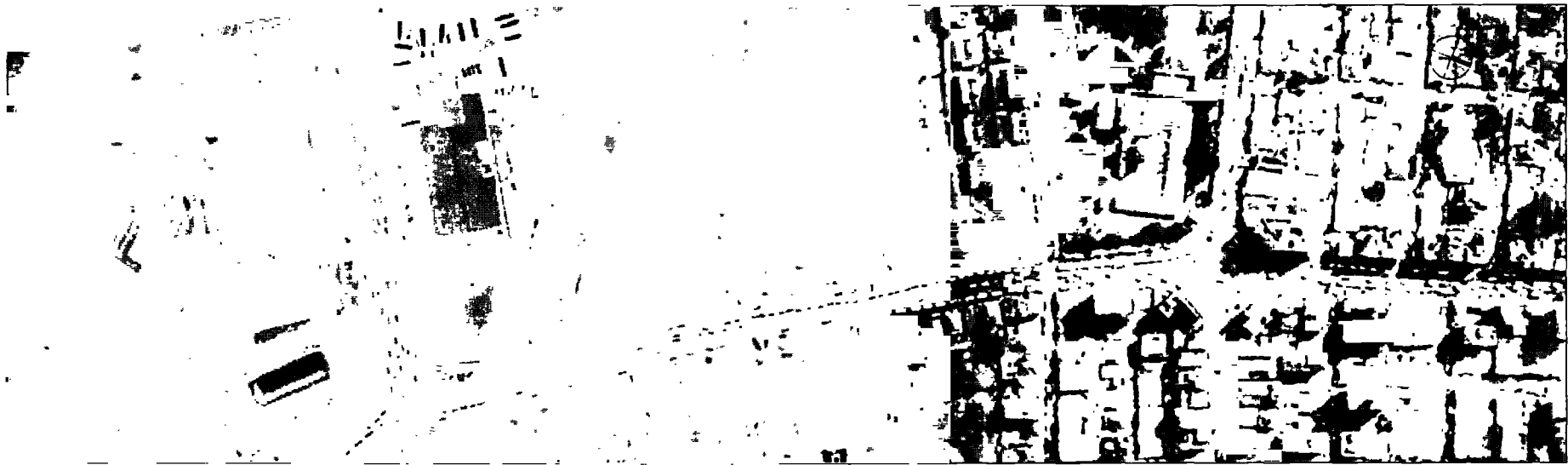
Project:
 DAR RAPID TRANSIT (DART)
 Subject:
 LAND USE IDENTIFICATION
 DIRECT AFFECTED AREA - DAA
 Date: January 2007
 Drg No. T301-CE-RD-LAID-20
 REV 00



<p>Client:</p>  <p>DAR ES SALAAM CITY COUNCIL P O Box 9084, Dar es Salaam, Tanzania Tel: + 255-22-2123551/6 Email: cd@dcc.go.tz</p>	<p>Consultant:</p>  <p>Logit Engenharia Consultiva Ltda Rua Lacerda de Almeida 880, 8 - Andar CEP 04623-000, São Paulo, Brazil in association with inter-consult ltd P O Box 483, Dar es Salaam, Tanzania Tel: + 255-22-277424/277477 Email: info@interconsult.com</p>  <p>RUP Consultoria e Participações Ltda. Rua Antônio Brás, 815 CEP 04715-000, São Paulo, Brazil Email: rup@rupoconsultoria.com.br</p>	<p>LEGEND:</p> <p>• TREES</p> <p>▲ ADJUTING PROPERTIES:</p> <p>RESIDENTIAL PROPERTIES (at ground floor)</p> <p>OCUPATIONAL ACTIVITY TYPES:</p> <p>RESTAURANT/BAR/FOOD & LEISURE/HOTEL</p> <p>VEHICLE RELATED SERVICES (INCLUDING PETROL STATIONS)</p> <p>PETROL STATIONS</p> <p>OTHER RETAIL OR SERVICES (INCLUDING BANKS AND FINANCIAL INSTITUTIONS AND MARKETS)</p> <p>RESIDENTIAL BUILDINGS</p> <p>PUBLIC/INSTITUTIONAL BUILDINGS (INCLUDING SCHOOLS)</p> <p>INDUSTRIAL</p> <p>OTHER (HOSPITALS, FIRE STATION, ETC)</p>	<p>CLASSIFICATION BY HEIGHT:</p> <p>1 OR 2 STOREY BUILDINGS</p> <p>3 OR 4 STOREY BUILDINGS</p> <p>5 OR MORE STOREY BUILDINGS</p> <p>UPPER STOREY PREDOMINANT USE:</p> <p>RESIDENTIAL</p> <p>COMMERCIAL</p>	<p>USES INSIDE THE RIGHT-OF-WAY (ROW)</p> <p>▲ AREA OCCUPIED BY BARS AND RESTAURANTS</p> <p>■ OTHER ROW AREAS OCCUPIED BY HAULING COMMERCIAL</p> <p>ROW AREAS OCCUPIED BY STREET VENDORS (PORTABLE)</p> <p>● ROW AREAS OCCUPIED BY FIXED/AUTHORIZED STREET VENDORS OR EQUIVALENT</p> <p>● DAKADALA STOPS</p> <p>● DAKADALA PARKING AREAS</p> <p>● TAXI SPOTS</p> <p>● TRUCK PARKING AREAS (INDICATE USE)</p> <p>● OTHER (INDICATE USE)</p>	<p>located by:</p> <p>Surveyed by: Juliana C. Antunes</p> <p>Designed:</p> <p>Drawn by: Fabrizia Oliveira</p> <p>Checked by:</p> <p>Approved by:</p> <p>Scale: 1:2500</p>	<p>Project:</p> <p>DAR RAPID TRANSIT (DART)</p> <p>Subject:</p> <p>LAND USE IDENTIFICATION DIRECT AFFECTED AREA - DAA</p> <p>Date: January 2007</p> <p>Drq No. T301-CE-RD-LAID-21</p> <p>REV 00</p>
					<p>located by:</p> <p>Surveyed by: Juliana C. Antunes</p> <p>Designed:</p> <p>Drawn by: Fabrizia Oliveira</p> <p>Checked by:</p> <p>Approved by:</p> <p>Scale: 1:2500</p>	<p>Project:</p> <p>DAR RAPID TRANSIT (DART)</p> <p>Subject:</p> <p>LAND USE IDENTIFICATION DIRECT AFFECTED AREA - DAA</p> <p>Date: January 2007</p> <p>Drq No. T301-CE-RD-LAID-21</p> <p>REV 00</p>

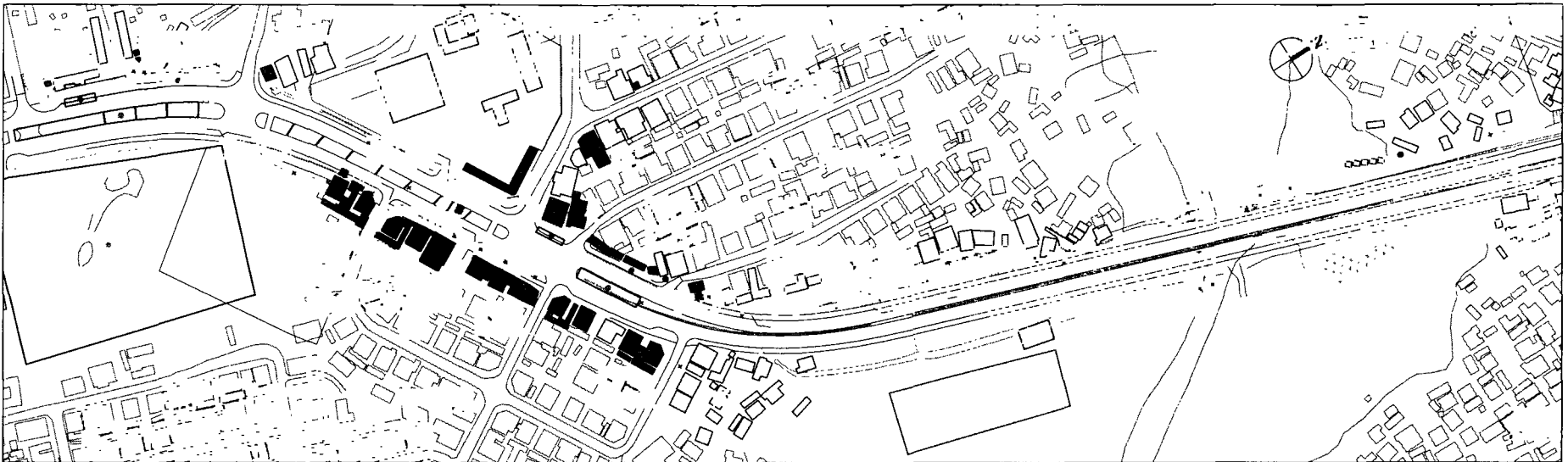
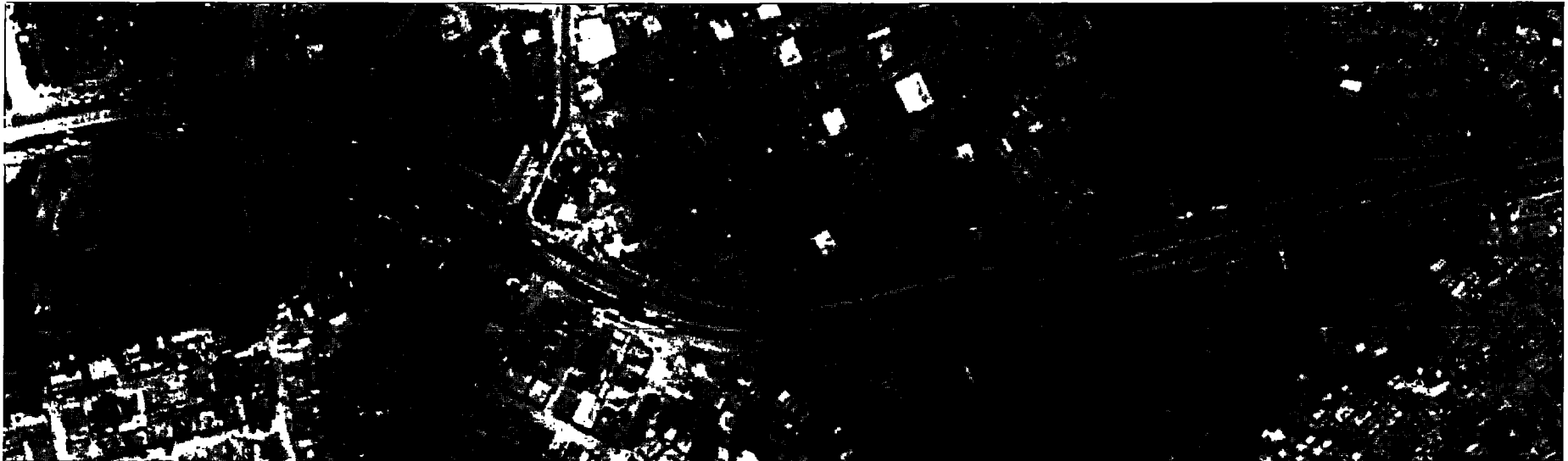

Client:

DAR ES SALAAM CITY COUNCIL
 P O Box 9084, Dar es Salaam, Tanzania
 Tel: + 255-22-2123551/6
 Email: cd@dcc.go.tz

Consultant:
LOGIT
 Logit Engenharia Consultiva Ltda
 Av. Ladeira Botafogo 880, 6 Andar
 CEP 04513-000, São Paulo, Brasil
 In association with
inter-consult ltd
 P O Box 423, Dar es Salaam, Tanzania
 Tel: + 255-22-2772424/2772477
 Email: info@interconsult-ltd.com
 RSP Consultoria e Participações Ltda.
 Rua Andrión Bragança, 815
 CEP 04718-000, São Paulo, Brasil
 Email: info@rspconsultoria.com.br

LEGEND:
 + TREES
 ABUTTING PROPERTIES:
 RESIDENTIAL PROPERTIES (at ground floor)
 COMMERCIAL ACTIVITY TYPES:
 RESTAURANT/BAR/FOOD & LEISURE/HOTEL
 VEHICLE RELATED SERVICES (EXCLUDING PETROL STATIONS)
 PETROL STATIONS
 OTHER RETAIL OR SERVICES (INCLUDING BANKS AND FINANCIAL INSTITUTIONS AND MARKETS)
 RELIGIOUS BUILDINGS
 PUBLIC/INSTITUTIONAL BUILDINGS (INCLUDING SCHOOLS)
 INDUSTRIAL
 OTHER (HOSPITALS, FIRE STATION, ETC)

CLASSIFICATION BY HEIGHT:
 1 OR 2 STOREY BUILDINGS
 3 OR 4 STOREY BUILDINGS
 5 OR MORE STOREY BUILDINGS
 UPPER STOREY PREDOMINANT USE
 RESIDENTIAL
 COMMERCIAL

USES INSIDE THE RIGHT-OF-WAY (ROW)
 AREA OCCUPIED BY BARS AND RESTAURANTS
 OTHER ROW AREAS OCCUPIED BY ABUTTING COMMERCE
 ROW AREAS OCCUPIED BY STREET VENDORS (PORTABLE)
 ROW AREAS OCCUPIED BY FIXED/AUTHORIZED STREET VENDORS OR EQUIPMENT
 DAKADALA STOPS
 DAKADALA PARKING AREAS
 TAXI SPOTS
 TRUCK PARKING AREAS
 OTHER PARKING AREAS (INDICATE USE)
 OTHER (INDICATE USE)

located by:	Project:
Surveyed by: Juliana C. Antunes	DAR RAPID TRANSIT (DART)
Designed:	Subject:
Drawn by: Fabrizio Oliveri	LAND USE IDENTIFICATION DIRECT AFFECTED AREA - DA
Checked by:	Date: January 2007
Approved by:	Org No. T301-CE-RD-LAID-22
Scale: 1:2500	REV 00

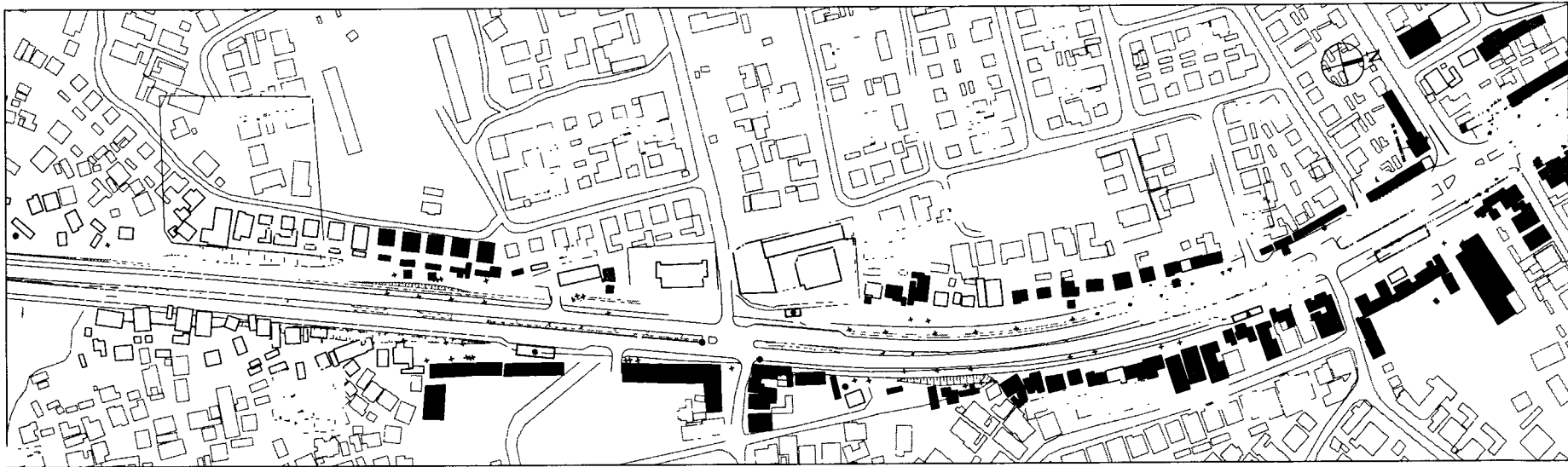

<p>Client:</p> <p>DAR ES SALAAM CITY COUNCIL P O Box 9084, Dar es Salaam, Tanzania Tel: + 255-22-2123551/6 Email: cd@dcc.go.tz</p>	<p>Consultant:</p> <p>LOGIT Logit Engenharia Consultiva Ltda Av. Embaixador Moraes 880, 8. Andar CEP 05423-000, São Paulo, Brazil</p> <p>In association with</p> <p>inter-consult ltd P O Box 423, Dar es Salaam, Tanzania Tel: + 255-22-2772454/2772477 Email: info@interconsult-tz.com</p> <p>JOP Consultoria e Participações Ltda. Rua Andrade Brilhante, 815 CEP 04718-003, São Paulo, Brazil Email: jop@jopconsultoria.com.br</p>	<p>LEGEND:</p> <p>• TREES</p> <p>ABUTTING PROPERTIES:</p> <p>RESIDENTIAL PROPERTIES (at ground floor)</p> <p>COMMERCIAL ACTIVITY TYPES:</p> <p>RESTAURANT/BAR/FOOD & LEISURE/HOTEL</p> <p>VEHICLE RELATED SERVICES (EXCLUDING PETROL STATIONS)</p> <p>PETROL STATIONS</p> <p>OTHER RETAIL OR SERVICES (INCLUDING BANKS AND FINANCIAL INSTITUTIONS AND MARKETS)</p> <p>RELIGIOUS BUILDINGS</p> <p>PUBLIC/INSTITUTIONAL BUILDINGS (INCLUDING SCHOOLS)</p> <p>INDUSTRIAL</p> <p>OTHER (HOSPITALS, FIRE STATION, ETC)</p>	<p>CLASSIFICATION BY HEIGHT:</p> <p>1 OR 2 STOREY BUILDINGS</p> <p>3 OR 4 STOREY BUILDINGS</p> <p>5 OR MORE STOREY BUILDINGS</p> <p>UPPER STOREY PREDOMINANT USE:</p> <p>RESIDENTIAL</p> <p>COMMERCIAL</p>	<p>USES INSIDE THE RIGHT-OF-WAY (ROW)</p> <p>AREA OCCUPIED BY BARS AND RESTAURANTS</p> <p>OTHER ROW AREAS OCCUPIED BY ABUTTING COMMERCE</p> <p>ROW AREAS OCCUPIED BY STREET VENDORS (PORTABLE VENDORS OR EQUIVALENT)</p> <p>DALADALA STOPS</p> <p>DALADALA PARKING AREAS</p> <p>TAXI SPOTS</p> <p>TRUCK PARKING AREAS</p> <p>OTHER PARKING AREAS (INDICATE USE)</p> <p>OTHER (INDICATE USE)</p>	<p>located by:</p> <p>Surveyed by: Juliana C Antunes</p> <p>Designed by:</p> <p>Drawn by: Fabrizia Oliverii</p> <p>Checked by:</p> <p>Approved by:</p> <p>Scale: 1:250</p>	<p>Project:</p> <p>DAR RAPID TRANSIT (DART)</p> <p>Subject:</p> <p>LAND USE IDENTIFICATION DIRECT AFFECTED AREA - DMA</p> <p>Date: January 2007</p> <p>Drq No. T301-CE-RD-LAID-23</p> <p>REV 00</p>
					<p>inter-consult ltd</p>	

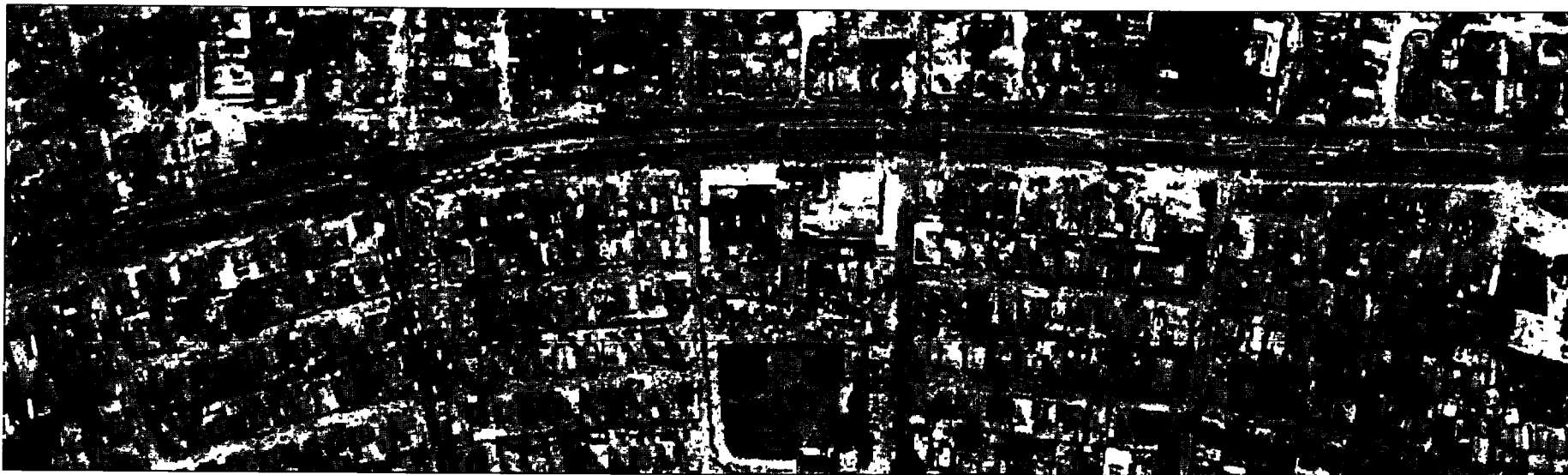

Client:



DAR ES SALAAM CITY COUNCIL
P O Box 9084, Dar es Salaam, Tanzania
Tel: + 255-22-2123551/6
Email: cd@dcc.go.tz

Consultant:



Logit Engenharia Consultiva Ltda
Av. Embaixador Nery 280, 8 andar
CEP 05423-000, São Paulo, Brazil

In association with

inter-consult Ltd

P O Box 423, Dar es Salaam, Tanzania
Tel: + 255-22-277424/277477
Email: info@interconsult-tz.com



ZUP Consultoria e Participações Ltda.
Rua Andrade Brilhante, 815
CEP 04718-003, São Paulo, Brazil
Email: info@zupconsultoria.com.br

LEGEND:

- + TREES
- ADULTING PROPERTIES:
- RESIDENTIAL PROPERTIES (at ground floor)
- COMMERCIAL ACTIVITY TYPES:
- RESTAURANT/BAR/FOOD & LEISURE/HOTEL
- VEHICLE RELATED SERVICES (EXCLUDING PETROL STATIONS)
- PETROL STATIONS
- OTHER RETAIL OR SERVICES (INCLUDING BANKS AND FINANCIAL INSTITUTIONS AND MARKETS)
- RELIGIOUS BUILDINGS
- PUBLIC/INSTITUTIONAL BUILDINGS (INCLUDING SCHOOLS)
- INDUSTRIAL
- OTHER (HOSPITALS, FIRE STATION, ETC)

- CLASSIFICATION BY HEIGHT:
- 1 OR 2 STOREY BUILDINGS
 - 3 OR 4 STOREY BUILDINGS
 - 5 OR MORE STOREY BUILDINGS
- UPPER STOREY PREDOMINANT USE:
- RESIDENTIAL
 - COMMERCIAL

USES INSIDE THE RIGHT-OF-WAY (ROW)

- AREA OCCUPIED BY BARS AND RESTAURANTS
- OTHER ROW AREAS OCCUPIED BY AMBITIOUS COMMERCE
- ROW AREAS OCCUPIED BY STREET VENDORS (PORTABLE VENDORS OR EQUIPMENT)
- DALADALA STOPS
- DALADALA PARKING AREAS
- TAXI SPOTS
- TRUCK PARKING AREAS
- OTHER PARKING AREAS (INDICATE USE)
- OTHER (INDICATE USE)

located by:

Surveyed by: Juliana C. Antunes

Designed by:

Drawn by: Fabrizia Oliveri

Checked by:

Approved by:

Scale:

1:250

Project:

DAR RAPID TRANSIT (DART)

Subject:

LAND USE IDENTIFICATION
DIRECT AFFECTED AREA - DAA

Date:



January 2007

Drw No.

T301-CE-RD-LAID-24

REV 00



Client:  DAR ES SALAAM CITY COUNCIL P O Box 9084, Dar es Salaam, Tanzania Teli: + 255-22-2123551/6 Email: cd@dcc.go.tz	Consultant:  LOGIT Logit Engenharia Consultiva Ltda Rua Antonio de Almeida, 8 - Jd. Morumbi São Paulo - SP - 05623-000 - Brasil Fone: +55 (11) 5082-1000 In consultation with  inter-consult Ltd P O Box 423, Dar es Salaam, Tanzania Tel: + 255-22-277424/277427	LEGEND: ADULTING PROPERTIES: RESIDENTIAL PROPERTIES (of ground floor) RESTAURANT/BAR/CAFE RESTAURANT/BAR/CAFE & LEISURE/RETAIL VEHICLE RELATED SERVICES (EXCLUDING PETROL STATIONS) PETROL STATIONS FINANCIAL INSTITUTIONS AND MARKETS FINANCIAL SERVICES INCLUDING BANKS AND RELIGIOUS BUILDINGS INDUSTRIAL, WAREHOUSES, BUILDINGS (INCLUDING SCHOOLS) OTHER HOSPITALS, FIRE STATION, ETC.	CLASSIFICATION BY HEIGHT: 1 or 2 STOREY BUILDINGS 3 or 4 STOREY BUILDINGS 5 or 6 STOREY BUILDINGS 7 or 8 STOREY BUILDINGS 9 or 10 STOREY BUILDINGS COMMERCIAL	USES INSIDE THE RIGHT-OF-WAY (ROW) AREA OCCUPIED BY BARS AND RESTAURANTS OTHER ROW AREAS OCCUPIED BY RESIDENTIAL COMMERCIAL ROW AREAS OCCUPIED BY RESIDENTIAL COMMERCIAL ROW AREAS OCCUPIED BY RESIDENTIAL COMMERCIAL WALKWAYS OR SIDEWALKS BALCONY TERRACE AREAS TALL SPACES OTHER PERMITTED AREAS (INDICATE USE) OTHER (INDICATE USE)	located by: Surveyed by: Juliana C. Antunes Designed: Drawn by: Fabrizia Oliveri Checked by: Approved by:	Project: DAR RAPID TRANSIT (DART)
					Date: January 2007	Dwg No: T301-CE-RD-LAND-25

**DART – Dar es Salaam Rapid
Transit**

**Environmental and Social
Impact Assessment**

**Land Use Photographic
Report**

Comments:

**Figure 1 – Sokoine Drive and Saint
Joseph' Cathedral**

Figure 2 – Kivukoni Waterfront

Figure 3 – Kivukoni Water Front

Date: February/2007

1/9

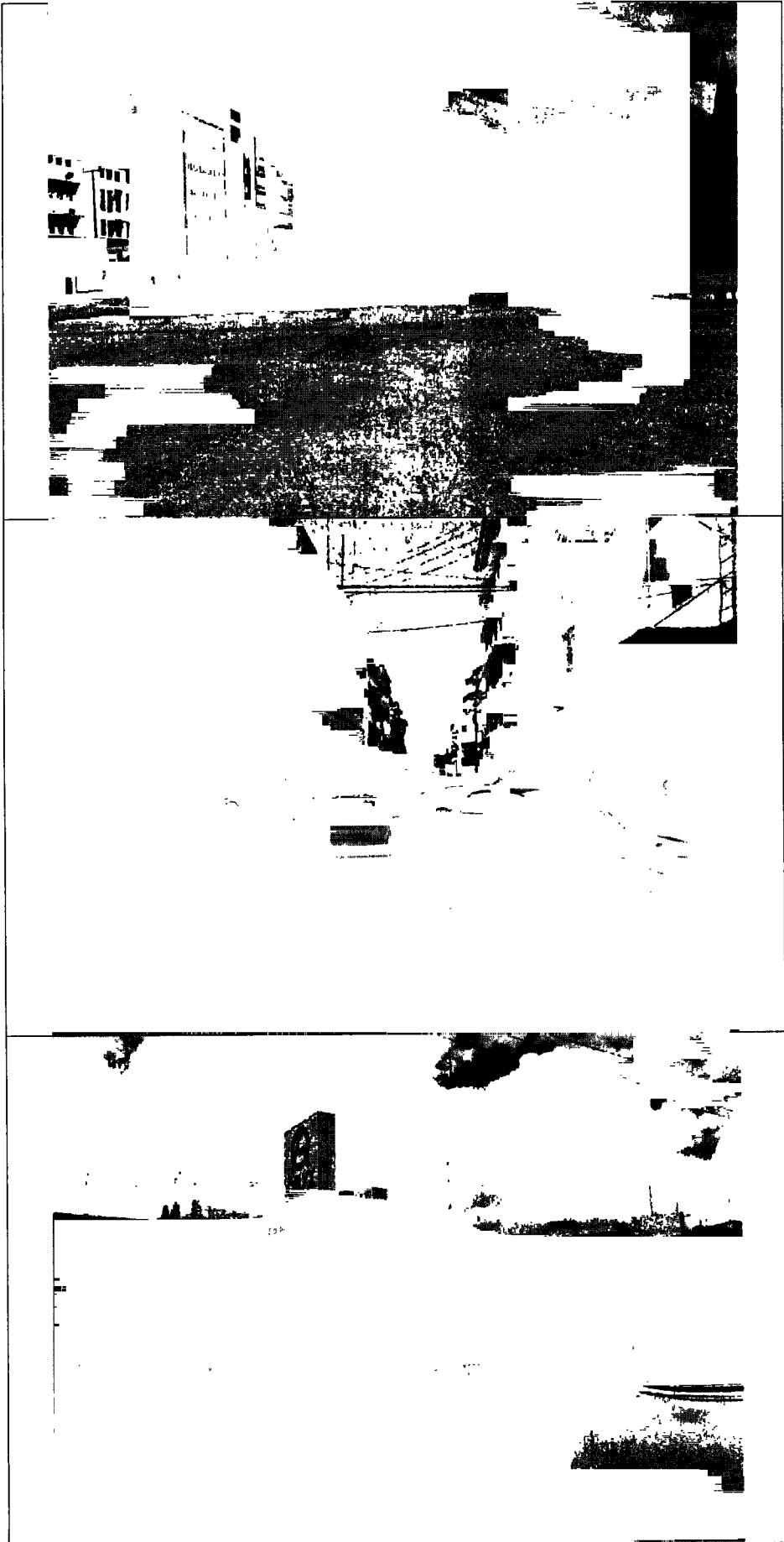

DART – Dar es Salaam Rapid Transit

Environmental and Social Impact Assessment

Land Use Photographic Report

Comments:

Figure 4 – Parking Area in front of the City Council Hall

Figure 5 – CBD Area

Figure 6 – Petrol Station at Morogoro Road X Libya Street

Date: February/2007
2/9

**DART – Dar es Salaam Rapid
Transit**

**Environmental and Social
Impact Assessment**

**Land Use Photographic
Reports**

Comments:

Figure 7: Vedic Temple at Morogoro Road, between Bibititi and Libya St

Figure 8: Morogoro Rd, between Bibititi Rd and Lumumba St

Figure 9: Fire Station Wall

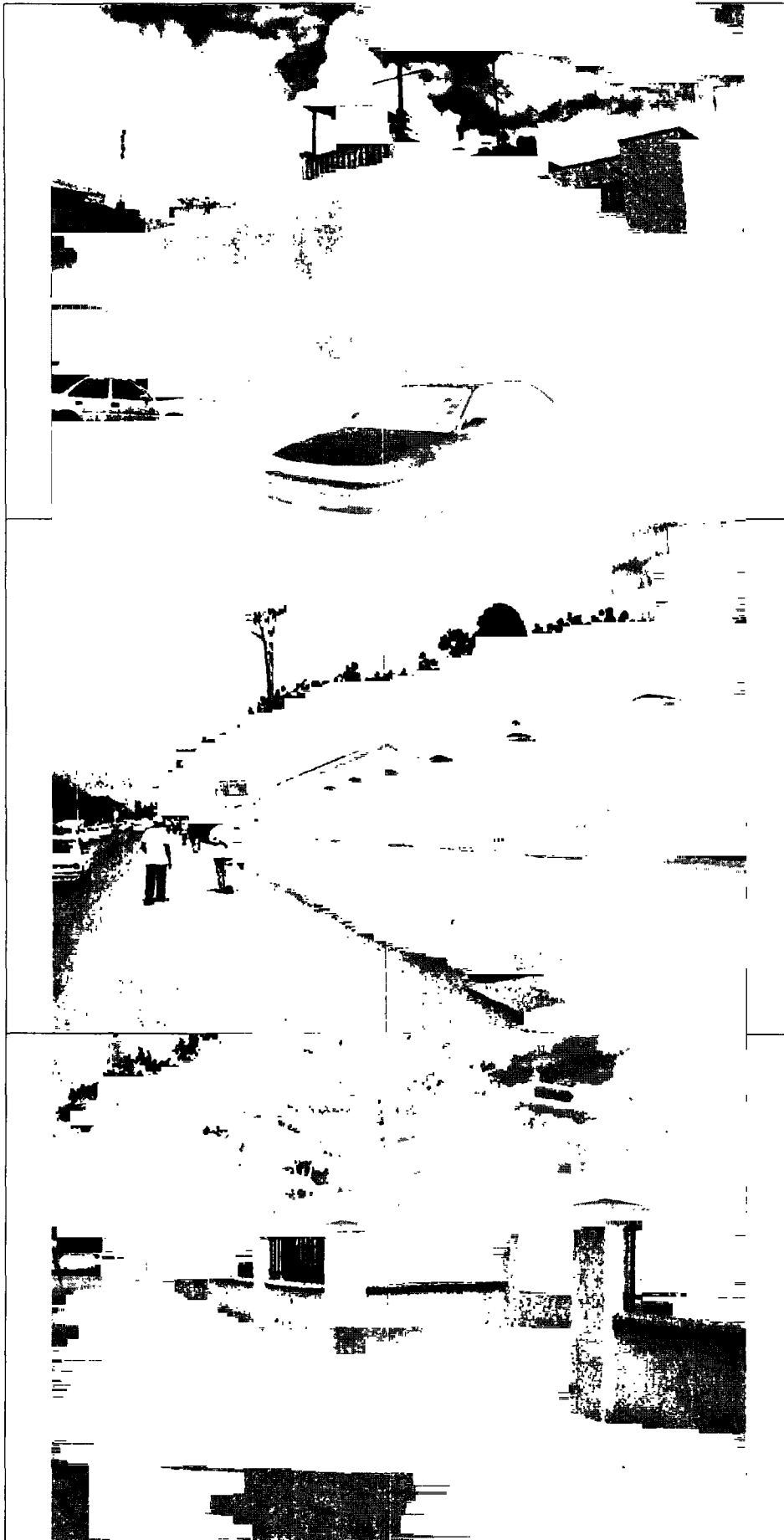

Date: February/2007
3/9

**DART – Dar es Salaam Rapid
Transit**

**Environmental and Social
Impact Assessment**

**Land Use Photographic
Report**

Comments:

Figure 10: Building at Morogoro Rd,
between Msimbazi St and United Nations

Figure 11: Morogoro Rd, between
Jangwany Valley and Magomeni

Figure 12: Morogoro Rd, between
Jangwany Valley and Magomeni

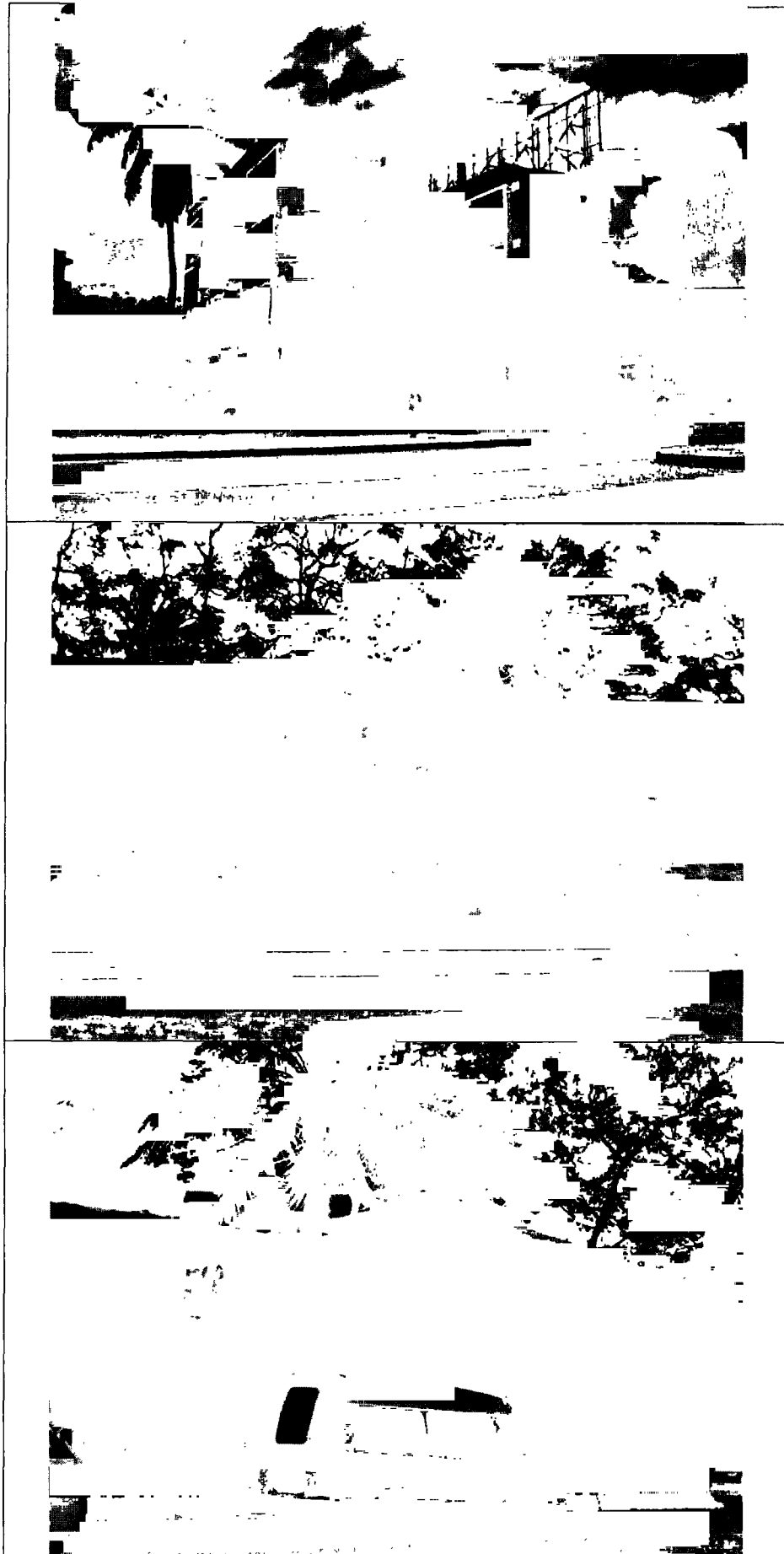

Date: February/2007
4/9

**DART – Dar es Salaam Rapid
Transit**

**Environmental and Social
Impact Assessment**

**Land Use Photographic
Report**

Comments:

Figure 13: Urafiki Residential Flats

Figure 14: Plants – fixed Street vendors
in front of Urafiki Co Ltda

Figure 15: Morogoro Rd – Between
Ubungo and Kimara

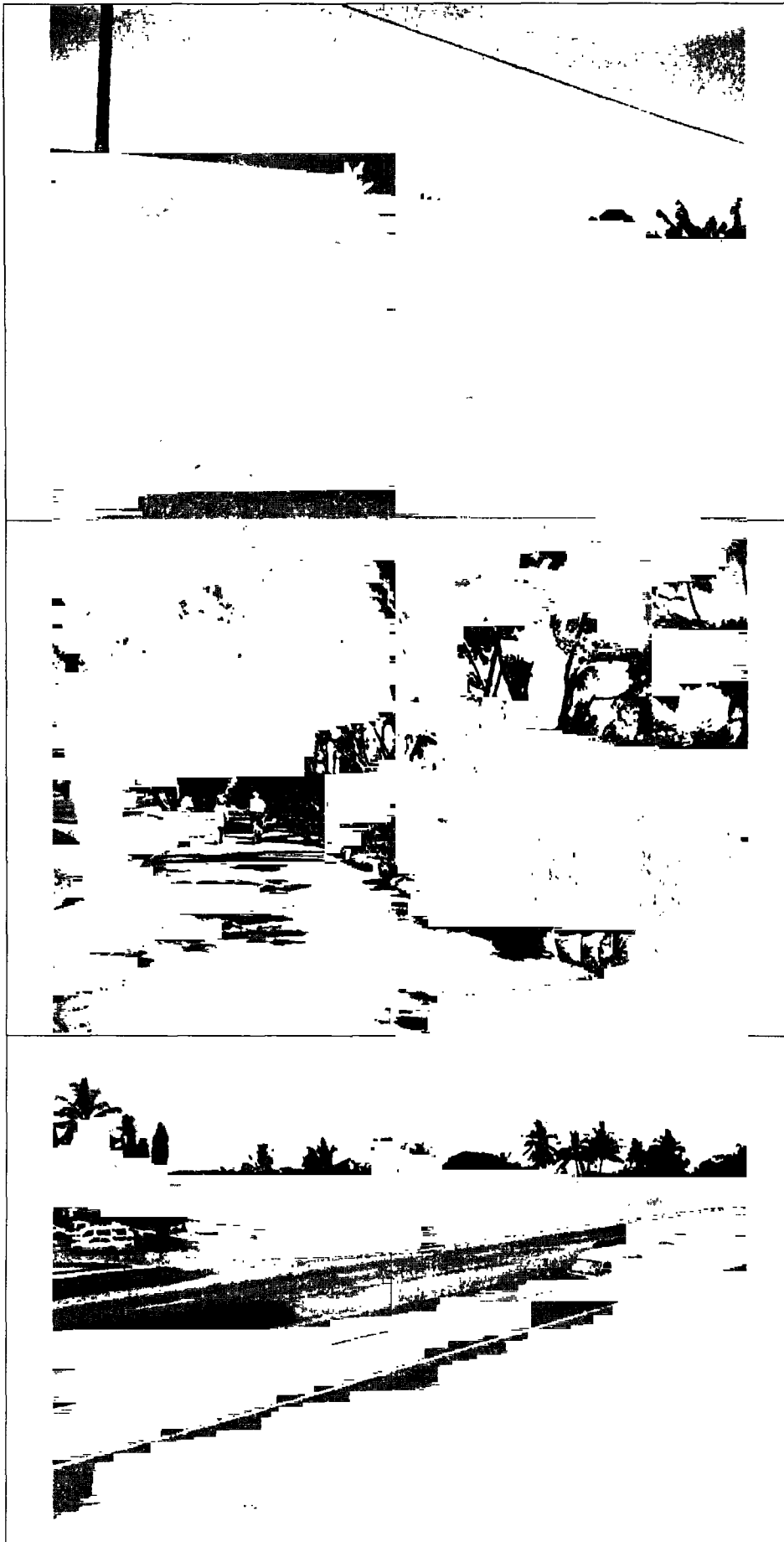

Date: February/2007
5/9

**DART – Dar es Salaam Rapid
Transit**

**Environmental and Social
Impact Assessment**

**Land Use Photographic
Report**

Comments:

Figure 16: Typical commercial unit –
Morogoro Road

Figure 17 - Typical commercial centrality
– Morogoro Road - Kimara

Figure 18 - Typical commercial unit –
Morogoro Road - Kimara

Date: February/2007
6/9

**DART – Dar es Salaam Rapid
Transit**

**Environmental and Social
Impact Assessment**

**Land Use Photographic
Report**

Comments:

Figure 16: Typical commercial unit –
Morogoro Road

Figure 17 - Typical commercial unit –
Morogoro Road

Figure 18 - Typical commercial unit –
Morogoro Road - Kimara

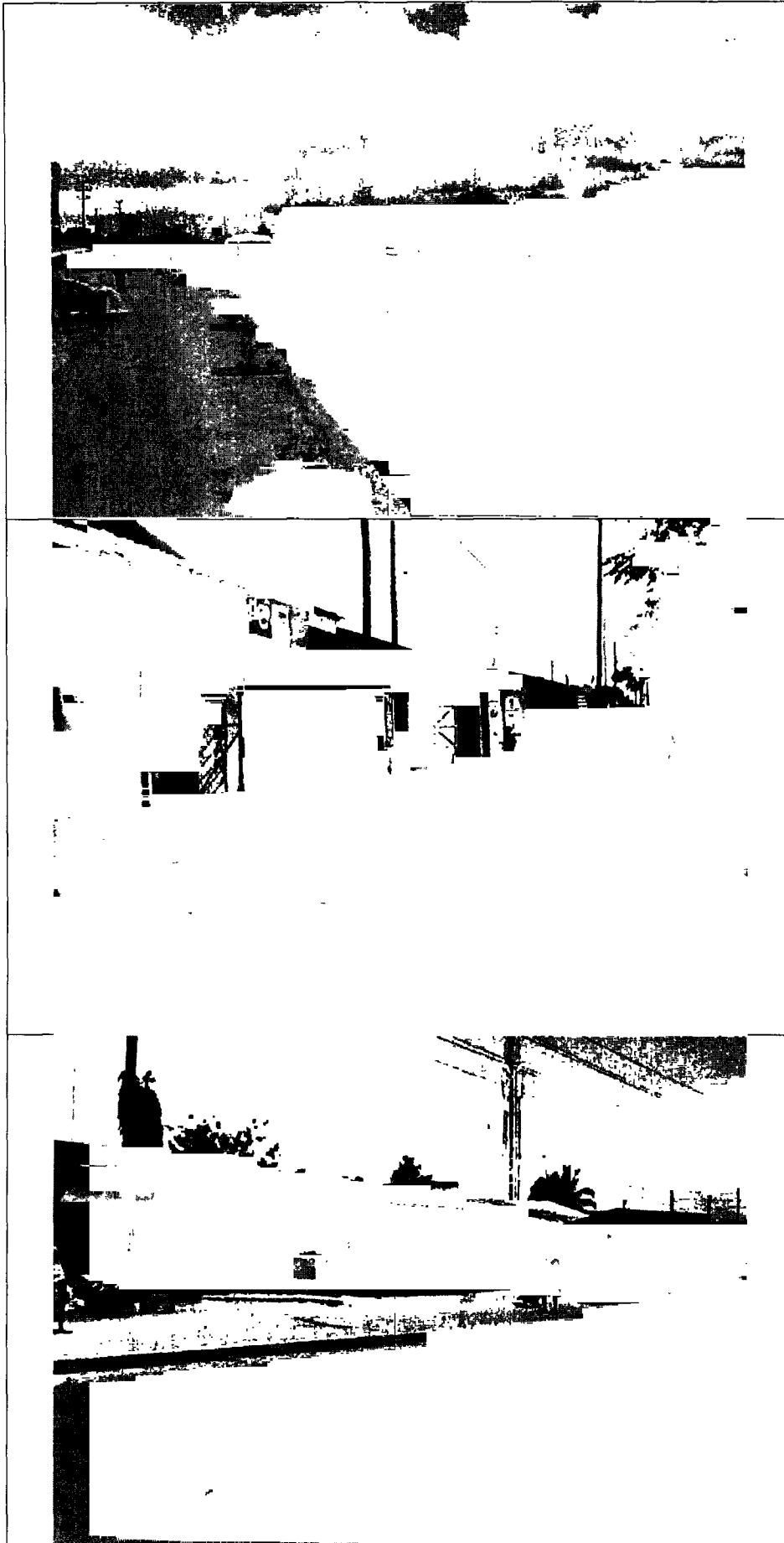

Date: February/2007
7/9

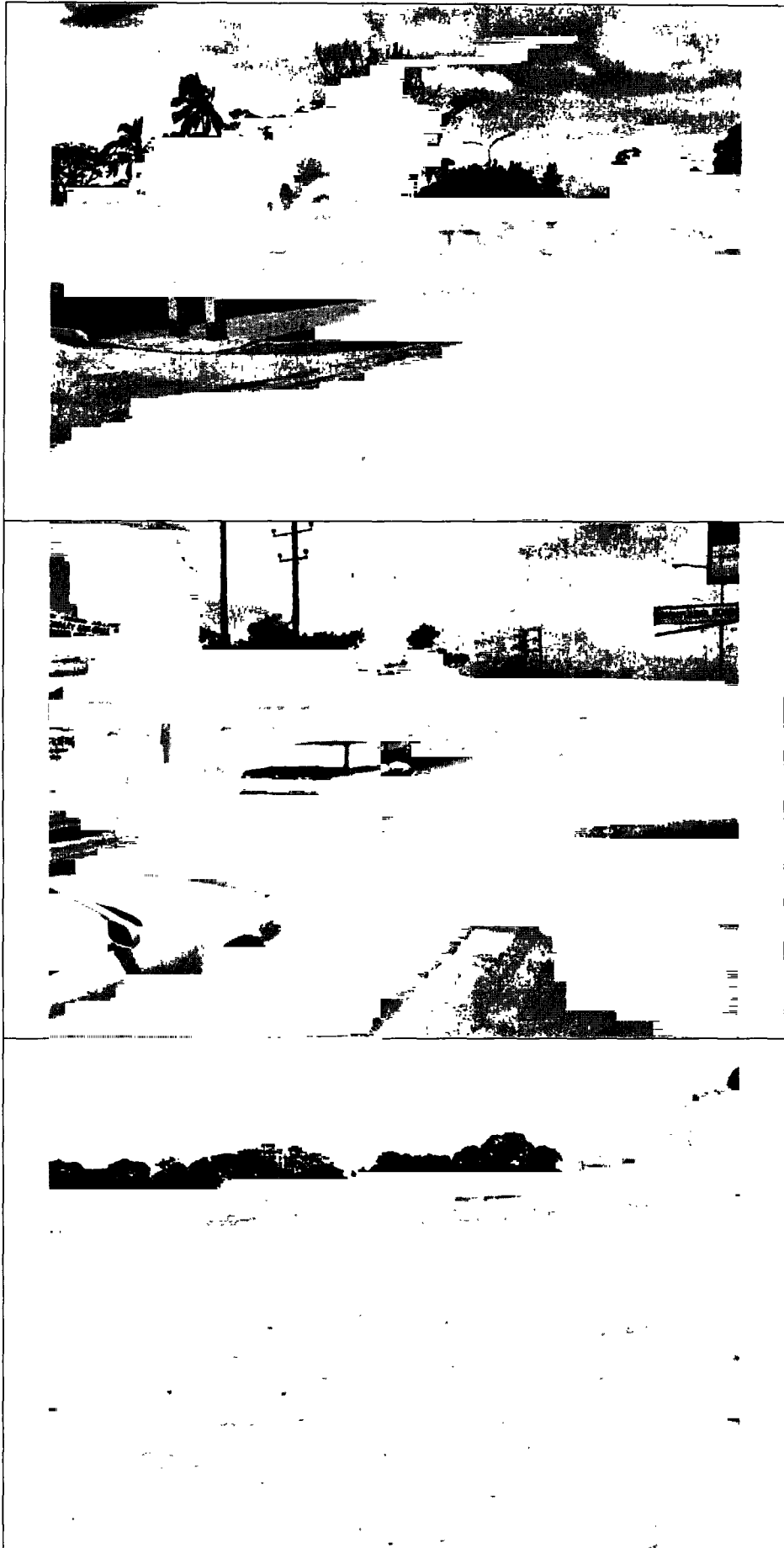

DART – Dar es Salaam Rapid Transit

Environmental and Social Impact Assessment

Land Use Photographic Report

Comments:

Figure 19: Kawawa Rd – Daladala Terminal

Figure 20 – Kawawa Road

Figure 21 – Kaiakoo – Open Space

Date: February/2007
8/9

**DART – Dar es Salaam Rapid
Transit**

**Environmental and Social
Impact Assessment**

**Land Use Photographic
Report**

Comments:

Figure 22: Msimbazi Street, near the
Railway line

Figure 23 – Msimbazi Street – Petrol
Station

Figure 24 – Msimbazi Street

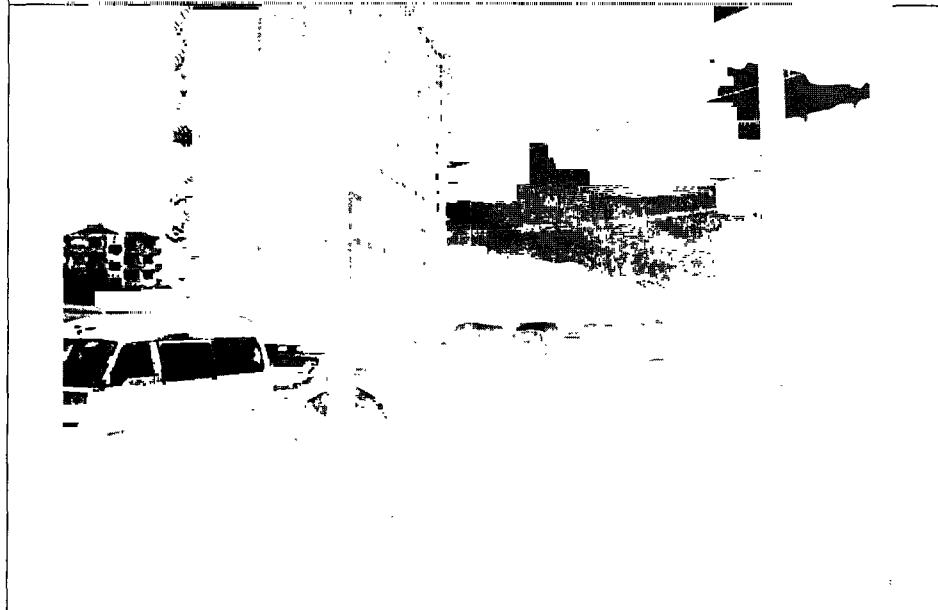
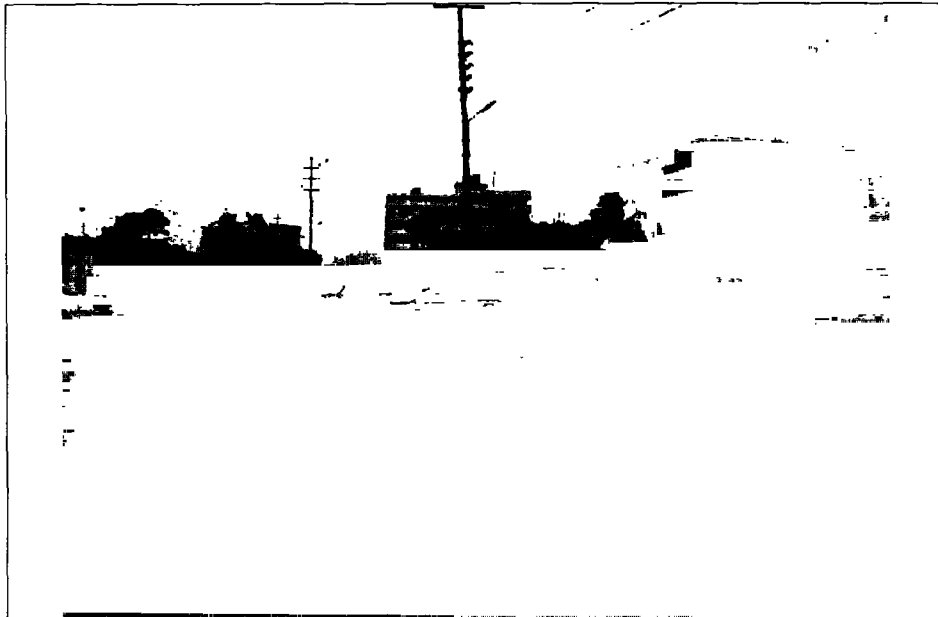

Date: February/2007
9/9

c



**Integrated Dar Es Salaam BRT System
Phase I**

Annex 10 - Traffic Management During Construction

I N D E X

1.0 Sokoine Drive and Kivukoni Front

- 1.1 City Council Station
- 1.2 Morogoro Road from City Council to Bibi Titi
- 1.3 Morogoro Road from Bibi Titi Road to United Nations
- 1.4 Morogoro Road from United Nations To Ubungo
- 1.5 Intersection Morogoro Rd x Bibi Titi Rd
- 1.6 Intersection Morogoro Rd x Lumumba St
- 1.7 Intersection Morogoro Rd x Msimbazi St
- 1.8 Intersection Morogoro x United Nations
- 1.9 Intersection Morogoro x Jangwani
- 1.10 Magomeni Mapipa U Turn Intersection
- 1.11 Morogoro Road x Kawawa Road Intersection
- 1.12 Bakheresa U Turn Intersection
- 1.13 Mabibo Entrance Intersection
- 1.14 Shekilango Road Intersection
- 1.15 Morogoro x Sam Nujoma/Mandela Intersection

For road infrastructure construction proposed for DART system, there will be no traffic diversion during construction. There are no alternative roads that could be used to close parts of Morogoro Road, thus the construction strategy needs to be attached to this reality.

The diversion of traffic will be done on the right of way of the road construction setting the restrictions on the strategy for construction. Except for the downtown stretch of Morogoro Road, where the traffic diversion is necessary as all the road needs to be closed for construction. Since the road will be closed to general traffic in the future, the diversion will be necessary anyway.

The general recommended strategy is to build the extra space and keep moving traffic to the available space as construction advances.

The traffic management in the center will be implemented right at the beginning to liberate space for constructing Morogoro Road (from City Council to Bibi Titi), Sokoine Drive and Kivukoni Front.

The flexible pavement will be constructed till the base, leaving the top finishing to the end. Rigid pavement will be completed at once. It is assumed that the construction companies will attack extensions of two stations at each time.

It is important to enforce in the constructor the application of safety measures as well as environmental protection programs based on the impacts depicted and identified in the Environmental Assessment Analysis work done for the project implementation.

The general solution for traffic management is to construct the new lanes without diverting the general traffic from present lanes, and, when this part is finished, divert it again to the newly built lanes, in order to build the other, and finish the whole stretch. The schemes for each segment and intersection are described in the figures below.

**1.0
Sokoine Drive and Kivukoni Front**

**Figure 1.0.a
Traffic Management on Kivukoni Front**

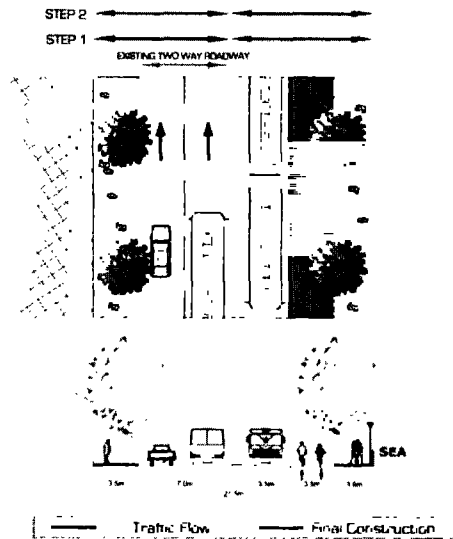

**1.1
City Council Station**

City Council station will not represent any problem as it is outside the road. Anyway, some concern needs to be done if there is going to be an integrated development at this place.

Figure 1.1.a
City Council Station

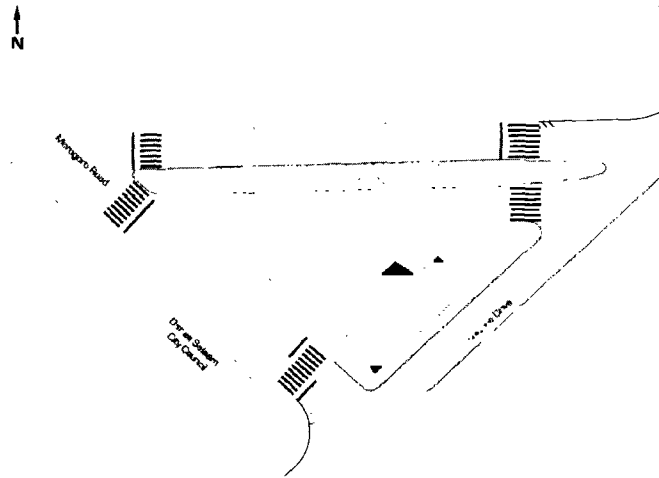

1.2
Morogoro Road from City Council to Bibi Titi

Figure 1.2.a
Morogoro Road along CBD

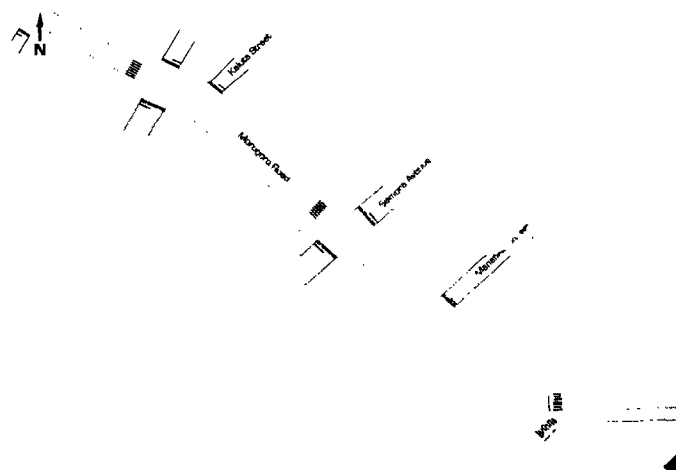

1.3 Morogoro Road from Bibi Titi Road to United Nations

Figure 1.3.a
Traffic Management – Morogoro Road – Bibi Titi to United Nations

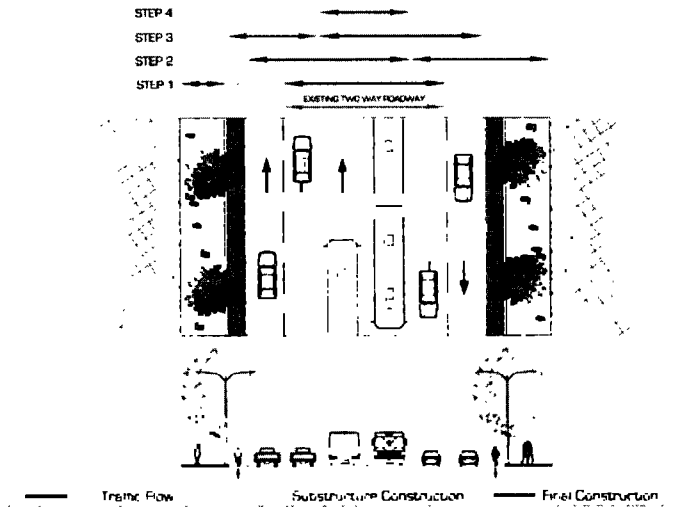

1.4 Morogoro Road from United Nations To Ubungo

Figure 1.4.a
Traffic Management – Morogoro Road- United Nations to Ubungo

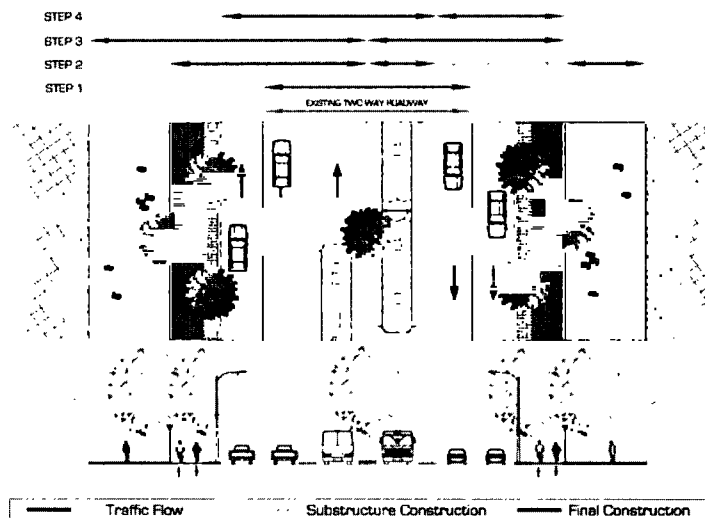

1.5
Intersection Morogoro Rd x Bibi Titi Rd

Figure 1.5.a
Bibi Titi Road Intersection

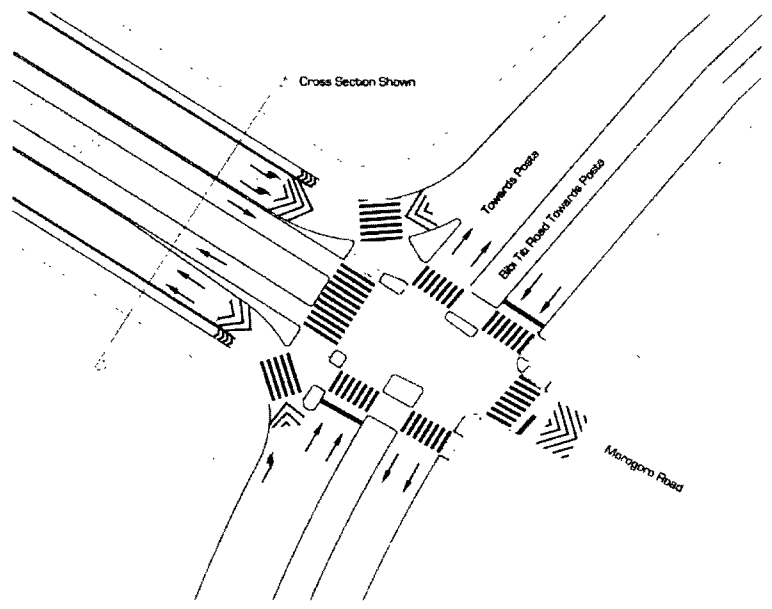
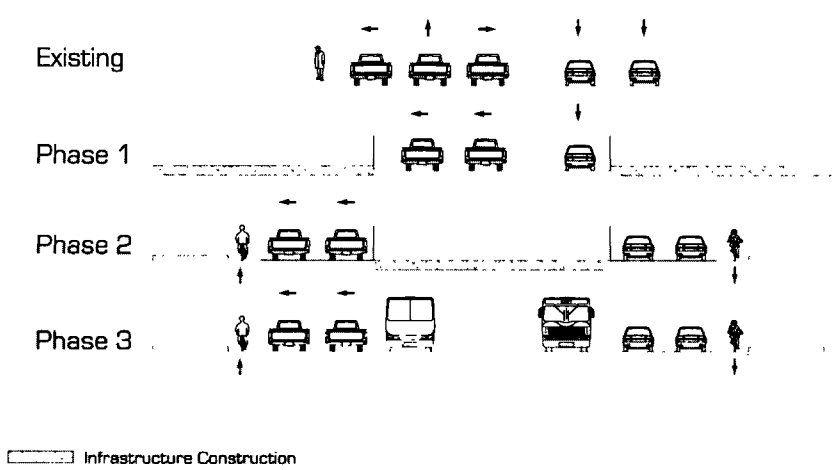

Figure 1.5.b
Bibi Titi Road Intersection / Morogoro Road Construction Phases

MOROGORO ROAD BIBI TITI ROAD JUNCTION
 Intersection cross section view along Morogoro Rd



**1.6
Intersection Morogoro Rd x Lumumba St**

**Figure 1.6.a
Lumumba Street Intersection**

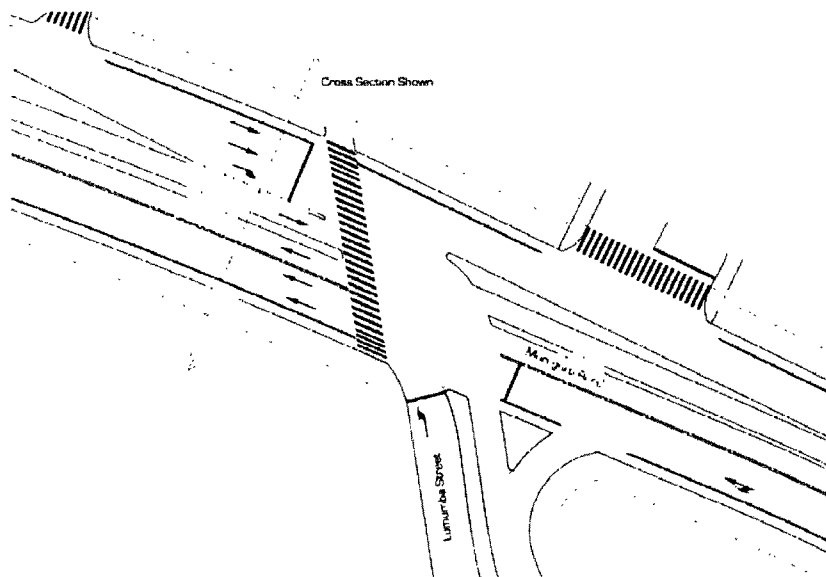

**Figure 1.6.b
Lumumba Street Intersection / Morogoro Road Construction Phases**

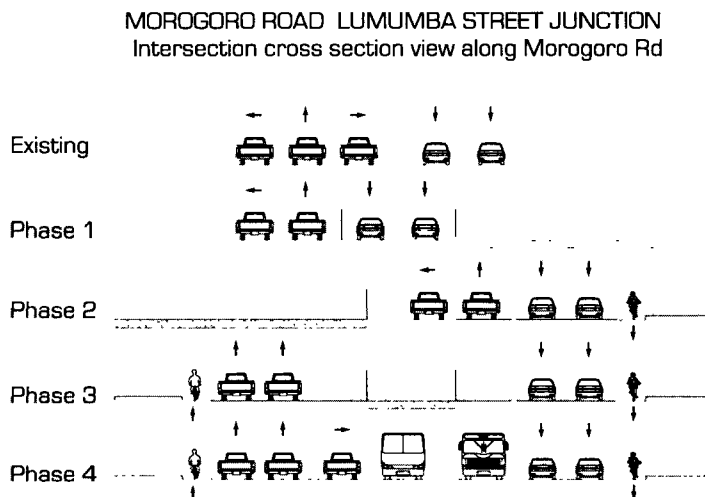

1.7
Intersection Morogoro Rd x Msimbazi St

Figure 2.7.a
Msimbazi Street Intersection

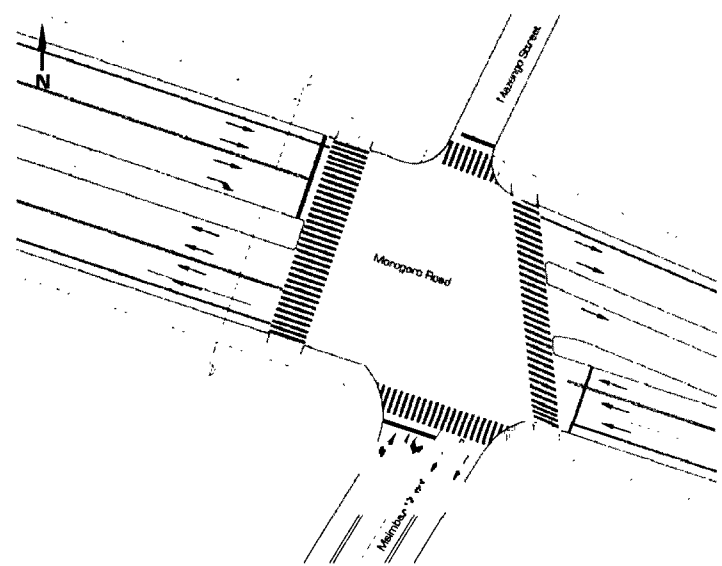
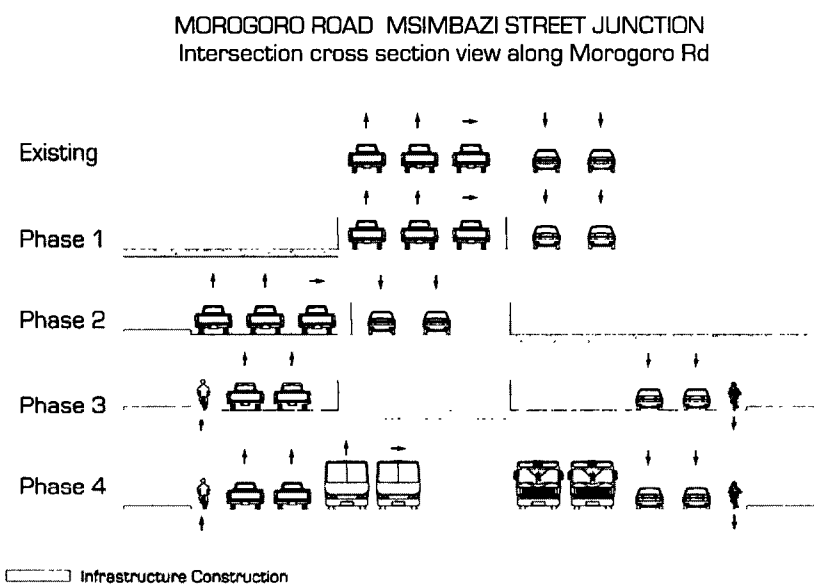
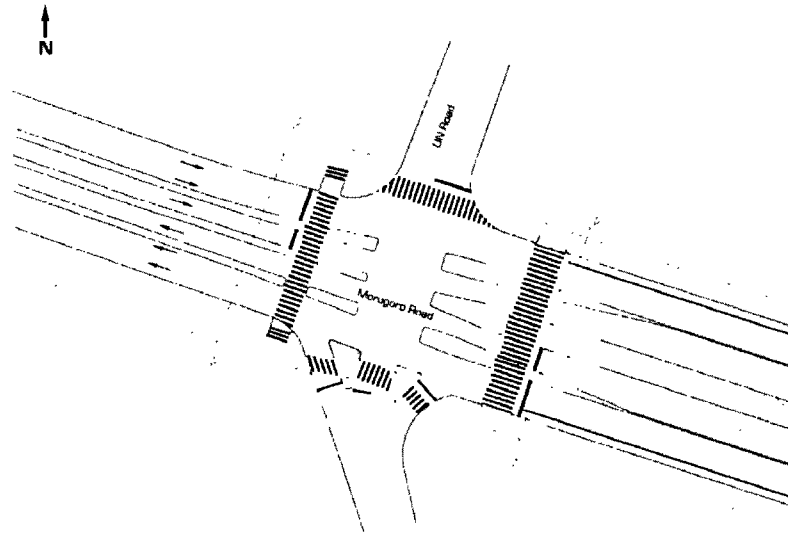

Figure 3.7.b
Msimbazi Street Intersection / Morogoro Road Construction Phases



1.8
Intersection Morogoro x United Nations

**Figure 4.8.a
 United Nations Road Intersection**



**Figure 5.8.b
 United Nations Road Intersection East / Morogoro Road Construction Phases**

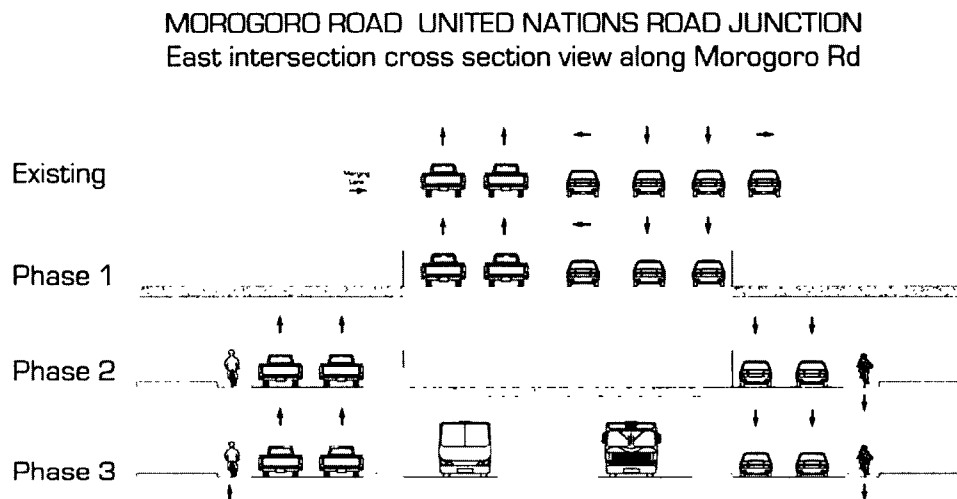
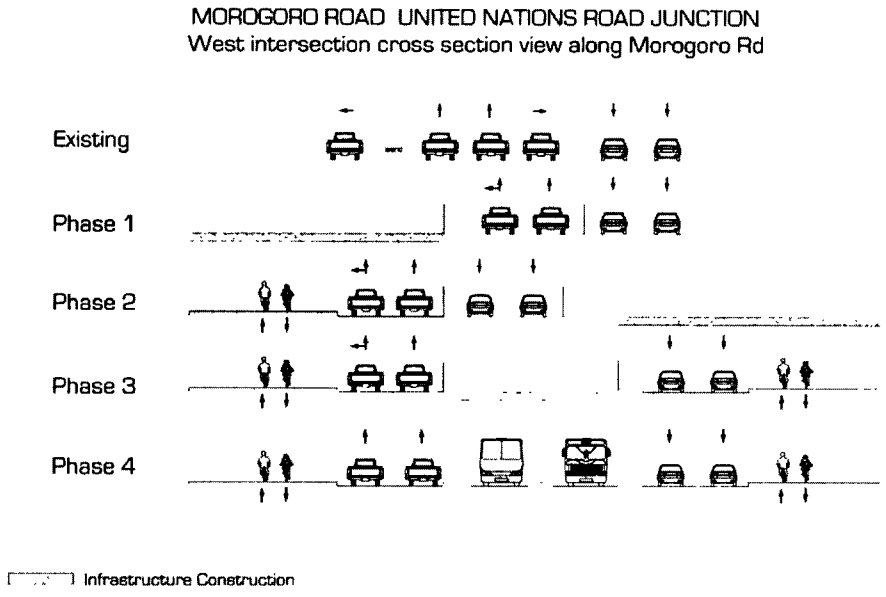

Figure 6.8.c
United Nations Road Intersection West / Morogoro Road Construction Phases



1.9
Intersection Morogoro x Jangwani

Figure 7.9.a
Jangwani Entrance Intersection

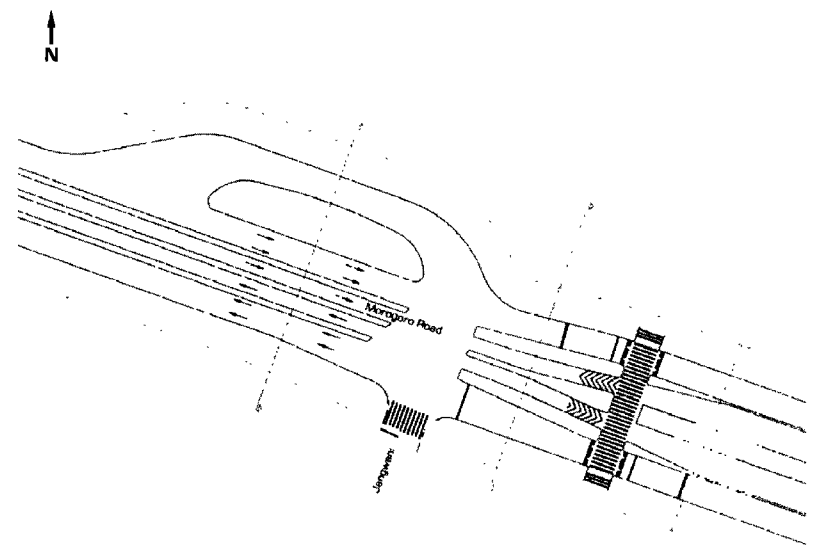
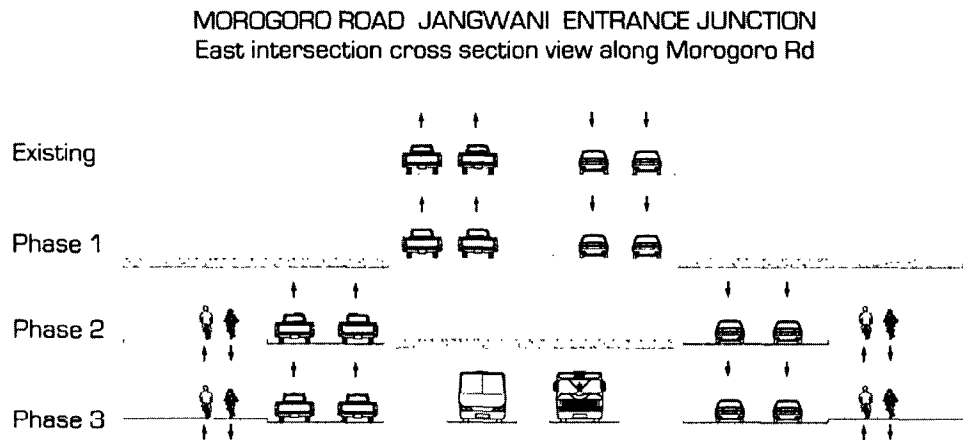
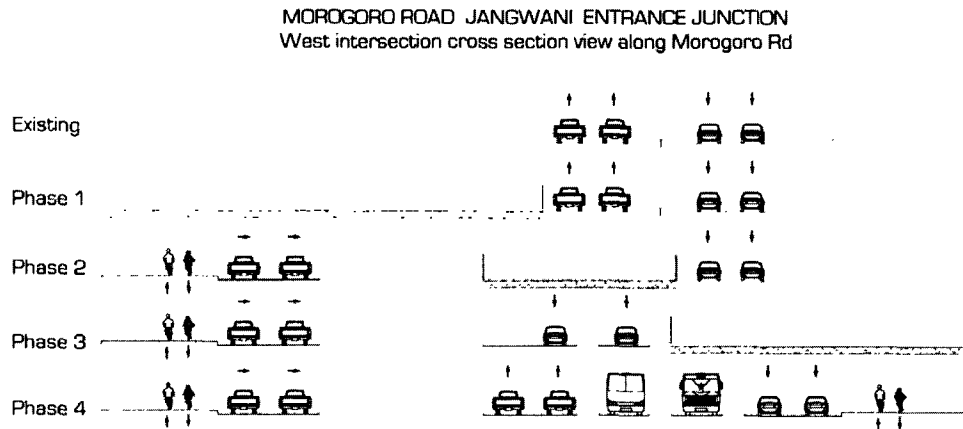

Figure 8.9.b
Jangwani entrance Intersection East / Morogoro Road Construction Phases



Infrastructure Construction

Figure 9.9.c
Jangwani entrance Intersection West / Morogoro Road Construction Phases



Infrastructure Construction

1.10
Magomeni Mapipa U Turn Intersection

Figure 10.10.a
Magomeni Mapipa U Turn Intersection

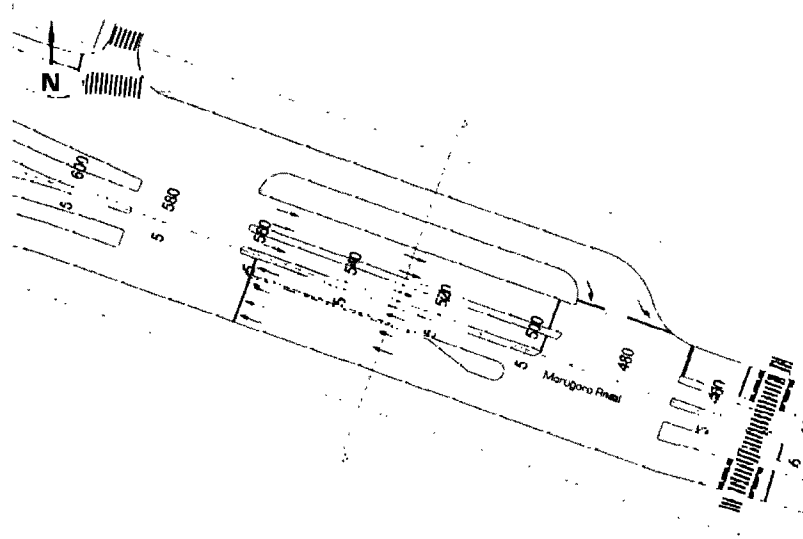
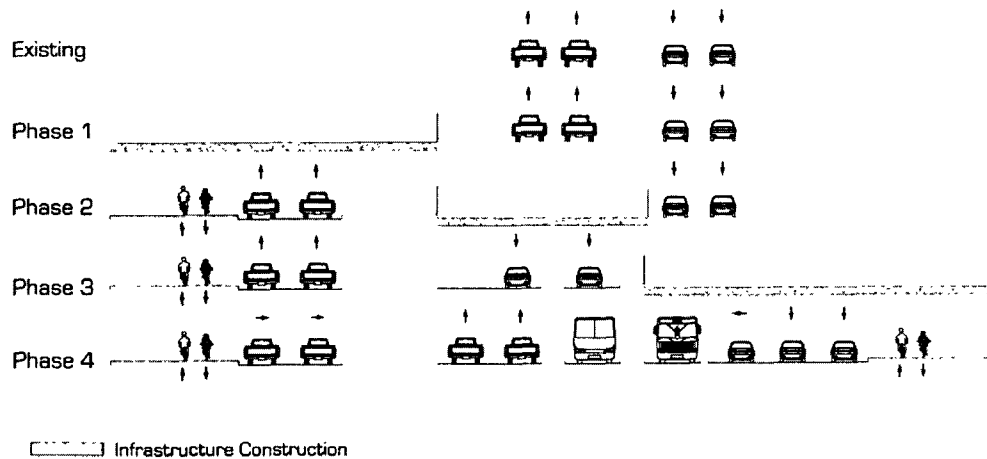

Figure 11.10.b
U Turn Intersection at Magomeni Mapipa/ Morogoro Road Construction Phases

MOROGORO ROAD MAGOMENI MAPIPA U TURN JUNCTION
Intersection cross section view along Morogoro Rd



**1.11
Morogoro Road x Kawawa Road Intersection**

**Figure 1.11.a
Kawawa Road Intersection**

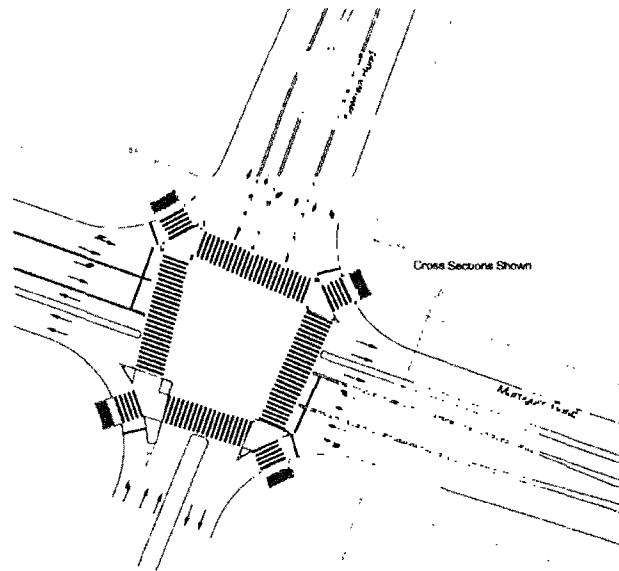

**Figure 12.11.b
Kawawa Intersection / Kawawa Road Construction Phases**

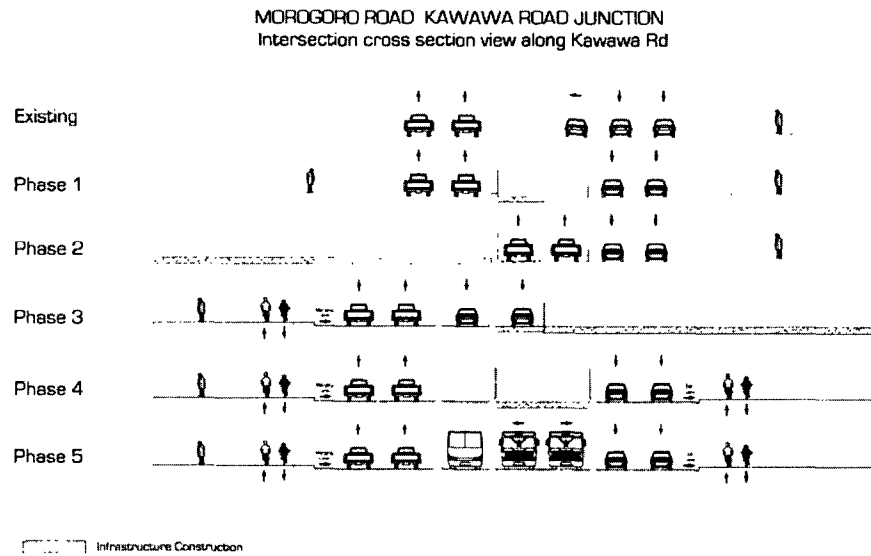
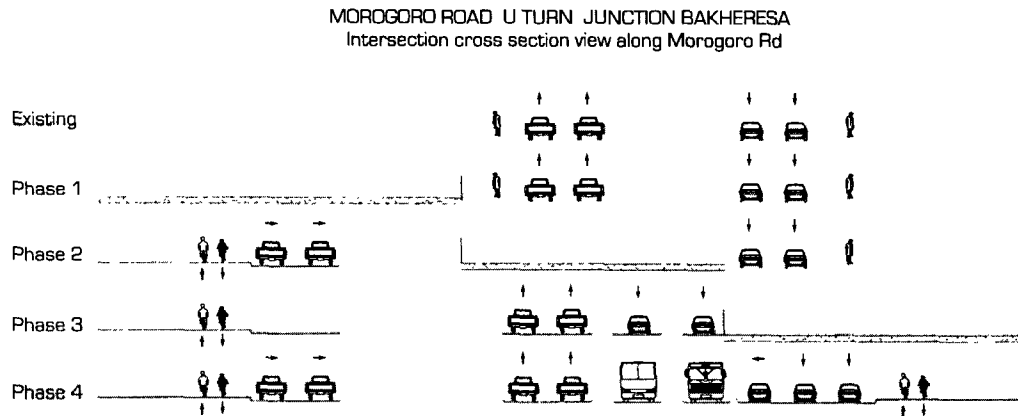

Figure 1.12.b
U Turn Intersection at Bakheresa/ Morogoro Road Construction Phases



[---] Infrastructure Construction

1.13
Mabibo Entrance Intersection

Figure 1.13.a
Mabibo Entrance Intersection

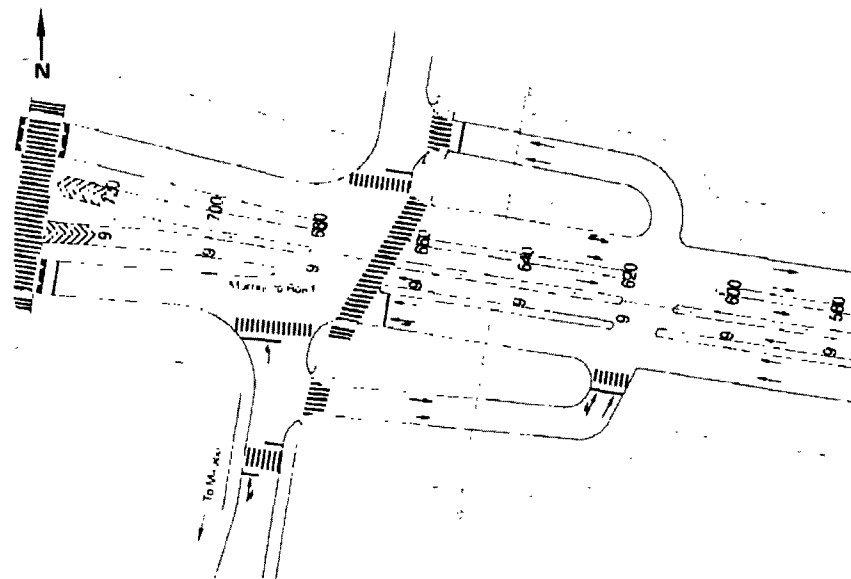
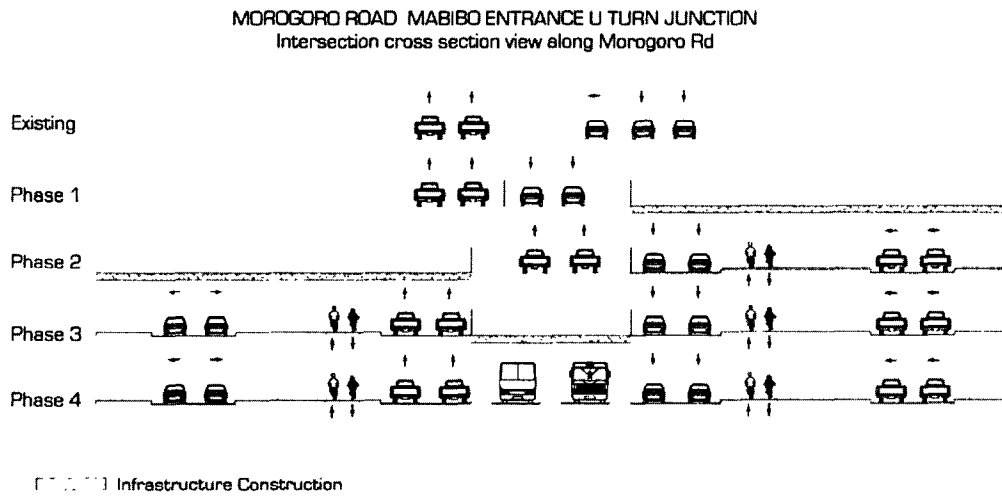

Figure 1.13.b
U Turn Mabibo Entrance/ Morogoro Road Construction Phases



1.14
Shekilango Road Intersection

Figure 1.14.a
Shekilango Road Intersection

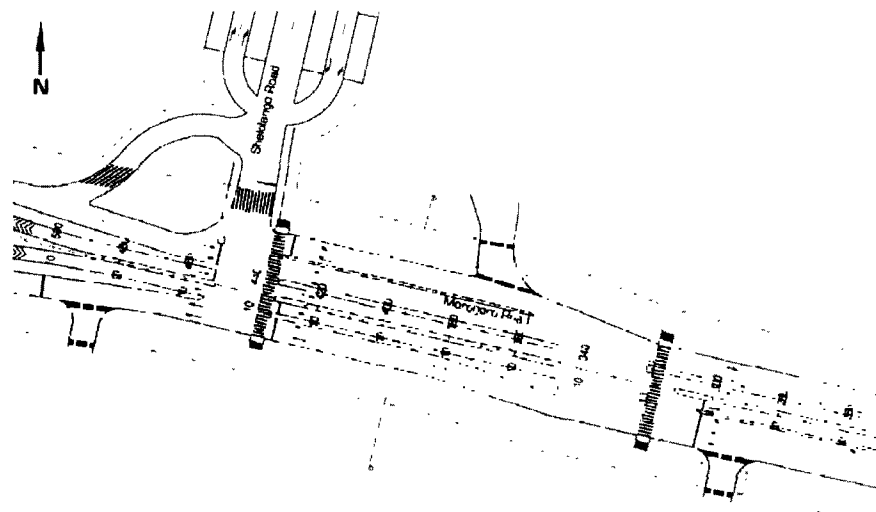
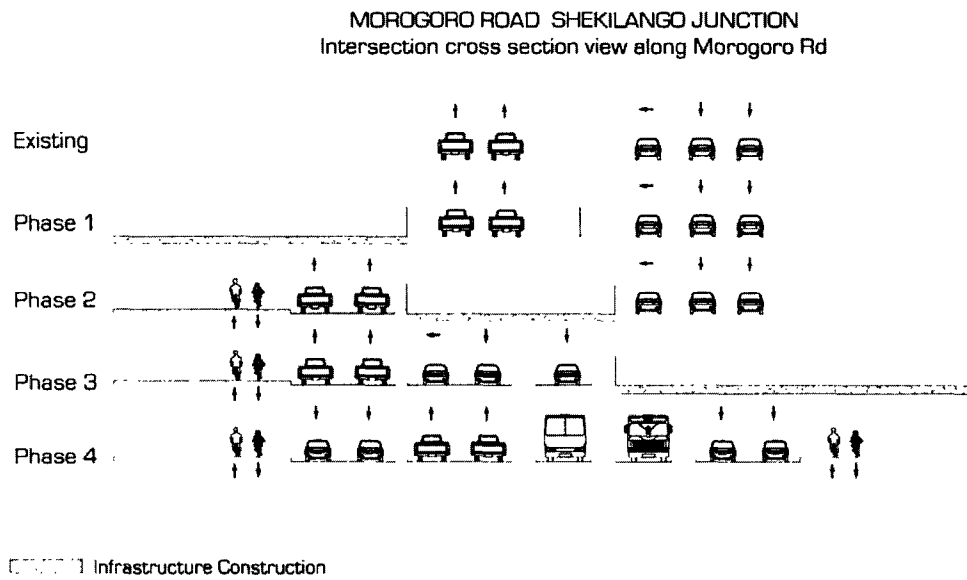

Figure 1.14.b
Shekilango Road/ Morogoro Road Construction Phases



1.15
Morogoro x Sam Nujoma/Mandela Intersection

Figure 1.15.a
Sam Nujoma/Mandela Intersection

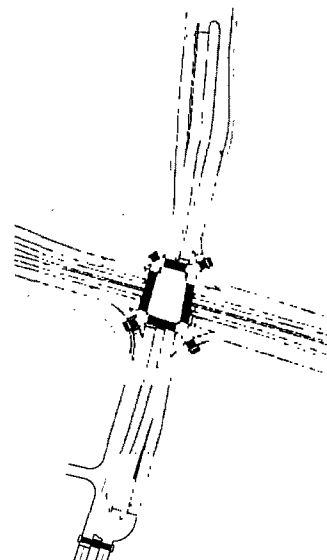

Figure 1.15.b
Morogoro Road Traffic Management/Mandela Intersection Construction Phases

