

E169

Vol 3

---

**ENVIRONMENTAL IMPACT STUDY FOR  
BOLIVIA-BRAZIL GAS PIPELINE PROJECT  
(BOLIVIAN PORTION)**

**FINAL REPORT**

**PREPARED FOR:  
YPFB, ENRON CORP., PETROBRAS & BTB  
AUGUST 30, 1996**

---

 **DAMES & MOORE**

**COCHABAMBA, BOLIVIA**

## EXECUTIVE SUMMARY

### TABLE OF CONTENTS

1.0 INTRODUCTION & BACKGROUND .....	ES - 1
2.0 REGULATORY FRAMEWORK .....	ES - 2
3.0 PROJECT DESCRIPTION .....	ES - 3
3.1 GENERAL .....	ES - 3
3.2 ANALYSIS OF ALTERNATIVES .....	ES - 4
3.3 PROJECT IMPLEMENTATION .....	ES - 5
4.0 ENVIRONMENTAL BASELINE CONDITIONS .....	ES - 6
4.1 AREA OF INFLUENCE/LIFE ZONES .....	ES - 6
4.2 PHYSICAL ENVIRONMENT .....	ES - 6
4.3 BIOLOGICAL ENVIRONMENT .....	ES - 8
5.0 SOCIOECONOMIC BASELINE .....	ES - 9
6.0 ENVIRONMENTAL IMPACTS .....	ES - 10
6.1 GENERAL .....	ES - 10
6.2 IMPACTS ON THE PHYSICAL ENVIRONMENT .....	ES - 12
6.2.1 Air Quality .....	ES - 12
6.2.2 Geology, Geomorphology, and Soils .....	ES - 12
6.2.3 Water Resources .....	ES - 13
6.3 IMPACTS ON THE BIOLOGICAL ENVIRONMENT .....	ES - 14
6.4 IMPACTS ON THE SOCIOECONOMIC ENVIRONMENT .....	ES - 15
6.4.1 Land Use .....	ES - 15
6.4.2 Social Impacts .....	ES - 16
6.4.3 Economic Impacts .....	ES - 17
7.0 ENVIRONMENTAL MANAGEMENT PLAN .....	ES - 19
8.0 PUBLIC CONSULTATION PROGRAM .....	ES - 19
9.0 CONCLUSIONS AND RECOMMENDATIONS .....	ES - 21

## EXECUTIVE SUMMARY

### LIST OF TABLES

<u>TABLE NO.</u>	<u>DESCRIPTION</u>
ES-1	SUMMARY OF IMPACTS AND MITIGATION MEASURES FOR THE BOLIVIA-BRAZIL GAS PIPELINE PROJECT (BOLIVIAN PORTION)
ES-2	SUMMARY OF ESTIMATED COSTS ASSOCIATED WITH THE IMPLEMENTATION OF THE ENVIRONMENTAL MANAGEMENT PROGRAM

# EXECUTIVE SUMMARY

## 1.0 INTRODUCTION & BACKGROUND

This document presents an updated Environmental Impact Study (EIS) completed by Dames & Moore for the Bolivian portion of the proposed Bolivia to Brazil Natural Gas Transmission Pipeline. This study was completed in accordance with the requirements established in the Professional Services Agreement No. PSA-02-95 signed between Enron Power Corporation (Enron) and Dames & Moore, Inc. The primary work associated with the EIS was completed during the period of December, 1995 to June, 1996.

The purpose of the proposed pipeline project addressed in this study is to transport and sell the natural gas developed in central Bolivia to major industrial centers of Brazil in response to their growing demand for energy. The project is being developed by YPFB and Petrobras, together with participating partners Enron Corporation in the Bolivian sector and the BTB Group in the Brazilian sector. The BTB Group represents a consortium comprised of Broken Hill Proprietary Company Limited (BHP), Tenneco Energy, and British Gas. The majority equity interest in the project is held by YPFB and Petrobras.

Prior to Dames & Moore's involvement in the project, a previous Environmental Impact Study (Original Assessment) was completed in 1990 by a Bolivian consultant, the *Centro de Investigaciones y Estudio de la Capacidad de Uso Mayor de la Tierra* (CUMAT). The results of the previous study were presented in a report entitled "Environmental Impact Assessment for the Construction of the Gas Pipeline and Puerto Suárez Steam-Electric Power Plant" and dated September, 1990.

The updated EIS has been prepared to identify and address current issues related to project facilities to be located and operated in Bolivia, to support applications from the Project Sponsors to international financing institutions for project funding, and to comply with the requirements of the new Bolivian Environmental Law. Separate environmental documents are being prepared by a Brazilian Consultant to identify and address issues related to the project facilities to be located and operated in Brazil.



The EIS was based on a comprehensive review of existing information, field work, and community workshops which were completed to evaluate the biophysical and socioeconomic environments in the area of influence of the project. Technical and environmental concepts were integrated in the analysis to ensure that the pipeline is constructed, operated, and managed in accordance with the conditions presented by the project's natural and social surroundings. Efforts were directed at maximizing the project's benefits in the area of influence, while preventing and mitigating its potential negative effects.

The key chapters of the EIS are reviewed and discussed below.

## **2.0 REGULATORY FRAMEWORK**

The Bolivian legislation and international guidelines reviewed as part of this study included the following:

- Bolivian Environmental Law No. 1333,
- Bolivian Hydrocarbon Law No. 1689,
- Proposed Bolivian Law of Indigenous Settlements in Eastern Bolivia, the Chaco, and the Amazons (proposed by Supreme Decree No. 22612 of October 10, 1990),
- Proposed Bolivian Law of Conservation of Biological Diversity (proposed by the Bolivian Senate on October 14, 1992),
- Legal Regulations related to Bolivian Archeological Heritage.
- Bolivian Supreme Decree No. 24122 of September 21, 1995, giving protection status to over 3.4 million hectares of land and establishing the Grand Chaco National Park and its Integrated Land Use Areas.
- World Bank/IFC Environmental Guidelines and Policies.

Ministerial Resolution No. 259-91, dated September 20, 1991, approved the previous Environmental Impact Study (EIS) of March 1990 completed by CUMAT for the Bolivia-Brazil Gas Pipeline Project and the Puerto Suárez Thermoelectric Plant. The Ministerial Resolution does not refer to a validity period for the license. Because the scope of the project has changed since the approval of the original environmental license, the license will be amended. In an effort to

expedite the review and amendment process, a renewal request will be filed by the Project Sponsors along with a copy of the updated EIS. Under the new Environmental Law in Bolivia, if a project does not commence activity within a period of 12 months from issuance of the license, the license must be renewed.

### **3.0 PROJECT DESCRIPTION**

#### **3.1 GENERAL**

Bolivia is a gas-producing country with a significant surplus of natural gas in relation to its internal consumption, while Brazil has a shortage of energy supply. In 1988, the presidents of Bolivia and Brazil signed an Energy Integration Treaty in which Brazil committed to buy electric power generated with natural gas from a thermal plant to be constructed at the border between both countries. In 1993, a gas supply agreement was signed by YPFB and Petrobras, which established a contractual obligation for supply and purchase of natural gas.

The Bolivia-Brazil gas pipeline will extend approximately 3,100 kilometers from YPFB's Río Grande Natural Gas Plant located approximately 40 kilometers southeast of the city of Santa Cruz de la Sierra, Bolivia, through São Paulo, turning south and terminating near the city of Porto Alegre in Brazil. The approximately 555 kilometer Bolivian sector of the transmission system will follow a relatively straight line, running in a west to east direction. The pipeline will cross the predominantly flat tropical dry forest of the Bolivian Chaco region within the Department of Santa Cruz, in the southeastern portion of Bolivia. The right-of-way will run parallel to and south of an existing railway from a point approximately 40 kilometers west of the town of El Carmen, then in a southeast direction to the town of El Carmen de la Frontera, on the Bolivia-Brazil border. East of the Otuquis river, the gas pipeline will cross the northern portion of the Otuquis and Tacuaral marshes.

The pipe required for the Bolivian sector will be 32-inch diameter, 0.406-0.649 inch wall thickness, manufactured in accordance with API-5L, X-70 standards. The pipeline will be

designed for a maximum allowable operating pressure of 1,420 psi. Automatic reduced pressure shutdown valves will be installed to ensure safety of the line. Pig launchers and receivers will be installed for the purpose of internal inspection and cleaning of the pipe.

Four compressor stations will be included in the system design for the Bolivian sector. One station will be installed near the town of Yacuces in the first phase of the project, and the remaining three will be constructed as required to increase delivery volumes and maintain acceptable pipeline pressure. There will be two metering stations in Bolivia. The first station will be located at the Río Grande Gas Plant to measure the volumes of gas entering the pipeline owned by the Bolivian Transportation Company. The second station will be at the Bolivia-Brazil border to measure the gas for custody transfer to the Brazilian Transportation Company.

The installation of a fiber optic cable will be included within the scope of the project. The cable may either be placed in the same ditch as the pipeline or in a separate ditch within the pipeline right-of-way.

The pipe will likely be imported to Bolivia through the Port of Rosario in Argentina, which will be the receiving port for ocean freight. From the Port of Rosario, pipe will be transported to the Port of Aguirre on the Bolivia-Brazil border, then by train to designated storage yards in Bolivia. From the storage yards, pipe will be transported by truck to the right-of-way for stringing. Other possibilities include, 1) receiving the pipe through the port in Arica, Chile, transporting by truck to Santa Cruz, then to the storage yards by railway, or 2) receiving the pipe through the port in Buenos Aires, Argentina, transporting via the Belgrano Railway to Santa Cruz, then to storage sites by rail.

### 3.2 ANALYSIS OF ALTERNATIVES

The majority of the proposed route for the Bolivian portion of the Bolivia-Brazil Gas Pipeline was selected based on the study performed by CUMAT (1990). The following were among the alternatives identified and considered:

*No-Project.* The alternative of not executing the project was included.

*Alternative No.1.* The pipeline would run parallel to the existing railroad between Pailón and Puerto Suárez. Under this alternative, the Bolivian portion of the pipeline would run adjacent to or through several populated centers such as Pailón, San José de Chiquitos, Roboré, El Carmen, and Puerto Suárez.

*Alternative No.2 (Proposed).* The proposed alternative follows a relatively straight route from the Río Grande Gas Plant to Puerto Suárez, across the Bolivian Chaco region. Portions of this route mark the northern border of the Parque Nacional Gran Chaco. Other components of the project, such as the number of camps, compressor stations, and meter stations would be similar in alternatives 1 and 2.

In the CUMAT study, the results of the environmental evaluation of the two corridors are summarized as follows:

- Alternative No. 2 was preferred from an environmental perspective, mainly because it traverses relatively homogeneous terrain.
- Alternative No. 1 would run close to populated areas and along the few areas under active agricultural uses within the study area.
- Project costs were estimated to be lower for Alternative 2 attributable to the less difficult construction conditions and the shorter distance of construction.

Therefore, the proposed route (Alternative No. 2) for the gas pipeline was determined to best balance overall impacts to the human, biological, and physical environment while achieving its overall purpose.

### **3.3 PROJECT IMPLEMENTATION**

The construction phase of the project is not expected to occur until 1997. Mobilization of construction contractor personnel is scheduled for June, 1997 and demobilization is planned for July 1998. Detail design and right-of-way acquisition will be the first activities to be initiated.

The proposed right-of-way will be thirty (30) meters in width, including both the temporary work space and the seventeen (17) meter permanent right-of-way. The pipeline will be installed approximately one meter below grade. Installation of a fiber optic cable, if included in the project scope, will be within the pipeline trench or in a separate ditch within the same right-of way. Compressor stations, metering stations and line valve operators will be installed above ground. Storage yards, construction camps, and temporary work spaces will be restored and allowed to revegetate and return to a natural state. Access roads and permanent right-of-way will be maintained to service the facilities to be constructed.

## **4.0 ENVIRONMENTAL BASELINE CONDITIONS**

### **4.1 AREA OF INFLUENCE/LIFE ZONES**

For this study, the area of influence of the project was defined as the area included within imaginary lines located 10 km to the north of the Santa Cruz to Puerto Suárez railroad and 10 km to the south of the proposed pipeline alignment. The study area incorporates both the proposed pipeline route and the main route alternative considered for the project, parallel to the railroad. The railroad corridor will also provide the main route for the transport of supplies for the project and is thus considered part of the project area.

Three life zones occur within the study area: Temperate Thorny Scrub, Temperate Dry Forest, and Temperate Humid Forest.

### **4.2 PHYSICAL ENVIRONMENT**

The entire area of influence of the project is within the Steppe Climate zone according to the Köppen classification system. In the study area, average annual temperature shows a very slight increase from west to east, ranging from 24 to 26°C throughout the study area. The distribution of average rainfall follows a similar pattern, varying from about 700 mm/yr in the southwestern portion of the study area to more than 1000 mm/yr in the east.

The study area lies on the drainage divide between the Amazon basin to the north and the Paraguay basin to the south. The proposed pipeline route lies within the Llanura Chaqueña, which is generally very flat, with very little relief, except where the plain is cut by occasional small streams and creeks. Significant rivers which cut the Llanura Chaqueña include the Río Grande and the Río Parapetí, which drain the western portion of the region and flow northward to the Amazon Basin; the southward flowing Río San Miguel, which drains the central portion of the region; and the eastward flowing Ríos San Rafael/Aguas Calientes, Tucavaca, and Otuquis, which drain the Sierras Chiquitanas in the eastern portion of the region, draining south and east to the Río Paraguay. The proposed route also traverses three large wetland regions; the Bañados de Izozog, associated with the Río Parapetí; the Bañados de Otuquis, associated with the Río Otuquis; and the Cañón de la Victoria, an intermittent connection between two distinct wetland systems, the Bañados de Otuquis in Bolivia and the Pantanal system in Brazil.

**Physiographic Setting.** The proposed pipeline route lies entirely within the Llanura (Plains) physiographic province. This region consists of a broad flat plain of very low relief, varying in width from about 200 to 700 km, which extends from the Sub Andean foothills on the west to the Bolivian/Brazilian border on the east.

**Geologic Setting.** The Llanura physiographic province is a broad, northwest-southeast trending trough which is bounded on the northeast and southwest by relatively elevated portions of the Brazilian Shield and the Faja Subandina, respectively. The surface of the Llanura is characterized by a nearly complete cover of quaternary aged sediments. These consist of varying thicknesses of generally fine grained sediments (clay, silt, and fine sand with lesser amounts of medium to coarse sand and gravel), which were deposited by alluvial, fluvio-lacustrine, coluvial and eolian processes.

**Bedrock Units.** Available information indicates that the stratigraphic column in the study area includes bedrock units ranging in age from Precambrian to Tertiary.

**Soils.** Soils present in the study area are classified into four major groups as follows:

- Alluvial and eolian plains soils, which occur mainly in the western third of the project.

- Soils developed directly on exposed sedimentary bedrock units of Cretaceous to Carboniferous age, which occur mainly in the central portion of the study area.
- Mountain soils, present mainly in the area of the Sierras Chiquitanas and in isolated hilly areas, most of which are concentrated in the eastern portion of the study area.
- Soils developed on crystalline Precambrian aged rocks of the Escudo Chiquitano (exposed Precambrian basement rocks along the Bolivian/Brazilian border).

**Land Use.** Current land uses respond to six land capacity classes found in the study area. Most of the study area is under natural vegetation cover, with small areas under agricultural and extensive cattle ranching uses, and scattered human concentrations.

#### 4.3 BIOLOGICAL ENVIRONMENT

Various types of vegetation cover are present throughout the study area, particularly since the area is a transition zone between the biogeographic regions of the Cerrado and the Amazon to the north, and the Chaqueña region to the south and the Andes to the west. The three key types are: Temperate Thorny Scrub, Temperate Dry Forest and Temperate Humid Forest.

Fauna have been described according to the three different life zones described above. Typical fauna found in the project area are:

- A. Mammals. The most pursued and threatened species in this group include large mammals such as deer, wild pigs, and large cats that are hunted for their meat and skin. The group of felines is hunted indiscriminately because they are considered a threat to the cattle which occupy a broad area of the woodland.
- B. Avifauna. The group of birds in this life zone have an Andean-Patagonian influence in the south and east and also represent the dispersal limits of some Amazonian avifauna. The most common of these include parrots, toucans and wading birds.
- C. Reptiles. The most important reptile species include the tortoise *Geochelone chilensis* (Peta), *Geochelone carbonaria* (Peta), *Tupinambis tequixín* (Peni o iguana), and poisonous

snakes such as *Lachesis muta muta* (Pucarara), and *Botrops atrox* (Yope). In the Pantanal area, the caiman *Caiman yacare* (Yacare), is intensively pursued on the Bolivian side, as hunting restrictions are non-existent.

The study area was classified into three categories of environmental sensitivity which reflect how susceptible the environment is to the anticipated effects of the project. The classification resulted in the following partition of the study area:

- *High Environmental Sensitivity.* The area of the Gran Chaco National Park and the adjacent Bañados de Izozog are highly sensitive to the project. Biogeographically, this area represents the interface between the Amazon, the Andes, and the Patagonian regions. Furthermore, this area also harbors indigenous people.
- *Medium Environmental Sensitivity.* This category includes the foothills of the Sierras Chiquitanas (areas of potential slope instability), the savannahs associated with the Río San Miguel (areas of relatively high potential for aeolic erosion); and the floodplain of the Río Grande, which is associated with historical river channel modifications and supports relatively rich soils with agricultural potential.
- *Low Environmental Sensitivity.* Which includes the balance of the study area. These areas are either disturbed by human use or, if under natural vegetation cover, appear as resilient to the types of effects anticipated with the construction of the pipeline.

## 5.0 SOCIOECONOMIC BASELINE

The socioeconomic baseline of the study area was defined by characteristics and attributes of land uses, population, health, education, indigenous peoples; cultural, archeological and recreational resources; productive systems, employment, and infrastructure. The existing database created in the previous EIS completed by CUMAT was reviewed and documented to provide baseline information for use for this study. The existing data were updated and supplemented with readily available information obtained from the 1992 National Census and the 1994-1995 Census of the Indigenous Peoples of Oriente, Chaco and the Amazons. In circumstances where the existing data



were judged insufficient for EIS purposes, the socioeconomic data base was supplemented with information collected during field surveys.

The methodology used for the field work consisted of a combination of qualitative and quantitative data collection techniques such as rapid rural appraisal, community surveys, and formal and informal interviews. The main objective of the field work was to gain a sound understanding of the socioeconomic conditions and use of ecologic resources of the study area, and to assess areas which would be influenced directly and indirectly by the project.

Administratively, the study area corresponds to the Provinces of Chiquitos, Cordillera, and German Busch. The urban settlements within the study area include the towns of Pailón, San José de Chiquitos, Roboré, El Carmen, Puerto Suarez, and Puerto Quijarro. The 1992 census indicated a total of 41,101 inhabitants for the combined population of these six urban centers. Their combined projected population for 1996 is 48,335 inhabitants.

The indigenous groups located within the study area are the Ayoreode, the Chiquitanos, and the Izozeño Guaraní communities. The Ayoreode group has transient economy and semi-nomadic culture, and occupy an enormous physical area in the southern part of what is now the Department of Santa Cruz, and the northern Chaco area of the neighboring country, Paraguay. In contrast to the Ayoreode people, the Chiquitanos have been an essentially sedentary group for more than a century, due to Jesuit activities during colonial times. After a process of mixing and becoming peasants, they cannot be identified easily at first glance. The Izozeño Guaraní group includes 22 communities which constitute *The Capitanía del Alto y Bajo Izozog* (CABI). The CABI community is settled within the Izozog Wetlands (Bañados del Izozog) which is located along the Parapeti River watershed.

## 6.0 ENVIRONMENTAL IMPACTS

### 6.1 GENERAL

The potential impacts on the existing physical, biological, and human environment resulting from the construction, operation, and abandonment of the proposed gas pipeline project are identified

and described in Chapter 6.0. This includes both beneficial and adverse impacts and related significance. Impacts are defined as those changes to the baseline conditions that are a direct or indirect consequence of the project.

Impacts were analyzed using a combination of matrices, modeling, and map overlays developed in a Geographic Information System (GIS). An impact identification matrix was used to determine associations between the project activities and the environmental parameters, based on predicted modifications to the existing environmental conditions as a result of construction and operation of the project. For each possible combination of activity and environmental parameter, an assessment was made as to whether the baseline condition of a given environmental parameter is likely to be modified by the project activity. The GIS-based map overlays were used in the quantification of the impacts on individual environmental parameters such as soils and vegetation.

The following key environmental parameters were identified to evaluate potential impacts of the project: Physical Environment (climate and air quality, geology, geomorphology, and soils, water resources, and noise), Biological Environment (vegetation, fauna, species of special concern, and protected areas), and Socioeconomic Environment (population, economy, indigenous people, and cultural, historical, and archeological resources). Project activities were summarized into the following categories: construction, operations, abandonment.

Impacts were assessed based upon published and unpublished information, field surveys, and analytical procedures. Impacts were classified as Beneficial or Adverse, Direct or Indirect, Significant or Insignificant, Permanent or Temporary, Extended (over a large area) or Localized, Proximal (effect is evident only in the vicinity) or Remote (effect spreads out far away), Reversible or Irreversible, Mitigable (its effects may be minimized, reverted or nullified) or Not Mitigable, and Cumulative or Synergistic.

## **6.2 IMPACTS ON THE PHYSICAL ENVIRONMENT**

### **6.2.1 Air Quality**

The potential air quality impacts identified are associated with the following activities or conditions in the study area:

- Emission sources associated with site grading and road and building construction activities.
- Pollutants related to construction equipment exhaust and welding activities.
- Emissions associated with the operation of the proposed four compressor stations.

During construction, the project would introduce temporary emission sources associated with site grading and road and building construction activities. Such activities would occur along the pipeline right-of-way and at locations of roadway improvements. The primary pollutant emission associated with construction activities would be dust, or particulate matter having a diameter of less than 10 microns ( $PM_{10}$ ), generated from site grading and other earthmoving activities.

During operation of the pipeline, emission sources will be related to the proposed four compressor stations sited on Bolivian territory. The operation of the four compressor stations was screen-modeled using the simulator program SCREEN3. The pollutants evaluated for the operation phase of the project included Nitrogen Oxides ( $NO_x$ ), Carbon Monoxide (CO), and Particulate Matter less than 10 microns in diameter ( $PM_{10}$ ). Impacts predicted using the SCREEN3 model were compared with the current Bolivian National Ambient Air Quality Standards (NAAQS) and World Bank Guidelines for Onshore Oil and Gas Development.

### **6.2.2 Geology, Geomorphology, and Soils**

The potential impacts identified related to geology, soils, and seismicity are associated with the following activities or conditions in the study area: ground disturbance resulting in wind and water erosion, damage to project facilities from differential settlement, localized ground disturbance from blasting, damage to project facilities from geohazards, and increased sediment in receiving waters.

The primary impact of the project on soils is an increase in the erosion potential in areas where soil becomes exposed by vegetation removal and areas where soils are physically disturbed by trenching, spoil piling, and backfilling. Vegetation clearing, particularly in undisturbed forested areas, exposes previously protected soils to changes in surface temperature and to direct rainfall and sunlight, therefore increasing the potential for erosion. However, the project will include drainage and erosion control measures implemented as part of construction. Consequently, erosion would be localized and short-term and would be considered a less-than-significant impact.

The proposed pipeline will cross three major rivers and other minor streams. These crossings will be constructed using open-cut methods which could suspend temporarily sediment in the streams during construction activities. Because open-cut construction of all crossings is planned to take place during periods of low flow to minimize sedimentation and facilitate construction, impacts related to increased sediment loads in rivers and streams will be temporary and localized, and are considered less than significant.

Blasting may be required to remove bedrock exposed during site preparation. However, given the relatively short-term and localized nature of this impact, it is considered to be less than significant.

### **6.2.3 Water Resources**

The potential impacts identified related to hydrology, hydrogeology, and water quality are associated with the following activities or conditions in the study area: changes in base and peak flows of nearby streams and rivers, groundwater withdrawal to support both construction and operation, reduction in groundwater or surface water quality, and increased sediment loads.

The impact of withdrawals from surface waters for hydrotesting of the pipeline is considered less than significant if the withdrawals are made during average flow conditions. The discharge would take place in uplands and would be released at a rate low enough to avoid erosion damage. Appropriate erosion control measures and volume controls will be incorporated. The impact on the local ground surface and soils is considered less than significant.

Major activities during the construction phase of the project will require the use of potable water for workers. Potable water sources for these workers will be withdrawn from wells installed at depths ranging from 100 m to 200 m. The groundwater resources are recharged mainly by infiltration of rainwater and the expected annual recharge is relatively high. Therefore, impacts from groundwater withdrawal to meet the domestic water requirements of the project on the aquifer water balance will not be significant.

Potential impacts to surface water and groundwater quality may result from the mobilization and operation of equipment, fuel and materials storage and transfer operations, equipment maintenance activities, operating accidents and waste disposal. Contaminants released into surface water bodies and/or shallow groundwater aquifers from the above sources could include, but not necessarily be limited to the following: Oil and Grease (lubricants, etc.); Volatile Organic Compounds (VOCs) and Semivolatile Organic Compounds (SVOCs) from fuels, hydraulic fluids, anticorrosives, paint, etc.; Metals (contaminants in used lubricating oils, paints, etc.); Bacterial products from sanitary wastes; and increased Total Dissolved Solids (TDS) and Total Suspended Solids (TSS) from surface runoff from impacted areas. However, sound mitigation measures should minimized potential impacts to surface and groundwater quality.

### **6.3 IMPACTS ON THE BIOLOGICAL ENVIRONMENT**

**Vegetation.** Construction activities, including clearing and grading, trenching, backfilling, hydrostatic testing (during discharge of water), and final cleanup, will cause temporary and permanent alteration of vegetation within the pipeline right-of-way. These activities will also affect medium forest areas (both dry and wet) and a small area of riparian forest associated with the Río Parapetí system. Herbaceous and shrubby vegetation will be temporarily impacted by construction activities. However, in most areas of the pipeline corridor, native herbaceous and shrubby species are expected to revegetate naturally following completion of pipeline construction.

**Fauna.** Potential impacts affecting animal populations generally include the following: direct loss of individuals from construction activities or increased hunting pressure due to new or improved access into a previously remote area; direct loss of important habitat elements such as breeding, foraging, and cover areas; direct disturbance to or loss of wildlife habitat; displacement of

individual animals during construction or maintenance; fragmentation of habitats due to construction and maintenance of the pipeline right-of-way; and temporary disruption of movement patterns of animals across the right-of-way. The most substantial wildlife impacts associated with the project will be the conversion of habitat in the permanent maintenance corridor.

**Species of Special Concern.** Impacts to terrestrial and wetland/aquatic plant and animal species identified as species of special concern are expected to be minimal and temporary. Temporary displacement of some species from the construction area will occur and for some species movement across the right-of-way will be hampered during construction activities. After completion of construction, however, the right of way will be allowed to naturally revegetate. Affected species of special concern are expected to return to the right-of-way. Impacts to the population of protected floral species are expected to be insignificant.

**Protected Areas.** Project activities will be conducted within two protected areas: the Gran Chaco National Park and the Historical National Park Santa Cruz La Vieja. Direct impacts to areas within the Gran Chaco National Park will be limited to clearing of the right-of-way. Indirectly, the possibility of increased hunting pressure within the park boundaries exists, and specific measures will be implemented to prevent it. The access road from San José de Chiquitos traverses the Santa Cruz La Vieja park. The park will be affected by road improvement work, but it may also be favored by the improved access which may promote tourism into the park.

## **6.4 IMPACTS ON THE SOCIOECONOMIC ENVIRONMENT**

### **6.4.1 Land Use**

Changes in land use are expected to occur as a result of the project implementation. However, the Project Sponsors plan to reinstate as much land as possible throughout project development, construction and operations. Four levels of land use impacts will potentially occur. In order of increasing severity they are:

**Temporary Land Use Change.** The temporary conversion of land to support pipeline and facility construction resulting in the loss of one to two years' plantings, but no displacement of households.

**Permanent Land Use Change without Resettlements.** It is the permanent loss of a portion of land holdings at facility sites impairing, but not eliminating, the economic viability of a household.

**Permanent Land Use Change with Resettlements.** It is the permanent loss of land that results in household resettlement. No displacement of households is anticipated in the project.

**Indirect Land Use Impacts.** A potentially significant impact is the increase in value of land near project facilities as a result of factors such as, improved access to that land, proximity to the new market for goods and services represented by manned project facilities.

#### **6.4.2 Social Impacts**

**Population.** The study area will experience a significant but temporary increase in population during the construction phase due to the influx of approximately 1,600 workers. While workers will be housed in camps along the right-of-way, it is expected that they will visit the main population centers, such as San José de Chiquitos, Roboré, and Puerto Suárez, in search of relaxation and entertainment during work breaks. One of the two 800-person camps will be located in El Carmen and the presence of the working crew will be continuous, adding to the demand for services in this town.

**Public Health and Safety.** With the temporary influx of population during construction, there may be a slight increase in contagious diseases (such as sexually transmitted diseases). Other health problems can be caused by parasitic diseases such as malaria.

Heavy equipment traveling along dirt roads would create noise and air pollution, affecting surrounding communities. Health related services, which are deficient in the study area, may face an increased demand, which could become critical in the event of an outbreak of contagious diseases.

**Education and Training.** Bolivian and expatriate project personnel will receive education and training in safety and health measures, environmental protection, and basic work practices. This education and training would be considered a beneficial impact of the project on the Bolivian national work force.

**Indigenous Peoples.** The three groups of indigenous people that are known to reside within or close to the study area and are likely to be impacted by the project are the Ayoreos, Chiquitanos, and Izozeños. The project would potentially impact the indigenous peoples at three levels: 1) The forest resources would be reduced as a result of clearing associated with the construction of the pipeline, which may also facilitate further forest exploitation for hunting and logging, 2) Opening up previously inaccessible areas of new forest could have the further impact of more forest clearing for agricultural purposes, thus reducing forest areas available for indigenous use, and 3) Some Indian villages might have been overlooked because of their small size.

**Cultural and Archeological Resources.** No significant impacts to cultural, archaeological, and historical resources have been identified. No archaeological resources have been identified along the pipeline alignment or along access road corridors based on literature research.

#### **6.4.3 Economic Impacts**

**Project Revenues.** The project would provide substantial direct financial revenues to the Republic of Bolivia through the sales of 8 MM CMD of natural gas in the first year up to 16 MM CMD in year eight. These sales will generate revenues for the central government (through corporate taxes), the regional governments of gas-producing areas (through local taxes locally known as regalías), the municipalities (through the new Law of Public Participation), and the retirement funds (through the capitalization shares). The central government will generate additional indirect revenues from employee income taxes resulting from project-related employment and aggregate value taxes (IVA in Spanish) on business transactions completed as a result of the construction and operation of the project. This increase in governmental revenues associated with the project would be considered a beneficial impact that would extend over the life of the project.



**Hiring and Wages.** Preliminary estimates of total personnel requirements indicate that approximately 1,000 jobs would be held by Bolivian nationals during peak construction of the pipeline. Wages for these workers over the one year construction period are projected at approximately U.S. \$4.8 million. The provision of wages and other benefits to Bolivian nationals would be considered a beneficial impact of the project. While positive, this effect will be temporary and will cease after construction is completed. The Project Sponsors will implement an aggressive nationalization plan to maximize the speedy replacement of expatriates with nationals.

**Labor Recruitment.** The availability of employment during the construction and operations phases of the project is a major expectation of the local population. The equitable distribution of jobs among people in the study area is a real concern of the local labor force. Labor recruitment and the potential for inequitable distribution of jobs would be considered a significant but mitigable impact.

**Workers Accommodations.** Housing would be required for both the construction and operations phases of the project. However, given the bussing and accommodation provisions of the project and the relatively low number of operations personnel and the ability of local towns to accommodate them, the need for housing during construction and operations would be considered a less-than-significant impact. During abandonment, the reduction in labor force may result in a minor surplus of housing in local villages and towns which is considered a less-than-significant impact.

**Infrastructure.** Road upgrades associated with the project would ease transportation problems for local residents and help reduce transportation costs associated with imports and exports. However, increased traffic flow associated with infrastructure upgrades may result in an increased accident risk to people and animals.

**Local Business Opportunities.** To spread the project's economic effects to local communities, the Project Sponsors are developing plans to encourage local business development so that goods and services can be purchased locally and infrastructure made available. This purchase of local

goods and services would also create indirect market development for foodstuffs, construction materials, and transportation.

After abandonment, the project demand for provisions and procurement would disappear. However, it is expected that the regional economy would have developed sufficiently to accommodate the change. As a result, abandonment would have a less-than-significant impact on the local and regional economy.

## **7.0 ENVIRONMENTAL MANAGEMENT PLAN**

The Environmental Management Plan (EMP) for the project is a master planning and management tool. It will establish guidelines and standards for measurement and plans that address all the environmental aspects of the project, including impact mitigation measures, environmental construction procedures, health and safety, community relations, impact compensation, environmental monitoring, and environmental maintenance.

The main objectives of the EMP are: 1) to avoid, minimize, control, or mitigate potential impacts from the project construction and operation on the physical, biological, and socioeconomic environment, and 2) to ensure continued project compliance with applicable environmental regulations.

The environmental management measures presented in Chapter 7.0 are a precursor to the final EMP, which will be prepared as part of the final design of the project. They provide a conceptual approach and an outline of the EMP and serve to establish the environmental standards to be followed in the execution of the project.

## **8.0 PUBLIC CONSULTATION PROGRAM**

A Public Consultation Program (PCP) was conducted during the preparation of the EIS for the Bolivia-Brazil Gas Pipeline project. The approach followed for the PCP consisted of a series of visits and public meetings with government ministries, local Non-Governmental Organizations (NGOs) based in the cities of La Paz and Santa Cruz, local communities settled in the general

vicinity of the proposed Bolivia-Brazil Gas Pipeline Project and organizations of indigenous peoples. The PCP Team consisted of sponsor representatives from YPF, Enron, and the BTB Group, and specialists from Dames & Moore.

This consultation assisted with identification of possible project impacts, reconciliation of opposing views about the project, discussion of licensing requirements, promotion of understanding of the nature and extent of any social or environmental impacts, and fulfillment of the requirements of the Bolivian's new Environmental Law.

The scope of work of the Public Consultation Program included the following tasks:

- Development of a project brochure that summarizes the technical components of the project along with the main environmental and socioeconomic issues. A total of 900 brochures were distributed in the public meetings.
- Preparation of two socioeconomic questionnaires designed to gather supplemental information for the socioeconomic conditions chapter of the EIS. Six copies of a long version questionnaire were distributed to the local authorities of each town. A total of 301 copies of a short version questionnaire were collected during the public meetings. Copies of the project questionnaires are included in the Appendix.
- Four consultation meetings with government officials to discuss the project related environmental and socioeconomic matters and identify the range of environmental and socioeconomic issues to be included in the EIS.
- Five meetings with local NGO's to identify and develop an understanding of key issues that should be addressed in the EIS and communicate an understanding of the project goals and objectives.
- Six public meetings attended by approximately 800 to 900 people to gain a broad understanding of the environmental and socioeconomic setting of the pipeline corridor, local communities, and surrounding area.

The input derived from the PCP has been incorporated into the socio-economic impact assessment discussed above in Section 6.4.

## 9.0 CONCLUSIONS AND RECOMMENDATIONS

The following conclusions have been derived from the development of the EIS:

- The area of influence of the project, defined here as the study area, includes three main ecological units: the mostly-flat alluvial plains of the Llanura Chaqueña, the marshes of the Bañados de Izozog and Otuquis, and the hills and foothills of the Serranías Chiquitanas.
- Through much of the study area, land use is sparse, partly due to limited land use capability associated with poor soils, low precipitation, and a lack of readily available surface and groundwater. Native, undisturbed vegetation is prevalent throughout the study area.
- The population in the study area is small, and largely concentrated in five population centers located along the railroad: Pailón, San José de Chiquitos, Roboré, El Carmen, and Puerto Suárez/Puerto Quijarro. Additionally, in the vicinity of the study area the Capitanía del Alto y Bajo Izozog (CABI) is the umbrella organization for 22 Izozeño Indigenous groups settled along the Parapetí River.
- The Gran Chaco National Park is considered the most environmentally sensitive area within the study area, due to its protected status, large biological resources, indigenous populations, and biogeographic status. The pipeline right-of-way will traverse the Integrated Management Area of the park, which will not represent a conflict with allowable land uses within this area.
- Throughout most of the study area, the physical and biological environment seems to be resilient to the type and magnitude of impacts anticipated to occur because of the project: the primary direct impact is the widening of an already cleared swath 5-10 wide. The western part of the study area is criss-crossed with 3 to 30 year old cut lines from seismic surveys with no negative secondary effects observed during this study.

- The proposed pipeline alignment was selected because it traverses relatively homogeneous terrain and avoids areas of slope instability and populated areas. This route was determined to balance best the overall impacts to the human, biological, and physical environment while achieving its overall purpose, which is to transport natural gas from production fields in Bolivia to the markets in southern Brazil through an environmentally acceptable and economically viable transportation project.
- The logistics assessment had identified the locality of Naranjos as a storage area with an access road connection to the pipeline right-of-way. The area reconnaissance revealed the existence of a nearly pristine mesic forest between Naranjos and the right-of-way. Evidence of incipient human encroachment into this area was observed along a narrow access road built three years ago. It was decided that this location and access road would not be used to prevent additional direct impacts to the forest and to discourage further encroachment along the access road.
- As originally proposed, the route was designed to traverse the Cañón de la Victoria across its narrowest point, thus minimizing the length of the direct impact to the wetland. The Cañón de la Victoria is a hydrologic and biological connection between the wetland systems of the Bañados de Otuquis, in Bolivia, and the Pantanal, in Brazil. The review of the area suggested that the pipeline crossing at the narrowest point would affect a nearly pristine marsh and may affect the hydrologic connection between the systems. A route modification was proposed to make the route parallel to the existing road/railroad corridor, where the pipeline would traverse a longer section of the floodplain, but along an already disturbed corridor. Thus, the new route will result in minimal additional impacts to this regional wetland system.
- The main anticipated negative impacts of the project in its area of influence will be: a) the removal of vegetation and wildlife habitat along the right-of-way, b) the increase in the potential for erosion, sedimentation, and hydrology disruption due to project construction activities, c) the potential for increased hunting pressure on species of special concern, d) the potential for promoting colonization of undisturbed areas, and e) the potential disruption of the hydrologic patterns in the rivers and Bañados.

- The primary anticipated positive impacts of the project will be: a) an increase in revenues for Bolivia from the sale of gas to Brazil, b) a redistribution of those revenues back into the area of influence of the project, c) a temporary increase in employment within the study area, d) an improvement in the road infrastructure, which is needed to execute the project, e) an increase in the demand for goods and services in the study area, which may promote wholesale and retail commerce in the area, and f) a contribution to an Endowment Fund to supplement existing funds allocated for the management of the Gran Chaco National Park and the protected park areas in the Department of Santa Cruz.

To ensure that the project is executed within the environmental and socioeconomic limits established by the regulatory framework and outlined in the Environmental Management Plan, the following recommendations are offered:

- Final design of the project should refine procedures, and design parameters to fully respond to the environmental concerns identified in this Environmental Impact Study.
- Implementation of the Environmental Management Plan presented in the EIS is required to provide appropriate mitigation of unavoidable impacts and lower the significance of negative impacts to acceptable levels under the current Bolivian regulatory framework and international standards.
- The project sponsors should continue to track the public's perception regarding the project in order to evaluate new or changed concerns as they relate to the final design and execution of the project.

**TABLE ES-1  
SUMMARY OF IMPACTS AND MITIGATION MEASURES FOR THE BOLIVIA-BRAZIL GAS PIPELINE PROJECT (BOLIVIAN PORTION)**

<b>ENVIRONMENTAL PARAMETER</b>	<b>IMPACT AND CAUSAL ACTIVITY</b>	<b>CLASSIFICATION</b>	<b>COMMENTS</b>	<b>KEY MITIGATION MEASURES</b>
Climate	No impacts on climate parameters are expected	N/A	N/A	N/A
Air Quality	Release of dust and particulate due to construction activities and traffic	Adverse, Direct, Temporary, Localized, Proximal, Reversible, Mitigable, Less than Significant.	Effects are expected to be largely avoidable. Actual emissions will likely be minimal and localized.	If available, water should be used to wet construction areas (Section 7.5.5).
	Emission of contaminants from engines and other equipment operation	Adverse, Direct, Temporary, Localized, Proximal, Reversible, Mitigable, Less than Significant.	Effects are expected to be largely avoidable. Actual emissions will likely be minimal and localized.	Proper engine and equipment maintenance and minimization of operation times (Section 7.5.5).
	Emissions associated with turbines at compressor stations	Adverse, Direct, Permanent, Localized, Proximal, Reversible, Mitigable, Significant	Screen-modeling suggests that some Bolivian standards could be exceeded.	Final design will incorporate measures to ensure compliance with applicable regulations (Section 7.5.5).
Geology	Need for blasting due to rock outcroppings	Adverse, Direct, Permanent, Localized, Proximal, Irreversible, Mitigable, Less than Significant.	Outcrops are unlikely throughout the route. Higher probability of occurrence in the Puerto Suárez area.	If blasting is necessary, best management techniques for blasting will be employed (Appendix B).
	Likelihood of earthquakes affecting the pipeline	(earthquakes would affect pipeline safety and operation)	Earthquake records suggest that earthquakes are unlikely.	Design considerations will provide for standard pipeline protection (Appendix B).

**TABLE ES-1**  
**SUMMARY OF IMPACTS AND MITIGATION MEASURES FOR THE BOLIVIA-BRAZIL GAS PIPELINE PROJECT (BOLIVIAN PORTION)**

<b>ENVIRONMENTAL PARAMETER</b>	<b>IMPACT AND CAUSAL ACTIVITY</b>	<b>CLASSIFICATION</b>	<b>COMMENTS</b>	<b>KEY MITIGATION MEASURES</b>
Geomorphology (land forms)	Changes in local topography due to cut and fill, grading, and road improvement activities.	Neutral, Direct, Temporary, Localized, Proximal, Reversible, Mitigable, Less than Significant	Changes on the land forms will be negligible.	Restore original grade (Section 7.5.1).
Soils	Increased erosion potential due to vegetation clearing, trenching, spoil piling, road improvements, and other construction activities.	Adverse, Indirect, Temporary, Localized, Proximal, Reversible, Mitigable, Less than Significant	Much of the area of influence is rather flat, with low precipitation, and natural vegetation cover, which reduce the potential for erosion. Observations on the 3-yr old cut line suggests low erosion potential.	Application of erosion prevention and control techniques (Section 7.5.1).
	Soils compaction due to heavy traffic on the ROW.	Adverse, Direct, Temporary, Localized, Proximal, Reversible, Mitigable, Significant.	Much of the ROW traverses areas of Quaternary deposits, likely prone to compaction.	Soils restoration techniques during final grade (Section 7.5.1).
	Potential scouring and bank erosion due to stream crossing activities.	Adverse, Indirect, Temporary, Localized, Proximal, Reversible, Mitigable, Less than Significant.	Water courses along the route tend to have shallow cross-section, with gently sloping banks and low scouring.	Application of wetland and stream crossing techniques (Section 7.5.2).
	Other potential effects: Soil layers mixing, nutrient leaching, loss of organic layer.	Adverse, Direct, Temporary, Localized, Proximal, Reversible, Mitigable, Less than Significant	Immediate effects are more likely to be significant in wetland areas where an organic layer exists. In most of the route, soils are sandy, with poor horizon development and little or no organic layer.	Application of appropriate construction final grading techniques (Sections 7.5.1, 7.5.2).



**TABLE ES-1  
SUMMARY OF IMPACTS AND MITIGATION MEASURES FOR THE BOLIVIA-BRAZIL GAS PIPELINE PROJECT (BOLIVIAN PORTION)**

ENVIRONMENTAL PARAMETER	IMPACT AND CAUSAL ACTIVITY	CLASSIFICATION	COMMENTS	KEY MITIGATION MEASURES
Soils (cont...)	Potential sudden erosion due to discharge of hydrotest water.	Adverse, Direct, Temporary, Localized, Proximal, Reversible, Mitigable, Less than Significant.	Hydrotest water will be discharged in upland areas.	Application of measures to minimized the potential for erosion, such as energy dissipation devices (Section 7.5.3).
Groundwater	Potential mixing of aquifers.	Adverse, Indirect, Permanent, Localized, Remote, Reversible, Not Mitigable, Less than Significant	Groundwater resources seem to be adequate for the project with relatively high annual recharge. Effects are likely to be less than significant with the application of appropriate management techniques.	Groundwater resources will be evaluated before well establishment to determine if they meet project needs. Wells will be cased to avoid aquifer interaction (Section 7.5.4).
	Potential groundwater contamination in the case of accidental spills.	Adverse, Direct, Temporary, Localized, Remote, Reversible, Not Mitigable, Less than Significant		
	Potential lowering of the water table due to withdrawal of water for camps.	Adverse, Direct, Temporary, Localized, Remote, Reversible, Not Mitigable, Less than Significant		
Surface Water	Potential increase in sediment loads due to construction activities.	Adverse, Direct, Temporary, Localized, Proximal, Reversible, Mitigable, Less than Significant.	The main rivers to be crossed are shallow and carry important sediment loads. The additional load is likely to be insignificant.	Application of erosion and sedimentation control measures (Section 7.5.1).

**TABLE ES-1**  
**SUMMARY OF IMPACTS AND MITIGATION MEASURES FOR THE BOLIVIA-BRAZIL GAS PIPELINE PROJECT (BOLIVIAN PORTION)**

ENVIRONMENTAL PARAMETER	IMPACT AND CAUSAL ACTIVITY	CLASSIFICATION	COMMENTS	KEY MITIGATION MEASURES
Surface Water (cont.)	Temporary disruption to local hydrology (drainage patterns) due to wetland and water body crossing activities.	Adverse, Direct, Temporary, Localized, Proximal, Reversible, Mitigable, Less than Significant.	Most water crossings will be on shallow, slow flowing waters, thus reducing the magnitude of potential effects on local drainage patterns. Similarly, low rainfall reduces the risk of drainage problems.	Application of special wetland and water body construction techniques (Section 7.5.2).
	Permanent modification of local drainage patterns due to placement of fill and impervious surface for project facilities (e.g., compressor stations).	Adverse, Direct, Permanent, Localized, Proximal, Reversible, Mitigable, Less than Significant.	This potential impact is considered less than significant because of low rainfall, generally flat terrain, and limited placement of fill and impervious surfaces.	Proper design of stormwater management systems and cross drains where necessary (Appendix B).
	Potential reduction in surface water availability at the source due to withdrawal for hydrostatic testing.	Adverse, Direct, Permanent, Localized, Proximal, Reversible, Mitigable, Less than Significant.	The main sources of hydrotest water will be the Río Grande, Río San Miguel and Río Otuquis. Withdrawal will be limited to protect aquatic life, and preserve water volumes for other uses downstream.	This impact can be avoided with proper calculation of surface flow and withdrawal rate and volume (Section 7.5.3).
	Potential contamination of surface waters due to accidental spills.	Adverse, Direct, Temporary, Localized, Proximal, Reversible, Mitigable, Less than Significant.	Project activities will require the utilization of hazardous materials such as gasoline, oil, and paints, but in small quantities and in localized areas.	This impact can be largely avoided by applying proper techniques to manage and dispose hazardous materials (Section 7.5.6).

**TABLE ES-1  
SUMMARY OF IMPACTS AND MITIGATION MEASURES FOR THE BOLIVIA-BRAZIL GAS PIPELINE PROJECT (BOLIVIAN PORTION)**

ENVIRONMENTAL PARAMETER	IMPACT AND CAUSAL ACTIVITY	CLASSIFICATION	COMMENTS	KEY MITIGATION MEASURES
Surface Water (cont...)	Potential contamination of surface waters due to untreated discharges of domestic wastewater.	Adverse, Direct, Temporary, Localized, Proximal, Reversible, Mitigable, Less than Significant.	Domestic wastewater will be generated mainly at the workers camps.	Proper treatment and discharge of domestic wastewater (Section 7.5.6).
	Potential contamination of surface water (and groundwater) due to improper solid wastes disposal.	Adverse, Direct, Temporary, Localized, Proximal, Reversible, Mitigable, Less than Significant.	Solid and domestic wastes will be produced in all construction and camp areas.	Waste management must include minimization, separation, recycling, and proper disposal procedures (Section 7.5.6).
Vegetation	Removal of vegetation biomass due to clearing activities.	Adverse, Direct, Temporary, Localized, Proximal, Reversible, Mitigable, Significant.	A 5-m cut line along the majority of the route was established in 1993. The project will result in additional impacts on this existing disturbance.	This impact is unavoidable. Localized revegetation and compensation will be provided (Sections 7.5.1 and 7.6.1).
	Removal of individuals of species of special concern.	Adverse, Direct, Temporary, Localized, Proximal, Mitigable, Less than Significant.	In the Dry Chaco area, a number of endemic species as well as species used for different purposes will be affected.	This impact is unavoidable but it will be minimized by containing the clearing within the right of way (Section 7.6.1).
	Loss of tall forest canopy in the Bañados de Izozog (Río Parapetí) and low forest canopy in the Dry Chaco.	Adverse, Direct, Permanent, Localized, Proximal, Mitigable, Less than Significant.	In the Bañados, the presence of vines may result in falling trees dragging adjacent trees located outside the ROW. This is not the case in the vine-free uplands.	This impact is unavoidable but it will be minimized by containing the clearing within the right of way (Section 7.6.1).

**TABLE ES-1  
SUMMARY OF IMPACTS AND MITIGATION MEASURES FOR THE BOLIVIA-BRAZIL GAS PIPELINE PROJECT (BOLIVIAN PORTION)**

<b>ENVIRONMENTAL PARAMETER</b>	<b>IMPACT AND CAUSAL ACTIVITY</b>	<b>CLASSIFICATION</b>	<b>COMMENTS</b>	<b>KEY MITIGATION MEASURES</b>
Fauna	Direct incidental loss of individuals (including species of special concern) due to construction activities.	Adverse, Direct, Temporary, Localized, Proximal, Mitigable, Less than Significant.	Slow moving and/or small terrestrial animals, such as tortoises, are most likely to be affected. Snakes are likely to be particularly affected given human aversion toward them.	This impact can be minimized by applying common sense and training the work force about protecting the natural resources (Sections 7.6.1 and 7.8.1).
	Increase in the hunting pressure on large mammals and reptiles (including species of special concern)	Adverse, Direct, Temporary, Localized, Proximal, Mitigable, Significant.	Perhaps the most important potential impact due to the remoteness of the area, the abundance of wildlife, and the special concern status of many species.	Strict measures will be applied to avoid undue impacts on wildlife (Sections 7.6.1 and 7.7.1).
	Potential entrapment of fish at intake for hydrotest water.	Adverse, Direct, Temporary, Localized, Proximal, Mitigable, Less than Significant.	This impact is largely avoidable.	Provisions will be made to prevent fish and other animals from entering the intake (Section 7.5.3).
	Permanent loss of habitat along the cleared ROW.	Adverse, Direct, Permanent, Localized, Proximal, Mitigable, Less than Significant.	This will affect mostly insects and other small animals. Most animal will move away from the ROW. At the regional level, the loss of habitat is negligible.	This impact is unavoidable but it will be minimized by containing the clearing within the right of way (Section 7.7.1).
	Habitat fragmentation due to the establishment of the ROW.	Adverse, Direct, Permanent, Localized, Proximal, Mitigable, Less than Significant.	A cut line has already been established throughout the majority of the route. The additional impact is considered negligible.	This impact is unavoidable but it will be minimized by containing the clearing within the right of way (Section 7.7.1).

**TABLE ES-1  
SUMMARY OF IMPACTS AND MITIGATION MEASURES FOR THE BOLIVIA-BRAZIL GAS PIPELINE PROJECT (BOLIVIAN PORTION)**

<b>ENVIRONMENTAL PARAMETER</b>	<b>IMPACT AND CAUSAL ACTIVITY</b>	<b>CLASSIFICATION</b>	<b>COMMENTS</b>	<b>KEY MITIGATION MEASURES</b>
Species of Special Concern	Direct loss through incidental mortality, increased hunting, or secondary habitat effects.	Adverse, Direct, Temporary, Localized, Proximal, Mitigable, Less than Significant.	Species of special concern are rather abundant in the project area.	This impact is unavoidable but it will be minimized by containing the clearing within the right of way and strictly enforcing species protection measures (Sections 7.6.1 and 7.7.1).
Protected Areas	Encroachment into the Gran Chaco National Park and the Historic National Park Santa Cruz la Vieja.	Adverse, Direct, Permanent, Localized, Proximal, Mitigable, Less than Significant.	The project does not represent conflict with approved land uses in the parks.	This impact is unavoidable, but it will be minimized and compensated (Sections 7.7.1 and 7.8.4).
Population	Slight and temporary increase in the population of the study area due to the influx of 1000-1500 workers.	Beneficial, Direct, Temporary, Extended, Proximal, Significant	It is unlikely that pipeline workers will settle permanently in the study area.	Measures will be taken to accommodate the incoming workers (Section 7.7.2).
	Potential for cultural and social tension due to the interaction between residents and incoming workers.	Adverse, Direct, Temporary, Localized, Proximal, Mitigable, Less than Significant.	Cultural and social differences may arise.	Measures will be applied to promote positive interactions and a productive cultural exchange between residents and incoming workers (Section 7.7.2).

**TABLE ES-1  
SUMMARY OF IMPACTS AND MITIGATION MEASURES FOR THE BOLIVIA-BRAZIL GAS PIPELINE PROJECT (BOLIVIAN PORTION)**

<b>ENVIRONMENTAL PARAMETER</b>	<b>IMPACT AND CAUSAL ACTIVITY</b>	<b>CLASSIFICATION</b>	<b>COMMENTS</b>	<b>KEY MITIGATION MEASURES</b>
Population (cont...)	Potential for a slight increase in the incidence of contagious diseases, including sexually transmitted diseases due to the interaction between residents and incoming workers.	Adverse, Direct, Temporary, Localized, Proximal, Mitigable, Less than Significant.	Camp workers will visit nearby communities occasional in search of relaxation and entertainment.	Measures will be applied to promote hygiene and safe practices (Section 7.7.4).
Economy	Potential for a temporary increase in the demand for services and goods to accommodate the influx of workers into the study area.	Beneficial, Direct, Temporary, Extended, Proximal, Significant	Camp worker are expected to spend a portion of their pay locally.	None necessary.
	Temporary employment of 500-1000 unspecialized local labor for construction-related work.	Beneficial, Direct, Temporary, Extended, Proximal, Significant.	There are significant opportunities for local recruitment for the pipeline labor force.	Fair hiring and remuneration practices will be applied.
	Potential increase in transportation-dependent activities due to improvements on the road system.	Beneficial, Direct, Permanent, Temporary, Extended, Proximal, Significant.	There are significant opportunities for tourism promotion.	None necessary. Local areas with tourism potential (e.g., hot springs at the Río Aguas Calientes headwaters) will be protected during project construction.
Land Use	Potential for changes in land use patterns.	Neutral, Direct, Permanent, Localized, Less than Significant.	The pipeline project does not represent conflicts with existing or planned land uses.	This impact is considered negligible.

**TABLE ES-1**  
**SUMMARY OF IMPACTS AND MITIGATION MEASURES FOR THE BOLIVIA-BRAZIL GAS PIPELINE PROJECT (BOLIVIAN PORTION)**

ENVIRONMENTAL PARAMETER	IMPACT AND CAUSAL ACTIVITY	CLASSIFICATION	COMMENTS	KEY MITIGATION MEASURES
Indigenous Populations	Encroachment into the historical range of Ayoreode and Izoceños groups.	Neutral, Direct, Permanent, Localized, Less than Significant.	Their territory has been afforded protection through the establishment of the Gran Chaco National Park.	Compensatory measures will be applied to assist in the consolidation of the management plan for the park (Section 7.8.4).
Cultural, Archaeological, and Historical Resources	Potential disturbance to sites of special concern.	Adverse, Direct, Permanent, Localized, Proximal, Mitigable, Less than Significant.	No sites of special concern were identified along the pipeline alignment. Historical resources occur particularly in and around San José de Chiquitos.	A contingency plan will be applied for incidental finding of sites of special concern (Section 7.7.3).

TABLE ES-2					
SUMMARY OF ESTIMATED COSTS ASSOCIATED WITH THE IMPLEMENTATION OF THE ENVIRONMENTAL MANAGEMENT PROGRAM					
EMP COMPONENT (CHAPTER SECTION)	MEASURE	UNIT	UNIT COST	NUMBER OF UNITS	TOTAL COST
Erosion Control, Revegetation	Revegetation of aeolic plains at Río San Miguel	Plants	Install plants; one-year survival guarantee included	12 ha (120,000 m <sup>2</sup> )	<b>Total \$180,000</b>
Environmental Inspection	Inspection Plan	Environmental Manager <sup>(1)</sup>	\$13,000/mo.	1 Manager (15 mos)	\$195,000
		Chief Inspector <sup>(1)</sup>	\$9,000/mo.	2 Chief Inspectors (10 mos)	\$180,000
		Inspectors <sup>(1)</sup>	\$7,000/mo.	4 Inspectors (9 mos)	\$252,000
		Trucks	\$3,200/mo.	1 Truck (15 mos) 2 Trucks (10 mos) 4 Trucks (9 mos)	\$227,200
		Fuel & Maintenance	\$750/mo.	1 Truck (15 mos) 2 Trucks (10 mos) 4 Trucks (9 mos)	\$53,250
					<b>Total \$907,450</b>
Compensatory Mitigation	National Park Management	Rangers, facilities, operations, and maintenance	Annual interest contributed toward operational cost	Donation to National Endowment Fund, estimated at 10% yearly return to cover investment and operating expenses	<b>Total \$1,000,000</b>



TABLE ES-2 SUMMARY OF ESTIMATED COSTS ASSOCIATED WITH THE IMPLEMENTATION OF THE ENVIRONMENTAL MANAGEMENT PROGRAM						
EMP COMPONENT (CHAPTER SECTION)	MEASURE	UNIT	UNIT COST	NUMBER OF UNITS	TOTAL COST	
Protection of Wildlife and the Right-of-Way	Signage and Barricade Program	Signs & ROW	\$200/sign	560	\$112,000	
		Barriers & Gates	\$1,400/gate	82	\$115,000	
		<b>Total</b>				<b>\$227,000</b>
Community Relations	Water and Generator donation to the community	Well	\$80,000	4 - San José, Roboré, El Carmen, CABI	\$320,000	
		Pumps and Other	\$25,000	4	\$100,000	
		<b>Total</b>				<b>\$420,000</b>
		Generator (3)	\$76,000	1 - San José	\$76,000	
			\$93,000	2 - El Carmen	\$186,000	
<b>Total</b>				<b>\$262,000</b>		
	Building	\$30,000	1 - Pailón	<b>Total</b>	<b>\$30,000</b>	

TABLE ES-2					
SUMMARY OF ESTIMATED COSTS ASSOCIATED WITH THE IMPLEMENTATION OF THE ENVIRONMENTAL MANAGEMENT PROGRAM					
EMP COMPONENT (CHAPTER SECTION)	MEASURE	UNIT	UNIT COST	NUMBER OF UNITS	TOTAL COST
Community Relations	Public Education Program	Professionals	Public Education Manager at \$40/hr	520 hr	\$20,800
			Public Education Trainers at \$20/hr	Two for 520 hr each	\$20,800
		Materials	Miscellaneous supplies and brochure materials	Enough to cover 3,000 people (panphlets)	\$20,000
	<b>Total \$61,600</b>				
	Public Communications Program	Public Communications Officer	One at \$2000/mo	For 2 years	<b>Total \$48,000</b>
<b>Total Cost of Mitigation Measures:</b>					<b>\$3,136,050</b>

<sup>(1)</sup> Salary plus living expenses.

**CHAPTER 1.0  
INTRODUCTION**

**TABLE OF CONTENTS**

1.0	INTRODUCTION .....	1-1
1.1	BACKGROUND .....	1-1
1.1.1	General .....	1-1
1.1.2	Purpose of the Project .....	1-2
1.1.3	Project Overview .....	1-3
1.2	OBJECTIVES OF THE STUDY .....	1-4
1.3	METHODOLOGY .....	1-5
1.4	REPORT .....	1-10
1.5	PROFESSIONAL STAFF .....	1-11

## LIST OF FIGURES

<u>FIGURE</u>	<u>DESCRIPTION</u>
1.1	BOLIVIA TO BRAZIL PROPOSED PIPELINE ALIGNMENT

## 1.0 INTRODUCTION

### 1.1 BACKGROUND

#### 1.1.1 General

This document presents an updated Environmental Impact Study (EIS) completed by Dames & Moore for the Bolivian portion of the proposed Bolivia to Brazil natural gas transmission pipeline (Bolivia-Brazil Gas Pipeline Project). This study was conducted in accordance with the requirements established in the Professional Services Agreement No. PSA-02-95 signed between Enron Power Corporation (Enron) and Dames & Moore. The study was carried out from December 1995 to June 1996.

Prior to Dames & Moore's involvement in the project, a previous Environmental Impact Study (Original Assessment) was completed in 1990 by a Bolivian consultant, the "*Centro de Investigaciones y Estudio de la Capacidad de Uso Mayor de la Tierra*" (CUMAT)". The results of the previous study were presented in a report entitled "Evaluación de Impacto Ambiental para la Construcción del Gasoducto y la Planta Eléctrica a Vapor Puerto Suárez" (Environmental Impact Assessment for the Construction of the Gas Pipeline and Puerto Suárez Steam-Electric Power Plant) and dated September, 1990.

This EIS has been prepared to identify and address environmental issues related to project facilities to be located and operated in Bolivia. The study has been designed to support applications from the Project Sponsors to international financing institutions for project funding, and to comply with the requirements of the new Bolivian environmental law. Separate EIS documents are being prepared by another consultant to identify and address issues related to project facilities to be located and operated in Brazil.

In addition to meeting requirements of the World Bank and other potential funding organizations, the preparation and submission of this EIS document provides a vehicle for the presentation of the environmental aspects of the project. These aspects have been, and will continue to be fully

integrated into the planning, design, development, construction, operation, and eventual decommissioning of the project.

Expert and independent environmental advice has been an integral part of preliminary engineering for the project, particularly in the integration of environmental specialists in numerous field teams that have investigated, developed, and refined the route of the pipeline, and the location of facilities for the project. This reflects a key project development strategy to minimize environmental impacts of the project by the early recognition and, where possible, avoidance of sensitive areas and locations.

### **1.1.2 Purpose of the Project**

Bolivia is a gas producing country with a significant surplus of natural gas in relation to its internal consumption, while Brazil has a shortage of energy supply. These two countries have a signed contract for the purchase-sale of natural gas between YPFB and Petrobras, their national oil companies. The contract defines the amount of natural gas to be exported in a 20-yr period and specifies that the natural gas volumes to be transported will start at 8.0 MM CMD in the first year, growing in seven years to 16.0 MM CMD, and staying at that quantity for the remaining thirteen years of the contract. Depending on market demands, the gas volume to be transported may increase; the maximum transport capacity is 20 MMCMD.

The purpose of the proposed pipeline project addressed in this study is to transport and sell the natural gas exploited in central Bolivia to the major industrial centers of southern Brazil in response to their growing demand for energy. The project is being developed by YPFB and Petrobras, together with participating partners Enron Corporation in the Bolivian sector and the BTB Group in the Brazilian sector. The BTB Group represents a consortium comprised of Broken Hill Proprietary Company Limited (BHP), Tenneco Gas, and British Gas. The majority equity interest in the project is held by YPFB and Petrobras.

The project is proposed to provide Bolivia with a necessary new source of revenues and to help satisfy Brazil's growing energy needs. The project has been designed to avoid or reduce to

acceptable levels potentially significant adverse impacts to the human, biological, and physical environments.

### 1.1.3 Project Overview

The Republic of Bolivia is located in the central region of South America and has common borders with five countries: to the north and east with Brazil, to the southeast with Paraguay, to the south with Argentina, to the southwest with Chile, and to the northwest with Perú. The Bolivian portion of the pipeline route is located in southeast Bolivia and crosses the Departamento of Santa Cruz in an east to southeast direction.

The proposed pipeline will originate at the YPFB Río Grande Natural Gas Processing Plant located approximately 40 km southeast of the city of Santa Cruz de la Sierra, Bolivia. The pipeline route proceeds in a southeastern direction for approximately 3,100 km to Porto Alegre in southern Brazil. The Bolivian portion of the route (Figure 1.1) is located south of the rail system between Santa Cruz (Bolivia), and the Puerto Suárez/Corumbá, (Brazil) area and will be approximately 557 km long. The Bolivian portion of the project, considered in this EIS, is comprised of the following major components:

- **Gas Pipeline.** A 32" diameter, approximately 557 km long pipeline which would extend from the Río Grande plant to the Bolivia-Brazil border at a point located approximately 15 km southeast of Puerto Suárez. Pipeline installation will include anticorrosive external coating, as well as the application of a cathodic protection system for all underground sections. The right-of-way in Brazil will be 20-meters wide; however, due to the lack of infrastructure on the Bolivian side, the right-of-way will be 30-meters wide during construction. This width will provide sufficient space to accommodate two-way construction traffic and pipeline installation activities. During operation, a 17-meters permanent right-of-way will be maintained.
- **Compressor Stations.** Four compressor stations will be located along the pipeline to boost pressure in the pipeline and maintain adequate flow rates of the natural gas. The compressor stations will be built as needed as export volumes increase with time. The

compressor stations will be automated and have minimal staff. In addition to the compressor stations, the pipeline will include pig launchers/receivers and metering stations.

- **Related Infrastructure.** Five pipe storage yards will be located along the Puerto Suárez-Santa Cruz railroad system. Rail siding infrastructure will be constructed inside one of the existing port facilities in Puerto Quijarro to receive and distribute project cargo. The storage yards will be at Santa Cruz, Pailón, San José de Chiquitos, Roboré, El Carmen, and Puerto Quijarro. Infrastructure upgrades also would include the repair/upgrade of existing roads and bridges.
- **Fiber Optic Cable.** The installation of a fiber optic cable will be included within the scope of the project. The cable may either be placed in the same trench as the pipeline or in a separate trench within the pipeline right-of-way.

A detailed description of the project is presented in Section 3.0 of this document.

## 1.2 OBJECTIVES OF THE STUDY

The purpose of this EIS was to update the Original Assessment and to reflect changes in the scope of the project. In addition, the EIS was expanded to respond to the current requirements of the Bolivian environmental regulations and the environmental performance guidelines of international financial institutions. The objectives of the EIS were to ensure that: 1) the project is constructed and operated in an environmentally sound manner, and 2) that issues of concern relating to the human, biological, and physical environments (including applicable Republic of Bolivia regulations and World Bank environmental and health and safety guidelines) are recognized early and considered in the project design and execution.

The EIS provides a detailed project description and addresses a variety of topics, including a discussion of route alternatives; legislative, regulatory and policy considerations; existing environmental and socioeconomic (baseline) conditions; impacts identified as a result of project implementation; and mitigation measures that would be implemented to reduce significant adverse



project impacts to less-than-significant levels. In addition, the EIS presents a discussion of the public consultation program that has taken place to date with relevant government agencies, Non-Governmental Organizations, and affected communities.

Coordination and consultation with affected agencies, NGOs, communities, and individuals throughout the EIS planning and development phase of the project has helped to identify potential impacts. As a result, a number of measures to avoid, reduce, or compensate for such impacts have been incorporated into the project scope.

The project is classified as a Category A project under the World Bank environmental review procedures. This classification means that it potentially could have significant adverse impacts on the natural environment or the social circumstances of the project area. For such projects, a full environmental assessment following appropriate World Bank guidelines is required.

The following World Bank guidelines provided support for preparing this EIS:

- Environmental Assessment Sourcebook (1991a; updated 1993)
- Operational Directive 4.01 (Environmental Assessment) (1991b)
- Operational Directive 4.20 (Indigenous Peoples) (1991c)
- Operational Directive 4.30 (Involuntary Resettlement) (1990a)
- Operational Policy Note 11.02 (Wildlands) (1986)
- Technical Paper No. 55 (Techniques for Assessing Industrial Hazards: A Manual) (1988a)
- Technical Paper No. 80 (Involuntary Resettlement in Development Projects) (1988b)
- The Forest Sector: A World Bank Policy Paper (1991d)
- Environmental Health and Safety Guidelines (as updated, 1994a)
- IFC Environmental Analysis and Review of Projects (IFC, 1993).

### 1.3 METHODOLOGY

The EIS was based on a comprehensive review of existing information, field work, and community workshops which were completed to evaluate the biophysical and socioeconomic environments in the area of influence of the project. Technical and environmental concepts were integrated in the analysis to ensure that the pipeline is constructed, operated, and managed in accordance with the conditions presented by the project's natural and social surroundings. Efforts were directed at maximizing the project's benefits in the area of influence, while preventing and mitigating its potential negative effects.

The methodology utilized to conduct this study included the following activities:

- Research, review, and evaluation of existing information and data on the region's physical, biological, meteorological, sociological, economic, and demographic characteristics. This activity included a review of the EIS prepared by CUMAT in 1990.
- Review of current Bolivian laws, regulations, decrees, and guidelines applicable to the project, as well as a review of the current institutional organization and the jurisdictional boundaries of each governing body. This task also included a review of the World Bank's environmental guidelines applicable to onshore oil and gas projects.
- Meeting with Bolivian Government authorities to identify and discuss the main issues related to the licensing process associated with the new Bolivian Law of Environment and its implementation.
- Meeting with active NGOs in Bolivia and potentially affected communities to present the project, and consult issues of concern related to the construction and implementation of the project.
- Preparation of a project description including the proposed infrastructure and the activities necessary to build and operate the project.

- Field reconnaissance activities to confirm, update, and supplement the available information, and to characterize the study area from an environmental and socioeconomic perspective. This field work was completed in three phases:

**Initial Reconnaissance:** The project team performed a preliminary reconnaissance of the study area on February 28-30, 1996. A general perception of the study area was gathered through a site overflight along the pipeline corridor between the cities of Santa Cruz and Puerto Suárez, and a ground tour of the Puerto Suárez-Yacuces segment. The objectives of the initial reconnaissance were: 1) to identify environmentally sensitive areas and areas that required special analysis, 2) to verify features of the local geology and vegetation types, and 3) to confirm available cartographic information.

**Groundtruthing:** On April 10-19, the project team conducted a second field trip, consisting of a ground assessment of preselected areas located along the proposed pipeline right-of-way. The objectives of the ground assessment were: 1) to verify the current land use and vegetative cover, 2) to describe the types of vegetation, 3) to assess wildlife occurrence and habitat use, 4) to prepare lists of the dominant species in each major vegetation type, and 5) to verify the relationship between vegetation types, hydric regimes, and land use.

**Public Consultation Program:** From May 17 to May 25, 1996, the project team along with project sponsor representatives conducted a third field trip, consisting of a series of visits to the main settlements located along the Santa Cruz-Puerto Suárez railroad. The objectives of this trip were: 1) to gather supplemental socioeconomic information and 2) to carry out a public consultation and information program. This program consisted of a series of public meetings to present the project from the technical, financial, and environmental perspectives, and to gather public concerns regarding anticipated project impacts and mitigation programs.

- Preparation of an environmental baseline conditions description. The physical and biological environments were analyzed in order to establish a reference basis to identify and evaluate the potential impacts and to develop the environmental management plan.

The environmental baseline included the following:

- Climate and air quality;
  - Geology, Geomorphology, and soils;
  - Hydrology and water quality;
  - Flora and fauna, including environmentally sensitive areas and species of special concern;
  - Land use capacity; current and planned land uses.
- Preparation of a socioeconomic baseline conditions description. The socioeconomic environment was analyzed in order to evaluate potential impacts and develop the environmental management plan. Specifically, the topics described in the socioeconomic baseline section include the following:
    - Socioeconomic conditions
    - Archeological, historical, and culturally sensitive resources
  - Development of a Cartographic and Geographic Information System (GIS) database that can be used by the project sponsors to plan, track, evaluate, and report the progress of environmental measures during construction and operation of the project. The development of thematic maps and the GIS database included the following steps:
    - Data Review and Assimilation. This task involved: 1) evaluating existing data, 2) designing project geographic data base; and 3) field map production.
    - Database Development. This task comprised: 1) preliminary photographic interpretation and (2) development of the digital GIS database.
    - GIS Products. The following products were prepared: base map, life zones, field maps, land use capacity and planned land use, vegetation, forestry potential, geology, physiography and soils, and hydrology.

- Development of a Public Consultation and Information Program. This program included the preparation of a project brochure and a standard questionnaire to gather information about the various communities. The consultation program included interviews with affected communities, government authorities, NGO's, and other interested parties. The opinions and comments from the different parties were compiled and incorporated into the impact analysis. Public input was then taken into account in the development of the environmental management plan.
- Environmental Sensitivity Analysis. The environmental and socioeconomic characteristics of the study area were assessed and categorized in terms of their sensitivity to the proposed project activities.
- Identification and evaluation of environmental impacts. The analysis of impacts was conducted by superimposing the project description on the baseline conditions. The impact analysis considered the following parameters:
  - Air Quality and Meteorology
  - Geology and Soils
  - Water Resources
  - Biological Resources
  - Socioeconomic issues, and
  - Historical and Cultural Resources.
- Development of an Environmental Management Program. The preparation of the Environmental Management Program followed the analysis sequence of avoidance-minimization-mitigation and includes measures to minimize and control construction and operation impacts.

## 1.4 REPORT STRUCTURE

The EIS report consists of the following sections:

- **Executive Summary.** This section summarizes the study and highlights the main characteristics of the project.
- **Chapter 1: Introduction.** This chapter describes the study's background, objectives, methodology, and lists the professionals who conducted the study.
- **Chapter 2: Environmental Regulatory Framework.** This chapter includes a summary of the Bolivian environmental legislation, as well as international environmental standards of the World Bank/IFC that are relevant to the project.
- **Chapter 3: Project Description.** This chapter describes the project's geographic setting, organization, components, and activities.
- **Chapter 4: Environmental Baseline Conditions.** This chapter describes the physical and biological baseline conditions of the project's area of influence. It also provides an environmental sensitivity analysis of the study area.
- **Chapter 5: Socioeconomic Baseline Conditions.** This chapter describes the socioeconomic baseline conditions of the project's area of influence.
- **Chapter 6: Environmental Impacts.** This chapter identifies and evaluates the potential impacts caused by the construction and operation of the project on the physical, biological, and socioeconomic environment. It also includes a description of the methodology used to evaluate the potential impacts.
- **Chapter 7: Environmental Management Plan.** This chapter presents the Environmental Management Plan (EMP) which has been designed to minimize, mitigate, or compensate potential negative environmental impacts. The EMP discusses actions to be taken to

manage and monitor environmental quality and provides guidelines for erosion control, waste management, environmental training, public involvement and education, health and safety, contingency, abandonment, and environmental inspection.

- **Chapter 8: Public Consultation Program.** This chapter describes the public consultation program completed as part of this study.
- **Chapter 9: Conclusions and Recommendations.** This chapter presents the main conclusions and recommendations associated with the construction and operation of the project from an environmental perspective.
- **Chapter 10: Bibliography.** The final chapter lists the references cited in the text.

## 1.5 PROFESSIONAL STAFF

This study was conducted by a multidisciplinary team of professionals formed by personnel from Dames & Moore and local consultants. The key members of this team are listed below, along with a brief description of their responsibilities in the study.

**Jonathan Motherwell**, Senior Civil, Geotechnical, and Environmental Engineer, with over 19 years of experience. Mr. Motherwell is Dames & Moore's General Manager for Latin America and was responsible for the supervision of all project's operations.

**Carlos Mendez**, Senior Civil, Geotechnical, and Environmental Engineer, with over 15 years of experience. Mr. Mendez was the project manager for the study and directed the administrative and technical operations of the study.

**Beverly F. Birkitt**, Senior Biologist with over 20 years of experience in Ecology, Water Quality, and Environmental Impact Assessments. Ms. Birkitt coordinated the Environmental Impact Analysis and preparation of the Mitigation, Environmental Management and Monitoring Plans.

**Ricardo Calvo, Ph.D.**, Senior Environmental Scientist with over 10 years of experience. Dr. Calvo coordinated the biological and natural resource investigations, led the groundtruthing, field investigation, and prepared the biological baseline, and cooperated in the preparation of Environmental Impact Analysis and Mitigation, Environmental Management, and Monitoring Plans.

**Juan Lince**, Project Civil Engineer, with over 8 years of experience in civil, environmental, and water resources projects. Mr. Lince conducted groundtruthing field investigations and participated in the preparation of the EIS document. He was also responsible for researching, reviewing, and summarizing the Bolivian environmental regulations.

**Paul Smith**, Senior Geologist, with over 15 years of experience in geological, environmental, and petroleum-related projects. Mr. Smith coordinated the geological investigations of the project.

**Joe Kuebler**, Senior Chemical Engineer, with more than 20 years of experience. Mr. Kuebler coordinated the air quality and atmospheric emissions investigations.

**Elizabeth Geurink**, Hydrologist with five years of experience. Ms. Geurink evaluated the hydrologic baseline and impacts.

**Thomas Gunter**, Project Biologist with over 8 years of experience. Assisted in the impacts analysis and development of the EMP.

**Todd Morgan**, Project Engineer with 6 years of experience. Assisted in the analysis of impacts to the air quality.

**Brad Schaaf**, Systems Engineer with over 9 years of experience and Manager of the Geographic Information Systems (GIS) Department of Dames & Moore. Mr. Schaaf supervised the GIS implementation for the project.

**Steve Tata**, Systems Engineer with over 8 years of experience. Mr. Tata coordinated the GIS implementation for the project.



**Janet Donnelly**, Systems Engineer with over 5 years of experience. Ms. Donnelly participated in the GIS implementation for the project.

**Nelson Bustamante**, Environmental Engineer with over 10 years of experience. Mr. Bustamante participated in the report preparation and was responsible for researching, reviewing, and summarizing current World Bank/IFC environmental guidelines for onshore oil and gas development.

**Angela Miller**, Environmental Engineer with more than two years of experience. Ms. Miller participated in the research, review of information, and report preparation effort on the environmental and socioeconomic aspects of the project.

**Monica Danon**, Environmental Engineer with over 8 years of experience. Ms. Danon participated in report preparation for the study.

**Jaime Mendez**, MBA, with over 15 years of experience. Mr. Mendez participated in the development of the public consultation and information program and the research and review of information effort on the environmental and socioeconomic aspects of the project.

**Lisette Canavesi**, Local anthropologist, with over 10 years of experience. Ms. Canavesi directed the socioeconomic studies of the project and participated in the development of the public consultation and information program.

**Jose Mendez**, MBA, with over 8 years of experience. Mr. Mendez participated in the research and review of information on the environmental and socioeconomic aspects of the project.

**Javier Olmedo**, Local economist with over 8 years of experience. Mr. Olmedo participated in the development of the public consultation and information program and report preparation for the study.

**Edwin Saravia**, Local biologist with over 8 years of experience. Mr. Saravia participated in the biological and natural resources investigations and conducted groundtruthing field reconnaissance.

**Alonso Huerta**, Environmental Scientist, with over 10 years of experience. Mr. Huerta participated in the research and review of information on the environmental and socioeconomic aspects of the project. He also assisted in the review of the Bolivian Environmental Regulations.

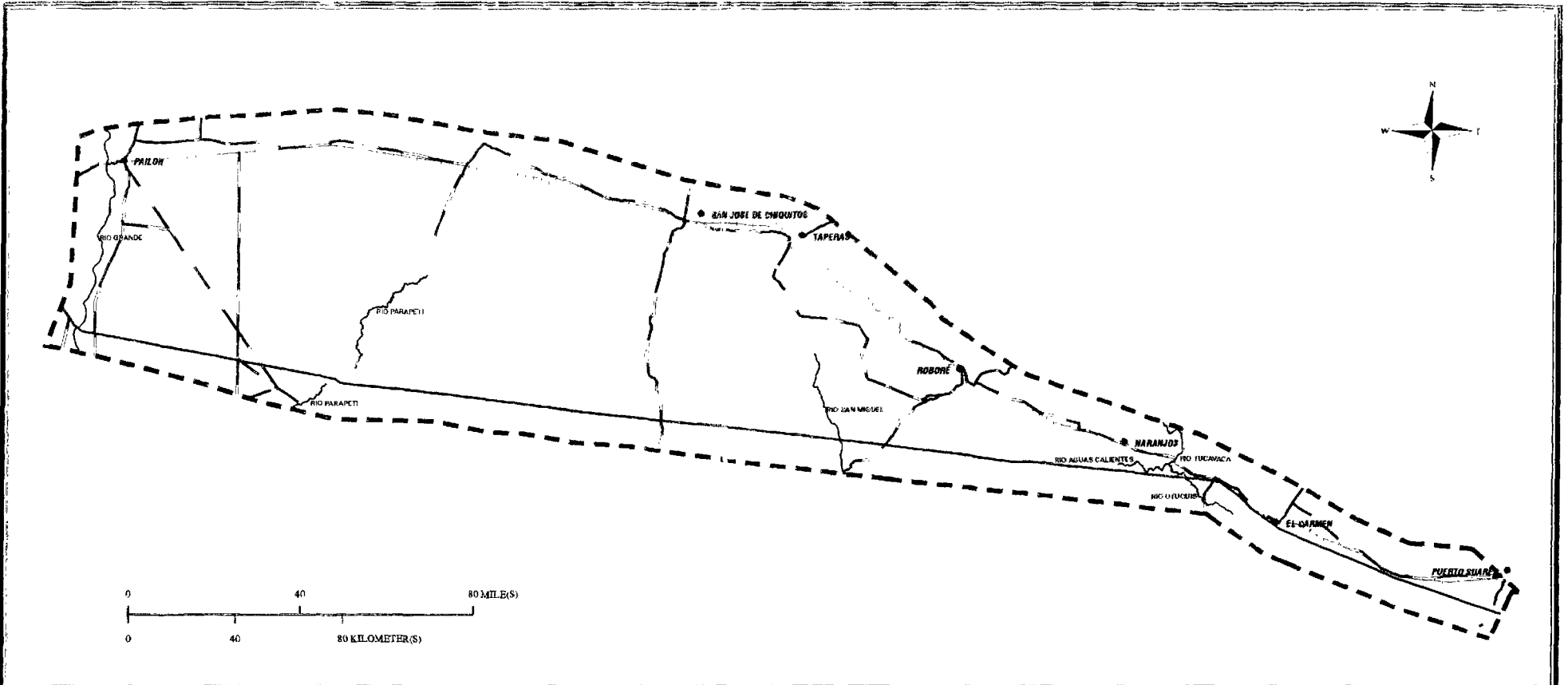

### Legend

- |   |   |
|---|---|
|  Major Roads |  Rivers       |
|  Railroad    |  Gas Pipeline |
|  Study Area  |  Major Towns |

**Bolivia to Brazil Gas Pipeline  
(Bolivian Portion)**

Figure 1.1

**Study Area  
(Project Base Map)**



Reference: Topographic Maps of the Geographic Military Institute (1:250,000)

**CHAPTER 2.0**  
**REGULATORY FRAMEWORK**

**TABLE OF CONTENTS**

2.0	REGULATORY FRAMEWORK .....	2 - 1
2.1	GENERAL .....	2 - 1
2.1.1	Introduction .....	2 - 1
2.1.2	Existing Bolivia-Brazil Gas Pipeline Environmental License .....	2 - 2
2.2	BOLIVIAN ENVIRONMENTAL LAW NO. 1333 .....	2 - 2
2.2.1	Environmental Management Regulation .....	2 - 3
2.2.2	Environmental Prevention and Control Regulation .....	2 - 6
2.2.3	Atmospheric Contamination Regulation .....	2 - 10
2.2.4	Water Contamination Regulation .....	2 - 11
2.2.5	Hazardous Substances Regulation .....	2 - 13
2.2.6	Solid Waste Regulation .....	2 - 14
2.3	THE NEW HYDROCARBON LAW (LAW NO. 1689) .....	2 - 15
2.4	PROPOSED LAW OF INDIGENOUS SETTLEMENTS IN ORIENTE, CHACO, AND THE AMAZONS .....	2 - 18
2.5	PROPOSED LAW OF CONSERVATION OF BIOLOGICAL DIVERSITY .....	2 - 18
2.6	BOLIVIAN REGULATIONS RELATED TO ARCHAEOLOGICAL HERITAGE .....	2 - 20
2.7	LAW OF PUBLIC PARTICIPATION (LAW N°. 1551).....	2 - 21
2.8	ESTABLISHMENT OF THE GRAND CHACO NATIONAL PARK BY SUPREME DECREE NO. 24122 .....	2 - 22
2.9	WORLD BANK/IFC ENVIRONMENTAL GUIDELINES AND POLICIES .....	2 - 23
2.9.1	Legal Framework .....	2 - 23
2.9.2	Environmental Assessment and Review Process .....	2 - 24
2.9.3	World Bank Environmental and Occupational Health and Safety Guidelines .....	2 - 26
2.9.4	World Bank Forest Policy .....	2 - 26

**CHAPTER 2.0**  
**REGULATORY FRAMEWORK**

**TABLE OF CONTENTS**

2.9.5	World Bank Policy on Social Issues . . . . .	2 - 27
2.9.6	World Bank Policy on Economic Analysis . . . . .	2 - 28
2.9.7	World Bank Policy on Interagency Coordination . . . . .	2 - 28
2.9.8	World Bank Policy on Community Involvement . . . . .	2 - 29
2.9.9	World Bank Policy on Air Quality . . . . .	2 - 29
2.9.10	World Bank Policy on Water and Effluent Quality . . . . .	2 - 29
2.9.11	World Bank Policy on Right-Of-Way Alignment . . . . .	2 - 30
2.9.12	World Bank Policy on Ambient Noise . . . . .	2 - 30
2.9.13	World Bank Policy on Solid Wastes and Hazardous Wastes and Materials . . . . .	2 - 30
2.9.14	World Bank Policy on Health and Safety Standards . . . . .	2 - 30
2.9.15	World Bank Policy on Resettlement . . . . .	2 - 31
2.9.16	Other Guidelines Specific to Pipelines Projects . . . . .	2 - 31
2.9.17	Drinking Water . . . . .	2 - 31
2.9.18	Biodiversity Preservation . . . . .	2 - 31

**CHAPTER 2.0  
REGULATORY FRAMEWORK**

**LIST OF TABLES**

<b><u>TABLE NO.</u></b>	<b><u>DESCRIPTION</u></b>
2.1	AIR QUALITY PERMISSIBLE LIMITS FOR SPECIFIC CONTAMINANTS - BOLIVIAN ENVIRONMENTAL LAW NO. 1333
2.2	MAXIMUM PERMISSIBLE PARAMETERS LIMITS FOR RECEIVING BODIES - BOLIVIAN ENVIRONMENTAL LAW NO. 1333
2.3	WORLD BANK AIR QUALITY GUIDELINES
2.4	LIMITS FOR PROCESS WASTEWATER, DOMESTIC SEWAGE AND CONTAMINATED STORM WATER FOR DISCHARGE TO SURFACE WATERS - WORLD BANK/IFC ENVIRONMENTAL GUIDELINES
2.5	RIGHT-OF-WAY ALIGNMENT - WORLD BANK/IFC ENVIRONMENTAL GUIDELINES
2.6	AMBIENT NOISE LEVELS - WORLD BANK/IFC ENVIRONMENTAL GUIDELINES
2.7	SOLID WASTES - WORLD BANK/IFC ENVIRONMENTAL GUIDELINES
2.8	HAZARDOUS MATERIALS AND WASTES - WORLD BANK/IFC ENVIRONMENTAL GUIDELINES

**CHAPTER 2.0**  
**REGULATORY FRAMEWORK**

**LIST OF TABLES**

<b><u>TABLE NO.</u></b>	<b><u>DESCRIPTION</u></b>
2.9	HEALTH & SAFETY GUIDELINES - WORLD BANK/IFC ENVIRONMENTAL GUIDELINES - NATURAL GAS PIPELINE TRANSMISSION SYSTEMS
2.10	RESETTLEMENT - WORLD BANK ENVIRONMENTAL GUIDELINES
2.11	OTHER GUIDELINES SPECIFIC TO PIPELINES - WORLD BANK/IFC ENVIRONMENTAL GUIDELINES

## 2.0 REGULATORY FRAMEWORK

### 2.1 GENERAL

#### 2.1.1 Introduction

This chapter presents the results of a legislative and regulatory review of applicable national and international regulations and guidelines related to construction, implementation, and operation of the proposed gas pipeline project. The Bolivian legislation and international guidelines reviewed as part of this study included the following:

- Bolivian Environmental Law (Law No. 1333),
- Bolivian Hydrocarbon Law (Law No. 1689),
- Proposed Law of Indigenous Settlements in Eastern Bolivia, the Chaco, and the Amazons (proposed by Supreme Decree No. 22612 of October 10, 1990),
- Proposed Law of Conservation of Biological Diversity (proposed by the Bolivian Senate on October 14, 1992),
- Legal regulations related to the Bolivian archeological heritage,
- Bolivian Law of Public Participation (Law No. 1551),
- Supreme Decree No. 24122 of September 21, 1995, giving protection status to over 3.4 million hectares of land and establishing the Grand Chaco National Park and its Integrated Land Use Areas,
- World Bank/IFC Environmental Guidelines.

In recent years, the intensity of international investment in many forms of capital and technology transfer in developing countries has increased significantly. As a result, many Latin American countries, like Bolivia, have already implemented or are in the process of implementing environmental legislation that requires an environmental license prior to the start of construction activities in new projects.

With the implementation of Law No. 1333 in 1992, the environmental regulations in Bolivia have changed substantially. Regulations for this Law were promulgated in late 1995 and are already in effect. The new Hydrocarbons Law was passed in May 1995.



In response to international environmental movements, finance institutions such as the World Bank, have assembled their own environmental guidelines and policies to ensure their investments do not contribute to the detriment of the host country's environment. These guidelines and policies are often applied as environmental standards by investment enterprises and firms in lieu of, or in combination with, the host country's environmental legislation.

### **2.1.2 Existing Bolivia-Brazil Gas Pipeline Environmental License**

Ministerial Resolution No. 259 of 1991, dated September 20, 1991, approved the previous Environmental Impact Study (EIS) of March 1990 completed by El Centro de Investigaciones y Estudio de la Capacidad de Uso Mayor de la Tierra (CUMAT) for the Bolivia-Brazil Gas Pipeline Project and the Puerto Suárez Thermoelectric Plant. The Resolution established that the environmental offices of YPFB and ENDE (Electricity National Company) shall guarantee before the General Secretariat of the Environment (SEGMA) compliance with the conditions established in the Environmental License issued by SEGMA on June 24, 1991. The responsibility to monitor compliance with such conditions are also given to SEGMA.

The original Environmental License for the project was approved based upon the Environmental Impact Study performed by CUMAT. The Ministerial Resolution does not refer to a validity period for the license. However, under the new Environmental Law in Bolivia, if a project does not commence activity within a period of 12 months from issuance of the license, the license must be renewed. Because the scope of the project has changed since the approval of the original environmental license, the license renewal request will be filed by the Project Sponsors along with a copy of the updated EIS.

## **2.2 BOLIVIAN ENVIRONMENTAL LAW NO. 1333**

The Bolivian Sustainable Development and Environmental Ministry (Ministerio de Desarrollo Sostenible y Medio Ambiente - MDSMA), created in October 12, 1993, has recently enacted environmental regulations associated with Law No. 1333. In addition, the Subsecretariat of the Environment (Subsecretaria del Medio Ambiente) was created to monitor compliance with the new regulations and environmental legislation. This Subsecretariat has already established the

technical and administrative procedures of environmental impact evaluations through its two subdivisions: Environmental Impact Evaluation and Environmental Quality Control.

The Law No. 1333 is implemented by six (6) environmental regulations. These regulations address the following issues:

- Environmental Management (Reglamento General de Gestión Ambiental)
- Environmental Prevention and Control (Reglamento de Prevención y Control Ambiental)
- Atmospheric Contamination (Reglamento de Contaminación Atmosférica)
- Water Contamination (Reglamento de Contaminación Hídrica)
- Hazardous Substance (Reglamento para Actividades con Sustancias Peligrosas)
- Solid Waste (Reglamento de Gestión de Residuos Sólidos).

These regulations are described below along with a description of their relevance to the proposed project.

### **2.2.1 Environmental Management Regulation**

This regulation describes environmental policies, environmental planning, and legislative and administrative norms and regulations. It also describes the institutional framework of the environmental authorities, setting up the hierarchy and establishing functions and limitations of each one and the management of environmental information, environmental planning, citizen participation, and environmental control procedures. It also establishes rules and economic instruments for environmental management, and administrative sanctions for environmental violations. The different aspects addressed by this regulation are summarized below.

- Three levels of environmental authorities have been established. These authorities have similar functions, but differ in their respective jurisdiction. These are:
  - The Sustainable Development and Environmental Ministry (MDSMA);
  - The Governor's Office (Prefectura); and,
  - The Municipal Governments (municipalities).

MDSMA has jurisdiction at the national and international level, while the Prefectura and the Municipalities function at the departmental and local level, respectively.

- The institution responsible for the financial, administration, and implementation aspects of the national plans, programs and projects proposed by MDSMA or the Prefectura is the Environmental National Fund (FONAMA). FONAMA also assists in the procurement of financing programs.
- The National Development Council (CODENA), which is under the jurisdiction of the MDSMA, coordinates environmental policy and projects at the intersectorial, or related governmental office level. The Municipalities are responsible for coordinating the dispositions and decisions established by CODENA, and with sectorial organizations within their territorial jurisdiction.
- Reports of Non-Compliance can be filed by any citizen, organization or legally established entity. Reports should include the identity of the source subject (if known), and the unfulfilled current environmental norms, if possible. However, any citizen, organization or legally established entity that files a Report of Non-Compliance will be responsible for the civil and penal damages that the Report may cause to a third party.
- All levels of environmental authorities are required to disclose environmental information to the general public. Such information may be obtained by submitting a written request, with the exception of information considered to be a state or national defense secret. Information involving the private lives of people, medical or forensic reports, and commercial or industrial secrets will not be released to the general public.
- The MDSMA is required to formulate an integral National Environmental Management Plan involving all interested public and private sectors. The Prefectura is responsible for the plan implementation. The municipalities are responsible for promotion, formulation and execution of the plan.
- Direct regulatory instruments include the Environmental Card (Ficha Ambiental), the Environmental Impact Declaration, the Environmental Manifest, Environmental Audits,

the Environmental License and the Environmental Permit. These instruments are described as follows:

- **The Environmental Card (Ficha Ambiental, FA):** A sworn declaration that identifies key project impacts and its possible solutions. This document must be presented to the environmental authority during the phase prior to project execution in order to obtain a project classification (see below).
  
- **The Environmental Impact Declaration (Declaratoria de Impacto Ambiental, DIA):** A document written by the environmental authorities addressing the convenience or inconvenience of a project. If the project is approved, the DIA may include specific conditions to be met by the project. The procedures for the DIA are established in the Environmental Prevention and Control Regulation.
  
- **The Environmental Manifest (Manifiesto Ambiental, MA):** A sworn declaration by which the environmental status of a project is identified, and an Adequation Plan is proposed when needed. The MA must be presented during the implementation, operation or abandonment process of the project. Since the MA is in the category of a sworn declaration, its Adequation Plan may be approved or modified after negotiations between the authority and the proponent.
  
- **The Environmental Audit (Auditoría Ambiental , AA):** A simple study to verify the level of compliance with legal requirements, established internal policies and/or accepted practices. This Audit is prepared when requested by the environmental authority or through the initiative of the company. It can be implemented at any stage of the project.
  
- **The Environmental License (Licencia Ambiental, LA):** An administrative document granted by the environmental authority which endorses the compliance with all anticipated requirements. The DIA constitutes the necessary environmental license to initiate or to continue a project.

- **The Environmental Permit:** A temporary permit of a special nature granted for the generation, elimination, treatment, discharge and final disposal of hazardous substances, residues, wastes, and/or contaminants.
- Economic instruments established in Law No. 1333 include the following:
  - **Effluent or emission charges:** fees for specific contaminant discharges or for defined effects in any medium.
  - **Product charges:** fees on environmentally harmful products when they are used or stored in large quantities.
  - **Charges for the use of public environmental services:** fees for the use of environmental infrastructure, equipment, installations or public information.
  - **Negotiable permits:** emission rights represented by emission quotas. These permits are issued by the environmental authority.
  - **Environmental insurance:** damage coverage for environmental risk, offered by insurance companies through payment of a premium.
  - **Reimbursable deposits:** additional reimbursable payments that are returned once wastes are eliminated.
  - **Guarantee tickets:** anticipated payments made before the implementation of a potentially contaminating activity that are reimbursable once appropriate measures to prevent environmental deterioration are taken.

### **2.2.2 Environmental Prevention and Control Regulation**

This regulation establishes environmental impact evaluation and environmental quality control procedures for performing, evaluating and implementing studies, evaluation category identification, and project inspection and supervision. It describes the technical and administrative

procedures for environmental quality control and administrative sanctions for non-compliance status. It provides appeal procedures, regulates citizen participation, and defines the functions of the environmental authorities regarding environmental impact evaluations. The different aspects addressed by this regulation are summarized below.

- Every person must inform the environmental authority when their activities affect or can affect the environment, or when an environmental accident or incident occurs. All scientific and technical information required for the activities performed must be provided to the environmental authority. An internal self-control registry must be kept and submitted to the environmental authority when required. The environmental authority can request this information, when it deems the activities being performed may cause environmental impacts.
- Projects are classified as National, Departmental or Local based on the geographic location of the activity and the geographic extent of the impacts. The specific characteristics of each classification are presented as follows:
  - **National Projects:** Activities or impacts extending beyond a department or a border, performed within protected areas or dampening zones, or regulated through the Sectorial Regulation System.
  - **Departmental Projects:** Activity or impacts encompassing more than one municipality, located in forest reserves, or not under the responsibility of the National Authority.
  - **Municipal Projects:** Activity or impacts that are limited to one municipality.

This classification defines the level of the environmental authority required for the project. However, the Sustainable Development and Environmental Ministry remains as the top environmental authority responsible for approving, rejecting, or requesting report updates, after the Prefectures and Municipalities have reviewed the Environmental Card, the Environmental Impact Assessment Studies and the Environmental Manifest and released their reports.

- Development projects are classified in four categories which define the project requirements with respect to the Environmental Card and the EIS. The project categories established in this regulation are:
  - **Category 1.-** If the project is classified as Category 1, it will require an Integral Analytical EIS, which will have to be presented within 12 months after the category notification date. This study will require detailed studies of all environmental systems factors (physical, biological, socioeconomic, cultural, legal, and institutional).
  - **Category 2.-** If the project is classified as Category 2, it will require a Specific Analytical EIS, which will have to be presented within twelve 12 months of the notification date. This study must consider the same factors as Category 1, but it will be enough to perform a detailed analysis of one or more environmental factors (physical, biological, socioeconomic, cultural, legal, and institutional), and a general analysis of the remaining factors. The methodology is the same as for Category 1.
  - **Category 3.-** If the project is classified as Category 3, implementation of mitigation measures from the Mitigation Measures Application Plan and the Environmental Monitoring Plan will be required. This document must be presented within six (6) months from the first working day following the project category notification date.
  - **Category 4.-** Projects that belong to this category are those that do not require an EIS, mitigation measures planning, or the development of an environmental monitoring and application plan. If the project is classified as Category 4, the Environmental Subsecretariat or the environmental entity under the Prefect's Office will issue the Dispensation Certificate within ten working days from the first working day following the category notification date.
- The Environmental Card must be prepared using the Environmental Impact Evaluation Computerized procedure which constitutes the technical instrument for establishing the

category of a given project. The environmental authority is required to respond with the project category report within ten working days from the date of filing unless clarifications, updating, or amendments are required. Upon submittal of the supplementary information, the environmental authority has ten working days from the submittal date of such clarifications to respond with the project category report. If it is determined that the FA requires further clarifications, updating, or amendments, all responses will be reported to the project's Legal Representative at one time within ten working days from the date of the categorization report's submittal. Once the information of the FA is clarified, supplemented, or amended, the environmental authority will issue the categorization within five working days from the submittal date of such clarifications.

- The EIS report must be submitted in five copies, along with an EIS presentation form, by the Project Legal Representative. The environmental authorities have a review period of 30 working days for Integral Analytical EISs and 20 working days for Specific Analytical EISs from the submittal date of the clarifications, updates, or amendments. Once the information of the EIS is clarified, complemented, or amended, the environmental authority will issue the Environmental Impact Declaratory (DIA) within thirty working days from the last submittal date.
- Upon approval of the EIS, the environmental authority will issue a DIA, which will constitute the environmental license of the project, work, or activity. This document will determine the environmental conditions with which the project must comply. If an EIS is rejected, the petitioner can proceed to file an appeal with the MDSMA within five working days from the legal notification of rejection. Decisions made at the MDSMA level will exhaust the administrative recourse.
- If the project is delayed or withdrawn during the implementation phase, the corresponding environmental application and monitoring plans, and the mitigation measures stipulated for the project must still be implemented. If the project is delayed for more than 12 months in the implementation stage, a report presenting an analysis of the environmental conditions must be submitted to the environmental authority once the project is reactivated. In such a case, the environmental application, monitoring plan, and mitigation measures



may require modification. The environmental authority will analyze these documents and issue an "Updated DIA".

- The Environmental Application and Monitoring Plan will specify the inspection procedures and period of monitoring during the project implementation, operation, and abandonment phases. The compliance control of the recommendations established in the DIA will be the responsibility of the environmental authorities at the Prefectura and Municipality levels. If during the monitoring, a determination is made that the mitigation measures adopted in the EIS are inefficient or insufficient, adjustments, updating or improvements to the Prevention and Mitigation Program will be the responsibility of the project sponsors.
- Environmental quality control instruments are established for the implementation, operation, maintenance, or abandonment processes for every work activity or project. Such instruments are determined based on the Environmental Manifest which has been designed as the legal technical instrument reflecting the current environmental status for the purpose of establishing the Environmental Adequation Plan.
- The objective of the environmental audit is to define basic conditions and to verify the level of compliance of the existing environmental norms during the operation phase of a project and at the end of the project's useful life.
- The environmental authorities will be responsible for monitoring the implementation of the environmental conditions stipulated in the DIA.

### **2.2.3 Atmospheric Contamination Regulation**

This regulation establishes procedures for control of atmospheric contamination related to mobile and stationary sources and administrative sanctions for violations related to air quality and atmospheric contamination. It also presents the limits governing both dispersed ground-level pollutant concentrations and in-stack emissions associated with various types of industrial developments. These guidelines vary according to the type of industrial development under consideration. Ambient air quality standards for nitrogen dioxide (NO<sub>2</sub>), carbon monoxide (CO),

and particulate matter less than 10 microns (PM<sub>10</sub>) are presented in Table 2.1. In-stack emission limits for nitrogen dioxide (NO<sub>2</sub>), carbon monoxide (CO), particulate matter less than 10 microns (PM<sub>10</sub>), and sulfur dioxide (SO<sub>2</sub>) are also presented in Table 2.1.

Other aspects addressed by this regulation are summarized as follows:

- Open air incineration or combustion without contamination control equipment for substances and/or materials such as tires, oils and others is prohibited.
- All operators of stationary air sources should:
  - Have contaminant emissions control systems and measures
  - Have monitoring programs
  - Route all emissions by means of ducts and/or stacks
  - Present an Emissions Inventory to the environmental authority
  - Conduct perimeter monitoring if the stationary source is located in an urban zone, is adjacent to protected areas, or can cause negative air quality impacts due to its operational characteristics
  - Keep a record of process and control equipment operation and maintenance
  - Develop a scheduled program of measures to obtain compatible emission levels when permissible limits established are exceeded
  - Inform the pertinent municipality immediately in the event of a contamination control equipment failure

#### **2.2.4 Water Contamination Regulation**

This regulation establishes procedures for water contamination prevention and control applicable to all activities that have the potential of degrading the quality of water resources and describes the administrative sanctions for violations related to water contamination. It also presents the limits established by the Law No. 1333 for liquid effluent contamination and establishes procedures for water quality inspection, supervision, monitoring, evaluation, prevention, protection, and conservation. The allowable limits of contamination related to water quality are presented in Table 2.2.

Other aspects addressed in the water contamination regulation are summarized as follows:

- Water bodies are classified in the following four classes according to use:

**CLASS "A"** - Natural water of maximum or sufficient quality for human consumption without any treatment, or with a simple bacteriological disinfection.

**CLASS "B"** - General utility water requiring physical treatment and bacteriological disinfection in order to be fit for human consumption.

**CLASS "C"**- General utility water requiring complete physical-chemical treatment and bacteriological disinfection in order to be of sufficient quality for human consumption.

**CLASS "D"** - Minimum quality water requiring pre-sedimentation, complete physical-chemical treatment and bacteriological disinfection in order to be fit for human consumption.

- The limits of up to 20 of the contaminants listed in Table 2.2 may be exceeded by as much as 50%. However, none of the Basic Parameters listed in Article 6 of this regulation can be exceeded.
- The authorization to discharge effluents into water bodies will be included in the DIA and the Dispensation Certificate. Submittal of a water quality characterization report is required semi-annually. This report must be prepared by an authorized laboratory addressing both non-treated and treated wastewater.
- Wastewater effluent which characteristics does not satisfy the quality limits defined in the receiving water's classification, should be treated in such way that, once diluted, will satisfy the required standards.
- The MDSMA will establish a special protection regime for wetlands to guarantee their conservation, and ecological and landscape functions.

- Extraction and recharge of groundwater for human consumption will require a DIA in the following cases:
  - The project includes solid, liquid or gaseous wastes that can contaminate groundwater or aquifers through infiltration;
  - Treated effluent injection capable of surpassing the natural aquifer recharge;
  - Irrigation projects where infiltration levels can affect the water table generating flooding or soil salinization;
  - Drilling of wells in zones where contact with salt water exists; and
  - Any activity considered dangerous by the MDSMA.
- The direct recharge or injection of non-treated or treated wastewater should comply with the maximum permitted limits for the aquifer class.
- The maximum flow of non-treated instantaneous discharges must be less than or equal to one third (1/3) of the flow of the river or receiving water bodies at all times.

### 2.2.5 Hazardous Substances Regulation

This regulation establishes procedures related to the use of hazardous substances through the analysis, validation, and reduction of risk, and describes the administrative sanctions for violations related to the misuse of hazardous substances. It also establishes technical and administrative procedures for registering and acquiring licenses and regulates hazardous substance activities, including management, generation, optimization, recycling, selection, recollection, transport, storage, treatment, and confinement. Functions of the environmental authorities regarding hazardous substance activities are also defined in this regulation.

Other aspects addressed in the hazardous waste regulation are summarized as follows:

- Hazardous substances are defined as those that have: corrosivity, explosivity, flammability, pathogenic or biohazard, radioactivity, reactivity, or toxicity in accordance with standard tests. Chemical, biological or other products that have expiration dates and

have not undergone rehabilitation or regeneration processes are also considered hazardous.

- Activities that involve the use of hazardous substances require registration and licensing for hazardous substances activities.
- A Transportation Manifest is required to transport hazardous substances within or outside the country. This manifest should be submitted within seven working days before the shipping date.
- Any treatment process of hazardous substances should preferably be carried out at the place of generation. The construction and operation of treatment plants or the confinement of hazardous substances or their wastes requires an EIS.

#### **2.2.6 Solid Waste Regulation**

This regulation establishes procedures for activities related to solid waste generation, storage, transportation, treatment, and disposal, and adopts a solid waste classification system named the Solid Residues Basic Classification Regarding Origin and Nature. Other aspects addressed in the water contamination regulation are summarized as follows:

- The solid waste generator should deposit residues in containers described by the Regulation in correspondence with technical norms; and store residues within the limits of the property in authorized areas.
- The areas used to store solid waste should be ventilated and preferably protected from rain.
- The transport of solid waste may be conducted within the national territory through any road. The vehicles designated for the solid waste transportation should be exclusively used for this purpose and should be equipped as established in the regulation.
- Treatment of solid wastes shall comply with the requirements set forth for installation and operation of treatment plants. Incineration plants shall comply with the requirements presented in the regulation.

- The final disposal of solid wastes that are not recyclable, should be conducted so as to avoid adverse effects on soils, vegetation and fauna, landscaping, and air and water quality. The operation of disposal areas for solid waste residues shall comply with sanitary landfills methods.

### **2.3 THE NEW HYDROCARBON LAW (LAW NO. 1689)**

A new Hydrocarbon Law was approved by the Bolivian Senate on April 19, 1996 and by the House of Representatives on April 29, 1996. The new Hydrocarbon Law, Law No. 1689 was signed in May of 1996. It should be noted, however, that at the time of this writing, environmental regulations necessary to enforce the new Hydrocarbon Law have not yet been promulgated. This section presents a summary of the provisions presented in the new Hydrocarbon Law in relation to the transportation of natural gas.

The Bolivian Constitution establishes that all hydrocarbon deposits belong to the State and that no concession or contracts may be granted to transfer the ownership of such deposits to other parties. The right to explore and exploit hydrocarbon deposits and to commercialize petroleum products has been given to the State national oil company Yacimientos Petrolíferos Fiscales Bolivianos (YPFB). YPFB is allowed to hold shared risk and limited period contracts with individual or collective, national or foreign entities, to explore, exploit, and market hydrocarbons. The transport of hydrocarbons through pipelines will be the object of administrative concession to be given by the Superintendence of Hydrocarbons of the Sectoral Regulation System (SIRESE) (Article 1).

The new Hydrocarbon Law classifies the petroleum activities as Exploration, Exploitation, Commercialization, Transportation, Refining and industrialization, and Distribution of natural gas by networks (Article 9). The activities related to exploration, exploitation, transportation, and distribution of natural gas by networks are considered as national projects, of public good nature, and are under the protection of the State.

The Law establishes that any individual or collective, national or foreign person may construct and operate pipelines for hydrocarbon transportation or the distribution of natural gas by first obtaining an administrative concession granted by the SIRESE (Article 33). The tariffs for the

transportation of hydrocarbons by pipelines must be approved by SIRESE under the following principles (Article 34):

- To ensure the lowest cost to the users of the hydrocarbon transportation system and natural gas distribution through pipelines;
- To allow the concessionaires, under a rational and prudent administration, to receive the sufficient revenues to cover all the operating costs, taxes (with the exception of the tax on income abroad, depreciations, and financial costs, and to obtain adequate and reasonable return; and,
- To encourage the concessionaires to improve the efficiency of their operations.

The responsibility of supervising and inspecting the concessionaires is given to SIRESE. During the period of concession for hydrocarbons transportation by pipelines, the concessionaire may not discontinue the services under his responsibility without previous authorization by SIRESE, except in cases of unexpected occurrence (Articles 35).

SIRESE is given the authority to grant concessions for the construction and operation of pipelines for hydrocarbon transportation. Such concessions are conditioned to the fulfillment of execution periods, economic, safety and environmental protection regulations (Article 36).

Transportation of hydrocarbons by pipelines is governed by the principle of free access, which gives every person the right to access to a pipeline to the extent as long as an available capacity exists (Article 37). Denial of access to pipelines is considered by SIRESE to be abusive practice (Article 38).

Concessionaires of hydrocarbons transportation by pipeline are not allowed to distribute natural gas by networks, buy or sell natural gas, or participate in electricity production. Exceptions to this rule exist if the project or operation is isolated, if it can not be financed or profitable, or of importance to emerging domestic markets of natural gas (Article 40).

YPFB or its joint venture partners in projects involving exploration, exploitation and/or commercialization of hydrocarbons and concessionaires involved in transportation of hydrocarbons by pipelines can request to the National Secretary of Energy, the expropriation of land required for the construction of essential buildings and installations, subject to payment of fair compensation (Article 53). The party benefiting with the expropriation is required to pay the established compensation within a period of 90 days from the date of the corresponding resolution (Article 61).

The land owner will recover partially or totally the previously expropriated land when all or part of this land is not used for the expropriation use. The land may also be recovered when the property has not been used within a period of five years from the date of the beginning of the expropriation process (Article 62). The expropriation may not include houses, cemeteries, roads, railroads, airports and any other stable and permanent construction (Article 63).

YPFB or its joint venture partners in projects involving exploration, exploitation and/or commercialization of hydrocarbons and concessionaires involved in any petroleum activity as defined in Article 9, can request the establishment of easements ("servidumbres") in any private or public surface area, with the exception of the cases presented in Article 63. Easements may be requested from the National Secretary of Energy. The expenses incurred in the establishment of the easements will be paid by the interested party (Article 64).

All petroleum activities are subject to regulation of the SIRESE, specifically Law No. 1600 of October 28, 1994 (Article 65).

The concessions subject to this Law can be declared as canceled or revoked by SIRESE based on the following (Article 67):

- when the concessionaire does not meet the time frame specified in the concession agreement.
- when the concessionaire does not take corrective action after being notified of non-compliance with the obligations established in the concession agreement.



- when the concessionaire fails to allow open access to the use of his pipelines.
- when the concessionaire declares bankruptcy.

#### **2.4 PROPOSED LAW OF INDIGENOUS SETTLEMENTS IN ORIENTE, CHACO, AND THE AMAZONS**

The application of an Indigenous Settlements Law is currently pending in Bolivia. On October 10, 1990, a draft Law was proposed by Supreme Decree No. 22612 to recognize and guarantee the indigenous peoples their social and community property within their territories, and to grant them the rights for the rational use and administration of the land and its natural renewable resources. This proposal also gave preferential treatment to the indigenous peoples for the exploitation of non-renewable natural resources. The proposed Law would have required the State to consult with the indigenous peoples prior to authorizing the exploitation and use (by third parties) of non-renewable natural resources located within their territories. However, the Law has not been passed to date and thus it has no effect on the implementation of the proposed gas pipeline project.

#### **2.5 PROPOSED LAW OF CONSERVATION OF BIOLOGICAL DIVERSITY**

A proposed Law of Conservation of Biological Diversity was introduced on October 14, 1992 to provide legislation on the conservation and use of the biological resources of Bolivia. This law proposal intended to promote and regulate the sustainable use of the biologic resources. The Law has not been passed to date and thus it has no effect on the implementation of the proposed pipeline project. However, a summary of its content is presented below for information purposes:

- It explains the general objectives of the law and defines the fundamental concepts of biological diversity as "the variability of living organisms within each species, between the species and the terrestrial and aquatic ecosystems".
- It provides the institutional framework, the attributes of the National Secretariat of the Environment (Secretaría Nacional del Medio Ambiente [SENMA]) and Ministry of Agricultural Affairs (Ministerio de Asuntos Campesinos Agropecuarios [MACA]) in

relation to biological diversity, provides the basis for the administration of biological diversity, and administration and management of protected natural areas.

- It defines and describes the ecosystems and the ecological process, the sustainable use of the biological resources, and provides the norms for the exploitation of the biological resources and indicates that future regulations will specify the rules and control mechanisms.
- It addresses the characteristics and objectives of protected natural areas, describes the National System of Protected Natural Areas or Sistema Nacional de Areas Naturales Protegidas (SNANP), and the Departmental System of Natural Areas Protected or Sistema Departamental de Areas Naturales Protegidas (SDANP). It also defines the different categories of the protected natural areas and administration and interaction of the population and the protected natural areas.
- It provides the priorities of scientific investigations, and the characteristics of the agreements between interinstitutional investigations.
- It describes the mechanisms and the designated institutions to coordinate the investment, financing and incentives to promote the sustainable use of biological resources. Title VI also describes implementation of plans that use adequate technologies to increase the productivity of biological resources.
- It addresses international agreements, vigilance and administrative violations. The procedures for administrative violations are also described.
- It explains transgressions or crimes other than the laws included in Articles 103 through 114 of the General Environmental Law (Ley General del Medio Ambiente). The commercialization of wildlife species in jeopardy of extinction is considered criminal, whether performed in the internal or external market. Sanctions are stipulated for persons that collect jeopardized species or their eggs, or destroy nests or shelters occupied by wildlife animals.

## 2.6 BOLIVIAN REGULATIONS RELATED TO ARCHAEOLOGICAL HERITAGE

The legal requirements for the defense of the Bolivian Archeological heritage are summarized in the publication titled "Disposiciones Legales Sobre la Defensa del Patrimonio Arqueológico Boliviano" which was prepared by the Universidad Técnica de Oruro in 1985. A summary of the legal requirements included in this publication is as follows:

- **Supreme Decree No. 12638 of June 19, 1975**, establishes that the National Institute of Archaeology is the official institution representing the State in issues related to the exploration, excavation, restoration, and conservation of archaeological artifacts existing within the limits of the Republic of Bolivia.
- **Supreme Decree No. 15900 of October 1, 1973**, establishes that the destruction, damage, removal, or exploitation of cultural goods belonging to the State are subject to the penalties stipulated in the Penal Code (Article 3).
- **The Bolivian Penal Code of August 23, 1972** declares that whomever destroys, damages, removes, or exports monuments or objects from the archaeological heritage will face imprisonment from one to six years (Article 223).
- **The Bolivian Political Constitution of February 2, 1967** indicates that archeological monuments and objects are property of the State, considered "Cultural Treasure", protected by the State, and that exportation is prohibited (Article 191).
- **Supreme Decree No. 07234 of June 30, 1965**, states that the archeological monuments or deposits, as well as the objects encountered in ruins and excavations are declared property of the State. Authorization granted by the Ministry of Education and Culture, must be obtained prior to archaeological excavation activity (Article 1). This Decree also establishes that persons encountering archeological artifacts are required to present them to the nearest authority within jurisdiction; the authority will then remit the artifacts to the Archeological National Institute (Article 2).

- **The Archaeological Excavation Regulation of January 6, 1958**, establishes that no person or entity can carry out archaeological excavations without a formal authorization from the Archaeological Department of the Ministry of Education and Culture (Article 1). This Regulation also states that any authority, official, subcontractor, and natural and legal person that carries out excavations for construction works, mining explorations, opening of access roads and other similar activities is obligated to report to the Department of Archaeology the discovery of any object, piece, and ruin of prehispanic nature encountered during the excavation activity and to secure and preserve the objects until the commissioners take charge of the discovery (Article 52).

The Department of Archaeology will immediately order a technical reconnaissance in order to define the importance or merit of the discovery (Article 53). If the Department fails to order a reconnaissance within a period of one month, the responsible person of the work activities will draw up a certificate (with the intervention of a local authority) that will record the discoveries, and specifications and conditions of the objects encountered. Then, the responsibility of the authority, official, subcontractor, and natural and legal person that ordered the excavation will cease (Article 54).

## **2.7 LAW OF PUBLIC PARTICIPATION (LAW N°. 1551)**

The Community Participation Law (No. 1551) and associated regulations (Decree No. 23813) were passed on April 20, 1994 and June 30, 1994, respectively. The objective of this Law was to recognize, promote and consolidate the process of public participation by incorporating the indigenous, peasant, and urban communities into the judicial, political and economic processes of the country. The Law was enacted to improve the quality of life of the inhabitants of Bolivia and to achieve a more equitable distribution and a better administration of the country resources (Article 1).

Law 1551 transferred some levels of authority from the central government to the local (municipal) governments. This law transferred the jurisdiction of existing public educational, health, roadways, and irrigation infrastructure to the local municipalities. It establishes the distribution of a portion of tax revenues collected from the central government to the

municipalities based on a fixed amount per capita for the population residing within the boundaries of each municipality.

Law 1551 created the "Organizaciones Territoriales de Base - OTBs" (organizational units that may be formed by any group of people living in a common territory). The OTBs are given the right to propose, control, and supervise the execution of works and the performance of public servants. Among the rights given to these organization are:

- To participate and promote actions related to the management and preservation of the environment and the sustainable development (Article 7.b).
- To represent and obtain modifications to actions, decisions, works, and services rendered by public organisms when these oppose community interests (Article 7.c).

This mandate is supplemented by Article 84 of the Environmental Management Regulation of Law 1333 which indicates that the Municipal governments are responsible for environmental inspection and monitoring within their jurisdictions.

## **2.8 ESTABLISHMENT OF THE GRAND CHACO NATIONAL PARK BY SUPREME DECREE NO. 24122**

Supreme Decree No. 24122, dated September 21, 1995, gives protection status to 3,441,115 ha of land and establishes the Grand Chaco National Park (approximately 2.4 million ha) and its Integrated Management Areas (approximately 1 million ha). The Bolivia-Brazil Gas Pipeline right-of-way represents the border between the National Park and the Integrated Management areas for approximately 75 kilometers. Administration and management of the Park and Management Areas will be the responsibility of a Management Committee, formed by representatives of the local communities and agencies.

The CABI organization was instrumental in establishing the Gran Chaco National Park and Integrated Management Area, which was officially authorized by signing of a Bolivian Presidential Decree in September, 1995. CABI joined forces with the Ayoreo and Chiquitano peoples to design a protected area of the largest remaining ecologically intact Tropical Dry Forest of the

world. The Wildlife Conservation Society and Armobía Foundation provided technical assistance. The criteria used to design the protected area included:

- Distribution of habitat types as well as endangered and threatened species.
- Minimum areas needed to insure the survival of endangered species and maintain ecosystem processes.
- Location of private properties and indigenous peoples' land claims usage
- Presence of natural boundaries.

The area protected by this Decree includes the following sections:

- Over 2.4 million ha for National Park Area to guarantee the conservation of biodiversity, genetic resources, and ecological and evolutionary processes.
- Over 700,000 ha for Izozog Integrated Management Area to protect and use biological resources for the sustainable development of the Izozeño Indian Communities.
- Over 300,000 ha for San Miguel Integrated Management Area to protect and use biological resources for the sustainable development of the Ayoreo Communities.

The Grand Chaco National Park, combined with a neighboring 1.5 million ha of proposed and existing reserves in Paraguay will form one of the largest protected zones in the Americas and contains the highest nonflying mammalian biodiversity on the continent.

## **2.9 WORLD BANK/IFC ENVIRONMENTAL GUIDELINES AND POLICIES**

### **2.9.1 Legal Framework**

Projects funded by the IFC are subject to an environmental review process to "ensure consistency with the spirit and intent of the appropriate World Bank policies and guidelines". All projects must also meet the environmental requirements of the host country; in this case Bolivia. If there are no applicable host country or World Bank standards, the IFC applies "internationally accepted standards" to the project. Where standards differ, generally the project must meet the most stringent requirements.

## 2.9.2 Environmental Assessment and Review Process

The project review process is composed of five sequential steps: project screening, issuance of environmental information requirements, environmental review, consultation and disclosure, and project supervision. The results of the environmental review process form an integral element of the ultimate decision-making process for project funding.

The review process includes initial categorization of all projects into one of four categories (A, B, C, or Financial Intermediary [FI]). Each category is based on the extent of potential impact to the environment. Category A projects are those that carry the most significant potential impacts, and therefore require the preparation of a full environmental assessment (EA). Categories B, C, and FI sequentially reflect projects of decreasing potential environmental impact, and corresponding decreasing amounts of environmental impact information required.

Based on the information presented in the Environment Bulletin (Vol. 7, No.3 1995) of the World Bank's Environmental Department, a full EA report is comprised of the following eight components:

1. An executive summary;
2. A concise project description of the geographic, ecological, and social aspects of the project;
3. Baseline data, including assessment of the study area's dimensions and a description of the physical, biological, and socioeconomic conditions;
4. An impact assessment that identifies and assesses the likely positive and negative impacts of the project;
5. Analysis of alternatives from an environmental perspective;
6. A mitigation or management plan that identifies implementation and operational measures to eliminate, offset, or reduce adverse environmental impacts;
7. An environmental monitoring plan; and,
8. Public consultation with affected groups and NGOs during the scoping and EA review stages

Once the EA draft is complete, the borrower submits it to the Bank for review by environmental specialists. If the EA is satisfactory, the Bank project team can proceed to project appraisal. The borrower is responsible for implementing the project according to agreements from the EA process. The Bank supervises the implementation of environmental aspects as part of the overall project supervision.

In addition, the project is also evaluated by the Bank in terms of compliance with applicable host country requirements, policies and guidelines, and/or internationally accepted standards. Host country regulations specific to the Bolivia-Brazil Pipeline Project are presented in Section 2.2. The following sections present the World Bank Environmental, Health and Safety guidelines that are to be met for new projects (including natural gas pipeline transmission systems) and which include provisions for right-of-way alignment, liquid effluents, stack emissions, ambient noise, solid and liquid wastes, and health and safety procedures.

The Bolivia-Brazil Gas Pipeline Project is classified as a Category A project under both the World Bank and IFC environmental review procedures since it is a project that has the potential for diverse and significant environmental impacts. As such, the project sponsor is required to prepare a detailed EA for the project.

Key environmental issues associated with this type of project that must be addressed in the EA are discussed in two subsections of the World Bank's *Environmental Assessment Source book* (1991a; see "Energy and Industry," Volume III, Chapter 10: Oil and Gas Pipelines; Oil and Gas Development - Onshore, pp. 32-40 and 52-62). The EA also must evaluate the project's compliance with the following appropriate World Bank guidelines and policies, including:

- Environmental Assessment Source book (1991a) and Updates (1993; 1994b)
- Operational Directive 4.01 (Environmental Assessment) (1991b)
- Operational Directive 4.20 (Indigenous Peoples) (1991c)
- Operational Directive 4.30 (Involuntary Resettlement) (1990a)
- Operational Policy Note 11.02 (Wildlands) (1990c)
- Technical Paper No. 55 (Techniques for Assessing Industrial Hazards: A Manual) (1988a)
- Technical Paper No. 80 (Involuntary Resettlement in Development Projects) (1988b)
- The Forest Sector: A World Bank Policy Paper (1991d)



- IFC Environmental Review Procedures and Guidelines for Preparation of an Environmental Analysis and Review Projects (IFC, 1993)

### 2.9.3 World Bank Environmental and Occupational Health and Safety Guidelines

World Bank policy requires that projects must be consistent with all relevant World Bank environmental and occupational health and safety guidelines (World Bank, 1995). Guidelines exist for *Onshore Oil and Gas Development*. These guidelines address topics such as liquid effluents, ambient air, and stack emissions. These topics are discussed in more detail in the following sections. These guidelines relate to design of the pipeline including positive pipe corrosion control measures and programs for periodic inspection and maintenance.

### 2.9.4 World Bank Forest Policy

All relevant projects financed by the World Bank must conform with the spirit and intent of the World Bank Forest Policy Paper (World Bank, 1991d) and adhere to its principles. The Bank will finance sponsors who commit to follow World Bank guidelines and internationally accepted practices aimed at preserving existing primary forests. The World Bank will finance the reforestation of degraded land in connection with industrial projects and will encourage the optimal use of wood resources by supporting secondary industries where the raw material is a waste product of other industrial operations.

World Bank Forest Policy also cites qualifications for financing to include, “. . . measures intended to secure benefits that will accrue partly or entirely outside the country . . . .” (e.g., measures to preserve biological diversity of forests).

The World Bank has two policies directly relevant to biological diversity: preservation of endangered species and critical habitats, and conservation and management of wildlands. The Bank's wildlands strategy includes the preservation of sufficient amounts of representative wildlands and protecting or managing them to sustain their viability as plant and animal habitat.

A number of measures recommended by the World Bank have been incorporated into the gas pipeline project design, including:

- Avoiding impacts to remnant primary moist forest and other sensitive habitats in the project's study area through construction of facilities and associated infrastructure to the extent possible within existing degraded areas.
- Providing buffer zones at water body crossings to minimize impacts to remnant gallery forests.

### **2.9.5 World Bank Policy on Social Issues**

Development projects are intended to modify social and natural environments to create or enhance economic, health, educational, and other benefits that are valued by society. Chapter 3 of the *World Bank Environmental Source book* (1991a; see *Social and Cultural Issues in Environmental Review*, pp. 107–136) makes it clear that the social analysis of a project is not expected to be a complete sociological study nor a social cost/benefit analysis of the project. It should, however, identify social changes, evaluate the social costs of long-term operation of the project, and formulate strategies to achieve desired regional objectives. Specific social issues of concern to the World Bank include:

- Variation within communities in terms of ethnic/tribal groups, occupational groups, socioeconomic stratification, age, and gender
- Control over local resources
- Variation within production systems
- Consultation and participation of government agencies, NGOs active in the study area, and affected communities (Operational Directives 4.01 [1991b] and 14.70 [1989] and environmental review procedures)
- Indigenous peoples (Operational Directive 4.20 [1991c])
- Cultural property including sites, structures, and remains of archaeological, historical, religious, cultural, or aesthetic value (1994b)

- Involuntary resettlement (Operational Directive 4.30 [1990a])
- Secondary or induced growth and development within the study area.

### **2.9.6 World Bank Policy on Economic Analysis**

Given the existing scarcities of financial and human resources in developing countries, the World Bank considers it important to invest limited resources to maximize economic benefits. Sound economic analysis of projects and policies is an important means of making the allocation process more efficient and systematically evaluating choices between competing uses of resources.

As opposed to a purely financial analysis, an economic analysis measures a project's effect on the efficiency and development of the affected regional economy. The Bank, however, understands the difficulty of measuring environmental impacts of a project in environmental terms and subsequently valuing these impacts in monetary terms. The main purpose of an economic analysis is to ascertain whether the project can be expected to create more net benefits than any other mutually exclusive option, including a "no project" alternative.

Incorporation of the effects of environmental degradation into public decision making is an essential step toward achieving economically efficient management of natural resources. An economic analysis of projects and policies can help make investments of scarce resources that contribute most to overall regional objectives.

### **2.9.7 World Bank Policy on Interagency Coordination**

The World Bank indicates that, "Because environmental issues generally involve national, provincial, and local government agencies and cover a broad range of responsibilities, coordination among government agencies is crucial" (see Paragraph 18 of the World Bank Operational Directive 4.01 [1991b]). Coordination of the project is being achieved through a series of meetings with government agencies to identify issues, types of analyses required, sources of relevant expertise, Environmental Assessment (EA) responsibilities and schedule, mitigation measures, and other recommendations.

### 2.9.8 World Bank Policy on Community Involvement

The World Bank expects the borrower to consider the views of affected groups and local NGOs in project design and implementation and in the preparation of EAs. The primary objective of consultation is to identify the issues and concerns of affected groups and interested parties. This EIS for the project is consistent with consultation requirements described in the *Environmental Assessment Source book Update, "Public Involvement in Environmental Assessment: Requirements, Opportunities and Issues"* (World Bank, 1993), and the World Bank and IFC environmental review procedures.

### 2.9.9 World Bank Policy on Air Quality

The World Bank has established air quality guidelines for governing both stack emissions and dispersed ground-level pollutant concentrations associated with various types of industrial developments; these guidelines vary according to the type of industrial development under consideration. The applicable industrial operation for which the World Bank has established guidelines and which would be included in the project is *Onshore Oil and Gas Development* (see World Bank, 1995). Both air pollutant emission and ambient air pollutant concentration guideline values have been promulgated for this type of industrial operation. Table 2-3 summarizes current World Bank ambient air guidelines for particulate matter less than 10 microns (PM<sub>10</sub>), nitrogen dioxide (NO<sub>2</sub>), and sulfur dioxide (SO<sub>2</sub>), and stack emission limits for PM<sub>10</sub>, SO<sub>2</sub>, and NO<sub>2</sub>. Chapter 6 describes potential air quality impacts of the project.

### 2.9.10 World Bank Policy on Water and Effluent Quality

The World Bank's liquid effluent guidelines for process wastewater, domestic sewage, and contaminated storm water are included in Table 2.4. The World Bank's guidelines for *Onshore Oil and Gas Development* are included in Appendix A.

### **2.9.11 World Bank Policy on Right-Of-Way Alignment**

The principal elements of World Bank policy regarding right-of-way alignment, land acquisition, compressor or pumping station siting and creation of access (e.g., roads) in otherwise inaccessible environmentally sensitive areas are summarized in Table 2.5.

### **2.9.12 World Bank Policy on Ambient Noise**

The impact of the noise from the operation of the facility is to be taken into consideration during the design and operation of the facility. Noise levels from the project's operation, measured at noise receptors located outside the project property boundary, should not exceed the limits presented in Table 2.6.

### **2.9.13 World Bank Policy on Solid Wastes and Hazardous Wastes and Materials**

The World Bank/IFC has established solid and hazardous wastes guidelines which are presented in Tables 2.7 and 2.8, respectively.

### **2.9.14 World Bank Policy on Health and Safety Standards**

World Bank criteria for project health and safety aspects include standards for:

- General Safety (e.g., personal protection equipment and measures);
- Electrocutation prevention;
- General health maintenance (e.g., personal hygiene);
- Workplace air quality;
- Workplace noise;
- Work in confined spaces;
- Hazardous material handling and storage;
- Medical surveillance;
- Training; and,
- Record keeping and Reporting.

Specific standards are presented in Table 2.9.

### **2.9.15 World Bank Policy on Resettlement**

World Bank resettlement guidelines are summarized in Table 2.10.

### **2.9.16 Other Guidelines Specific to Pipelines Projects**

Table 2.11 shows other guidelines specific to pipeline transmission projects related to programs of inspection and maintenance and some control measures of the metering system, sensors and the pipeline system in general.

### **2.9.17 Drinking Water**

The guidelines for drinking water quality apply when sponsors are responsible for the project's drinking water supply. Sponsors should use the drinking water standards that are published by the World Health Organization in "*Guidelines for Drinking Water Quality, Health Criteria and the Supporting Information*".

### **2.9.18 Biodiversity Preservation**

The World Bank Policy Paper, Forest Sector, requires the establishment of measures to preserve the biologic diversity of the forest as part of its development. The World Bank has two Policies directly pertaining to biodiversity: the preservation of endangered species and critical habitats and the preservation and management of wildlife areas. The strategy for wildlife areas deals with the preservation of most lands located in wild areas and their protection and management, in order to sustain the viability of plants and animal populations. The biodiversity preservation plans should establish basic guidelines in order to avoid the impacts on primary rain forests and other sensitive habitats in the project area during the construction of facilities and infrastructure. The plan must also take into account the establishment of buffer areas, appropriate corridors for wild animals and other measures that help maintain the integrity of wild areas.

**TABLE 2.1**  
**AIR QUALITY PERMISSIBLE LIMITS FOR SPECIFIC CONTAMINANTS**  
**BOLIVIAN ENVIRONMENTAL LAW No. 1333**

PARAMETER	CONCENTRATION
Carbon Monoxide (CO)	10 mg/m <sup>3</sup> average in 8 hr 40 mg/m <sup>3</sup> media en 1 hr
Sulfur Dioxide (SO <sub>2</sub> )	80 µg/m <sup>3</sup> annual arithmetic average 365 µg/m <sup>3</sup> average in 24 hr
Nitrogen Dioxide (NO <sub>2</sub> )	150 µg/m <sup>3</sup> average in 24 h 75 µg/m <sup>3</sup> average in 1 hr
Total Suspended Particle Matter	260 µg/m <sup>3</sup> average in 24 hr 75 µg/m <sup>3</sup> annual geometric average
Particle Matter less than 10 microns (PM <sub>10</sub> )	150 µg/m <sup>3</sup> average in 24 hr 50 µg/m <sup>3</sup> annual geometric average
Ozone (Oz)	236 µg/m <sup>3</sup> maximum hourly average
Lead	1.5 µg/m <sup>3</sup> quarterly arithmetic average
Arsenic	50 ng/m <sup>3</sup> annual arithmetic average
Cadmium	40 ng/m <sup>3</sup> annual arithmetic average
Manganese	2 µg/m <sup>3</sup> annual arithmetic average
Mercury	1 µg/m <sup>3</sup> annual arithmetic average
Vanadium	0.2 µg/m <sup>3</sup> annual arithmetic average
Zinc	50 µg/m <sup>3</sup> annual arithmetic average
Sulfuric Acid	150 µg/m <sup>3</sup> annual arithmetic average
Fluoride	150 mg/m <sup>3</sup> annual arithmetic average 200 mg/m <sup>3</sup> average in 1/2 hr
Clorhidric Acid	100 µg/m <sup>3</sup> annual arithmetic average
Dichloromethane	1 mg/m <sup>3</sup> average in 24 hr
Trichloroethyl	1 mg/m <sup>3</sup> average in 24 hr
Tetrachloroethyl	5 mg/m <sup>3</sup> average in 24 hr
Estirene	800 µg/m <sup>3</sup> average in 24 hr
Toluene	7.5 mg/m <sup>3</sup> average in 24 hr
Formaldehyde	100 µg/m <sup>3</sup> average in 1/2 hr

TABLE 2.1 AIR QUALITY PERMISSIBLE LIMITS FOR SPECIFIC CONTAMINANTS BOLIVIAN ENVIRONMENTAL LAW No. 1333	
PARAMETER	CONCENTRATION
Carbon Disulfate	100 $\mu\text{g}/\text{m}^3$ average in 24 hr

Source: Atmospheric Contamination Regulation  
Bolivian Environmental Law No. 1333

Units:  $\text{mg}/\text{m}^3$ : milligrams per cubic meter  
 $\mu\text{g}/\text{m}^3$ : micrograms per cubic meter  
 $\text{ng}/\text{m}^3$ : nanogram per cubic meter



**TABLE 2.2**  
**MAXIMUM PERMISSIBLE PARAMETERS LIMITS FOR RECEIVING BODIES**  
**BOLIVIAN ENVIRONMENTAL LAW NO. 1333**

PARAMETERS	CLASS A	CLASS B	CLASS C	CLASS D
pH	6.0-8.5	6.0-9.0	6.0-9.0	6.0-9.0
Temperature °C	+/- 3 °C receptor	+/- 3 °C receptor	+/- 3 °C receptor	+/- 3 °C receptor
Sediment Solids (mg/l)	1,000	1,000	1,500	1,500
Oil and Grease	Absent	Absent	0.3	1
BOD <sub>5</sub> (mg/l)	< 2	< 5	< 20	< 30
QBD (mg/l)	< 5	< 10	< 40	< 60
Colifecal (N/100 ml)	< 50 & < 5 in 80% in samples	< 1,000 and < 200 in 80% of samples	< 5,000 and < 1,000 in 80% of samples	< 5,000 and < 5,000 in 80% of samples
Parasites (N/l)	< 1	< 1	< 1	< 1
Color (mg Pt/l)	< 10	< 50	< 100	< 200
Dissolved Oxygen (mg/l)	> 80% sat.	> 70% sat.	> 60% sat.	> 50% sat.
Turbidity (UNT)	< 10	< 50	< 100	< 200
Settling Solids (mg/l-ml/l)	< 10 mg/l	30 mg/l - 0.1 ml/l	< 50 mg/l - < 1 ml/l	100 - < 1 ml/l
Aluminum (mg/l)	0.2	0.5	1.0	1.0
Ammonia (mg/l)	0.05	1.0	2.0	4.0
Antimony (mg/l)	0.01	0.01	0.01	0.01
Arsenic (total) (mg/l)	0.05	0.05	0.05	0.1
Benzene (µg/l)	2.0	6.0	10.0	10.0
Barium (mg/l)	0.05	1.0	2.0	5.0
Berilium (mg/l)	0.001	0.001	0.001	0.001
Borium (mg/l)	1.0	1.0	1.0	1.0

**TABLE 2.2**  
**MAXIMUM PERMISSIBLE PARAMETERS LIMITS FOR RECEIVING BODIES**  
**BOLIVIAN ENVIRONMENTAL LAW NO. 1333**

PARAMETERS	CLASS A	CLASS B	CLASS C	CLASS D
Calcium (mg/l)	200	300	300	400
Cadmium (mg/l)	0.005	0.005	0.005	0.005
Cyanide (mg/l)	0.02	0.1	0.2	0.2
Chlorine (mg/l)	250	300	400	500
Copper (mg/l)	0.05	1.0	1.0	1.0
Cobalt (mg/l)	0.1	0.2	0.2	0.2
Chromium <sup>6+</sup> (mg/l)	0.05 total	0.05	0.05	0.05
Chromium <sup>3+</sup> (mg/l)	NE	0.6	0.6	1.1
1,2 Dichloroethene (µg/l)	10.0	10.0	10.0	10.0
1,1 Dichloroethane (µg/l)	0.3	0.3	0.3	0.3
Tin (mg/l)	2.0	2.0	2.0	2.0
Phenols (µg/l)	1	1	5	10
Iron (soluble) (mg/l)	0.3	0.3	1.0	1.0
Fluoride (mg/l)	0.6-1.7	0.6-1.7	0.6-1.7	0.6-1.7
Total Phosphate (mg/l)	0.4 Orthophosphate	0.5 Orthophosphate	1.0 Orthophosphate	1.0 Orthophosphate
Magnesium (mg/l)	100	100	150	150
Manganese (mg/l)	0.5	1.0	1.0	1.0
Mercury (mg/l)	0.001	0.001	0.001	0.001
Lithium (mg/l)	2.5	2.5	2.5	5
Nickel (mg/l)	0.05	0.05	0.5	0.5
Nitrate (mg/l)	20.0	50.0	50.0	50.0
Nitrite (mg/l)	< 1.0	1.0	1.0	1.0
Total Nitrogen (mg/l)	5	12	12	12

**TABLE 2.2**  
**MAXIMUM PERMISSIBLE PARAMETERS LIMITS FOR RECEIVING BODIES**  
**BOLIVIAN ENVIRONMENTAL LAW NO. 1333**

PARAMETERS	CLASS A	CLASS B	CLASS C	CLASS D
Lead (mg/l)	0.05	0.05	0.05	0.1
Silver (mg/l)	0.05	0.05	0.05	0.05
Pentachlorophenol (µg/l)	5.0	10.0	10.0	10.0
Selenium (mg/l)	0.01	0.01	0.01	0.05
Sodium (mg/l)	200	200	200	200
Suspended Solids	Absent	Absent	Absent	< ret. sieve 1 mm <sup>2</sup>
Sulfates (mg/l)	300	400	400	400
Sulfurs (mg/l)	0.1	0.1	0.5	1.0
Detergents (mg/l)	0.5	0.5	0.5	0.5
Tetrachloroethene (µg/l)	10	10	10	10
Trichloroethene (µg/l)	30	30	30	30
Carbon Tetrachlorine (µg/l)	3	3	3	3
2,4,6 Trichlorophenol (µg/l)	10	10	10	10
Total Uranium (mg/l)	0.02	0.02	0.02	0.02
Vanadium (mg/l)	0.1	0.1	0.1	0.1
Zinc (mg/l)	0.2	0.2	5.0	5.0
<b>HERBICIDES:</b>				
Aldrin-Dieldrine @ (µg/l)	0.03	0.03	0.03	0.03
Chlordane (µg/l) @	0.3	0.3	0.3	0.3

**TABLE 2.2**  
**MAXIMUM PERMISSIBLE PARAMETERS LIMITS FOR RECEIVING BODIES**  
**BOLIVIAN ENVIRONMENTAL LAW NO. 1333**

PARAMETERS	CLASS A	CLASS B	CLASS C	CLASS D
Dichloro Diphenyl Trichloroethane (D.D.T.) ( $\mu\text{g/l}$ ) @	1.0	1.0	1.0	1.0
Endrina ( $\mu\text{g/l}$ ) @		@	@	@
"Endosulfan" ( $\mu\text{g/l}$ ) @	70	70	70	70
Heptachlorine & heptachlorpoxide ( $\mu\text{g/l}$ ) @	0.1	0.1	0.1	0.1
Lindane ( $\mu\text{g/l}$ ) @	3.0	3.0	3.0	3.0
Methoxychlorine ( $\mu\text{g/l}$ )	30	30	30	30
Polychlorinated Biphenyls ( $\mu\text{g/l}$ )	2.0	NE	NE	NE
PCBs ( $\mu\text{g/l}$ )		0.001	0.001	0.001
"Toxafeno" ( $\mu\text{g/l}$ ) @	0.01	0.01	0.01	0.05
"Demeton" ( $\mu\text{g/l}$ )	0.1	0.1	0.1	0.1
"Gution" ( $\mu\text{g/l}$ )	0.01	0.01	0.01	0.01
Malathion ( $\mu\text{g/l}$ )	0.04	0.04	0.04	0.04
Parathion ( $\mu\text{g/l}$ ) @	@	@	@	@
"Carbaril": Organophosphates Comp. and Total Carbamates ( $\mu\text{g/l}$ )		0.02	0.02	0.02
2,4-D; Herbicide: Chlorophenoxy ( $\mu\text{g/l}$ )	100	100	100	100
2,4,5-TP; Herbicide: Chlorophenox ( $\mu\text{g/l}$ )	10.0	10.0	10.0	10.0
2,4,5-T ( $\mu\text{g/l}$ ) @	2.0	2.0	2.0	2.0

<b>TABLE 2.2</b> <b>MAXIMUM PERMISSIBLE PARAMETERS LIMITS FOR RECEIVING BODIES</b> <b>BOLIVIAN ENVIRONMENTAL LAW NO. 1333</b>				
PARAMETERS	CLASS A	CLASS B	CLASS C	CLASS D
<b>RADIATION:</b>				
Global Alpha (Bq/l)	0.1	0.1	0.1	0.1
Global Beta (Bq/l)	1.0	1.0	1.0	1.0

Notes:

@: Importation of these herbicides is prohibited; however, they continue to be of use  
 NE: Not specified

TABLE 2.3 WORLD BANK AIR QUALITY GUIDELINES <sup>1</sup>	
POLLUTANT AVERAGING PERIOD	ONSHORE OIL AND GAS DEVELOPMENT
<b>Ambient Air:</b> Concentrations of contaminants, measured outside the property boundary, should not exceed the following limits:	
Particulate Matter (< 10 $\mu\text{m}$ diameter)	
Annual Arithmetic Mean	50 $\mu\text{g}/\text{m}^3$
Maximum 24-hour Average	70 $\mu\text{g}/\text{m}^3$
Nitrogen Oxides, as $\text{NO}_2$	
Maximum 24-hour Average	150 $\mu\text{g}/\text{m}^3$
Sulfur Dioxide	
Annual Arithmetic Mean	50 $\mu\text{g}/\text{m}^3$
Maximum 24-hour Average	125 $\mu\text{g}/\text{m}^3$
<b>Stack Emissions:</b> Pollutant emissions from facility stacks should not exceed the following emission limits:	
Particulate Matter	50 $\text{mg}/\text{m}^3$
Sulfur Dioxide	100 tpd
Nitrogen Oxides, as $\text{NO}_2$	
Gaseous fossil fuel	90 g/million Btu of heat input <sup>1</sup>
Liquid fossil fuel	135 g/million Btu of heat input <sup>1</sup>

Source: World Bank Environment, Health and Safety Guidelines, Onshore Oil and Gas Development

<sup>1</sup>Guidelines are applicable to oil-fired boilers and fired heaters but are not applicable to  $\text{NO}_x$  from diesel engines and gas turbines.

Btu = British thermal units

g = grams

$\mu\text{g}/\text{m}^3$  = micrograms per cubic meter

$\mu\text{m}$  = microns, or micrometers (millions of a meter)

tpd = tons per day

**TABLE 2.4**  
**LIMITS FOR PROCESS WASTEWATER, DOMESTIC SEWAGE AND**  
**CONTAMINATED STORM WATER FOR DISCHARGE TO SURFACE WATERS**  
**WORLD BANK/IFC ENVIRONMENTAL GUIDELINES**

POLLUTANT/PARAMETERS	DISCHARGE LIMIT
pH	6 - 9
BOD <sub>5</sub>	50 mg/l
Chemical Oxygen Demand (COD)	250 mg/l
Heavy Metals, Total (except Barium)	10 mg/l
Metals, specific	
Arsenic	0.1 mg/l
Cadmium	0.1 mg/l
Chromium, total	0.5 mg/l
Copper	0.5 mg/l
Lead	0.1 mg/l
Mercury	0.05 mg/l
Nickel	0.5 mg/l
Selenium	0.1 mg/l
Silver	0.5 mg/l
Zinc	2.0 mg/l
Ammonia	50 mg/l
Cyanide, total	1.0 mg/l
Fluoride	20 mg/l
Chlorine, total residual	1.0 mg/l
Phosphorous	5 mg/l
Sulfide	1.0 mg/l
Phenols	0.5 mg/l
Oil and Grease	10 mg/l
Total Suspended Solids (TSS)	50 mg/l
Coliforms	Less than 400 MPN/100 ml (MPN=Most Probable Number)
Pesticides, Dioxins, Furans and other toxics (such as PAHs)	Less than 100 times the WHO guidelines for drinking water or 0.05 mg/l

**TABLE 2.4**  
**LIMITS FOR PROCESS WASTEWATER, DOMESTIC SEWAGE AND**  
**CONTAMINATED STORM WATER FOR DISCHARGE TO SURFACE WATERS**  
**WORLD BANK/IFC ENVIRONMENTAL GUIDELINES**

Temperature at edge of zone where initial mixing takes place	Maximum of 3°C above ambient temperature of receiving waters
--	--

**Monitoring:** The project sponsor is required to maintain records of air emissions, effluents, and hazardous wastes sent off site as well as significant environmental matters such as spills, fires, and other emergencies that may have an impact on the environment. Information should be reviewed and evaluated to improve the effectiveness of the Environmental Protection Plan. An annual summary of this information is to be provided to IFC in an Environmental Monitoring Report.



**TABLE 2.5**  
**RIGHT-OF-WAY ALIGNMENT**  
**WORLD BANK/IFC ENVIRONMENTAL GUIDELINES**

- All new rights-of-way should be aligned taking environmental factors into consideration, in a manner which will minimize to the extent possible, the need for physical alteration and the impact on sensitive natural environments, cultural resources, agricultural lands, and residential and commercial areas.
- Land acquisition must be carried out in accordance with World Bank resettlement guidelines which require identification and quantification of any impacts on land-based livelihood, and compensation to landowners and people relying on the land for their livelihood.
- Where rights-of-way are to be established through remote and currently inaccessible environmentally sensitive areas, the potential impacts on the natural environment, indigenous populations, population immigration and natural resource exploitation must be assessed and measures adopted to minimize these impacts. Typically, positive measures should be provided to control population influx to remote areas due to increased access created by the pipeline right-of-way, and to prevent associated secondary impacts.
- Environmental impacts of proposed projects should be minimized through such measures as visual impact considerations in siting and design, restricting right-of-way use to non-authorized persons, erosion and sediment control during and after construction, and use of low-impact maintenance procedures.

<b>TABLE 2.6</b> <b>AMBIENT NOISE LEVELS</b> <b>WORLD BANK/IFC ENVIRONMENTAL GUIDELINES</b>		
<b>CATEGORY OF NOISE RECEPTOR</b>	<b>LIMITS IN DECIBELS, DBA</b>	
	<b>DAY TIME</b>	<b>NIGHT TIME</b>
Residential	55	45
Commercial	65	55
Industrial	75	70

Note: The development of roads, airports, and ports and harbors requires that the project sponsors consult with local regulatory authorities concerning mandated noise limits and controls for these types of projects. A noise monitoring program, developed in consultation with the local authorities, must be implemented to characterize noise impacts and determine the potential need for mitigative measures.

**TABLE 2.7**  
**SOLID WASTES**  
**WORLD BANK/IFC ENVIRONMENTAL GUIDELINES**

- a) Project sponsors should recycle or reclaim materials where possible.
- b) If recycling or reclaim is not practical, wastes must be disposed of in an environmentally acceptable manner and in compliance with local laws and regulations.

**TABLE 2.8**  
**HAZARDOUS MATERIALS AND WASTES**  
**WORLD BANK/IFC ENVIRONMENTAL GUIDELINES**

Management measures for handling hazardous wastes and materials should be implemented and can include the following:

- a) All hazardous (reactive, flammable, radioactive, corrosive, and toxic) materials must be stored in clearly labeled containers or vessels
  - b) Storage and handling of hazardous materials must be in accordance with local regulations/international standards and appropriate to their hazard characteristics. Storage and liquid impoundment areas for fuel, raw and in-process materials, solvents, wastes and finished products should be designed with secondary containment (e.g. dikes, berms) to prevent spills and the contamination of soil, groundwater and surface waters.
  - c) Fire prevention systems and secondary containment should be provided for storage facilities, where necessary or required by regulation, to prevent fires or the release of hazardous materials to the environment.
- Asbestos and asbestos containing materials (ACMs) are not to be used in new installations or products. The need to remove asbestos and ACMs from existing applications shall be evaluated on a case by case basis. Disposal of removed asbestos and ACMs should be done in accordance with host country requirements and/or IFC's guidelines.
  - Formulations containing chromates should not be used in water treatment processes.
  - Transformers or equipment containing polychlorinated biphenyls (PCBs) or PCB-contaminated oil should not be installed, and existing equipment involving PCBs or PCB-contaminated oil should be phased out and disposed of in a manner consistent with the requirements of the host country and/or IFC's guidelines.

**TABLE 2.9**  
**HEALTH & SAFETY GUIDELINES**  
**WORLD BANK/IFC ENVIRONMENTAL GUIDELINES**  
**NATURAL GAS PIPELINE TRANSMISSION SYSTEMS**

HEALTH & SAFETY STANDARDS	GUIDELINES										
Workplace Air Quality	<p>a) Periodic monitoring of workplace air quality should be conducted for air contaminants affecting employee tasks and the plant's operations.</p> <p>b) Ventilation, air contaminant control equipment, protective respiratory equipment and air quality monitoring equipment should be well maintained.</p> <p>c) Protective respiratory equipment must be used by employees when the exposure levels for welding fumes, solvents and other materials present in the workplace exceed local or internationally accepted standards, or the following threshold limit values (TLV's):</p> <table style="margin-left: 40px; border: none;"> <tr> <td style="padding-right: 20px;">Carbon Monoxide</td> <td style="text-align: right;">29 mg/m<sup>3</sup></td> </tr> <tr> <td>Hydrogen Sulfide</td> <td style="text-align: right;">14 mg/m<sup>3</sup></td> </tr> <tr> <td>Nitrogen Dioxide</td> <td style="text-align: right;">5 mg/m<sup>3</sup></td> </tr> <tr> <td>Particulate (Inert or Nuisance Dust)</td> <td style="text-align: right;">10 mg/m<sup>3</sup></td> </tr> <tr> <td>Sulfur Dioxide</td> <td style="text-align: right;">5 mg/m<sup>3</sup></td> </tr> </table> <p>d) Monitors should be installed which activate an audible alarm when toxic gas concentrations exceed ½ the above threshold limit values.</p>	Carbon Monoxide	29 mg/m <sup>3</sup>	Hydrogen Sulfide	14 mg/m <sup>3</sup>	Nitrogen Dioxide	5 mg/m <sup>3</sup>	Particulate (Inert or Nuisance Dust)	10 mg/m <sup>3</sup>	Sulfur Dioxide	5 mg/m <sup>3</sup>
Carbon Monoxide	29 mg/m <sup>3</sup>										
Hydrogen Sulfide	14 mg/m <sup>3</sup>										
Nitrogen Dioxide	5 mg/m <sup>3</sup>										
Particulate (Inert or Nuisance Dust)	10 mg/m <sup>3</sup>										
Sulfur Dioxide	5 mg/m <sup>3</sup>										
Workplace Noise	<p>a) Feasible administrative and engineering controls, including sound-insulated equipment and control rooms should be employed to reduce the average noise level in normal work area.</p> <p>b) Plant equipment should be well maintained to minimized noise levels.</p> <p>c) Personnel must use hearing protection when exposed to noise levels above 85 dBA.</p>										
Electrocution	<p>a) Strict procedures must be followed for de-energizing and checking of electrical equipment before maintenance work.</p> <p>b) Strict safety procedures must be implemented, including constant supervision, when performing maintenance work on energized equipment.</p> <p>c) Personnel training must be provided on revival techniques for electrocution.</p>										

**TABLE 2.9**  
**HEALTH & SAFETY GUIDELINES**  
**WORLD BANK/IFC ENVIRONMENTAL GUIDELINES**  
**NATURAL GAS PIPELINE TRANSMISSION SYSTEMS**

HEALTH & SAFETY STANDARDS	GUIDELINES
Work in Confined Spaces	<ul style="list-style-type: none"> <li>a) Prior to entry and occupancy, all confined spaces (e.g. tanks, sumps, vessels, sewers, excavations) must be tested for the presence of toxic, flammable and explosive gases or vapors, and for the lack of oxygen.</li> <li>b) Adequate ventilation must be provided before entry and during occupancy of these spaces.</li> <li>c) Personnel must use air-supplied respirators when working in confined spaces which may become contaminated or deficient in oxygen during the period of occupancy.</li> <li>d) Observers/assistants must be stationed outside confined spaces to provide emergency assistance, if necessary, to personnel working inside these areas.</li> </ul>
Hazardous Material Handling and Storage	<ul style="list-style-type: none"> <li>a) All hazardous (reactive, radioactive, corrosive and toxic) materials must be stored in clearly labeled containers or vessels.</li> <li>b) Storage and handling of hazardous materials must be in accordance with local regulations, and appropriate to their hazard characteristics.</li> <li>c) Fire prevention systems and secondary containment should be provided for storage facilities, where necessary or required by regulation, to prevent fires or the release of hazardous materials to the environment.</li> </ul>
Health - General	<ul style="list-style-type: none"> <li>a) Sanitary facilities should be well equipped with supplies (e.g. protective creams) and employees should be encouraged to wash frequently, particularly those exposed to dust, chemicals or pathogens.</li> <li>b) Ventilation systems should be provided to control work area temperatures and humidity.</li> <li>c) Personnel required to work in areas of high temperatures and/or high humidity should be allowed to take frequent breaks away from these areas.</li> <li>d) Pre-employment and periodic medical examinations should be conducted for all personnel, and specific surveillance programs instituted for personnel potentially exposed to toxic or radioactive substances.</li> </ul>

**TABLE 2.9**  
**HEALTH & SAFETY GUIDELINES**  
**WORLD BANK/IFC ENVIRONMENTAL GUIDELINES**  
**NATURAL GAS PIPELINE TRANSMISSION SYSTEMS**

HEALTH & SAFETY STANDARDS	GUIDELINES
Safety - General	<ul style="list-style-type: none"> <li>a) Shield guards or guard railings should be installed at all belts, pulleys, gears and other moving parts.</li> <li>b) Elevated platforms and walkways, and stairways and ramps should be equipped with handrails, toeboards and non-slip surfaces.</li> <li>c) Electrical equipment should be grounded, well insulated and conform with applicable codes.</li> <li>d) Personnel should use special footwear, masks and clothing for work in areas with high dust levels or contaminated with hazardous materials.</li> <li>e) For work near molten or high temperature materials, employees should be provided with non-slip footwear, gloves, safety glasses, helmets, face protection, leggings and other necessary protective equipment.</li> <li>f) Eye protection should be worn by personnel when in areas where there is a risk of flying chips or sparks, or where intense light is generated.</li> <li>g) Personnel should wear protective clothing and goggles when in areas where corrosive materials are stored or processed.</li> <li>h) Emergency eyewash and showers should be installed in areas containing corrosive materials.</li> <li>i) A safety program should be established for construction and maintenance work.</li> <li>j) A fire prevention and fire safety program should be implemented and include regular drills.</li> </ul>
Training	<ul style="list-style-type: none"> <li>a) Employees should be trained on the hazards, precautions and procedures for the safe storage, handling and use of all potentially harmful materials relevant to each employee's task and work area.</li> <li>b) Training should incorporate information from the Material Safety Data Sheet (MSDS's) for potentially harmful materials.</li> <li>c) Personnel should be trained in environmental, health and safety matters including accident prevention, safe lifting practices, the use of MSDS's, safe chemical handling practices, and proper control and maintenance of equipment and facilities.</li> <li>d) Training also should include emergency response, including the location and proper use of emergency equipment, use of personal protective equipment, procedures for raising the alarm and notifying emergency response teams, including local and regional hospitals, and proper response actions for each foreseeable emergency situation.</li> </ul>

**TABLE 2.9**  
**HEALTH & SAFETY GUIDELINES**  
**WORLD BANK/IFC ENVIRONMENTAL GUIDELINES**  
**NATURAL GAS PIPELINE TRANSMISSION SYSTEMS**

HEALTH & SAFETY STANDARDS	GUIDELINES
Occupational Health and Safety Monitoring	<ul style="list-style-type: none"> <li>a) Records of job related accidents and illnesses (incidents) shall be maintained.</li> <li>b) The records shall include all incidents resulting in an incapacity to work for at least one full workday beyond the day on which the accident or illness occurred. Records must also include the total number of days of absence from work as the result of an incident.</li> </ul>
Records and Reporting	<ul style="list-style-type: none"> <li>a) The project sponsor should maintain records of significant environmental matters, including monitoring data, accidents and occupational illnesses, spills, fires and other emergencies.</li> <li>b) This information should be reviewed and evaluated to improve the effectiveness of the environmental, health and safety program.</li> <li>c) An annual summary of the above information should be provided to IFC.</li> </ul>



**TABLE 2.10**  
**RESETTLEMENT**  
**WORLD BANK ENVIRONMENTAL GUIDELINES**

- Compensation/restitution must be arranged such that all people displaced from land on which they rely for their economic livelihood will continue to have access to means of economic livelihood and lifestyles at least on a par with those available prior to the project.
- Wherever people are displaced from land to which they hold title and on which they rely for their economic livelihood, land restitution is greatly preferred as compensation over a cash payment option. Selection of the cash payment option must be specifically justified.
- Small-scale farmers cultivating land to which they have no title must receive the same compensation for loss of their farming activity and means of livelihood as farmers holding legal title to the lands they are cultivating.
- Any seasonal or migrant laborers who will lose seasonal work opportunities as a result of the project must be identified to the extent practical, their loss of livelihood must be quantified, and they must be compensated appropriately for this loss.
- A resettlement plan must be prepared and submitted to IFC for approval as part of the project review process.

**TABLE 2.11**  
**OTHER GUIDELINES SPECIFIC TO PIPELINES**  
**WORLD BANK/IFC ENVIRONMENTAL GUIDELINES**

- a) Positive pipe corrosion control measures.
- b) Program of periodic inspection and maintenance.
- c) Pressure sensors connected to alarms and automatic shutdown systems.
- d) Metering system should provide continuous input/output comparison for leak detection.
- e) Adequate engineering design providing adequate protection from likely external physical forces.
- f) Accurate and complete records of all inspections, leak incidents, unusual events, and safety measures taken.

**CHAPTER 3.0  
PROJECT DESCRIPTION**

**TABLE OF CONTENTS**

3.1	BACKGROUND .....	3 - 1
3.2	DESCRIPTION .....	3 - 4
	3.2.1 Route .....	3 - 4
	3.2.2 Technical .....	3 - 5
	3.2.3 Logistics .....	3 - 7
3.3	PROJECT OBJECTIVES AND JUSTIFICATION .....	3 - 8
3.4	ANALYSIS OF ALTERNATIVES .....	3 - 9
3.5	PROJECT IMPLEMENTATION .....	3 - 13
	3.5.1 General .....	3 - 13
	3.5.2 Construction .....	3 - 14
	3.5.2.1 Preliminary Work .....	3 - 14
	3.5.2.2 Standard Construction Methods .....	3 - 16
	3.5.2.3 Special Construction Methods .....	3 - 22
	3.5.2.4 Agricultural/Wetlands/Waterbody Area Construction ...	3 - 23
	3.5.2.5 Restoration and Revegetation .....	3 - 29
	3.5.2.6 Spill Prevention and Control .....	3 - 30
	3.5.2.7 Waste Management .....	3 - 32
	3.5.2.8 Environmental Inspection .....	3 - 34
	3.5.3 Operation .....	3 - 35
	3.5.4 Abandonment .....	3 - 38
3.6	HUMAN RESOURCES .....	3 - 38
3.7	SAFETY .....	3 - 39
3.8	BOLIVIA-BRAZIL FIBER OPTIC SYSTEM .....	3 - 41
	3.8.1 Project Background .....	3 - 41
	3.8.2 Project Justification .....	3 - 42
	3.8.3 Description .....	3 - 42

**CHAPTER 3.0  
PROJECT DESCRIPTION**

**LIST OF TABLES**

<b><u>TABLE NO.</u></b>	<b><u>DESCRIPTION</u></b>
3.1	MAIN CHARACTERISTICS OF THE PROJECT
3.2	DESCRIPTION OF THE CAMP SITES IN SPREAD 1
3.3	DESCRIPTION OF THE CAMP SITES IN SPREAD 2
3.4	DESCRIPTION OF STORAGE AREAS
3.5	PIPE STORAGE YARD LOCATIONS AND REQUIRED AREAS
3.6	SUMMARY OF ROADS TO BE UPGRADED IN BOLIVIA FOR GAS PIPELINE PROJECT
3.7	ROAD UPGRADES AND DISTANCES

**CHAPTER 3.0  
PROJECT DESCRIPTION**

**LIST OF FIGURES**

<b><u>FIGURE NO.</u></b>	<b><u>DESCRIPTION</u></b>
3.1	TYPICAL PIPELINE CONSTRUCTION SEQUENCE
3.2	PROPOSED PLOT PLAN FOR 800 MAN CAMP SITE TYPICAL
3.3	PROPOSED PLOT PLAN FOR 120 MAN CAPACITY (OR LESS) CAMP SITE TYPICAL
3.4	LOCATION OF CAMP SITES - SPREAD 1 & 2
3.5	TYPICAL STORAGE YARD LAYOUT
3.6	LOCATION OF STORAGE AREAS IN BOLIVIA - SPREAD 1 & 2
3.7	30 METER WIDE RIGHT-OF-WAY

## 3.0 PROJECT DESCRIPTION

### 3.1 BACKGROUND

Bolivia is a gas-producing country with a significant surplus of natural gas in relation to its internal consumption, while Brazil has a shortage of energy supply. In 1988, the presidents of Bolivia and Brazil signed an Energy Integration Treaty in which Brazil committed to buy electric power generated with natural gas from a thermal plant to be constructed at the border between both countries. The project involved an approximate demand of 100 million cubic feet per day (MM CFD).

The evolution of the Treaty resulted in negotiations for direct natural gas purchase assigned to the main industrial centers in Brazil. On August 17, 1992, the preliminary Contract for the Purchase-Sale of Natural Gas between YPFB and Petrobras (the two state-owned oil/gas companies) was signed in the city of Santa Cruz de la Sierra, Bolivia.

On February 17, 1993 the Final Contract for the Purchase-Sale of Natural Gas between YPFB and Petrobras was signed. The contract, which defines the amount of natural gas to be exported in a 20-yr period, specified that the natural gas volumes to be transported will start at 8.0 MM CMD, growing in seven years to 16.0 MM CMD, and staying at that quantity for the remaining thirteen years of the contract.

On August 17, 1994 YPFB and Petrobras signed a first Addendum to the Contract which established the following:

- The deadline for complying with the condition provided in the twenty-first clause of the Contract (securing financing) was postponed to August 17, 1995.
- Stock ownership in the gas pipeline was specified.
- Agreement was made to increase the diameter of the gas pipeline to a minimum of 32 inches.

Around the time of signing the first Addendum, partners were selected by YPFB and Petrobras to participate in the project, Enron in the Bolivian sector and the BTB Group in the Brazilian sector.

On August 23, 1995, YPFB and Petrobras signed a second Addendum that introduced important changes to the original Contract, especially the following:

1. The term of the contract was extended until August 17, 1996.
2. The establishment of a "Transportation Capacity Option" (TCO) was confirmed, for the first 6.0 MM CMD of additional gas pipeline transportation capacity, above the contractual volume of 16 MM CMD.
3. The initial price of the gas was increased from 0.90 \$US per million BTU to a variable price of 0.95 to 1.06 \$US/per million BTU for the contractual volume of 8 to 16 MM CMD.
4. For additional quantities above the contractual volume, up to the maximum of 30 MM CMD, a base price of \$1.20 \$US/ per million BTU was established.
5. It was agreed that the Gas Pipeline Project is based on the supply of not only industrial markets, but also thermal electric generation markets.
6. It was decided that the diameter of the gas pipeline would be 32 inches, allowing it to transport up to 30 MM CMD, seeking to optimize the transportation cost.

**Project Participants.** The majority equity interest in the project is held by YPFB and Petrobras, together with the participating partners Enron and the BTB Group.

*Yacimientos Petroliferos Fiscales Bolivianos (YPFB).* Yacimientos Petroliferos Fiscales Bolivianos (YPFB), founded in 1936 as Bolivia's national oil company, is involved in the exploration, exploitation, refining and marketing of hydrocarbons. The company has assets of approximately US \$1 billion and produces 30,000 barrels of petroleum products and 530 (MMCF) of natural gas per day. The company operates approximately 6,500 kilometers of pipelines, including twelve oil lines and nine natural gas pipelines.

*Petrobras.* Petrobras, founded in 1953, is Brazil's national oil and gas company, with 81.4% of its voting share capital and 51.0% of its total share capital owned by the federal government of Brazil. Petrobras is engaged principally in the exploration, production, refining, distribution, import, export, trading and transportation of hydrocarbons, hydrocarbon derivatives and products. Petrobras is Brazil's largest company with consolidated assets of over US \$20 billion.

*Enron.* Enron Corporation, one of the world's largest integrated natural gas companies with approximately US \$13 billion in assets, operates the second largest natural gas transmission system in the world; Enron is the largest purchaser and marketer of natural gas and the largest non-regulated marketer of electricity in North America. The company is also involved in the production and marketing of natural gas liquids, exploration and production of oil and gas, and operation of power plants.

*BTB Group.* In December 1993, BHP, Tenneco Gas, and British Gas announced the formation of a consortium (the BTB Group) to participate in the development, financing, and building of the Bolivia-Brazil Gas Pipeline project. Together the BTB group has approximately 50,000 kilometers of gas transmission pipelines in operation around the world and over a quarter million kilometers of local gas distribution lines.

*Tenneco Energy.* Tenneco Energy (formerly Tenneco Gas) is one of the largest natural gas companies in the United States with assets over US \$4 billion. The company operates over 30,000 kilometers of pipelines supplying approximately 1/6 of the total natural gas demand in the United States.

*British Gas.* British Gas is the world's largest natural gas company with assets of US \$40 billion. Its holdings operate gas distribution networks totaling over 240,000 kilometers in length serving over 18 million consumers in 40 countries.

*BHP.* Broken Hill Proprietary Company Limited (BHP) is Australia's largest company, and in 1994 ranked 126th on the "Fortune" Global 500 list of the world's largest industrial companies. BHP is an international producer of minerals, steel and petroleum products. The company has total assets of about US \$20 billion, and has operations in more than twenty countries.



## 3.2 DESCRIPTION

### 3.2.1 Route

The Bolivia-Brazil Gas Pipeline will extend approximately 3,100 kilometers from YPFB's Río Grande Natural Gas Plant located approximately 40 kilometers southeast of the city of Santa Cruz de la Sierra, Bolivia, through the State of São Paulo, turning South and terminating near the city of Porto Alegre in Brazil. The approximately 557 kilometer Bolivian sector of the transmission system will follow a relatively straight line, running in a west to east direction (Figure 1.1). The pipeline will cross the predominantly flat tropical dry forest of the Bolivian Chaco region within the Department of Santa Cruz, in the southeastern portion of Bolivia. The right-of-way will run parallel to and south of an existing railway from a point approximately 40 kilometers west of the town of El Carmen, then in a southeast direction to the town of El Carmen de la Frontera, south of the town of Puerto Suárez on the Bolivia-Brazil border. East of the Otuquis river, the gas pipeline will cross the northern portion of the Otuquis and Tacuaral marshes.

A portion of the pipeline route marks the northern boundary of the Gran Chaco National Park, which was established by law in 1995 to protect the unique ecosystem of the Chaco. The proposed pipeline route lies between the Integrated Management Area and the protected reserve of the park. Although almost two-thirds of the Bolivian pipeline sector crosses uninhabited areas, there are a few population centers to the north in the vicinity of the pipeline. These include Pailón, San José de Chiquitos, Roboré, El Carmen, and Puerto Suárez.

The pipeline route crosses three principal rivers in Bolivia. Each of the rivers are east of the Río Grande Gas Plant with the approximate distance from the plant provided below:

- Río Grande                      10 km
- Río San Miguel                295 km
- Río Otuquis                    427 km

The Brazilian sector of the pipeline begins at the Bolivia-Brazil border, south of the city of Corumbá in the state of Mato Grosso do Sul, and continues southeast crossing the Paraguay river.

The route continues through the Pantanal marshland running somewhat parallel to Highway BR-262. In the 700 kilometer segment through Mato Grosso do Sul, the pipeline crosses the Miranda, Pardo and Verde rivers. The pipeline then crosses the Paraná river into the state of São Paulo, continuing southeast and crossing the Tiete river. At Capao Bonito, it crosses the Paranapiacaba mountain range, then reaches the Itapirapua river which separates the states of São Paulo and Paraná. The route crosses the Ribeira river and follows the existing right-of-way for existing oil pipelines, into the state of Santa Catarina then across the Tijucas Mountain Range and the Tijucas river. From this point, the route follows a new right-of-way, passing west of Florianópolis and terminating near the Alberto Pasqualini Refinery outside Porto Alegre.

### 3.2.2 Technical

The pipe required for the Bolivian sector will be 32 inch in diameter, 0.406-0.649 wall thickness, manufactured in accordance with API-5L, X-70 standards. External coating will include one of several alternatives of anti-corrosive coatings supplemented by a system of cathodic protection. This cathodic protection system will consist of buried sacrificial anodes and rectifiers. The pipeline will be designed for a maximum allowable operating pressure of 1,420 psi. The primary design criteria of the project are summarized in Table 3.1.

Automatic reduced pressure shutdown valves will be installed to ensure safety of the line. Locations of these valves will be determined during the detail design phase of the project.

Pig launchers and receivers will be installed for the purpose of internal inspection and cleaning of the pipe. The inspection runs may be carried out while the system is in service, using the intrinsic flow of the gas to move them along. Cleaning and intelligent pigging operations will be done as determined necessary during the operation of the pipeline.

Four compressor stations will be included in the system design for the Bolivian sector. One station will be installed near the town of Yacuses in the first phase of the project, and the remaining three will be constructed as required to increase delivery volumes and maintain acceptable pipeline pressure. Conceptual design indicates that there will be four turbine compressors at each station at full design flows. Detail design will be performed before the final

selection of equipment. The preliminary hydraulics analysis was based on Taurus 60 compressor units as manufactured by Solar. The Taurus 60 turbine is rated at 6,960 hp ISO. Each of the compressor station sites will have a perimeter fence enclosing an area of approximately 300 meters by 300 meters.

There will be two metering stations in Bolivia. The first station will be located at the Río Grande Gas Plant to measure the volumes of gas entering the pipeline owned by the Bolivian Transportation Company, and the second station at the Bolivia-Brazil border to measure the gas for custody transfer to the Brazilian Transportation Company.

The gas pipeline will be provided with a Supervisory Control and Data Acquisition (SCADA) System for the centralized monitoring and operation of the system. The line pressure and operating status of the compressors located in Bolivia will be controlled from a central office in Santa Cruz.

The installation of a fiber optic cable will be included within the scope of the Project. The cable may either be placed in the same ditch as the pipeline or in a separate ditch within the pipeline right-of-way. If direct burial cable or conduit are to be installed within the same ditch as the pipeline, it will be installed during pipeline lowering-in and prior to ditch backfill. Additional narrow ditches outside the pipeline ditch would be required for pull boxes (splices, junctions). These junction boxes would be located within the permanent right-of-way. At wetlands and river crossings, conduit will be strapped to the concrete coated pipe prior/during installation and the cable pulled through during tie-ins or at a later date. At bored road crossings, a separate bore for conduit will have to be made. If direct buried cable or conduit are to be plowed-in or installed outside (3.7 - meters) of the pipeline ditch, it will be installed after backfill and prior to final clean-up of the right-of-way. All work involving excavation and soil movement would occur within the original right-of-way of the pipeline construction.

### 3.2.3 Logistics

The logistics plan has been developed based upon current knowledge; however, when contractors and equipment suppliers are identified and purchase orders are released, details of the plan will be finalized. The pipe will likely be imported to Bolivia through the Port of Rosario in Argentina, which will be the receiving port for ocean freight. From the Port of Rosario, pipe will be transported to the Port of Aguirre on the Bolivia-Brazil border, then by train to designated storage yards in Bolivia. From the storage yards, pipe will be transported by truck to the right-of-way for stringing. Other possibilities include, 1) receiving the pipe through the port in Arica, Chile, transporting by truck to Santa Cruz, then to the storage yards by railway, or 2) receiving the pipe through the port in Buenos Aires, Argentina, transporting via the Belgrano Railway to Santa Cruz, then to storage sites by rail.

The Port of Aguirre facilities in the Puerto Suárez/Corumba area will be utilized for off-loading pipe from barges arriving from the Port of Rosario. Port of Aguirre is a private port located on the Tamengo Canal which traverses between the Paraguay river and Laguna Caceres (Caceres Lagoon) at Puerto Quijarro, Bolivia. The port is also a "Zona Franca", a duty free zone. This site has ample space for storage and sufficient area to accommodate double jointing of pipe and a corrosion coating plant, if required. A portable coating facility will be installed at Port of Aguirre if field applied Fusion Bond Epoxy (FBE) is the external coating of choice. The external coating protection of choice and the application method will be selected in the detail design phase of the project. It is possible that pipe would be imported with coating applied at the pipe mill, therefore a coating plant would not be required. Another option is to "line travel" coat the pipe, where a coating plant would not be required at Port of Aguirre. The site also has ample railroad spurs for moving pipe inland from this site to pipe storage sites along the railway.

The rail locations which will be utilized for off loading pipe include:

- Santa Cruz
- El Carmen
- Puerto Suárez Arana
- Roboré
- Pailón
- San José de Chiquitos

The Santa Cruz site has sufficient existing spur lines, therefore no new construction is needed. However, Pailón will use a grain storage site which will require a track extension. San José de Chiquitos will utilize the area of the YPFB petroleum distribution yard, and one 300-meter long additional rail spur will be required. The additional rail spurs of ENFE (Railroad National Company) on the station property can also be used for storage of rail cars. If additional area is required, the property to the east will be utilized for storage space. Roboré has sufficient existing railroad tracks. There is one additional spur other than the passing track as well as the two tracks for cattle loading. One additional 300 meter spur will be constructed at El Carmen. Puerto Suárez Arana has sufficient existing rail spurs to be used for off loading and loading pipe, therefore no new rail spur construction will be required.

Another rail yard which is a possible location for off loading of pipe is Tres Cruces. The use of Tres Cruces would require the construction of one 300 meter rail spur and the burial of overhead wires for approximately 350 meters.

### **3.3 PROJECT OBJECTIVES AND JUSTIFICATION**

The general objective of the project is to build and operate a gas pipeline for transport and delivery of natural gas from production fields in Bolivia, to markets in Brazil. The Bolivia-Brazil Gas Pipeline will benefit both countries by providing Bolivia with a gas market and Brazil with an additional energy source. In order to meet the requirements of the Contract for the Purchase-Sale of Natural Gas between YPFB of Bolivia and Petrobras of Brazil, the project involves the installation and operation of a pipeline that will extend from the Río Grande Gas Plant in Bolivia to Porto Alegre in Brazil.

The project is justified primarily due to the following reasons:

- Bolivia is a gas-producing country, while Brazil faces energy limitations.
- Market analysis suggests that the initial demand for natural gas from Brazil will be approximately 8.0 MM CMD. The assessment of existing gas reserves in Bolivia indicates that there are sufficient reserves to make the project feasible.

- The preliminary financial analysis suggests that the design capacity of the gas pipeline can sustain a competitive tariff schedule for the transported gas.
- The route selection allows for an environmentally acceptable alternative.
- Gas is the cleanest energy source available. The use of natural gas will reduce air pollution in Brazil, which will be a major benefit especially in industrialized areas, such as São Paulo.

### 3.4 ANALYSIS OF ALTERNATIVES

The proposed route for the Bolivian portion of the Bolivia-Brazil Gas Pipeline was selected based on the study performed by CUMAT (CUMAT 1990). This section discusses and compares the route alternatives for the project based on both the previous study and an assessment of current conditions within the study area.

The following general criteria were considered in assessing routing alternatives for the project:

- Design the overall project size, and general facility configuration to maximize production efficiency within defined project constraints, both economic and environmental.
- Maximize the use of existing disturbed areas (such as existing road corridors).
- Minimize disturbance to indigenous areas during facility infrastructure and pipeline construction and operation.
- Minimize effects to sensitive habitats, cultural resources, and related culturally sensitive areas.
- Avoid existing communities and related structures.

- Minimize possible effects from geologic hazards and constraints such as fault crossings, significant erosional features, and landslide-prone areas.

Based on these general criteria, the following were among the alternatives identified and considered:

*No-Project.* The alternative of not executing the project was included.

*Alternative No.1.* The pipeline would run parallel to the existing railroad between Pailón and Puerto Suárez, which is shown in Figure 1.1. Under this alternative, the Bolivian portion of the pipeline would run adjacent to or through several populated centers such as Pailón, San José de Chiquitos, Roboré, El Carmen, and Puerto Suárez. This route would generally run along the southern foothills of the Serranías Chiquitanas.

*Alternative No.2 (Proposed).* The proposed alternative follows a relatively straight route from the Río Grande Gas Plant to Puerto Suárez, across the Bolivian Chaco region. Portions of this route mark the northern border of the Gran Chaco National Park. This alignment converges with the existing railroad corridor near El Carmen and, from El Carmen, it runs in a straight line to El Carmen de la Frontera at the border with Brazil. Other components of the project, such as the number of camps, compressor stations, and meter stations would be similar in alternatives 1 and 2.

Operational criteria and considerations used to establish the two corridors included:

- Corridors should be as short as practicable to minimize material, right-of-way, and construction costs and restoration and impacts to the environment.
- Corridors should avoid traversing mountainous areas because of the additional difficulties in pipeline construction and potentially unstable soils.

- Existing access within corridors, by road or other means, should be available for transporting construction materials and equipment and conducting pipeline inspection, maintenance, and repair.

The two corridors were evaluated by:

- Considering the environmental and socioeconomic environments of each corridor.
- Comparing estimated capital and operating costs.

In the CUMAT study, the environmental evaluation of the two corridors was based on terrain unit mapping and establishing a "friction coefficient" which measured the constraints to executing the project within each corridor. Their results are summarized as follows:

- Alternative No. 2 was preferred from an environmental perspective, mainly because it traverses relatively homogeneous terrain and avoids areas of slope instability along the southern foothills of the Sierras Chiquitanas.
- Alternative No. 1 would run close to populated areas and along the few areas under active agricultural uses within the study area. Alternative No. 2 would run across more undisturbed forests and the Bañados de Izozog. Both alternatives would traverse the Bañados de Otuquis.
- Project costs were estimated to be lowest for Alternative 2 attributable to the less difficult construction conditions and the shorter distance of construction.

Once Alternative No. 2 was selected as the most suitable, additional analyses were conducted to identify the preferred pipeline alignment and compressor station locations within the corridor. In 1993, a 5-10 m wide cut line was established to survey the majority of the selected route. The cut line is still clearly visible through most of the alignment. The proposed alignment would utilize the existing disturbed corridor.



During this study, two environmental concerns were identified which resulted in refinements to the project:

1. The logistics assessment had identified the locality of Naranjos as a storage area with an access road to the pipeline right-of-way. The area reconnaissance revealed the existence of a nearly pristine mesic forest between Naranjos and the right-of-way. Evidence of incipient human encroachment into this area was observed along a narrow access road built three years ago. It was decided that this location and access road would not be used to prevent additional direct impacts to the forest and to discourage further encroachment along the access road.
2. As originally proposed, the route was designed to traverse the Cañón de la Victoria across its narrowest point, thus minimizing the length of the direct impact to the wetland. The Cañón de la Victoria is a hydrologic and biological connection between the wetland systems of the Bañados de Otuquis, in Bolivia, and the Pantanal, in Brazil. The review of the area suggested that the pipeline crossing at the narrowest point would affect a nearly pristine marsh and may affect the hydrologic connection between the systems. A route modification was proposed to make the route parallel to the existing road/railroad corridor, where the pipeline would traverse a longer section of the floodplain, but along and already disturbed corridor. Thus, the new route will result in minimal additional impacts to this regional wetland system.

Under the no project alternative, existing environmental conditions throughout the study area would remain as they are at present or continue to suffer degradation or deterioration due to human encroachment or natural resource exploitation. Similarly, if the project is not implemented, potential adverse impacts on the human, biological, and physical environments as a result of proposed project would not occur. However, the no project alternative would not address the energy shortage in Brazil. In the absence of clean burning natural gas, alternative fuel sources could result in greater adverse impacts on the environment. Likewise, the potential beneficial impacts realized as a result of project implementation (e.g., increase in local jobs, increased revenues to the Bolivian government, new and improved infrastructure) would not be realized.

As the project is anticipated to be of net benefit to Bolivia, the no project alternative would result in a lost opportunity for the people of Bolivia.

The proposed route for the Bolivian portion of the Bolivia-Brazil Gas Pipeline was chosen to best satisfy the general development criteria described at the beginning of this section. The proposed project also was determined to best balance overall impacts to the human, biological, and physical environment while achieving its overall purpose, which is to transport natural gas from the fields in the Santa Cruz area to the market in southern Brazil through an environmentally acceptable and economically viable program.

### **3.5 PROJECT IMPLEMENTATION**

#### **3.5.1 General**

The implementation phase of the project is not expected to occur until 1997. Mobilization of construction contractor personnel is scheduled for June, 1997 and demobilization is planned for July 1999. Detail design and right-of-way acquisition will be the first activities to be initiated. The proposed right-of-way will be thirty (30) meters in width, including both the temporary work space and the seventeen (17) meter permanent right-of-way (see Figure 3.7). Construction activities will be planned to minimize conflicts between construction and other uses of the land. Landowners, tenants, or administrators of public lands will be informed of the schedule for construction across their property. Most of the pipeline infrastructure to be constructed will be below ground. The pipeline will be installed approximately one meter below grade. Installation of fiber optic cable will be within the pipeline trench or in a separate ditch within the same right-of-way. Compressor stations, metering stations and line valve operators will be installed above ground. Storage yards, construction camps, and temporary work spaces will be restored and allowed to revegetate and return to a natural state. Access roads and permanent right-of-way will be maintained to service the facilities to be constructed.

The project includes the following permanent infrastructure components:

- Pipeline
- Compressor stations
- Metering stations
- Access roads
- Permanent right-of-way

There will also be temporary components such as storage yards, personnel camps, and temporary work spaces.

### **3.5.2 Construction**

To assist the organization of the construction phase of the project, the project area in Bolivia has been divided into two spreads. Spread No. 1 is the western half of the pipeline in Bolivia from the Río Grande Gas Plant to approximately kilometer post (KP) 305, and Spread No. 2 is the eastern half of the pipeline in Bolivia from this point to the Brazilian border. The typical sequence of activities involved in the construction phase of the project is depicted in Figure 3.1.

#### **3.5.2.1 Preliminary Work**

The first crews mobilized will execute the preliminary work needed to support the project through the construction phase. The preliminary work will consist of, but not necessarily be limited to, preparation of access roads, construction of personnel camps, storage yards and appropriate waste disposal facilities, mobilization of pipe and general supplies to the storage yards and mobilization of personnel and equipment.

Personnel will be mobilized to the site primarily by ground transportation such as buses, trucks, and railway. To reach some of the outlying areas, the construction contractor will utilize air transportation, either his own or charter service. Currently, the air strips at Roboré and San José are suitable for Twin Otters, Dash-8, Dornier, or the equivalent. As the contractor commences preliminary work, air strips at El Carmen and Isla Verde will be upgraded as necessary.

Various transportation systems such as ports, roads and railroads in Bolivia will be selected to meet the requirements of the project. This will enable materials to be transported in an effective and efficient manner to storage yards and end use areas.

**Access Roads.** Several access roads will be upgraded and utilized to service this project. There are a total of eleven existing roads which will require some degree of work. A summary of the less traveled roads, which the project will upgrade, and a synopsis of the proposed rework is included in Table 3.6. Improvements will also be required for a portion of the main road from Pailón to Puerto Suárez. It should be noted that this segment between Pailón and El Carmen is not included in Table 3.7, as this section of the road is periodically maintained by the Province of Santa Cruz. Alterations completed by the project will be performed as required, based on field conditions found at the time of construction.

No new access roads are proposed. The majority of the required rework consists of drainage improvements and reshaping of existing roadways. Access roads may require side ditches and water bars or terraces to provide drainage. If side ditches are required, they shall be excavated parallel to the road in such a way to channel runoff away from the road. For the most part, the access roads are constructed of naturally occurring soil materials. In some areas where native soils are not stable, more stable materials will be used on the roadway to support heavy construction equipment. In the populated areas, some of the roads have imported gravel or paved surfaces. Upon completion of construction, the roads will be returned to their original or better condition.

**Camp Sites.** The number and location of camp sites to support the construction work were determined using the following criteria:

- Minimize disturbance of virgin ground
- Maximize use of readily available access roads
- Minimize number of camps and the size of the areas, primarily by:
  1. Using areas for multiple purposes (e.g., camp and storage)
  2. Sharing sites (e.g., use one camp location for the two construction spreads)
- Minimize distance to railroad storage yards.

A typical main camp will require an area of 3.2 hectares and will have a 800-person capacity (Figure 3.2). The small camp at the Rio Grande Gas Plant will require an area of 1.0 hectares with a 120-person capacity (Figure 3.3). A total of eight camps will be constructed in Bolivia, five of which will be located in the western half of the route, and the other three will be located in the eastern half. The total area that will be utilized for all camp sites is 23.4 hectares. Four main camps and one small camp will be constructed in Spread 1 and four main camps will be constructed in Spread 2 (Figure 3.4). Descriptions of the camp sites in Spread 1 and 2 are summarized in Tables 3.2 and 3.3 respectively.

**Storage Yards.** At each location designated for pipe receiving, the storage yard site has been selected with railroad service and required access road. A typical layout of a storage yard is shown in Figure 3.5 and the proposed locations of storage areas in Bolivia are shown in Figure 3.6. A description of the storage yards for the Bolivia portion of the pipeline and any alterations proposed for the area are included in Table 3.4. These yards are located at railroad stations where line pipe and other materials will be stored during the construction of the pipeline. The areas required to store pipe and construction materials at each location are listed in Table 3.5.

### 3.5.2.2 Standard Construction Methods

Construction of a natural gas pipeline consists of the following distinct phases: clearing, grading, ditching, lowering-in, backfilling, hydrostatic testing and restoration. The construction methods described herein will be used unless site-specific conditions warrant special methods. Figure 3.1 shows a typical right-of-way configuration, depicting the sequence of construction activities that will take place.

Preconstruction surveys will be conducted by the company to determine the specific needs of the project. Information on soils was obtained from CORDECRUZ (the planning organization of the Department), including land use capacity and soil cartography.

**Clearing.** Clearing involves the removal of trees, brush and other vegetation from the right-of-way. As clearing will disturb soils, making them more susceptible to erosion, specific

environmental procedures will be followed in order to mitigate any negative environmental impacts. The following standard procedures will be followed during clearing:

- Right-of-way boundaries (e.g., limits of work) will be clearly delineated and the Inspector will ensure that no clearing occurs beyond these boundaries.
- Stemmed vegetation such as brush, shrubs and trees shall be removed at or near the ground level, leaving the root systems intact to the greatest extent practical.
- All fences, whether they be for livestock or security, shall be maintained by the use of a temporary fence section (gap).
- Any trees which have fallen into waterbodies or beyond the edge of the right-of-way shall be removed immediately.
- Trees located outside of the right-of-way will not be cut.
- Timber not specifically designated for other uses will be left in tree lengths and neatly stacked along the edge of the right-of-way used for rip-rap or to control erosion. Rip-rap shall be removed from the right-of-way after construction is complete.
- Tree stumps shall normally be removed along the entire width of the right-of-way to allow adequate clearance for the safe operation of vehicles and equipment.
- Cleared materials may not be buried in wetlands, agricultural lands or residential areas. Stumps removed on the right-of-way will be buried.
- Burning of brush is permitted unless specifically prohibited in an area. Appropriate precautions must be exercised to prevent wild fires in the surrounding area.

**Extra Work Space.** The proposed width of the construction right-of-way is 30 meters. At major river crossings, extra work space will be required for storage of additional excavated soil material,

pipe assembly, and storage of materials and equipment. Along the alignment, the following four locations will require extra work space:

- Río Grande: west side - 60 meters x 60 meters; east side - 30 meters x 60 meters
- Río Otuquis: west side - 60 meters x 60 meters; east side - 30 meters x 30 meters
- San Miguel: west side - 30 meters x 60 meters; east side - 60 meters x 60 meters
- Río Parapetí: west side - 30 meters x 30 meters; east side - 30 meters x 30 meters

**Grading.** When existing topography does not permit equipment to operate safely and does not provide access or an efficient work area, grading will be required. Sharp topographic irregularities will be graded to ensure rapid and safe passage of work crews and equipment. Rock outcrops, ridges, boulders and tree stumps shall be removed from the work area. Grading shall be performed by dozers equipped with ripper and grading blades. The following general construction methods will be employed during grading:

- Wetlands will not be filled with soils from adjacent uplands.
- Water bars/terraces will be installed diagonally across the right-of-way on slopes to control erosion as specified in the Environmental Management Plan (Appendix B).
- A sufficient stockpile of silt fence shall be maintained on site for emergency use.

**Pipe Stringing.** Once the right-of-way has been cleared and graded, the pipe will be transported from storage areas and laid out along the right-of-way. The pipe will be placed in such a way that the movement of vehicles and other equipment needed for construction is not restricted. Initially, pipe will not be placed directly on the ground, but rather it will be placed on wooden supports along the length of the right-of-way.

**Pipe Bending.** Pipe will be bent in areas where the terrain is sinuous on the right-of-way curves, thereby requiring the pipe to follow a curve. A bending machine will be utilized when needed; however, it will be necessary to ensure that deformities in the pipe are not present when this procedure is undertaken.

**Welding (Joining Operations).** Prior to alignment and joining operations, the pipe will be inspected, repaired (if required) and cleaned particularly at the ends of the pipe. Alignment procedures involve placing the pipe in line with opposite ends facing each other. Internal and/or external clamps will be utilized to hold the pipes together and properly align and fix them in place during joining operations. Automatic and semi-automatic welding systems and stick welding will be utilized.

**Welding Inspection.** The exterior of the pipe will be visually inspected initially to check the quality of the welding. Subsequently, radiography or other acceptable testing methods will be employed to check the quality of the welding in the interior of the pipe. Depending on the findings of the different quality control tests, appropriate measures will be taken. In the event that a defect is detected, the pipe will be repaired.

**Ditching.** Once the pipe sections have been welded together and the corrosive coating has been applied to the joint and inspected, trenching will proceed in the right-of-way. Ditching can also be done prior to welding. The bottom of the trench will be leveled uniformly at the required depth, and construction guidelines will be followed in order to prevent environmental damage from occurring. The length of time the ditch is left open shall be minimized as much as practicable.

Topsoil excavated from the Aeolic Plain, wetlands, and cultivated agricultural lands is required to be segregated from subsoil. Topsoil will be segregated as part of the ditching procedure.

- Topsoil stripping shall be accomplished as follows:

*Cultivated Agricultural Areas* - Topsoil should be stripped over ditch line.

*Wetland Areas* - Topsoil must be stripped over ditch line only.

*Forest and other areas* - Topsoil stripping is not required.

*Aeolic Plain Area* - Topsoil will be stripped over the ditch line



**Lowering-in/Backfilling.** After the trench is excavated and welding procedures are completed, the pipe will be lowered in gradually and uniformly so that the weight of the pipe is evenly distributed. Once lowered in, the pipe should lay directly on the ground. As soon as practicable after the pipe is lowered in, the trench will be backfilled with the same soil material that was excavated. This material will then be compacted or a crown installed in order to prevent future erosion problems.

During lowering-in and backfilling, the following standard techniques will be used:

- Under no circumstances will trench water or other forms of turbid water be directly discharged onto exposed soil or into any wetland or water body.
- The discharge shall be equipped with a device to dissipate the velocity to prevent erosion and scouring.
- Under no circumstances will topsoil be used as padding.
- Subsoil will be placed in the trench first. Where topsoil has been segregated, it will be graded uniformly over the width of the excavated area.
- Excavated and blast rock may be used as backfill above the layer of padding in agricultural, wetland, and residential areas, up to the level of bedrock.
- Heavy equipment may be used to compact the backfilled ditch to minimize settling, or else a crown of soil will be put over the pipeline to compensate for any future soil settling which may occur. Openings shall be left in the trenchline crown to allow for lateral surface drainage.

**Hydrostatic Testing.** Hydrostatic testing will validate the integrity of all pipeline segments. In order to test the integrity, pipeline segments will be capped with test manifolds and the capped segments filled with water. The water will be pressurized and held for 8 hours (4 hours for pretested fabricated units and short, visible sections). Any significant loss of pressure would

indicate that a leak may have occurred. The source of the water used for testing will be from local streams and rivers. Hydrostatic testing of the pipe will be performed in one or more pipe segments.

The potential for environmental impacts from withdrawal and discharge of test water shall be minimized by utilizing the following procedures:

- Hydrotest the pipeline sections before installation under waterbodies.
- Fill and spill activities will be in compliance with all license or permit requirements.
- Adequate flow rates will be maintained to protect aquatic life, provide for all water body uses, and provide for downstream withdrawals of water by existing users.
- Test water shall be discharged either to a suitable receiving body of water, across a well-vegetated area or filtered through a filter bag or erosion control barriers.
- The rate of discharge shall be controlled to prevent flooding or erosion.

**Cathodic Protection of Pipeline.** To protect the pipe from corrosion, a cathodic protection system will be installed. This system will consist of the installation of anodic beds at various points along the pipeline. Due to an electrochemical process, oxidation in the pipe is prevented as the material in the anodic beds are oxidized rather than the pipe material itself.

The system will be tested prior to the commencement of operations and the difference in potential along the length of the pipe will be measured and routinely monitored.

**Final Clean-Up.** Once construction of the pipeline is completed, any materials or equipment not needed for the operation of the pipeline will be removed from the right-of-way. Materials such as wooden supports for the pipe, waste from welding operations, wrappers, packages etc. shall all be removed and properly stored or disposed.

### 3.5.2.3 Special Construction Methods

Specialized construction techniques will be used as required in certain areas along the pipeline route. These techniques include:

**Blasting.** Installing the pipe may require blasting in some areas, such as those with rock. All blasting will be performed by qualified blasters and monitored by blasting inspectors.

**Drag Sections.** Drag sections are used when work space is limited or when trying to reduce the time necessary to work in a given location. Drag sections are multiple joint sections of pipe which have been pre-assembled (bent, welded, x-rayed, coated, etc.) in a staging area near, but not adjacent to, the ditch where it will eventually be placed. Drag sections are carried into place pre-assembled.

Drag sections are used for road, water body and wetland crossings, residential areas and other locations. This technique will be used when there is insufficient room to assemble the pipe in place or where the obstruction of having the pipe sitting along the ditch for a long period of time, (such as a road crossing), is unacceptable. Generally, each section is several joints long, but not so long that it cannot be picked up and carried (it is not dragged) as one piece by the available equipment.

**Boring.** Boring entails drilling a hole below travel arteries, such as highways and railroads through which the pipe will pass. This method will be used in sensitive areas where the artery cannot be crossed by conventional open cut methods.

**Jacking.** Jacking is similar to boring except that an open-ended casing is forced, or jacked through the earth below the artery. Soils are then removed from the casing. The remainder of the installation procedure is identical to that described for boring.

**Directional Drilling.** Directional drilling requires the drilling of a small diameter hole, or pilot hole, along a predetermined design path. The pilot hole is then enlarged sufficiently to accommodate the pipeline to be installed. The pipeline may or may not be installed concurrently

with the hole enlargement, depending upon the final diameter of the enlarged hole and the soil conditions encountered.

This method requires a large area of temporary work space at the entry and exit points. Directional drilling is used only in areas where boring and conventional open cut methods are not suitable.

**Equipment Crossovers.** In an equipment crossover, the working side of the right-of-way temporarily shifts to the other side of the right-of-way. Equipment crossovers will be used to reduce impacts to sensitive areas such as residential, wetlands, and archaeological sites.

The use of equipment crossovers will be reserved for extreme circumstances because of the requirements for the construction equipment to work backwards.

#### **3.5.2.4 Agricultural/Wetlands/Waterbody Area Construction**

##### **Grading.**

- Prior to grading, the Environmental Inspector shall determine the depth of topsoil to be stripped and segregated and enter the information into a field book for future reference. The depth to which the topsoil will be stripped will be to its actual depth or to a maximum depth of 30 centimeters.
- Natural flow patterns of cultivated fields will be maintained by providing breaks in topsoil and subsoil stockpiles.
- In all actively cultivated agricultural lands, which includes permanent or rotated cropland, hayfields, or improved pastures, topsoil stripping over the ditch line shall be used. Additional temporary work space will be used for topsoil storage in agricultural areas.

### **Ditching/Lowering-In/Filling.**

- Where necessary, maintain natural flow in the identified drainage systems during construction.
- All drainage systems shall be inspected to determine if damage has occurred. Any damage incurred during construction shall be flagged by the trench inspector, then repaired to its original or better condition.
- Detailed records of drainage system repairs shall be kept and given to the landowner for future reference upon request.

**Wetland Crossings.** Potential adverse impacts to wetlands will be minimized by:

- expediting construction in and around wetlands, and limiting the amount of equipment and mainline construction activities within wetlands to reduce disturbances of their wetland soils and drainage systems;
- restoring wetlands to their original configurations and contours;
- stabilizing upland areas near wetlands, as required, to prevent erosion using control measures and vegetative cover as soon as possible after backfilling.

The size of staging areas at wetland crossings will be limited to the space necessary for fabricating only those pipe segments required for the crossing. Other additional work spaces at wetland crossings, such as additional spoil storage areas, will also be limited to the size necessary to perform their function. All additional work space areas will be located at least 10 meters from the edge of the wetland where topographic conditions permit. The wetlands and setbacks will be clearly marked prior to the start of construction.

Hazardous materials, chemicals, fuels or lubricating oils will not be stored nor will concrete coating activities (excluding field joints) be performed within 15 meters in any direction of any

water body. In addition, construction equipment will typically not be refueled or serviced within 15 meters in any direction of any wetlands or water body.

Spoil placed up-gradient of wetlands will be contained with sediment control devices as necessary to prevent spoil materials from flowing into wetlands or off of the right-of-way.

Unless a site-specific method is recommended, one of the following four methods will be used for crossing wetlands during construction.

- Method I: Standard Pipeline Construction Method
- Method II: Conventional Wetland Construction Method
- Method III: Push/Pull Wetland Construction Method
- Method IV: Other (Site-Specific concerns to be determine during final design)

The proposed method of crossing each wetland will be determined in the field, based on the site specific conditions found at the time of construction.

**Method I: Standard Pipeline Construction.** This method (Wetland Method I), can be used in wetlands where soils are dry enough at the time of construction to support mainline construction equipment. Thus, this method is typically used during the dry season, when rainfall is at a minimum, and the water table is lowest. This crossing method requires the segregation of topsoil from subsoil. Specific characteristics regarding this construction method are presented in Appendix B.

**Method II: Conventional Wetland Construction.** This method (Wetland Method II), will be used for crossing wetlands with saturated soils or soils otherwise unable to support mainline construction equipment. Because the soils are saturated, there is a need to stabilize the right-of-way to support equipment during construction. The right-of-way will be stabilized by using timber rip-rap, fabricated timber mats or gravel over geotextile fabric. All stabilization materials will be removed after construction is complete. Specific characteristics regarding this construction method are presented in Appendix B.

**Method III: Push/Pull Wetland Construction.** This method (Wetland Method III), entails pushing or pulling a floating section of pre-assembled pipe into position over an inundated trench. The floats are removed and the concrete-coated pipe sinks into the trench. The section of pipeline to be floated into place must be straight or nearly straight to be able to float within the confines of the excavated ditch. This method should be used in large wetland areas where water levels are high enough at the time of construction to float the pipeline into the trench and where such levels can be maintained without damming. Specific characteristics regarding this construction method are presented in Appendix B.

Additional work space may be needed adjacent to the wetland boundaries for pipe fabrication.

**Water Body Crossings.** The Project shall protect and minimize potential adverse impacts and disturbances to waterbodies by:

- expediting construction and limiting the amount of equipment within waterbodies;
- reducing clearing, leaving in place as many trees as possible on stream banks;
- maintaining downstream flow rates;
- removing all materials and structures related to construction from each water body bed after construction;
- restoring stream channels and bottoms to their original configurations and contours;

Construction staging areas for water body crossings will be as small as possible, while still allowing for prefabrication of pipe segments that will cross the water body. Other additional work spaces, such as spoil storage areas, at water body crossings will also be limited to the size necessary to perform the required function. All additional work space areas will be located approximately 10 meters in any direction from the stream banks, where topographic conditions permit.

Trench spoil will be stored at least 10 meters back from stream banks at water body crossings, where possible. Spoil placed up-gradient of stream banks will be contained with sediment control devices to prevent spoil materials from flowing into waterbodies or off the right-of-way.

Construction of equipment crossings will occur during the clearing or grading process. Protective measures will include the use of timber mats laid adjacent to and across streambeds if banks are high enough, flume pipes covered by fill material or portable bridges.

The following crossing procedures will be applied to waterbodies:

**Method I: Wet Crossings.** This method will be used for crossing intermittent streams and non-sensitive, perennial streams. Specific characteristics regarding this procedure are presented in Appendix A.

#### Clearing/Grading

- Clearing crews may cross waterbodies once, prior to installing equipment crossings.
- Contractors will install flume pipes, portable bridges, or timber mats as necessary, in the streambed for the equipment crossing in order to maintain the existing flow and course of the waterway.
- Contractors will implement erosion and sedimentation controls, and bank stabilization procedures at all stream banks.

#### Trenching/Lowering-in/Backfilling

- If mainline ditching crews excavate water body crossings, all facets of the installation (ditching, lowering-in, backfilling, and restoration) will be completed as soon as possible. If ditching, lowering-in, backfilling, and restoration of the



water body crossing cannot be completed in a timely manner, a site specific design for the crossing will be completed.

- Where blasting is required, the banks of the water body are to be left intact (hard plugs). If soft plugs must be installed, then the pipe installation shall be completed as soon as possible upon completion of the blasting.
- Contractors will use a backhoe or dragline to excavate the trench across the water body. Equipment used to dig the trench will work from the stream banks, equipment crossings, or by straddling the trenchline where the width of the water body prohibits excavations solely from the banks. The depth of trench will be sufficient to allow a minimum of 1.5 meters of cover over the pipeline below the streambed, unless otherwise specified.
- Where necessary, the grade of the stream banks will be reduced to form a gradual slope and soil will be pushed or pulled away from the water body to minimize siltation.

#### Cleanup/Restoration

- Stream channels will be backfilled, re-contoured and restored immediately.
- During restoration, flume pipes, sand bags and other material used for the water body crossing will be removed and the stream bottom and banks will be restored to their preconstruction contours or better to the extent practicable.
- Equipment crossings will be left in place as long as they are needed for access, then removed at the end of construction.
- Jute thatching or other erosion control matting will be used to stabilize stream banks where necessary.

**Method II: Other (Site-Specific Crossings).** Procedures for crossing rivers, ponds and lakes which cannot be crossed by Method I will be developed on a site specific basis.

**Combined Wetland/Water Body Crossings.** Wetlands and waterbodies are commonly found together as one ecosystem. The crossing methods used will be based on field conditions to protect both resources equally. It is essential to recognize that individual construction methods will be assigned to both the wetland and the water body to protect the resources. For complex systems, site-specific crossing methods will be designed.

### **3.5.2.5 Restoration and Revegetation**

Restoration and revegetation of the pipeline right-of-way includes permanent erosion and sediment control measures. However, in the event that final restoration cannot occur, temporary erosion and sediment control measures will be employed until the weather is suitable for final cleanup. Stabilization measures shall be initiated as soon as practicable on those portions of the right-of-way where activities have temporarily or permanently ceased. Permanent restoration and revegetation measures will serve to control erosion and sedimentation.

- All construction debris shall be removed from the right-of-way, and the right-of-way shall be graded so that the soil is left in the proper condition for planting.
- Where trench compaction has not been done, the right-of-way shall be graded to pre-construction contours, as practical, with a small crown of soil left over the ditch to compensate for settling, but not to interfere with natural drainage.
- Where topsoil has been segregated, the topsoil shall be spread back along the right-of-way in an even layer.
- All fences which were cut and replaced by gaps during construction shall be repaired to at least the equivalent preconstruction conditions.

- The right-of-way will be seeded and fertilized in the sandy Aeolic plain near the San Miguel river in accordance with applicable seed mixes and seeding dates.
- Slopes steeper than 3:1 shall be seeded immediately after final grading in accordance with recommended procedures and seeding dates, weather permitting.
- Mulching will be used as needed to assist in controlling erosion and establishing revegetative cover. Mulch will not be used in wetlands, or in agricultural (crop) areas.
- Temporary safety fences shall be erected at right-of-way crossings where necessary, to maintain a safe workplace.
- The access road will be restored to pre-construction conditions, or better unless specified by the landowner.
- If subsoils are unstable, corduroy paths (log, rip-rap or timber matting) may be needed. These materials will be removed during clean-up.

### **3.5.2.6 Spill Prevention and Control**

Contractors are responsible for implementing and maintaining spill control measures to prevent spills and measures which should be taken should any spills occur.

The Contractor will instruct construction personnel on the operation and maintenance of construction equipment to prevent the accidental discharge or spill of fuel, oil, lubricants, or other potential hazardous materials. Personnel will also be made aware of the pollution control laws, rules, and regulations applicable to their work. Spill prevention briefings with the construction crew will be scheduled and conducted by the Environmental Inspector at intervals frequent enough to assure adequate understanding of spill prevention measures.

The Contractor will inspect and maintain equipment that must be fueled and/or lubricated according to a strict schedule. All containers, valves, pipelines, and hoses will be examined

regularly to assess their general condition. The examination will identify any signs of deterioration that could cause a spill and signs of leaks, such as accumulated fluids. All leaks will be promptly corrected, and any leaking equipment will be promptly repaired. Spill kits with a capacity of absorbing 20 liters of liquid will be provided on construction equipment.

The Contractor will assure that all equipment is refueled and lubricated within the right-of-way and at least 15 meters away in any direction from all waterbodies and wetlands, except as otherwise approved. In approved areas, auxiliary fuel tanks will be used to reduce the frequency of refueling operations, and in no case will refueling take place within 30 meters of any known potable water wells.

The Contractor will prepare a pre-job written inventory of lubricants, fuel, and other materials which could be accidentally discharged during construction. Storage containment areas will not have drains, unless such drains lead to a containment area or vessel where the entire spill can be recovered. In case of a spill, the Contractor or utility inspector will notify the appropriate Environmental Inspector and construction supervisors.

If the Environmental Inspector determines that a spill is small enough such that the construction crew can safely handle it, the crew will containerize all spilled material, contaminated soil, and absorbent material in a manner consistent with the spilled material's characterization. If the Environmental Inspector determines that a spill cannot be adequately excavated and disposed of by the construction crew alone, the Contractor will follow procedures outlined in the Waste Management Plan.

The Contractor will prepare a Construction Site Spill Report form to be given to the Environmental Inspector that includes the following details of the incident:

- the date, time and location of the occurrence;
- a description of the material spilled;
- the quantity spilled;
- the circumstances that caused the spill;
- a list of waterbodies affected or potentially affected by the spill;

- a statement verifying whether a sheen is present;
- the size of the affected area;
- an estimate of the depth that the material has reached in water or on soil;
- a determination of whether the spill will migrate off the right-of-way;
- a determination of whether the spill is under control;
- a statement verifying that clean-up has begun and a description of the methods being used to clean up the spill.

For all spills including those handled by the construction crew, the Contractor will prepare a list of the type, quantity, and location of storage or containment and clean up equipment to be used on the construction site. The list will also include the procedures and impact minimization measures to be used in response to a spill. The Contractor's choice of mitigation measures and equipment will be tailored to meet the characteristics of the affected terrain as well as the types and amounts of material that could potentially be spilled. All spills will be cleaned up immediately.

The potential for large spills exists wherever fuels and hydraulic fluids are stored. The Contractor will take precautions in areas where trucks carrying fuel and oil barrels are loaded and will implement special measures to prevent spills in these areas. Containment equipment will be kept close to tanks and barrels to minimize spill response time and will include absorbent pads or mats. The quantity and capabilities of the mats will be sufficient to capture the largest foreseeable spill, given right-of-way characteristics and crankcase and other fuel vessel capacities.

For each water body and wetland crossed, equipment to remove oils from water, such as oleophilic and hydrophobic absorbent booms and mats, and/or mechanical skimmers will be stored close to the water body or wetland to minimize response time.

### **3.5.2.7 Waste Management**

**Planning.** A site-specific Waste Management Plan will be developed for the project. The purpose of the plan is to provide guidance in the management of materials and wastes to minimize any

adverse impact to the environment, limit risk exposure and ensure compliance with host country regulations. The plan will be designed to assist in:

- Identifying and classifying materials and wastes;
- Appropriately managing materials during use;
- Minimizing the generation of wastes to be treated and/or disposed;
- Selecting appropriate treatment/disposal alternatives;
- Documenting all aspects of the waste management process; and
- Ensuring regulatory compliance in waste management practices.

The fundamental concepts to be included in the plan are as follows:

- Project environmental management system or policy
- Regulatory requirements in Bolivia and Brazil
- Identification of waste streams
- Waste characterization
- Waste inventory procedures
- Waste minimization
- Waste handling
- Waste tracking and transportation
- Disposal Options

**Construction.** During construction, wastes will come from the personnel camps, construction materials, fuels, pipe preparations, and other sources. Worker camps will produce appreciable amounts of domestic garbage, which will be properly disposed of in approved landfills or landfills constructed by the project in accordance with applicable regulatory guidelines. Construction equipment will produce residual wastes such as waste oils and lubricants, filters, batteries, and scrap parts. There will also be steel scraps and dunnage left over from the pipeline assembly process.

Domestic waste waters from construction camps will be appropriately disposed of in field absorption and septic tank systems. The soil conditions expected should facilitate the use of such

systems for sanitary wastes. Equipment holding fuels and cleansers and solvents used in maintenance operations will be sited away from rivers and streams to avoid access to surface water in the event of an accidental spill.

**Operations.** Some wastes will be generated during the operations phase of the project. Office and domestic refuse will be disposed of in an existing approved sanitary landfill or in a landfill constructed by the project during the construction phase.

The compressor stations will not discharge any processed liquids into the surrounding environment. Gas turbines will require oil changes at infrequent intervals, perhaps no more often than every five years. When an oil change is required, the used oil will be collected and temporarily stored on site in appropriate containers, until disposal at an approved facility can be scheduled. Cleansers and solvents may be used on a limited basis for the routine cleaning of equipment and parts. No significant quantities of cleansers or solvents, or solutions containing cleansers or solvents will be generated. Any such wastes will be properly disposed of in accordance with the Waste Management Plan. The compression process will also generate small amounts of condensate liquids. This liquid will be collected in metal drums or tanks for storage until it is transported to an authorized disposal facility or recycled.

### **3.5.2.8 Environmental Inspection**

The project will use at least one qualified Environmental Inspector (EI) per construction spread. Training of the Environmental Inspectors will be undertaken to ensure 1) that they will be able to carry out their assigned duties, 2) that construction activities will be in compliance with the Environmental Construction Plan, and 3) that the project will be in compliance with requirements of the environmental license. The Environmental Inspectors will review all Project documents (right-of-way descriptions, permits, alignment sheets, aerial photography and relevant plans) prior to construction. A partial list of the primary responsibilities of the Environmental Inspectors is as follows:

- ensuring that all construction activities occur within authorized work areas and only approved access roads are used;

- ensuring that the requirements set forth in the Spill Prevention Containment and Control Plan are met;
- monitoring waste collection and disposal;
- inspecting construction activities daily to verify and document that Contractors are complying with the requirements of the Environmental Construction Plan, the environmental provisions included in the construction drawings and construction line list, the environmental conditions and mitigation measures in the Environmental Impact Study, and with all applicable permits and licenses;
- monitoring hydrostatic test fill and spill;
- working directly with the Contractor to assure that water body and wetland crossing plans are properly implemented; and
- maintaining daily activity logs, preparing weekly progress reports, and other required documentation of construction activities;

The Environmental Inspector will be required to use best judgment in the field at all times to ensure that violations, agency notifications, audits, and other environmentally related documentation are transmitted to the appropriate project management personnel. Each EI will have peer status with the other inspectors. The EI is responsible to report all non-compliance problems.

### **3.5.3 Operation**

Upon completion of start-up testing, the pipeline, compressor stations and related equipment will be commissioned for operation. Throughout the operation of the pipeline, the system will be inspected and maintained to ensure continuous operation. A detailed preventive maintenance and inspection program will be initiated and continued throughout the life of the project. On a prescribed schedule the entire right-of-way will be surveyed by air and land to check for pipeline



leaks and the operational condition of equipment. Preventive and corrective maintenance will be performed on valves and mechanical equipment. The historical log of test station readings from the cathodic protection will be analyzed to assure corrosion protection.

Block valves will be placed every 20 to 60 kilometers along the pipeline depending on the sector and the specified spacing in applicable design codes. Their function is to intercept gas flow by isolating a sector between valves in an emergency. The operation of these valves may be either automatic, fully manual, or controlled from the master control center in Santa Cruz. Selection and placement of valve operators will be part of the detail design.

Measurement and custody transfer of the gas transported in the pipeline system will occur at two points in Bolivia (Río Grande Gas Plant and the Bolivia/Brazil border). The metering will be done using orifice or turbine meters and an in-line gas chromatograph. A flow computation system, calibrated according to adopted standards, will be used to calculate the commercial volume of gas transported. These data will be transmitted to a central control center located in Santa Cruz.

The information sent to the control center will be processed by a SCADA (Supervisory Control and Data Acquisition) computer system. To transmit data from each compressor station, meter station and other monitored locations, the system will use a telecommunications system with radio transmission.

The system design will provide communications for the construction and operating phases. The system will be the link between the field offices, the field crews and the project management offices, and between the management offices. The telephone service will be used where available and practical, as well as a UHF system with repeaters along the route. In the operating phase a data network will be added for the SCADA system as well as a voice system for the compressor stations.

Most of the equipment installed in the construction phase will be retained for the operating phase. The operators of the control center will receive information from the field computational system and can call up information about pressures, temperature, flows and valves and have it displayed on high-resolution color monitors and send commands to control the installations remotely. All

the installations will have manual controls in case of a breakdown of communications to any of the control centers.

The SCADA system includes each remote installation, the compressor installations, the metering stations, and remote valve monitoring installations. They are integrated in a network, permitting the users to access data from any part of the system. The field electronic data are processed locally and transferred to the central computer. From the control center there is a fully automated remote control function for operation of the compressor stations. Mechanical equipment will be remotely started and stopped to meet variable demand throughout the day.

On an as-needed basis, the pipeline will be pigged to remove debris and liquids that might have accumulated during operation of the pipeline. Should the analysis of operating data justify the need, a smart pig can be passed through the pipeline to gather information, otherwise unavailable, to ensure the safe continuous operation of the system.

As each compressor station site is installed, the land will be cleared, graded and compacted, access roads constructed and the site boundaries fenced. Mechanical equipment will be installed and support facilities will be constructed above ground. Electric power and water from a public service are not available. Therefore, a diesel or natural gas fired electric generator will be installed to supply the necessary electric power at each compressor station, and a water well will be drilled at each site to supply water.

On-line compressor stations will function as a headquarters for operating personnel. The stations will provide offices, maintenance shops, communications and other amenities required to perform the functions of maintenance. Field operations will be dispatched locally from the compressor stations.

Atmospheric emissions in the operation phase may come from equipment and vehicles, gas leaks and purges or venting of the pipeline. Vehicle emissions during operation will be negligible due to the low traffic levels. Some gas emissions will be produced by combustion of natural gas in the turbines at compressor stations. As needed to meet Bolivian air emission limitations, the turbines will be equipped with low-emission burners which have less than half the NO<sub>x</sub> levels of

conventional equipment. Aside from NO<sub>x</sub>, this equipment will also emit low levels of carbon monoxide and unburned hydrocarbons. Other emissions of lesser importance are 1) from the power generator exhaust; 2) from gas used to start up the turbines; and 3) from when the compressor station is vented during emergency shut down of the gas supply. The gas pipeline is designed to be a closed system, and it is expected that leaks will be small or nonexistent. Leaks due to pipeline breaks are possible, but highly unlikely. Any breaks will be repaired immediately. Some loss of natural gas would occur when the line is evacuated in the event of an emergency shut down. Since gas is lighter than air, it will rise and dissipate quickly without forming a gas cloud near the ground.

In the case of an emergency shutdown of one compressor station, the suction and discharge side valves (which are the inlet and outlet valves of the compressor station) will be automatically closed to isolate the compressor station piping from the main pipeline, and the compressor station piping will be vented to atmosphere.

A contingency plan will be developed to outline the course of action to be taken given certain emergency situations.

#### **3.5.4 Abandonment**

Once gas is no longer transported in the pipeline, the pipeline will be abandoned. Both ends of the pipeline will be disconnected and every opening will be closed and sealed.

In places where the pipeline is subject to pressures or external forces, such as those caused by geologic fault sites or landslides, the pipe will be sealed at the ends, and if possible inert material from the area will be used to fill the pipe.

### **3.6 HUMAN RESOURCES**

For field work and camp operations approximately 2,000 employees will be required, including camp personnel. The work force will be comprised of expatriates and Bolivian national employees. Every effort will be made to maximize the employment of Bolivian nationals.

Installation and maintenance of fiber optic cable would increase labor requirements by 2-8 operators and 8-16 laborers. Crews would be required for termination and splicing, and installation of termination/splicing facilities. Craftsmen such as equipment operators, mechanics, welders, truck drivers, laborers, chefs, camp service personnel, medics, engineers, and office personnel will be employed. The average time of employment in the field operations will be ten (10) months. These employees will be working at pipe storage yards and operations related to construction of all facilities, i.e. pipeline, compressor station, storage yards and road upgrades. The number of people to be employed at any time will be determined by the nature of the activity. In all cases, qualified local personnel will receive first consideration for employment.

### 3.7 SAFETY

**Safety Conditions.** Safety is a primary concern of the project. The emphasis on safety has been and will remain a focus in all development plans covering the entire life of the project, from preliminary design to operation and maintenance. The main objective is to operate accident free throughout the project, including contractors, consultants, residents, and third party workers.

The gas pipeline will be designed, built, operated and maintained in accordance with Bolivian and international norms and standard accepted engineering practices to properly protect the public in the event of a failure. This will be accomplished by specifying the choice and ratings of materials, minimum design requirements, and corrosion protection.

Safety meetings will be held periodically involving all personnel. The construction phase involves among others, movement of personnel, equipment and material to the work areas. The following is a list of activities where safety procedures will be established before construction:

- individual safety organization/orientation;
- operation of construction equipment;
- operation of vehicles;
- procedures in case of vehicle accident;
- safe driving;
- safety in handling tools and equipment;

- safety in use of explosives;
- risks communication program;
- removal of structures;
- clearing of right-of-way;
- cutting and welding;
- storehouses and shops for equipment and tools;
- leveling operations;
- transport; unloading and placement of pipe;
- ditching; pipe bending;
- cleaning and coating pipe;
- crossing roads and water bodies;
- hydrostatic testing; and,
- backfill and cleanup.

**Safety Training.** Safety training will be done in groups for construction personnel and inspection personnel prior to construction. Weekly safety meetings will be held for all personnel throughout the construction period.

Project management will place great emphasis on worker safety throughout all phases of the project. During operation, there will be a rigorous system of field inspections and evaluation of the control system. In case of gas leaks, it is difficult to reach explosive or asphyxiating levels since gas is lighter than air. The explosive levels are 5-15% gas/air and ignition temperature is 540 °C.

The project will develop and sustain various response plans to incidents that may affect the line. All repairs of the line will be done pursuant to Bolivian standards.

In case of minor losses, the system will be shut down for repair or a neck weld will be installed to close the system. In case of major losses, the system will be shut down completely to replace the damaged joint. New sections must undergo a hydrostatic test.

In case of major level losses, the system will be shut down automatically from the central control room. Pipeline transport of natural gas involves a very low level of risk to persons in the event of an accident and/or leaking gas. The greatest risk is a fire or explosion if the pipe is ruptured.

**Safety Standards.** The following minimum safety standards will be developed to protect human life and safeguard the public from real or potential risks.

- Establishment and maintenance of communications to coordinate speedy response to emergencies.
- Provision of properly trained personnel, equipment, tools and materials necessary in a site with an emergency.
- Cut off service in an emergency and restore it safely.
- Maintain close communications to coordinate resources and update awareness of the responsibilities of each organization in case of an emergency.
- Establish continuing education programs to enable the general public, governmental officials, and excavators to recognize emergencies in the pipeline system and report to the proper authorities.

### **3.8 BOLIVIA-BRAZIL FIBER OPTIC SYSTEM**

#### **3.8.1 Project Background**

The Bolivia-Brazil Gas Pipeline partnership is evaluating the opportunity to install fiber optic cable/conduit facilities along the natural gas pipeline route. This project is being evaluated from two perspectives. First, the facilities would be utilized as part of a communications venture, selling capacity to interested companies to generate additional revenues for the pipeline partnership.

### 3.8.2 Project Justification

The facilities would be installed to serve the pipeline communication requirements if it is determined that this is the least-cost transmission strategy, given the conditions present in Bolivia and Brazil. Additional justification would be the presence of market demand for excess capacity on the facilities, in order to generate additional revenues. Determination as to the viability of this project will be based upon a complete analysis of the pipeline requirements, the available technology in both countries, the cost for installation of the facilities, the potential market demand along the pipeline route for communications capacity, and the regulatory feasibility of such a venture.

### 3.8.3 Description

**Route.** The proposed fiber optic system will run eastward from Santa Cruz, Bolivia, to Campinas, in the State of São Paulo, Brazil for a total distance of approximately 1,800 kilometers. From the Río Grande Gas Plant (approximately 40 kilometers southeast of Santa Cruz), the cable will be laid in the same ditch as the Bolivia-Brazil Gas Pipeline, running 567 kilometers east to the border with Brazil. From the border, the cable will continue within the pipeline right-of-way 1,233 kilometers in an east-southeast direction to Campinas, to later serve large metropolitan areas.

**Cable Characteristics.** For this particular installation, AT&T DRX Lightguide Express Entry (LXE) Lightpack, long haul cable has been selected. The company might select to install PVC conduit within the pipeline ditch, in which the cable will be installed. This cable consists of multiple single mode fibers and is designed for easy handling and sheath entry. This design provides both lightning and rodent protection. The fibers are separated into color-coded binder groups (12 fibers each), surrounded by a polymetric core tube which is filled with a water-blocking compound. This LXE design has an overlapped armor of stainless steel that envelopes the core tube and has a ripcord under it to facilitate removal. Two steel wires run longitudinally along the armor, diametrically opposite each other. Two ripcords are located next to the steel wire strength members for easy sheath removal. The outer sheath jacket is High-Density Polyethylene (HDPE) for ruggedness and ease of installation. This design is suitable for use in underground conduit, direct burial, or aerial applications. The small size and light weight make installation

relatively easy. The LXE design complies with U.S. industry standards, such as EIA and Bellocore.

**Technical specifications:**

- Tensile load rating: 600 pounds (2,669N)
- Minimum bending radius: 10 X diameter (no load)  
20 X diameter (loaded)
- Outside diameter: 0.61 inch (15.5 mm)
- Weight: 150 pounds per 1,000 feet (223 kg/1,000m)
- Operating temperature range: -40° F to 158° F (-40°C to 70°C)
- Reel capacity: 6,000m
- Attenuation: 0.35 db/1000 m @ 1,310 nm  
0.23 db/1000 m @ 1,550 nm  
(Dual wave length)

**Construction Schedule.** The construction schedule for the fiber optic system will follow the same schedule which has been developed for the gas pipeline construction in Bolivia.

Above ground appurtenant facilities will be constructed (as required by the system design) after completion of the pipeline backfill/cleanup operation, but prior to the compressor station commissioning phase.

**Logistics, Personnel, and Equipment Requirements.** Material and equipment items required for construction of the fiber optic system will be received in-country from various international and/or local sources. The same entry ports used for receipt of pipeline-related material will be utilized. Off-loading, customs clearance, transport to the right-of-way and site storage will be accomplished similarly as with pipeline-related construction materials. Existing pipe storage yards, strategically located along the right-of-way, will be utilized for storage of the fiber optic system related materials, and will require minimal additional ground space over and above that already allocated for storage of pipeline related materials.



Based on the total route mileage for the fiber optic system, a total of about 102 cable reels will be required in Bolivia. Each reel will weigh about 3,000 pounds (1,364 kg).

Most materials (primarily hardware) to be used for repeater station construction will also arrive from various international and/or in-country locations and will be containerized for shipment. It is anticipated that approximately eight repeater stations will be required for the Bolivian sector, based on a 45 to 60 mile (72 to 95 km) maximum spacing. Station hardware, in containers, will be stored at existing pipe storage yards, along with cable reels. Two (2) containers per station will be required, not including building materials, civil, foundation and expendables which will be acquired on the local market and transported to a particular station site by local means.

Since fiber optic system construction will track the pipeline construction, it is envisioned that all personnel involved in installation of the fiber optic system will reside in construction camps dedicated for the pipeline construction crews.

Small pull boxes ( $\frac{1}{2}$  square meter) for splices will be installed, flush with grade approximately every four to five kilometers.

**Employment Requirements.** Since installation of the fiber optic system will closely track the pipeline installation activities, it will be necessary to match cable installation crews with pipeline construction spreads. Two (2) mainline construction spreads and one (1) river crossing spread will be involved in construction of the pipeline in Bolivia, plus separate fly crews dedicated to road, rail, and river crossings. It will be necessary to man each spread with a cable installation crew which will consist of six to eight people, including supervision (not including Company supervision). Construction of repeater stations will require an additional four to six people per station, and will occur after cable installation. This results in peak manpower loadings of 18-24 personnel for cable installation and about 48-64 personnel for station construction.

**Abandonment Procedures.** Should it become necessary to abandon the fiber optic system, the cable will be left in place to minimize environmental impacts associated with removal from the pipeline ditch.

Aboveground facilities (e.g., repeater stations) may be demolished and the site restored to pre-existing conditions.

TABLE 3.1 MAIN CHARACTERISTICS OF THE PROJECT																															
Design and Operation Pressures	ANSI 600.																														
Pipe Specification	API 5L Grade X-70																														
Project Life	20 years																														
Duration of Construction	10 months																														
Characteristics of the gas	Composition: <u>Components</u> <table style="margin-left: 20px;"> <thead> <tr> <th></th> <th style="text-align: right;"><u>% Molar</u></th> </tr> </thead> <tbody> <tr> <td>Methane</td> <td style="text-align: right;">91.80</td> </tr> <tr> <td>Ethane</td> <td style="text-align: right;">5.58</td> </tr> <tr> <td>Propane</td> <td style="text-align: right;">0.97</td> </tr> <tr> <td>i - Butane</td> <td style="text-align: right;">0.03</td> </tr> <tr> <td>n - Butane</td> <td style="text-align: right;">0.02</td> </tr> <tr> <td>Pentane and Greater</td> <td style="text-align: right;">0.10</td> </tr> <tr> <td>Nitrogen</td> <td style="text-align: right;">1.42</td> </tr> <tr> <td>Carbon Dioxide</td> <td style="text-align: right;">0.08</td> </tr> </tbody> </table> Physical Properties: <u>Property</u> <table style="margin-left: 20px;"> <thead> <tr> <th></th> <th style="text-align: right;"><u>% Molar</u></th> </tr> </thead> <tbody> <tr> <td>Molecular Mass</td> <td style="text-align: right;">0.600</td> </tr> <tr> <td>Specific Gravity</td> <td style="text-align: right;">9269</td> </tr> <tr> <td>Higher Heating Value (Kcal/m<sup>3</sup>)</td> <td style="text-align: right;">9269</td> </tr> <tr> <td>Lower Heating Value (Kcal/m<sup>3</sup>)</td> <td style="text-align: right;">8364</td> </tr> <tr> <td>Absolute Viscosity (centipoise)</td> <td style="text-align: right;">0.011</td> </tr> </tbody> </table>		<u>% Molar</u>	Methane	91.80	Ethane	5.58	Propane	0.97	i - Butane	0.03	n - Butane	0.02	Pentane and Greater	0.10	Nitrogen	1.42	Carbon Dioxide	0.08		<u>% Molar</u>	Molecular Mass	0.600	Specific Gravity	9269	Higher Heating Value (Kcal/m <sup>3</sup> )	9269	Lower Heating Value (Kcal/m <sup>3</sup> )	8364	Absolute Viscosity (centipoise)	0.011
	<u>% Molar</u>																														
Methane	91.80																														
Ethane	5.58																														
Propane	0.97																														
i - Butane	0.03																														
n - Butane	0.02																														
Pentane and Greater	0.10																														
Nitrogen	1.42																														
Carbon Dioxide	0.08																														
	<u>% Molar</u>																														
Molecular Mass	0.600																														
Specific Gravity	9269																														
Higher Heating Value (Kcal/m <sup>3</sup> )	9269																														
Lower Heating Value (Kcal/m <sup>3</sup> )	8364																														
Absolute Viscosity (centipoise)	0.011																														
Transport Pressures	Initial pressure (Río Grande): 1, 420 psig Arrival pressure (Campinas): 1, 089 psig																														
Volume of Gas to be Transported	Initial: 8 MM CMD After seven years: 16 MM CMD Maximum capacity: 30 MM CMD																														
Pipe Characteristics	Diameter: 32" Thickness: 0.406-0.649 External coating: One of several alternatives of anti-corrosive coatings supplemented by a system of cathodic protection																														
Valve system	Automatic and manual																														
Pig launch and receivers	To be installed at the compressor and measuring stations																														
Compressor stations	1 in phase I; up to 4 to accommodate full capacity																														
Measurement stations	2.00																														

TABLE 3.2			
DESCRIPTION OF THE CAMP SITES IN SPREAD 1			
SITE NO.	LOCATION	SIZE	CHANGES TO AREA
1	- West side of Río Grande near gas plant	- 1.0 ha - 120 person max	- No need to clear additional area as there was sufficient previously disturbed area.
2	- Adjacent to the public road which traverses south from the town of Pailon, at approximately K.P. 12 on the pipeline route and on east side of the Rio Grande. - Also adjacent to the pipeline right-of-way.	- 3.2 ha - 600 person max	- Land will need to be cleared. - Drinking water and waste water facilities to be installed.
3	- At YPFB abandoned compressor station site.	- 3.2 ha - 600 person	- Although site is cleared and fully fenced, additional clearing will be done inside fence and clean up of existing small buildings and foundations. - Power generation equipment available with sufficient gas supply to fuel generators. - Existing water well available but additional well will be drilled for sufficient water supply. - Road which traverses site will be upgraded for project use, for pipe haul and other use to the pipeline right-of-way.
4	- On west side of the access road which traverses due south from San José de Chiquitos, and north of pipeline right-of-way.	- 3.2 ha - 600 person	- Clearing required. - Drilling of water wells and facilities for disposal of wastewater required.
5	- East side of road from Roboré (K.P. 311.5 on pipeline route) and south of pipeline right-of-way. - Site adjacent to both pipeline right-of-way and upgraded access road.	- 3.2 ha - 600 person	- Clearing required. - Water wells and wastewater disposal facilities required.

TABLE 3.3 DESCRIPTION OF THE CAMP SITES IN SPREAD 2			
SITE No.	LOCATION	SIZE	CHANGES TO AREA
1	- Same as Site No. 5 for western half of Bolivian pipeline area	- 3.2 ha - 600 person	
2	- South and east of the railway station and east of the cattle loading facility, 1.5 kilometers from right-of-way. - Site in conjunction with pipe storage yard at El Carmen.	- 3.2 ha - 600 person	- Clearing required. - Drilling water wells and installation of waste water facilities required.
3	- 15 kilometers South of Puerto Suarez at intersection of pipeline right-of-way and the road between Puerto Suárez and El Carmen de la Frontera. - East of the road and North of pipeline.	- 3.2 ha - 600 person	- Site previously cleared. - Water wells and waste water facilities required.

TABLE 3.4

DESCRIPTION OF STORAGE AREAS

SITE	LOCATION AND AREA OF SITE	AREA FOR STORAGE	DESCRIPTION OF STORAGE AREA AND ALTERATIONS	USE
Santa Cruz	<ul style="list-style-type: none"> <li>- Property of YPFB.</li> <li>- Site fenced with an area of 2.1 ha.</li> <li>- Railroad spur in place and with only 4.3 kilometers of pipe to be installed between YPFB Rio Grande Gas Plant and Rio Grande, this small amount of pipe will not be double jointed.</li> </ul>	0.6 ha	<ul style="list-style-type: none"> <li>- Previously used area and inside fenced area.</li> </ul>	<ul style="list-style-type: none"> <li>- The only required storage is for the above pipe and general supplies.</li> <li>- Double jointing pipe operations.</li> </ul>
Pailón	<ul style="list-style-type: none"> <li>- Site in an area of grain elevators used to receive soybeans and other grains for export shipment by railroad.</li> </ul>	6.25 ha	<ul style="list-style-type: none"> <li>- Storage area located behind two existing grain elevator sites.</li> <li>- Both areas have existing rail spurs into the sites and each will need to be extended only 300 m.</li> <li>- Area is cleared and used for planting soybeans or for pasture land.</li> </ul>	<ul style="list-style-type: none"> <li>- Supply pipe to the project east of the Río Grande to approximately K.P. 165.</li> <li>- Pipe storage, double jointing pipe operations and double jointing pipe personnel.</li> </ul>
San José de Chiquitos	<ul style="list-style-type: none"> <li>- Site will use YPFB petroleum product distribution site to off-load the pipes.</li> </ul>	5 ha	<ul style="list-style-type: none"> <li>- Storage area immediately adjacent to the east of YPFB facility.</li> <li>- Installation of two double gates in the YPFB fence line for ingress/egress necessary.</li> <li>- ENFE has many rail spurs in the vicinity of this station, which are never used. Project can utilize these spurs for storage of empty wagons waiting to be unloaded.</li> </ul>	<ul style="list-style-type: none"> <li>- Supply pipe from K.P. 165 to approximately K.P. 240.</li> <li>- Pipe storage and jointing operations.</li> </ul>

TABLE 3.4

DESCRIPTION OF STORAGE AREAS

SITE	LOCATION AND AREA OF SITE	AREA FOR STORAGE	DESCRIPTION OF STORAGE AREA AND ALTERATIONS	USE
Roboré	- Total pipe delivered here will be 6954 joints with approximately one-half of this amount being for each spread.	4 ha	- Area allowed is for one-half of the pipe being in yard at one time. (If one contractor is awarded both spread, this contractor can schedule his work accordingly so that the allotted space is sufficient for operation at this location. If the two spreads are awarded to two different contractors, the contract should stipulate that their respective work is not conducted simultaneously in this area under this scenario, this way both contractors are able to utilize this facility.	<ul style="list-style-type: none"> <li>- Supply pipe for spreads I &amp; II.</li> <li>- Pipe storage</li> <li>- Double jointing pipe operations.</li> </ul>
El Carmen	- Less than two kilometers from the right-of-way, therefore will be used as main construction camp as well as off loading pipe and double jointing operations.	7 ha.		<ul style="list-style-type: none"> <li>- Supply pipe and general supplies to the construction contractor.</li> <li>- Main construction camp</li> <li>- Double jointing operations.</li> <li>- Supply materials for compressor station to be constructed at K.M. 484 (near Palmito).</li> </ul>
Suárez Arana	- Located north and west of the train station.	3.5 ha.	- Site has sufficient rail spurs to be used for off loading of pipe.	<ul style="list-style-type: none"> <li>- Pipe and general supplies storage.</li> <li>- Double jointing operations.</li> <li>- Camp facilities for off loading personnel and double jointing personnel.</li> </ul>

TABLE 3.5

PIPE STORAGE YARD LOCATIONS AND REQUIRED AREAS IN BOLIVIA

STORAGE YARDS REQUIRED AREAS, BOLIVIA	QUANTITY OF JOINTS	PIPE STORAGE AREA (HECTARES)	DBJ JT PIPE STORAGE AREA (HECTARES)	DBJ JT YARD AREA (HECTARES)	CAMP SITE DBJ JT OPERATION PIPE LOADING (HECTARES)	MAIN CONSTRUCTION CAMP <sup>2</sup> (HECTARES)	GENERAL STORAGE (HECTARES)	COMPRESSOR STATION MATERIAL	TOTAL AREA (HECTARES)
Spread 1									
Santa Cruz	357	0.043	Lay 11.5m pipe	-	-	-	0.5		0.543 = 0.6
Pailón	13,991	1.666	1.45	0.92	1.1	-	1.0		6.156 = 6.25
San José de	9,044	1.09	0.85	0.92	1.1	-	1.0		4.96 = 5.00
Chiquitos	3,562	0.429	0.32	0.92	1.1	-	1.0		.769 = 4.00
Roboré <sup>1</sup>									
Spread 2									
Roboré <sup>1</sup>	7,092	0.429	.32	0.92	1.1	-	1.0		3.769 = 4.00
El Carmen	11,864	0.893	0.725	0.92	1.1	3.2 (2.1)	1.0		6.738 = 7.0
Puerto Suárez	2,434	0.983	0.725	0.92	1.1	3.2 (2.1)	1.0		6.828 = 7.00
		0.294	0.215	0.92	1.1	-	1.0		3.529 = 3.5

- (1) This yard to service both Spread 1 & 2. Both of these operations will utilize same camp.  
 (2) This area from the camp of load, unloading & double jointing will be incorporated into construction camp.

1 AC - 208 sq. ft.  
 Area = 43,264 sq. ft

32" Pipe = 0.89' wide  
 210 Jts./ROW

Add 1.0 Hectare at each storage site for items such as  
 containers, block valves, construction equipment, pipeline  
 supplies, etc.

1 Hectare - 100 sq. ft. m  
 = 328 sq. ft.  
 = 107,584 sq. ft.  
 2.47 AC - 1 Hectare

4 Rows - 840 JTS/Layer  
 x4 Layers = (Pipe Stacked 4 High)  
 3360 JTS/AC  
 2.47 AC/Hectare - 8299 JTS/Hectare

Total Hectares = 43.74



**TABLE 3.6**  
**SUMMARY OF ROADS TO BE UPGRADED IN BOLIVIA FOR THE GAS PIPELINE PROJECT**

LOCATION	DISTANCE OF ROAD TO BE UPGRADED	ALTERATIONS
- Portion of the road to Rio Grande Gas Plant starting at YPFB's refinery extending to gas plant.	52 kms	- Motor graders used to complete work on road which is basically gravel.
- Road to pipeline paralleling Rio Grande on east side, which commences at Pailon and traverses due south to the pipeline right-of-way.	75.7 kms	- Portion of road still requiring upgrading will be corrected with motor grader and bad spots repaired with backhoes, front end loaders, compactors, dozers and dump trucks.
- Road to Isla Verde, commencing from the road described above, 3 km south of Pailon. The road traverses in a south-easterly direction until it intersects with the "L" road which traverses south from the Tres Cruces region. It continues on the "L" road until it intersects with the pipeline road, by the abandoned compressor station terminating in the Isla Verde area.	125.5 kms	- Extensive motor grader and dozer work required. Loose material will be removed in severely deteriorated areas with backhoe and replaced with clean material and compacted. (Seventeen drainage ditches require 30" or 36" culverts which will be placed simultaneously with the road upgrade operation.)
- Road due south from San Jose de Chiquitos to the pipeline ROW commencing at YPFB petroleum distribution yard.	78.05 kms	- Portion of road will be widened at three sharp curves in the mountains. Culverts installed. - Filling of low areas, and cutting of brush and second growth timber. - Motor graders, dozers, front end loaders, backhoes, compactors and dump trucks will be used.

**TABLE 3.6**  
**SUMMARY OF ROADS TO BE UPGRADED IN BOLIVIA FOR THE GAS PIPELINE PROJECT**

LOCATION	DISTANCE OF ROAD TO BE UPGRADED	ALTERATIONS
- Road southwesternly from Roboré to pipeline right-of-way.	42.1 kms	<ul style="list-style-type: none"> <li>- Small river bridge in the first 8 kilometers will be reinforced to withstand the increased traffic brought about by the project construction. (The method is to drive a piling on each side of the bridge then weld a crossbeam to the driven piling immediately under the bridge deck.)</li> <li>- Another small creek bridge will be improved by removing the deck and replacing it with large diameter culverts and fill in over the culverts.</li> <li>- Section from Roboré to the intersection with the road to the right-of-way has several bad areas which will require excavating, filling with clean material and compacting, extensive motor grade work with dozer, front loader, backhoe, compactor and dump trucks; total distance improved - 19.5 km.</li> <li>- Section from road intersection of the Roboré- San Jose de Chiquitos road to the pipeline will be upgraded with motor grader. Two locations where large diameter culverts will be replaced with a 30" or 36" culvert and roadway reshaped. There are five locations where 20" diameter culverts will be installed; total distance improved - 22.6 kms.</li> <li>- Right-of-way grade operation involved on section from the road to the crossing of the Rio San Miguel. Temporary bridge may need to be installed at the Rio San Miguel to accomodate equipment movement along the right-of-way.</li> </ul>
- Road due south from El Carmen to right-of-way	1.5 kms	<ul style="list-style-type: none"> <li>- Trees will be removed to widen the road to allow for two-lane traffic, using a motor grader.</li> <li>- This road passes a cemetery on the east side and should consider rerouting the road straight south from storage yard to a point west and south of the cemetery.</li> </ul>
- Access from El Carmen/Puerto Suarez to Right-of-way at pipeline, approximately K.P. 530.	6.85 kms	<ul style="list-style-type: none"> <li>- Road improved with motor graders and D- 6 dozer.</li> </ul>

**TABLE 3.6**  
**SUMMARY OF ROADS TO BE UPGRADED IN BOLIVIA FOR THE GAS PIPELINE PROJECT**

LOCATION	DISTANCE OF ROAD TO BE UPGRADED	ALTERATIONS
- Access road from El Carmen/Puerto Suarez to right-of-way at pipeline, approximately K.P. 533.	5.75 kms	- Road improved with motor grader and one D-6 dozer.
- Road from Puerto Suarez to El Carmen Frontera	19.8 kms	- A motor grader to clean out ditches and reshape roadway in the first 14.2 kms required. - From this point to El Carmen de la Frontera, total distance of 5.6 kms, road will require excavating, replacing with good fill material and compacting, and installation of eleven 30" culverts at various locations along this 5.6 km section, requiring backhoes, motor graders, dozers, front end loader, compactors and dump trucks.
- Road between Puerto Suarez and El Carmen de la Frontera	100.6 kms	- Section between Puerto Suarez and Yacuces has a total length of 44.3 kms. This section will be upgraded at five locations which have depressions to ground level where a bridge or culvert was once located. Bridges or culverts will be replaced at each location. Many areas in the section between Yacuces and El Carmen will be excavated, fill imported and compacted. This 56.3 kilometer section will require 21 culverts of 30" diameter. Additional upgrading will be done with motor graders, backhoes, front end loaders, dozers, compactors, and dump trucks. Work will include installation, repair of bad areas with imported fill, establishing drainage ditches, cutting water turnouts and reshaping roadway.

TABLE 3.7 ROAD UPGRADES IN BOLIVIA DUE TO GAS PIPELINE PROJECT AND DISTANCE OVER WHICH CERTAIN EQUIPMENT WILL BE UTILIZED		
ROAD	DISTANCE - KILOMETERS	
	MOTOR GRADE ONLY	FULL COMPLEMENT EQUIPMENT
Santa Cruz to Y.P.F.B. Rio Grande Gas Plant	3	49
Pailon to Pipeline Right-of-Way, Parallelling East Side of Rio Grande	21	54.7
Pailon to Isla Verde	0	125.5
San José de Chiquitos to Pipeline R.O.W.	0	78.1
Roboré to Pipeline R.O.W.	19.3	22.8
Naranjos to R.O.W.	12.75	0
El Carmen to R.O.W.	1	1
Access to R.O.W., West Side Cañon de la Victoria	6.85	0
Access to R.O.W., East Side Cañon de la Victoria	5.75	0
Road, Puerto Suárez to El Carmen Frontera	14.2	5.6
Road, Puerto Suárez to El Carmen	44.3	56.3
Total	128.15	393.0

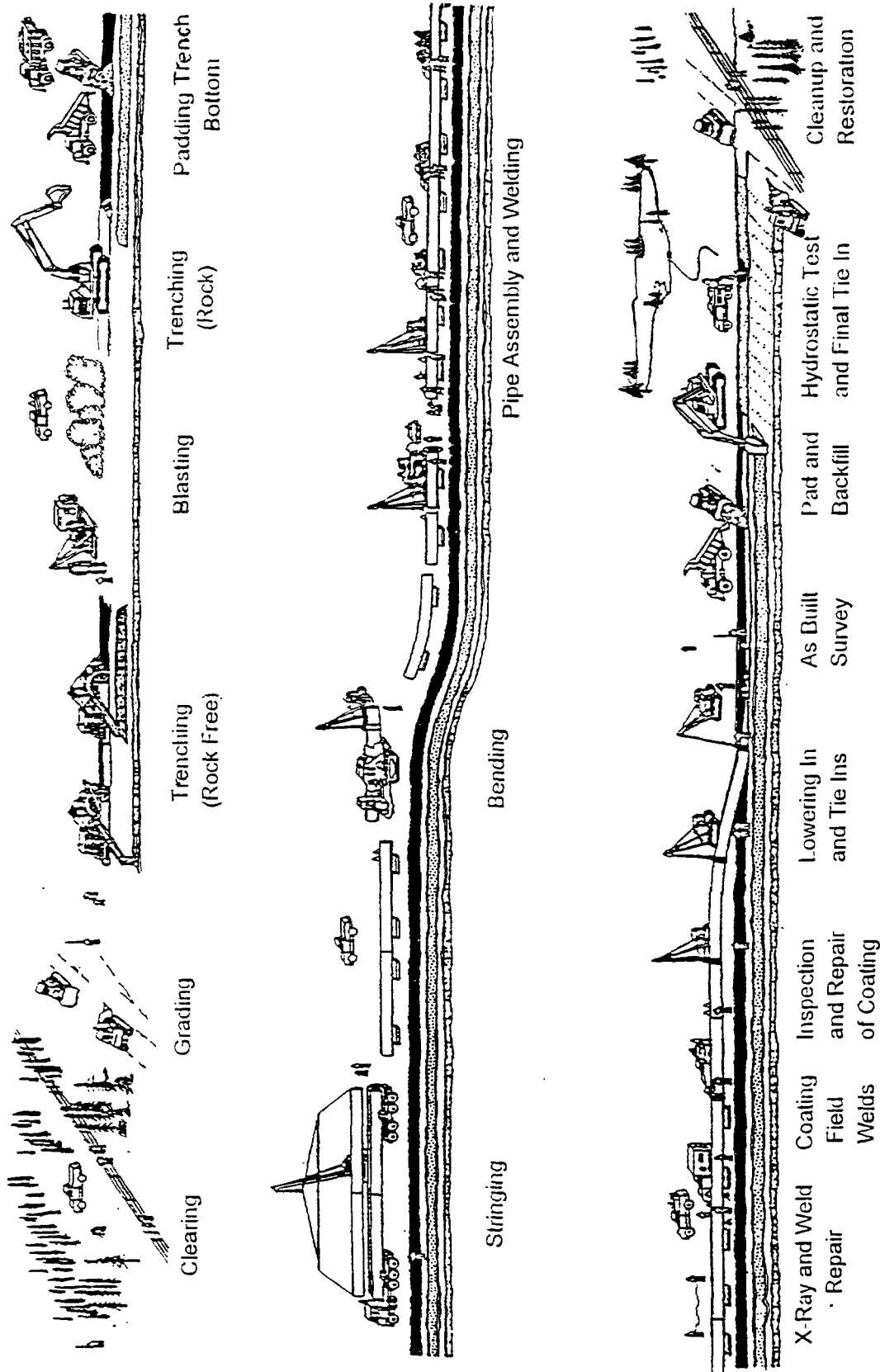

BOLIVIA TO BRAZIL GAS PIPELINE (BOLIVIAN PORTION)  
 TYPICAL PIPELINE  
 CONSTRUCTION SEQUENCE



FIGURE 3.1

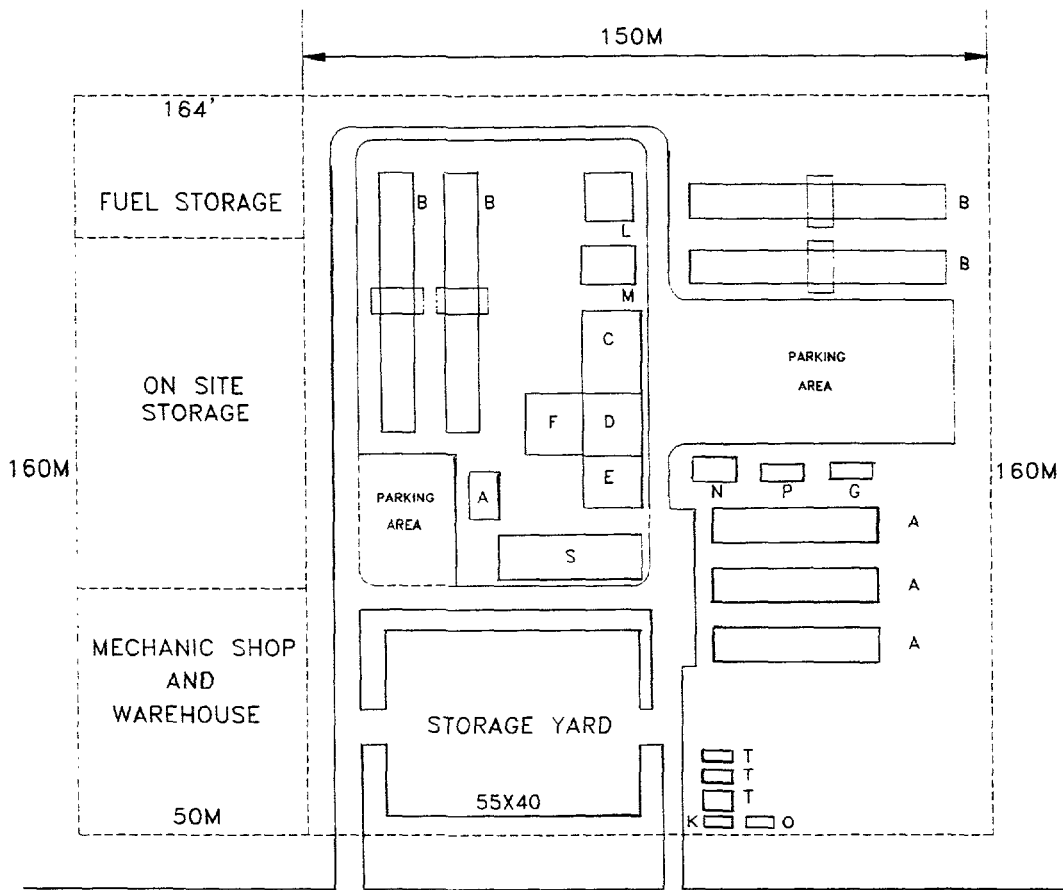

- A-SLEEPERS EXP. SINGLE ROOM W/BATH TOTAL=72MEN
- B-SLEEPERS NAT. 4 EA ROOM 128 MAN TOTAL=512MEN
- C-DINING NAT. 50'x120'
- D-KITCHEN
- E-DINING EXPAT.
- F-COLD\DRY STORAGE
- G-MEDIC. NAT.
- L-LAUNDRY
- M-RECREAT. NAT.
- N-RECREAT. EXPAT.
- P-LAUNDRY EXPAT.
- J-SEWER PLANT
- K-WATER PLANT
- T-GENERATOR
- S-SITE OFFICE

AREA=160MX200M=32,000M<sup>2</sup>  
 ≈3.2 HECTARES  
 (7.90 ACRES)

BOLIVIA TO BRAZIL GAS PIPELINE (BOLIVIAN PORTION)

PROPOSED PLOT PLAN  
 FOR A 800 MAN  
 CAMP SITE TYPICAL

 **Dames & Moore**

FIGURE 3.2

- A-SLEEPERS EXP. SINGLE ROOM W/BATH TOTAL=72 MAN
- B-SLEEPERS NAT. 4EA ROOM 128 MAN TOTAL =512 MAN
- C-DINING NAT. 50'X120'
- D-KITCHEN
- E-DINING EXPAT.
- F-COLD/DRY STORAGE
- G-MEDIC EXPAT. AND NATIONAL
- M-RECREAT NAT.
- N-RECREAT EXPAT.
- P-LAUNDRY EXPAT. AND NATIONAL
- J-SEWER PLANT
- K-WATER PLANT
- T-GENERATOR
- S-SITE OFFICE

AREA=160X70=11,200M<sup>2</sup>  
 =1.1 HECTARES  
 (2.72 ACRES)

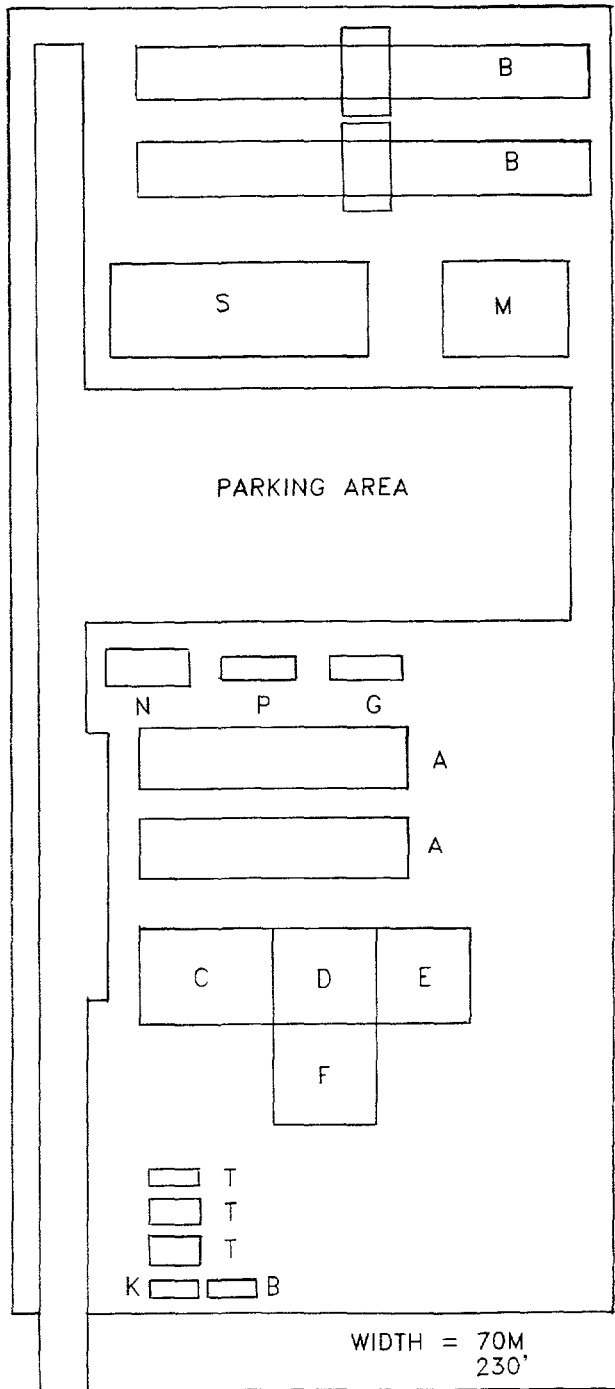

BOLIVIA TO BRAZIL GAS PIPELINE (BOLIVIAN PORTION)

PROPOSED PLOT PLAN FOR  
 120 MAN CAPACITY (OR LESS)  
 CAMP SITE TYPICAL



FIGURE 3.3

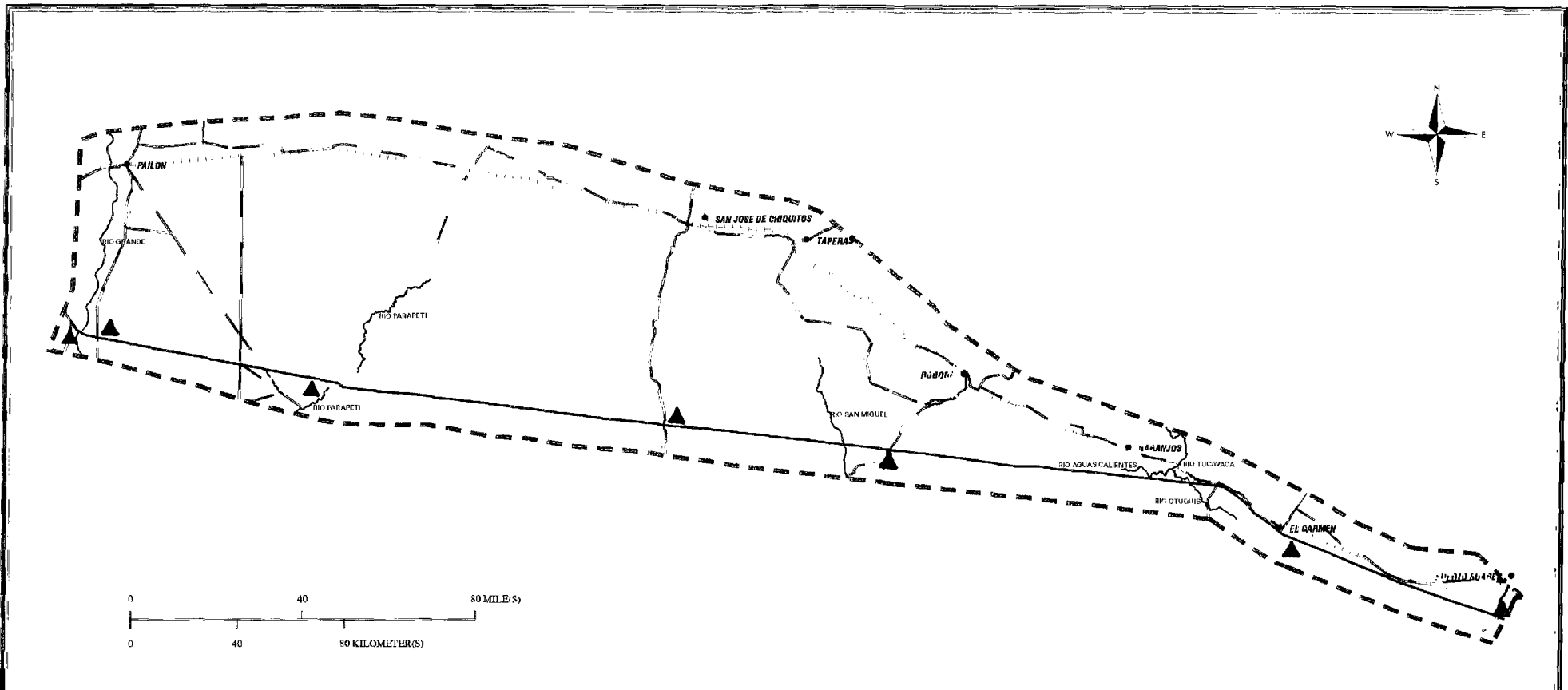

### Legend

- |   |   |
|---|---|
|  Major Roads |  Rivers       |
|  Railroad    |  Gas Pipeline |
|  Study Area  |  Major Towns  |
|   |  Camp Sites   |

### Bolivia to Brazil Gas Pipeline (Bolivian Portion)

Location of Camp Sites

Spread 1 & 2

Figure 3.4



DAMES & MOORE



PIPE STORAGE AREA BERMS  
TYPICAL FOR ALL STORAGE AREAS.

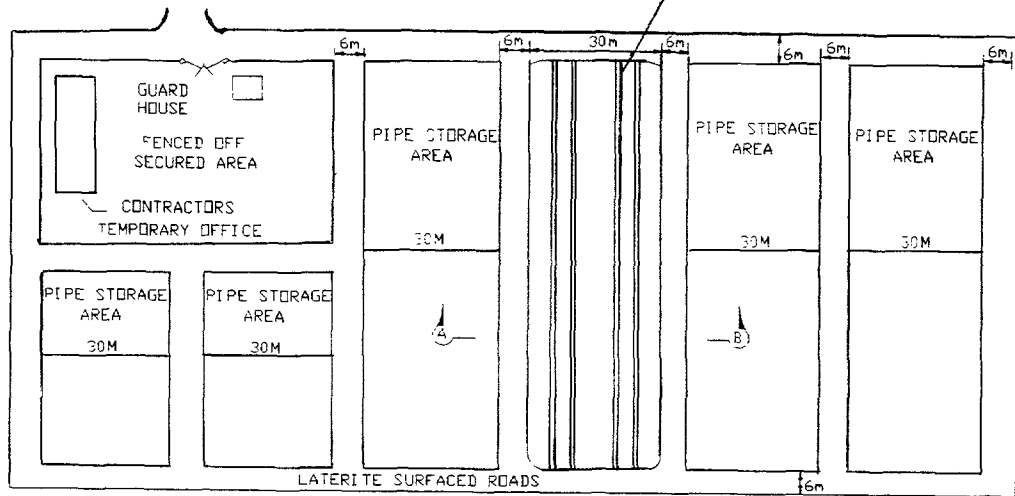

PLAN

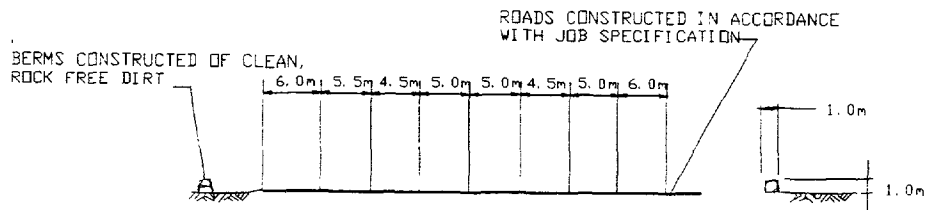

SECTION A-A

NOTE: DRAINAGE TO BE INSTALLED. CULVERTS TO BE SO THAT POOLS OF WATER ARE NOT TRAPPED OR FORMED IN STORAGE YARD

BOLIVIA TO BRAZIL GAS PIPELINE (BOLIVIAN PORTION)

TYPICAL STORAGE YARD LAYOUT

 **Dames & Moore**

FIGURE 3.5

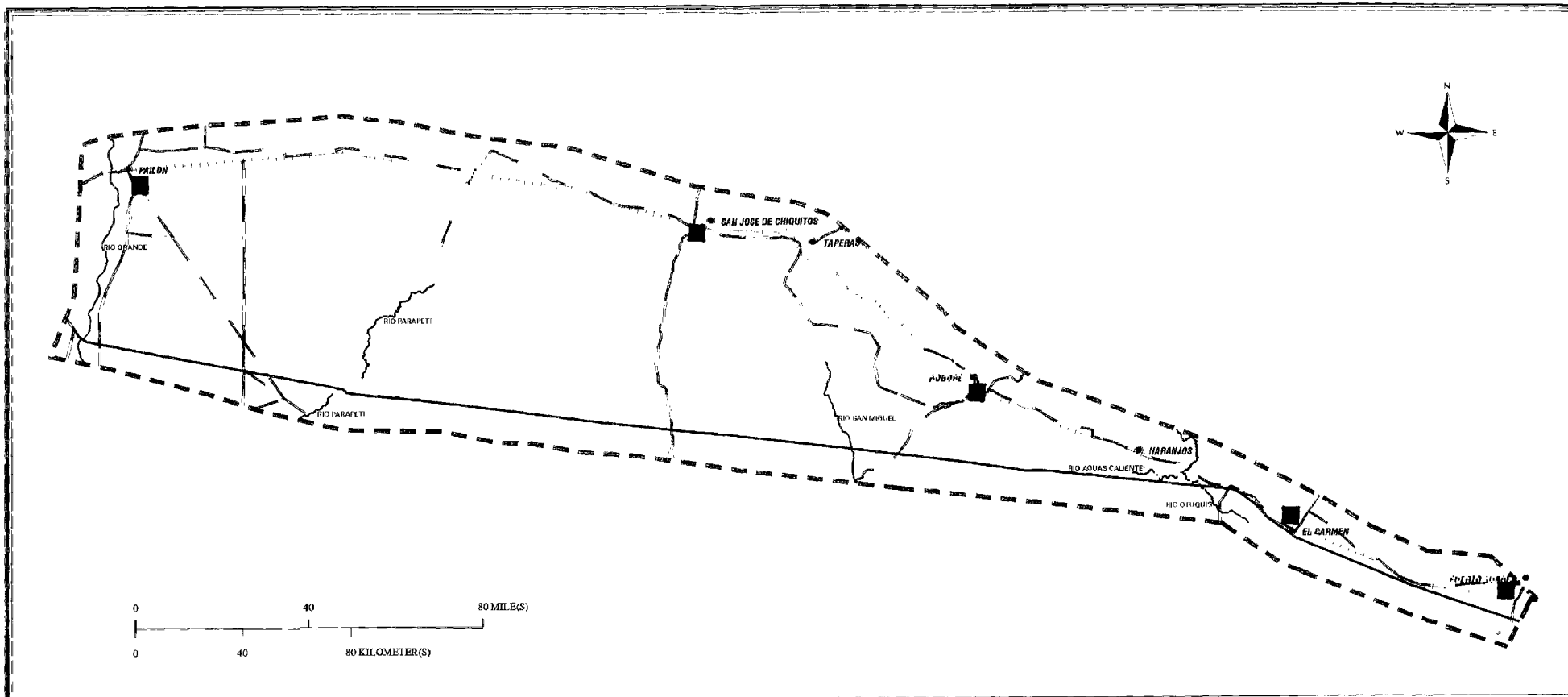

### Legend

- |   |  |
|---|--|
|  Major Roads |  Rivers        |
|  Railroad    |  Gas Pipeline  |
|  Study Area  |  Major Towns   |
|   |  Storage Areas |

### Bolivia to Brazil Gas Pipeline (Bolivian Portion)

Location of Storage  
Areas

Spread 1 & 2

Figure 3.6



DAMES & MOORE

30 M. WIDE RIGHT OF WAY

BOLIVIA TO BRAZIL GAS PIPELINE (BOLIVIAN PORTION)

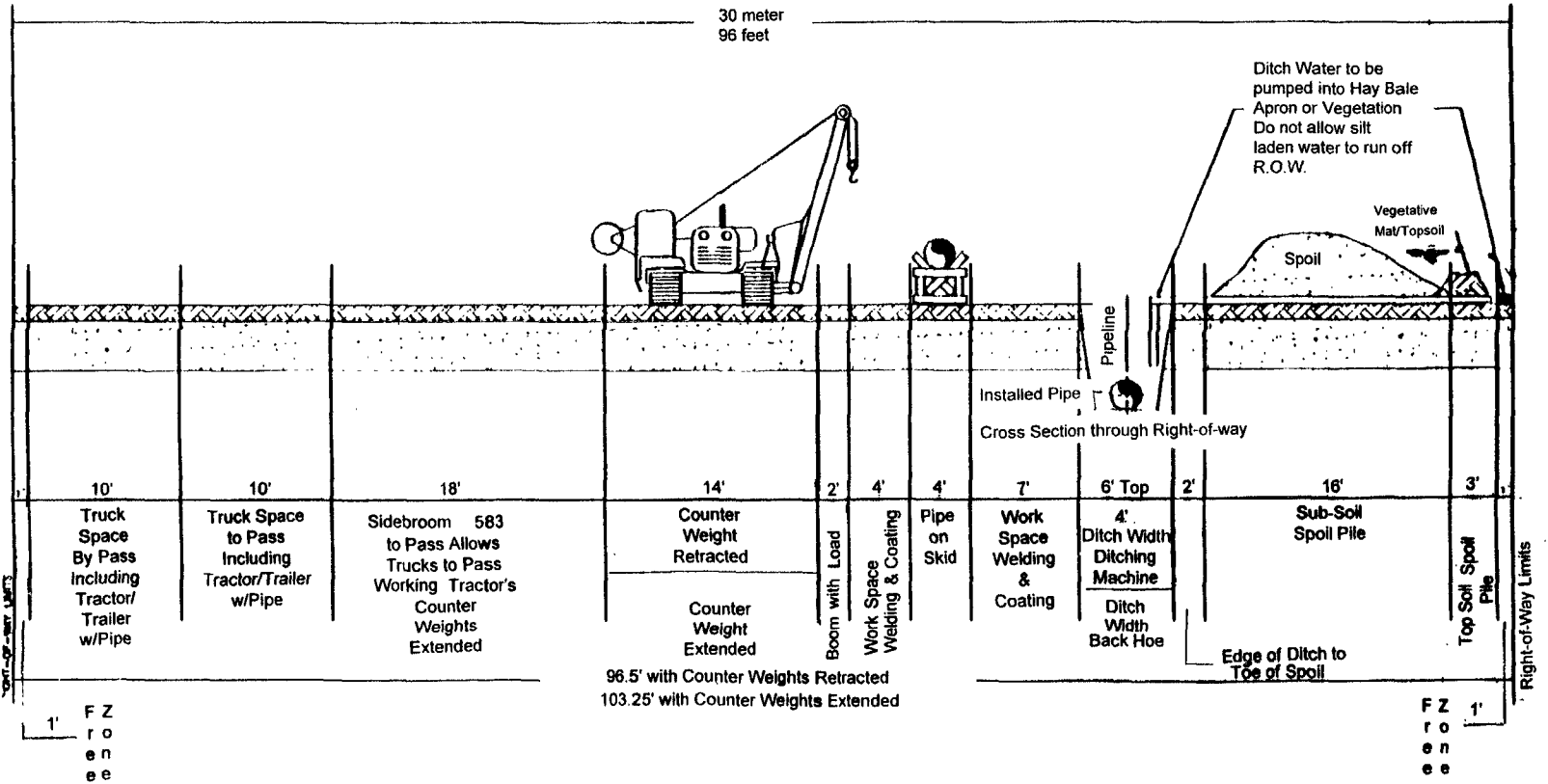

FIGURE 3.7

**CHAPTER 4.0**  
**ENVIRONMENTAL BASELINE CONDITIONS**

**TABLE OF CONTENTS**

4.1	AREA OF INFLUENCE . . . . .	4 - 1
4.2	LIFE ZONES . . . . .	4 - 1
4.2.1	Temperate Thorny Scrub . . . . .	4 - 2
4.2.2	Temperate Dry Forest . . . . .	4 - 2
4.2.3	Temperate Humid Forest . . . . .	4 - 3
4.3	PHYSICAL ENVIRONMENT . . . . .	4 - 3
4.3.1	Climate . . . . .	4 - 3
4.3.2	Hydrology . . . . .	4 - 4
4.3.3	Geology, Geomorphology and Soils . . . . .	4 - 7
4.3.4	Land Use Capacity and Current Land Use . . . . .	4 - 16
4.3.5	Planned Land Use . . . . .	4 - 20
4.3.6	Noise . . . . .	4 - 22
4.4	BIOLOGICAL ENVIRONMENT . . . . .	4 - 22
4.4.1	Vegetation . . . . .	4 - 22
4.4.1.1	Temperate Thorny Scrub . . . . .	4 - 23
4.4.1.2	Temperate Dry Forest . . . . .	4 - 25
4.4.1.3	Temperate Humid Forest . . . . .	4 - 29
4.4.2	Fauna . . . . .	4 - 29
4.4.2.1	Temperate Thorny Scrub . . . . .	4 - 30
4.4.2.2	Temperate Dry Forest . . . . .	4 - 31
4.4.2.3	Temperate Humid Forest . . . . .	4 - 34
4.5	ENVIRONMENTAL SENSITIVITY . . . . .	4 - 34

**CHAPTER 4.0**  
**ENVIRONMENTAL BASELINE CONDITIONS**

**LIST OF TABLES**

<b><u>TABLE NO.</u></b>	<b><u>DESCRIPTION</u></b>
4.1	HYDROLOGIC CHARACTERISTICS FOR RIVERINE SYSTEMS IN THE STUDY AREA.
4.2	LIST OF ENDEMIC, ENDANGERED, AND ECONOMICALLY IMPORTANT PLANT AND ANIMAL SPECIES IN THE STUDY AREA.

**CHAPTER 4.0**  
**ENVIRONMENTAL BASELINE CONDITIONS**

**LIST OF FIGURES**

<b><u>FIGURE NO.</u></b>	<b><u>DESCRIPTION</u></b>
4.1	AREA OF INFLUENCE
4.2	CLIMATE
4.3	BASINS
4.4	PHYSIOGRAPHIC PROVINCES
4.5	GEOLOGY
4.6	CROSS-SECTION RIO GRANDE
4.7	CROSS-SECTION RIO PARAPETI
4.8	STRATIGRAPHIC CROSS-SECTION IN SANTA CRUZ
4.9	STRATIGRAPHIC CROSS-SECTION IN ROBORE
4.10	STRUCTURAL CROSS-SECTION LLANURA
4.11	PHYSIOGRAPHY AND SOILS
4.12	SEISMICITY
4.13	LAND USE CAPACITY
4.14	PLANNED LAND USE
4.15	VEGETATION
4.16a-d	PHYTOTOPOGRAPHIC PROFILES
4.17	FORESTRY POTENTIAL
4.18	SENSITIVITY

## 4.0 ENVIRONMENTAL BASELINE CONDITIONS

### 4.1 AREA OF INFLUENCE

The economic effects caused by the additional income for gas sales to Brazil will likely reach the national level in Bolivia. For this study, the area of influence, or study area of the project was defined as the area included within imaginary lines located 10 km to the north of Santa Cruz to Puerto Suárez railroad and 10 km to the south of the proposed pipeline alignment (Figure 4.1). The study area incorporates both the proposed pipeline route and the main route alternative considered for the project, parallel to the railroad. The railroad corridor will also provide the main route for the transport of supplies for the project and is thus considered part of the project area.

The study area is largely unpopulated and physiographically homogeneous, dominated by an almost flat topography. The Sierras Chiquitanas enter into the northern and eastern portions of the study area. Much of the study area is dominated by undisturbed vegetation, mainly dry forests and herbaceous and shrubby floodplains. The Gran Chaco National Park is located in the west-central portion of the study area and was instituted to protect the dry forest ecosystem of the Chaco. Land uses are restricted to relatively small areas of agricultural production, most of which are concentrated in the western portion of the study area.

A description of the physical and ecological conditions encountered along the pipeline route and within the study area is provided in the following sections. A discussion of cultural and socioeconomic conditions related to the project is included in Chapter 5 of this report.

### 4.2 LIFE ZONES

In Latin America, the Holdridge system of ecological classification is widely used to provide a description of the overall environmental conditions in an affected area based on "life zones". These "life zones" are areas characterized by specific combinations of temperature, annual precipitation, and potential evapotranspiration. Conceptually, equivalent combinations of these parameters result in similar ecological areas.

Three life zones occur within the study area: Temperate Thorny Scrub, Temperate Dry Forest, and Temperate Humid Forest (Figure 4.1). These life zones are described in detail in the following sections.

#### **4.2.1 Temperate Thorny Scrub**

This life zone is located in the dry region of the Chaco between the Río Grande and the Bañados de Izozog in the southwestern portion of the study area. It includes sedimentary plains at an average elevation of 300 meters above sea level (masl), with average annual precipitation from 450 to 550 mm and biotemperatures between 12° and 24°C. This area experiences frosts and low temperatures during the winter months. The highest temperatures occur from October to January.

Physiographically, this area consists of a broad flat plain which slopes steeply in areas ranging from 180 to 350 masl. Sand dunes occur at relatively regular intervals and the soils have a very low capacity for water retention.

#### **4.2.2 Temperate Dry Forest**

Most of the study area is within the Temperate Dry Forest life zone. The portion of the pipeline project falling within this life zone occurs approximately between Isla Verde and El Carmen. The Temperate Dry Forest in this area is characterized by a subtropical bioclimate with low temperatures and occasional frosts during the coldest part of the year. The biotemperatures range from 12° to 24°C. The dry season lasts July through November with August to October being the driest months. However, rainfall is relatively evenly distributed throughout the year.

Geomorphologically, the area consists of plains underlaid by sediments of alluvial origin with the exception of areas in the north and the east which include mountainous terrain with altitudes ranging from 400 to 700 masl. The soils in this area are sandy and very permeable.



### 4.2.3 Temperate Humid Forest

This life zone includes the northeast portion of the study area east of Roboré. It is characterized by a humid, warm bioclimate with an average temperature of 23.5°C and annual precipitation ranging from 900 to 1150 mm.

The predominant land forms in the area are plains underlaid by alluvial sediments and undulating or rolling plateaus and mountainous basal complexes associated with the Brazilian shield. The soil characteristics vary depending on physiographic location. They range from very low to high permeability soils and from moderate to very deep soils.

## 4.3 PHYSICAL ENVIRONMENT

The main characteristics of the physical environment within the study area are described in this section. For the description, the physical environment has been divided into climate and air quality; geology, geomorphology, and soils, including land uses; and water resources.

### 4.3.1 Climate

The entire area of influence of the project is within the Steppe Climate zone according to the Köppen classification system (Montes de Oca 1989). In general, this climate is characterized by warm dry winters, with mean temperatures over 23°C. However, southern cold fronts with temperatures dropping to 2°C occur in the winter.

In the study area, average annual temperature shows a very slight increase from west to east, ranging from 24 to 26°C throughout the study area. The distribution of average rainfall follows a similar pattern, varying from about 700 mm/yr in the southwestern portion of the study area to more than 1000 mm/yr in the east (Figure 4.2).

### 4.3.2 Hydrology

Baseline hydrologic conditions for the study area have been established from document research and field reconnaissance. The information presented in this section has been compiled from the following sources:

- IGM-based topographic mapping (scale 1:250,000)
- Gas Pipeline to Brazil EIS (CUMAT 1990)
- Bolivia-Brazil Pipeline Project Field Trip Report - Aug. 5-25, 1995 (Beasley et al.)
- 1996 Report for Bolivia Logistics Requirement and December 1995 Trip (YPFB, Petrobras, Enron, BTB)

The study area lies on the drainage divide between the Amazon basin to the north and the Paraguay basin to the south. The proposed pipeline route lies within the Llanura Chaqueña, which is generally very flat with very little relief, except where the plain is cut by occasional small streams and creeks. Significant rivers which cut the Llanura Chaqueña include the Río Grande and the Río Parapetí, which drain the western portion of the region and flow northward to the Amazon Basin; the southward flowing Río San Miguel, which drains the central portion of the region; and the eastward flowing Ríos San Rafael/Aguas Calientes, Tucavaca, and Otuquis, which drain the Sierras Chiquitanas in the eastern portion of the region, draining south and east to the Río Paraguay.

Rivers, streams, and creeks in the Llanura Chaqueña generally lack well-defined channels, and are often characterized by broad meandering floodplains, frequent bank erosion and channel shifts during periods of high flows. Large areas of the Llanura Chaqueña are subject to periodic flooding.

The proposed pipeline route includes four main river systems: the Río Grande, the Río Parapetí, the Río San Miguel, and the Río Otuquis (Figure 4.3). The proposed route also traverses three large wetland regions: 1) the Bañados de Izozog, associated with the Río Parapetí; 2) the Bañados de Otuquis, associated with the Río Otuquis; and 3) the Cañón de la Victoria, an intermittent connection between two distinct wetland systems, the Bañados de Otuquis in Bolivia and the

Pantanal system in Brazil. The hydrologic character of each of these features is discussed below, in order from west to east along the proposed route.

**Río Grande.** The Río Grande flows north-northeast within the Amazon watershed. At the crossing, the floodway of the Río Grande varies seasonably from 800 to 1500 m. The river bed itself is relatively shallow, 1.0 to 1.5 m deep, and may have one or more water courses measuring 20 to 30 m in width. The river meanders significantly and is known to shift its bed alignment with some frequency within the floodplain, with no evidence of significant scour in the channel bed.

Average monthly flow measurements from the nearest gaging station, located 122 km upstream of the proposed crossing, ranged from 42.5 cms (cubic meters per second) in September to 11061.1 cms in February (CUMAT 1990). Flow is typically shallow, rapid and smooth, although wind effects may cause surface turbulence. As indicated in Table 4-1, significant sediment transport has been observed in the Río Grande. Current uses in the study area are limited to irrigation.

**Río Parapetí.** The Río Parapetí flows north-northeast within the Amazon watershed, disappearing into the excessively drained sands north of the Bañados de Izozog, and reappearing sporadically a few kilometers to the north. The proposed pipeline will intersect this system between pipeline kilometer post (KP) 99+00 and 195+00. In the area where the right-of-way crosses the Bañados de Izozog, the Río Parapetí floodplain encompasses roughly 30 kilometers of the Bañados de Izozog with its main watercourse roughly 20 meters wide and 1 to 3 meters deep.

This section of the Parapetí is relatively unimpacted, although upstream sections have been channelized and diked for irrigation. Downstream of the crossing, the Parapetí passes through excessively drained soils, in which it disappears intermittently. The Bañados de Izozog, encompassing approximately 6,330 km<sup>2</sup>, lies to the east of the Parapetí at this location. The plains are inundated for most of the year, with the driest conditions occurring in August through October.

Average monthly flow measurements for the Parapetí have been estimated for the gaging station at San Antonio, located 285 km upstream of the proposed crossing (CUMAT 1990). Values range

from 12.2 cms in September to 157 cms in February. Flows in the channel are typically shallow, rapid and smooth. There is no evidence of erosion problems within the study area.

**Río San Miguel.** The Río San Miguel flows southward within the Río de la Plata watershed, originating in the Cantaros Mountains. The system follows a well defined course through the Chaco plains, but becomes wide and shallow in the vicinity of the crossing near Fortín Suárez Arana. The proposed pipeline will affect this system between KP 294+00 and KP 298+00. The contributing drainage area to this point is approximately 1,978 km<sup>2</sup>. At the crossing, the floodway of the Río San Miguel is approximately 150 meters wide. The river bed itself is characteristically 10 meters wide and only 0.5 to 1.0 meters deep. The river is rather pristine in this region. However, extensive cattle ranching land uses occur in this area.

Average monthly flow measurements from the nearest gaging station, located 35 km downstream of the proposed crossing, range from 0.43 cms in July to 2.76 cms in March (CUMAT 1990). Typical flows are smooth, slow, and very shallow. Channel erosion is not evident; however, wind erosion of the adjacent dunes has been identified as an item of concern.

**Río Otuquis.** The Río Otuquis flows eastward and southward, formed from the combined flows of the Ríos Tucavaca and Aguas Calientes and terminating in the Bañados de Otuquis, which drains eventually to the Paraguay River. The proposed pipeline will affect this system between KP 423+00 and KP 427+00. The contributing drainage area to this point is approximately 14,700 km<sup>2</sup>. To the north and south of the crossing, there are lowlands which experience flooding during very wet years. The river bed is well defined in this region, with sloped banks, a typical top width of 25 meters, and a typical flow depth of approximately two meters. This system has not been impacted and has no defined uses in the right-of-way. The river course is stable but is known to flood during wet years.

Average monthly flow measurements for the Río Otuquis, estimated at the confluence of the Ríos Aguas Calientes and Tucavaca, 10 kilometers upstream of the proposed crossing, range from 1.55 cms in September to 33.9 cms in March (CUMAT 1990). Flow is rapid and smooth with some meander, causing moderate erosion of the side banks.

**Río Aguas Calientes.** Although not directly within the proposed right-of-way of the pipeline, the Río Aguas Calientes is included in the baseline hydrologic description because of the proximity of this nearly pristine system to the proposed pipeline corridor, requiring consideration of impacts related to the construction and operation of the pipeline. The Río Aguas Calientes, fed by hot springs to the north is located just 1-2 km north of the proposed alignment, between KP 395+00 and KP 400+00. The Río Aguas Calientes flows eastward, joining with the Río Tucavaca and flowing southward into the Río Otuquis.

Documented average annual monthly flows range from 1.11 cms in October to 13.77 cms in March (CUMAT 1990). The system has not been significantly impacted by man.

**Cañón de la Victoria.** The Cañón de la Victoria is the last hydrologic feature to be encountered by the pipeline alignment in the vicinity of stations 525+00 to 530+00. The Cañón de la Victoria represents a sensitive and unique connection between two very different hydrologic and biologic systems, the Bañados de Otuquis of Bolivia and the Pantanal of Brazil.

The hydrologic connection between these two systems is intermittent, with the direction of exchange dependent upon the relative water elevations driving each system. The hydrologic connection at Cañón de la Victoria is essentially unimpacted within the study area, with the exception of the railroad right-of-way and an adjacent transportation corridor which are located south of its narrowest point. In order to minimize further impacts to this unique hydrologic feature, the proposed pipeline alignment will run south of the existing corridor of the railroad.

### 4.3.3 Geology, Geomorphology and Soils

**Physiographic Setting.** Bolivia is divided on the basis of geologic and geomorphic characteristics into seven physiographic provinces (Pareja et al. 1978; Clapperton 1993) which form a series of subparallel, north-south to northwest-southeast trending belts. From west to east, these include the following physiographic provinces (Figure 4.4):

- Cordillera Occidental (Western Cordillera);
- Altiplano (High Plateau);
- Faja Subandina (Andean Foothills Ranges);
- Llanura (Plains);
- Sierras Chiquitanas (Chiquitana Ranges); and,
- Escudo Brasileiro (Brazilian Shield).

The proposed pipeline route lies entirely within the Llanura physiographic province. This region consists of a broad flat plain of very low relief, varying in width from about 200 to 700 km, which extends from the Sub Andean foothills on the west to the Bolivian/Brazilian border on the east. The Llanura is underlaid by a nearly continuous blanket of quaternary alluvial, lacustrine, eolian and colluvial deposits, consisting of clay, silt, sand, and gravels (Pareja et al. 1978). These materials are underlaid at depth by complexly folded and faulted bedrock of Paleozoic to Tertiary age, similar to units which are exposed in the Faja Subandina and the Cordillera Occidental, as well as to some units which are exposed in the Sierras Chiquitanas and the Brazilian Shield. (Figure 4.5).

The most significant surface features in the project area are several broad depressions known as *bañados* (flood-prone areas). These are broad, low-lying areas with internal drainage systems which fluctuate greatly in extent depending on the variations in annual precipitation. They include *Bañados de Izozog*, in the western portion of the area, into which the *Río Parapetí* flows, and which drains intermittently to the north; *Bañados de Otuquis* or *Tucavaca* in the east, which lie along the western banks of the *Río Paraguay*; and several similar systems to the south of the study area which are fed by the *Río San Miguel* and several smaller southward flowing streams in the central portion of the study area.

The generally flat topographic surface of the Llanura Chaqueña is also broken in a few places by the appearance of narrow and elongated, east-west to northeast-southwest trending bedrock ranges, such as the Sierras Chiquitanas and a series of unnamed hills in the central portion of the study area. These consist of folded and faulted bedrock of Paleozoic, Mesozoic, and Tertiary ages.

**Geologic Setting.** The Llanura physiographic province is a broad, northwest-southeast trending trough which is bounded on the northeast and southwest by relatively elevated portions of the Brazilian Shield and the Faja Subandina, respectively. The surface of the Llanura is characterized by a nearly complete cover of quaternary aged sediments. These consist of varying thicknesses of generally fine grained sediments (clay, silt, and fine sand with lesser amounts of medium to coarse sand and gravel), which were deposited by alluvial, fluvio-lacustrine, coluvial and eolian processes. These may contain significant amounts of organic material in some areas. Also present are a few salt deposits of minor extent in the southern portion of the study area, as well as thin layers of volcanic ash in some areas (Pareja et al. 1978). These materials have not been studied or described in detail.

Available information indicates that the quaternary surficial deposits of the Llanura Chaqueña generally range in thickness from a few meters to as much as 25-35 meters (Villanueva 1996). The thickness of unconsolidated materials can be expected to be greatest near major river and stream channels.

**Geotechnical Studies of River Crossings.** Information concerning the depths and characteristics of soils in the channels of the Río Grande and Río Parapetí at the proposed gas pipeline crossing points was obtained from geotechnical studies provided by YPFB (Sadad, undated *a* and *b*; YPFB 1994).

*Río Grande Crossing.* Based on data in Sadad (undated, *a*) and YPFB (1994), a geologic/geotechnical cross section of the river channel was constructed (Figure 4.6). The subsurface materials present in the river channel consist of interlayered brown, reddish brown, gray, yellowish, whitish and orange clay, silt, and sand with minor amounts of fine gravel from the surface to depths of about 35-40 meters. Beds vary in thickness from less than one meter to a maximum of about 6.6 meters. Secondary calcium carbonate cementation was noted in some places.

Bedrock of possible Tertiary age may be present below a depth of about 35-40 meters, consisting of interbedded reddish to whitish, brown and gray sandstone and claystone, containing some fine gravel-sized fragments of chert, quartzite and granite. Secondary

calcium carbonate cementation and concretions of gypsum were noted in this material in some places.

*Río Parapetí Crossing.* Based on the reports cited above, the subsurface materials present in the river channel consist of interlayered yellowish, yellowish brown, brown, greenish brown and gray silty clay, silty sand, clayey sand, sandy and clayey silt, from the surface to the total depths drilled of about 10-10.5 meters (Figure 4.7). Beds vary in thickness from less than one meter to a maximum of about 3.8 m. These materials demonstrate extreme hardness in some cases, possibly due to the presence of secondary calcium carbonate cementation.

The ages of the sedimentary units encountered in the area of the proposed Río Parapetí pipeline crossing are not established on the basis of the drilling and sampling performed. However, bedrock of possible Tertiary age may be present at depths of about 5-10 meters at some locations.

**Bedrock Units.** Available information indicates that the stratigraphic column in the study area includes bedrock units ranging in age from Precambrian to Tertiary (Pareja et al. 1978; YPFB, undated; Figures 4.8, 4.9, and 4.10). The stratigraphy of Precambrian to Tertiary aged bedrock units in the study area is briefly summarized in the following sections.

*Precambrian.* Bedrock of Precambrian age is exposed over a broad area in the Brazilian Shield physiographic province, to the north and east of the study area. Outcrops of Precambrian aged rocks are also described in the southern portion of the Cordillera Oriental, and deep exploratory drillholes have penetrated rocks of Precambrian age in the Altiplano (Pareja et al. 1978).

*Cambrian.* Cambrian aged rocks in the study area are exposed primarily in the Sierras Chiquitanas along the southwestern edge of the Brazilian Shield, to the north of the proposed pipeline route, where they form a prominent east/southeast-west/northwest trending range. Smaller, isolated outliers of Cambrian aged rock are also present in the Yacuses-Mutún-Puerto Suárez area in the eastern portion of the study area.



*Ordovician.* Intensely folded and faulted rocks of Ordovician age are extensively exposed over large areas of the Cordillera Oriental, Altiplano, and Faja Subandina physiographic provinces in the elevated highland areas to the west of the study area. Within the study area; however, exposed Ordovician aged bedrock units are limited to a narrow east-southeast/west-northwest trending belt on the northern side of the Sierra de Santiago, a few miles north of Roboré.

*Silurian.* Silurian aged rocks are exposed similarly to rocks of Ordovician age mentioned above in intensely folded and faulted belts extending over large areas of the Cordillera Oriental, Altiplano, and Faja Subandina physiographic provinces in the elevated highland areas to the west of the study area.

Bedrock of Silurian age, consisting of dark gray shale of the Kurusillas Formation, has also been encountered at depth in drilling for petroleum exploration purposes beneath the central portion of the Llanura Chaqueña (Pareja 1978; YPFB, undated). Within the study area, exposed rocks of Silurian age are limited to a narrow belt of rose colored sandstones which outcrop in a narrow east-southeast/west-northwest trending belt in the area of San José de Chiquitos-Quimone.

*Devonian.* Folded and faulted rocks of Ordovician age are extensively exposed over large areas of the Cordillera Oriental, and to a lesser extent in the Altiplano and Faja Subandina physiographic provinces. Devonian aged bedrock units which are exposed in the Cordillera Oriental and the Faja Subandina have also been recognized in petroleum exploration boreholes in the western portion of the study area.

Within the study area, surface exposures of Devonian aged bedrock units are limited to an east-southeast/west-northwest trending belt which makes up the southern side of the Sierra de Santiago in the Roboré-Santiago area, and a series of isolated outliers extending further to the southeast in the area of El Carmen. Some additional outliers of Devonian rocks are present in the south central part of the study region, in the area southeast of Tucavaca. Bedrock of these units has also been encountered at depth in exploratory drilling for petroleum beneath the eastern portion of the study area (YPFB, undated).

*Carboniferous.* Bedrock units of the Carboniferous system are widespread in the subsurface within the Llanura Chaqueña (Pareja 1978; YPFB, undated). Similar bedrock units are also widespread in the Faja Subandina, Cordillera Oriental and Altiplano to the west of the study area. These units are distributed broadly over the Llanura Chaqueña in the subsurface, but are generally not exposed at the surface. Only limited surface exposures of these materials are present, mainly in isolated hills in the south central portion of the study region, and in the area surrounding the Salinas de Santiago.

*Cretaceous.* Bedrock units of the Cretaceous system are exposed in a broad area of the Sierras Chiquitanas, lying to the northwest of Roboré, as well as in the area to the south of Tucavaca in the south central portion of the study region. Cretaceous rocks are also widespread in the subsurface within the Llanura Chaqueña, as has been demonstrated by numerous exploratory boreholes and seismic studies (Pareja 1978; YPFB, undated).

The lower contact of the Cretaceous rocks of the study region with the underlying older rocks is generally considered to be discordant and transgressive. Bedrock of Cretaceous age in the Llanura Chaqueña consists primarily of sandstones of the El Portón Formation, which discordantly overlie the Devonian aged Limoncito Formation in the Sierras Chiquitanas and is interbedded with conglomerates of the Tertiary aged Tobité Formation (see below).

*Tertiary.* In the study area, the transition from Cretaceous to Tertiary units is generally gradual. Tertiary rocks are widespread in the study area, and represent a widespread episode of primarily continental deposition.

**Structural Geology.** Little detailed information is available concerning the structural geology of bedrock units underlying the Llanura Chaqueña in the study area. YPFB (undated) indicate the presence of structures similar to the north-south trending folds and faults of the Faja Subandina and the Cordillera Oriental in rocks of Silurian and Devonian age lying beneath the undisturbed cover of Quaternary sediments. YPFB (undated) also referred to the presence of a series of broad arches, including the Izozog and Pilcomayo arches, which were active since the Silurian and achieved their greatest periods of uplift during the Cretaceous and Tertiary (Figure 4.10).

These features are not expressed in the Quaternary sedimentary cover which blankets the older rocks in the study area. A few folds and thrust faults with northwest-southeast and eastwest trends are exposed in the Ordovician to Cretaceous aged bedrock units of the Sierras Chiquitanas in the area north of Roboré. A series of northeast trending folds and thrust faults are exposed in the Cambrian and Ordovician aged strata in the Mutún district in the eastern portion of the study area.

A series of normal faults with northeast-southwest, northwest-southeast and roughly eastwest trends are mapped in the area of Quaternary sediments southeast of Roboré, and cutting the Cretaceous rocks in the area south of Tucavaca. These faults are inferred on the basis of seismic studies, and are not visible at the surface (Villanueva 1996).

**Geomorphology.** Published geomorphic and geologic studies indicate that the Pantanal, the region of low lying wetlands and rivers which occupies the northern portion of the Río Paraguay drainage basin, is a tectonic trough which has subsided throughout the Quaternary along deep seated faults in the underlying Precambrian basement (Clapperton 1993). The available information appears to indicate that the Bañados de Izozog have been formed by a similar mechanism. As discussed above, exploratory drilling and geophysical studies have demonstrated the presence of deep seated faults in the Precambrian basement underlying the Llanura Chaqueña. These features appear to parallel those responsible for the formation of the Pantanal to the east, and may have had a similar history of development. The Sierras Chiquitanas in the east central portion of the study area appear to represent a relatively uplifted block relative to the subsiding Pantanal to the east and the Bañados de Izozog to the west.

The boundary of the Pantanal is fairly well defined in the northern and western portions of the Río Paraguay drainage basin, where it is marked by a fairly prominent fault line escarpment, the Serra de São Jeronimo. Elsewhere; however, the boundaries of the subsiding basins are indistinct.

Surficial materials in the western portion of the study area are apparently derived from a series of coalescing alluvial fans which have spread outward from the Faja Subandina in Quaternary time. In the eastern portion of the study area a similar pattern exists, where alluvial fans derived from the Sierras Chiquitanas merge with similar fans derived from the area of the Brazilian Shield further to the east. The presence of meandering river systems throughout the region through most

of Quaternary time is demonstrated by sedimentation and deposition patterns which are clearly visible on aerial photographs, and which were observed during aerial reconnaissance of the study area.

Recent subsidence is well documented in the area of the Pantanal by the presence of more than 300 meters of Quaternary sediments in the basin, of which more than 200 meters lie below the present sea level (Tricart 1982, in Clapperton 1993). The maintenance of gentle surface slopes within the region, despite the large volumes of sediment being deposited, is believed to result from the constant rate of subsidence (Clapperton 1993).

**Soils.** Soils present in the study area are classified into four major groups as follows (Figure 4.11):

- Alluvial and eolian plains soils, which occur mainly in the western third of the project area, and include soils developed on ancient to recent alluvial deposits, eolian deposits and marshy areas (bañados). Soil types present in this group include mainly fine grained materials (clays and silts), with occasional medium to coarse grained materials (sands and gravels), especially on or near modern floodplains. Organic content of most of these soils is relatively low, and in some areas they may contain elevated levels of salts or alkaline deposits. Soil fertility ranges from poor to good.
- Soils developed directly on exposed sedimentary bedrock units of Cretaceous to Carboniferous age, which occur mainly in the central portion of the study area. These soils may include materials ranging from fine to coarse grained, depending on the nature of the underlying parent material. On and near the floodplains of the Ríos Parapetí, San Miguel, and San Rafael these soils may be overlain by a layer of recent alluvial deposits. They may contain saline deposits in some areas, especially in the Río Parapetí/Bañados de Izozog area. Fertility of these soil units is generally poor.
- Mountain soils, present mainly in the area of the Sierras Chiquitanas and in isolated hilly areas, most of which are concentrated in the eastern portion of the study area. These soils

are generally shallow sandy soils that occur in areas of inclined strata and relatively steep slopes, and are generally characterized by low fertility.

- Soils developed on crystalline Precambrian aged rocks of the Escudo Chiquitano (exposed Precambrian basement rocks along the Bolivian/Brazilian border). These units are present only in a limited area in the easternmost portion of the project area, immediately north and west of Puerto Suárez. They occur on steep slopes, hilltops and valleys and vary in depth according to topography. Fertility of these soil units is generally characterized as low, and in some areas they contain elevated concentrations of aluminum and alkali salts, which may be toxic in some cases.

**Regional Seismicity.** Dames & Moore requested a chronological search of the National Oceanic and Atmospheric Administration (NOAA) National Geophysical Data Center's Earthquake Data File for the study area (Figure 4.12). The coordinates for the search area were 12° - 22° south latitude; 52° - 68° west longitude.

As shown by the epicentral map (Figure 4.12), the western portion of the study area is characterized by an elevated level of historical seismicity, while the eastern portion has been relatively less active. The data indicate a high level of ongoing seismic activity in the Faja Subandina and the Cordillera Occidental, decreasing dramatically in the area of the Llanura Chaqueña. The area of the Brazilian Shield to the east has been characterized by a very low level of seismic activity during the period of record. Reportedly, the seismic record for the Llanura Chaqueña indicates the presence of earthquake focal sources which are very deep (> 250 km) (Whiteside 1996). No near surface seismic activity is reported for the region.

Review of the available information relative to historical earthquake intensities in the study area (Ceresis 1983) indicates that the maximum intensities experienced in the study area during the period of historical record have been as follows (Figure 4.12):

- In the western portion of the study area (west of about 62° West Longitude), the maximum historical intensities range from V to VI on the Modified Mercalli (MM) Intensity Scale.

- In the eastern portion of the study area (east of about 62° West Longitude), the maximum historical intensities have been less than V (MM).

#### 4.3.4 Land Use Capacity and Current Land Use

Land use capacity is determined by physical characteristics such as slope, soil conditions, precipitation, and hydrology. Within the study area, low precipitation and relatively poor soils limit the capacity of the land to sustain intensive cattle ranching or agricultural activities. The Land Use Capacity Map developed by Regional Development Corporation of Santa Cruz (Corporación Regional de Desarrollo de Santa Cruz, Cordecruz) utilizes a land use capacity classification with eight categories (Cordecruz-KFW 1995), in which Class I represents lands that can sustain intensive agricultural uses and Class VIII groups lands that because of extreme limitations are not able to sustain active uses and are thus left for protection. Based on the Cordecruz map, the following land use capacity categories are found in the study area (Figure 4.13):

- *Class II.* Includes areas that can be used for agricultural and livestock production, but present slight limitations such as the need for irrigation. This land use capacity category occupies only a small portion of the study area and is limited to small areas between the Río Grande and Río Parapetí.
- *Class III.* Areas that may be utilized for agriculture or livestock but that face severe drainage limitations and require the application of intensive technologies to sustain the activity. This land use capacity class occurs over most of the western half of the study area. The main limitation in this area is the lack of water.
- *Class IV.* Areas that may be utilized for agricultural and livestock uses but face severe drainage, erosion and fertility limitations. Class IV is represented by disjunct areas mainly on the southern portion of the study area, along the proposed pipeline alignment.

- *Class V.* Areas useable for cattle ranching and permanent crops with drainage limitations. These areas occur along the southwestern portion of the study area, and dominate the central portion of the study area.
- *Class VI.* Areas useable for cattle ranching and permanent crops, with erosion or erosion/fertility limitations. This class covers much of the area between San José de Chiquitos and Naranjos.
- *Class VII.* Areas that may sustain cattle ranching and permanent crops but face severe very severe in drainage, erosion, and/or fertility. This class occurs west of San José de Chiquitos.

Information concerning current land cover and land use in the study area was obtained primarily from review of the "Mapa de Cobertura y Uso Actual del Suelo, Bolivia" (Map of Coverage and Current Soil Usage, Bolivia; GEOBOL, 1978). In general, current land uses respond to the land capacity classes found in the study area. A total of 12 Land Cover/Land Use Types are indicated to be present in the study area, most of which represent undisturbed areas, as follows:

#### **Lowland Forests (Bosques en Tierras Bajas)**

- *Deciduous Forest (Bosque Deciduo).* This is the most prevalent land use type within the study area. In the western portion of the study area, this land cover type is present on the west bank of the Río Grande, and also covers most of the area between the Río Grande and the Río Parapetí. It includes much of the area of the Bañados de Izozog. In the central and eastern portions of the study area, the Deciduous Forest is also widespread, but is more intermixed with other land use types, principally. Areas characterized as Deciduous Forest have not been developed for pasture or other types of agriculture. The lack of surface water and the presence of a very deep water table, which limit the potential for the development of irrigation systems, and poor quality of soils appear to be the primary factors limiting the development of this land use type for stock grazing or other types of agriculture. This land cover type has been developed only to a little extent by the logging

industry, apparently due also to the lack of moisture, which limits the development of commercially valuable timber resources.

### **Lowland Pasture and/or Shrubland (Pastos y/o Arbustos en Tierras Bajas)**

- *Dry Pasture and/or Shrubland (Pastos y/o Arbustos en Ambiente Seco)*. This is the second most prevalent land use type within the study area, especially in its central portion. The distribution of dry pasture and/or shrubland appears to be dependent on subtle variations in topography, as well as variability in soil types, availability of surface water and depth to groundwater. The use of this land appears to be restricted to low density grazing, possibly on a seasonal basis depending on rainfall.
- *Humid Pasture and/or Shrubland (Pastos y/o Arbustos en Ambiente Húmedo)*. This land cover type occurs only in the area of the Bañados de Otuquis or Tucavaca in the eastern portion of the study area. The deltas of the Ríos Otuquis and Tucavaca and their smaller tributaries have formed a well watered lowland region of fertile soil on the west bank of the Río Paraguay. This land may support grazing on a year round basis, and may also support some forms of irrigated agriculture.
- *Temporarily Humid Pasture and/or Shrubland (Pastos y/o Arbustos en Ambiente Temporalmente Húmedo)*. This land use type occurs in limited areas in the central portion of the study area, including the foothills of the Sierras Chiquitanas and portions of the headwaters of the Río San Miguel. The use of this land may vary depending on annual and/or seasonal variations in precipitation. Primary land use appears to be for grazing, with possibly some other forms of agricultural production on a limited basis.

### **Humid and/or Flooded Lands (Tierras Húmedas y/o Anegadas)**

- *Humid and/or Permanently Flooded Lands (Tierras Húmedas y/o Anegadas Permanentes)*. Within the study area the distribution of this land cover type is restricted to portions of the floodplain of the Río Parapetí, in the western part of the study area, and the Río Otuquis in the east. These areas are characterized by abundant surface water, as well as shallow



groundwater, and can support fairly extensive agricultural development. The principal crop produced in these areas is rice. Also reported is some production of cotton, soya, sugar cane and fruits, as well as some livestock grazing.

### **Intermediate Elevation Forests (Bosques en Tierras Intermedias)**

- *Deciduous Forest (Bosque Deciduo)*. This land use type occurs only in the westernmost portion of the study area, in the Andean Foothills to the west and southwest of Santa Cruz, primarily to the west of the Río Grande. The proposed pipeline route does not pass through any terrain classified within this land use type. Based on limited available information, the development potential of this land use type appears to be limited due to lack of moisture, steep topography and possibly poor quality of soils. Some development of timber resources may have occurred in some areas.

### **Uncultivated Low Lying Land (Eriales en Tierras Bajas)**

- *Salt Flats and Saline Lands (Salares y Tierras Salinas)*. These land use types occur only in very limited areas in the south central portion of the study area, in the area around the town of Fortín Ravelo. They appear to be small basins with internal drainage systems where salt deposits or highly saline soils have developed as a result of repeated cycles of inundation and evaporation. They do not support agricultural development, but may be used on a limited basis for mining of salt.
- *Sandy Deposits (Depósitos Arenosos)*. These land use types occur only in very limited areas in the southwest and south central portions of the study area, mainly on the floodplains of the Río Grande, Río Parapetí, and Río San Miguel. They appear to result from frequent and/or recent erosion and inundation during high flows on the rivers, followed by deposition of sand and gravel. Due to the lack of vegetation, high permeability and poor quality of the soils in these areas, as well as the threat of periodic flooding, they do not support agricultural development or other activity.

## **Bodies of Water in Low Lying Areas (Cuerpos de Agua en Tierras Bajas)**

- *Lakes (Lagunas)*. Small lakes are present on the Río Parapetí, in the northern portion of the Bañados de Izozog, and in the lower reaches of the delta of the Río Otuquis, in the far eastern portion of the study area. These small water bodies may be used for potable water supplies, irrigation and stock watering, and may also support varied populations of fish, mammals, and waterfowl.

## **Cultivated Lands (Tierras Cultivadas)**

- *Varied Cultivation and Undifferentiated Cultivated Lands, Pasture and Shrubland (Cultivos Diferenciados y Cultivos, Pastos y Arbustos Indiferenciados)*. Areas of significant cultivation occur primarily in the westernmost portion of the study area, mainly to the west of the Río Grande. Principal crops grown in this area include soybeans, sunflowers, barley, and corn.

## **Cultural Features (Rasgos Culturales)**

- *Cities and Towns (Ciudades y Pueblos)*. In general, the study area is characterized by a lack of urban areas. The city of Santa Cruz de la Sierra is located just west of the study area. Several towns are located along the railroad, such as San José de Chiquitos, Roboré, and Puerto Suárez, as well as some smaller settlements (see Chapter 5).

### **4.3.5 Planned Land Use**

Cordecruz, in association with the German Government developed the Land Use Plan (Plan de Uso de Suelo, PLUS) for the Department of Santa Cruz, which was published in 1995 (Cordecruz-KFW 1995). The plan was developed based on a GIS analysis and was intended to provide a planning document for the future development of the Department in a sustainable manner.

The PLUS proposed the following main uses within the study area (Figure 4.14):

- *Protected Areas (RIN 1 through 7).* They include the Gran Chaco National Park (RIN 1), which was instituted in 1995. The national park incorporates a buffer area (ANMI 1-3) where the managed use of resources is for the sustainable development of the local indigenous populations.

The plan proposes the establishment of the Pantanal National Park (RIN 2), which is justified by the biogeographic value of the area as the connection between the two large ecosystems of the Pantanal and the Bañados de Otuquis. RIN 6 is the proposed Biological Reserve Serranías de Santiago, Sansas and the Tucavacas Valley. This area is recommended due to its biological resources and the scenery associated with the Serranías Chiquitanas. Finally, RIN 7 is a proposed area for the protection of the road corridor to the Paraguay River. This area represents the connection between the ecosystems of the Cerrado in Brazil, the Pantanal and the Chaco.

The PLUS report discusses the Parque Nacional Santa Cruz La Vieja and indicates the mapping label PH1; however, this map unit is not shown in the PLUS map. This small park is located just south of San José de Chiquitos and includes the area where the city of Santa Cruz de la Sierra was originally founded. The access road to the pipeline right-of-way from San José de Chiquitos passes through this historical park. This area harbors historical resources and plant endemism.

- *Extensive Cattle Ranching (GE AR, GE C 4).* This planned use is assigned to much of the study area, including the central portion, east of the Gran Chaco National Park and the area between the national park and the Río Grande. East of the park (GE C 4), it includes areas with limitations for intensive cattle ranching and agricultural uses, but that may sustain extensive cattle ranching with little management. West of the park (GE AR), irrigation is possible, allowing for higher use intensity.

- *Agricultural, Livestock and Agri-Forestry Uses (AI 2, AI 3, AS 2, AS 3, AS P 3)*. Includes areas in which intensive agricultural activities are possible (AI 2), such as the alluvial plains east of the Río Grande. Areas alongside the railroad between San José de Chiquitos and Naranjos, already under agricultural and livestock uses are slated for continued agricultural uses (AS 2, 3).
- *Intensive Cattle Ranching (GI 2)*. It includes large portions of the study area between Río Otuquis and Puerto Suárez. Intensive uses are possible due to water availability, savannah vegetation, and existing access.
- *Preserved and Exploited Forests (B 3, B P 1)*. The PLUS proposes an area for sustainable forestry exploitation in the Río Otuquis region (B 3), where low soil fertility limits its potential for other uses. It also proposes to preserve the forested system associated with the Río Grande and Río Tucavacas.

#### 4.3.6 Noise

The majority of the gas pipeline alignment in Bolivia extends through undeveloped and agricultural areas with minimal or no human activities. Consequently, the noise levels along the pipeline right-of-way are, in general, associated with the natural environment and correspond to low levels of noise. The proposed storage yards and the Yacuses compressor station are to be located within or in the vicinity of urban areas. The level of noise at these locations is associated with road traffic and the operation of the Santa Cruz-Corumbá railroad system. The level of noise at these locations is considered in the low to medium range since the traffic in both the roadways and the railroad is infrequent.

### 4.4 BIOLOGICAL ENVIRONMENT

#### 4.4.1 Vegetation

Various types of vegetation cover are present throughout the study area (Figure 4.15, 4.16a-d), particularly since the area is a transition zone between the biogeographic regions of the Cerrado

and the Amazon to the north, and the Chaqueña region to the south and the Andes to the west. The main vegetation associations are described within the context of the life zones present in the study area.

#### 4.4.1.1 Temperate Thorny Scrub

The vegetation formations for this life zone are characterized by low scrub, xerophytic, and semideciduous formations dominated by underbrush and scattered emergent trees such as *Aspidosperma quebracho-blanco* (Cacha, Quebracho blanco, Apocynaceae), *Chorisia speciosa* (Toborochi, Bombacaceae), *Ziziphus mistol* (Mistol, Rhamnaceae); and columnar arboreal cacti such as *Stetsonia coryne* and *Cereus forbesii* (Caracoré). Some smaller trees (5 - 10 m) are present such as *Athyana weinmannifolia* (Sapindaceae) and *Sideroxylon obtusifolium* (Sapotaceae).

The shrub stratum is very dense, with height ranging from 3 to 6 m and is dominated by *Ruprechtia triflora* (Choroqueta, Polygonaceae) accompanied by other species such as *Pereskia sacharosa* (Cuguchi, Cactaceae), *Quiabentia planzii* (Cactaceae), *Opuntia paraguayensis*, *O. retrorsa* (Cactaceae), *Celtis chichape* (Ulmaceae), *Maytenus spinosus* (Celastraceae), *Bougainvillea praecox* (Nyctaginaceae), *Capparis salicifolia* (Sacha sandía), *C. tweddiana*, *C. speciosa* (Capparidaceae), *Mimosa detinens* (Fabaceae), *Castela coccinea* (Simaroubaceae), *Ximenia americana* (Olaceae), and other cylindrical cactaceous trees that are present in the basal part of the stratum which include *Harrisia pomanensis*, *Mombillea ebenacantha*, *M. parapetiensis* and *Cleistocactus baumani*.

The level of epiphytism is very low and is predominantly represented by *Tillandsia duratti* (Bromeliaceae) and *Ripsalis aff. tucumanensis* (Cactaceae). Vines are rare, and include *Arrabidaea corallina*, *A. truncata* and *Herreria montevidensis* (Liliaceae). The understory in some areas is covered with *Bromelia serra* (Carahuatá, Bromeliaceae). Disturbed areas, such as road sides, have nitrophyllous species of the genera *Ruellia* (Acanthaceae), *Crotón* (Euphorbiaceae), and *Sida* (Malvaceae).

There are two main vegetation types present in the Dry Chaco, associated mainly due to the texture of the soil, the local topography and differences in the water table. The variations observed include the following:

- A tall forest, with trees up to 15-20 meters tall, occurs in areas with heavy soils of clayey texture and good water retention capacity which are flooded for short periods (mainly during the rainy season). The dominant tree species include *Calycophyllum multiflorum* (Palo blanco, Rubiaceae), *Phyllostylon rhamnoides* (Cuta, Ulmaceae), *Maclura tinctoria* (Mora grande, Moraceae), *Bulnesia sarmientoi* (Guayacán, Zygophyllaceae), *Caesalpinia paraguariensis* (Algarrobillo, Guayacán, Fabaceae), *Geoffroea decorticans* (Chañar, Fabaceae). The shrub stratum has a height ranging from 3 to 6 meters and is dominated by *Tabebuia nodosa* (Bignoniaceae), *Sideroxylon obtusifolium* (Sapotaceae), *Trithrinax brasiliensis* (Saó, Arecaceae), and *Achatocarpus praecox* (Achatocarpaceae). The terrestrial bromelia, *Aechmea dystichantha*, dominates the groundcover stratum. Common vines include *Arrabidea corallina* (Bignoniaceae), and *Serjania* sp. (Sapindaceae).
- A moist forest dominated by hydrophytic species on the alluvial terraces was formed by old channels of the existing rivers and in areas where the water table is elevated. Typical species in these areas include *Prosopis chilensis*, *P. affinis*, *Geoffroea striata* (Chauchachi), *Phytocellobium scalare* (Juno, Fabaceae) and a shrub, *Vallesia glabra* (Amarguillo, Apocynaceae). Along rivers, semideciduous forests are commonly present. These forests are characterized principally by species of the genera *Prosopis* and *Phytocellobium*. *Guazuma ulmifolia* (Coco) is abundant in the Río Grande zone. The alluvial plains have pioneer communities characterized principally by *Tessaria integrifolia* (Pájarobobo, Asteraceae), *Vallesia glabra*, and in the relatively stable terraces, a community of *Salix humboldtiana* (Sauce, Salicaceae) is often present.

The forests of the Dry Chaco do not represent an important resource for timber exploitation (Figure 4.17); however, they are essential for the conservation of soils and to avoid soil erosion and to serve as a wildlife refuge. Areas adjacent to roadways in this area have been deforested in order to utilize the land for agricultural activities. Cattle ranches are also located at various points throughout the region.

On the other hand, a large number of endemic species are present in this area (Table 4.2), particularly of the family Cactaceae, which are characteristic of arid regions. These species include: *Cleistocactus chacoanus*, *Echinopsis klingeriana*, *Gymnocalycium damsii* var *torulosum*, *G. damsii* var *tucavocense*, *G. griseo-pallidum*, *G. pflanzii* var *izozogsii*, *Momvillea chacoana*, *M. ebenacantha*, and *M. parapetiensis*.

#### 4.4.1.2 Temperate Dry Forest

Several vegetation associations are present in this life zone. Their distribution is influenced mainly by variations in soil texture, seasonal floods, fires, and depth of the water table. The two biogeographic formations, the Chaqueña Formation and the Cerrado Formation, can be differentiated according to floristic composition and the vegetation structure.

##### a) Chaqueña Formation

Differences in soil texture, micro relief and seasonal flooding of the Río Parapetí have resulted in a variety of vegetation communities in this formation, which include Sub Humid Chaqueño Forest, Forested Floodplains, Palm Associations, and Riparian Forests.

**Sub-Humid Chaqueño Forest.** This forest is present along the northern border of the study area, between the alluvial plains of the Río Parapetí-Río Grande, forming a belt in the northern, eastern and western portion of the Bañados of Izogog extending to the Puerto Ceres-Maiden area. This forest which grows on clayey/sandy soils has a dense canopy ranging from 15 to 20 meters in height and is dominated by *Diplokeleba floribunda* (Sapindaceae), *Acanthosyris falcata* (Santalaceae), *Aspidosperma pirifolium* (Apocynaceae), *Calycophyllum multiflorum* (Palo blanco, Rubiaceae), *Anadenanthera macrocarpa* (Curupaú, Fabaceae), *Caesalpinia paraguariensis* (Fabaceae), *Astronium urundeuba* (Anacardiaceae), *Schinopsis cornuta* (Anacardiaceae), *Athyana weinmannifolia* (Sapindaceae), *Pseudobombax marginatum* (Bombacaceae), *Phyllostylon rhamnoides* (Ulmaceae), *Tabebuia spicata* (Bignoniaceae), *Zizyphus guaranitica* (Rhamnaceae), *Browningia caineana* (Cactaceae).

The shrub stratum is 3 to 6 meters tall and is characterized by *Achatocarpus praecox*, *A. nigricans* (Achatocarpaceae), *Cordia bordasii* (Boraginaceae), *Neea hermaphrodita* (Nyctaginaceae), *Trithrinax brasiliensis* (Arecaceae), *Randia spinosa* (Rubiaceae), *Celtis iguanea* (Ulmaceae), *Caesalpinia floribunda* (Fabaceae), *Capparis retusa*, *C. tweddiana* (Capparidaceae), *Tabebuia nodosa* (Bignoniaceae), and *Ruprechtia triflora* (Polygonaceae).

The vines include *Arrabidaea corallina* (Bignoniaceae) and species of the genera *Serjania* (Sapindaceae) and *Smilax* (Smilacaceae). Dense communities of the terrestrial bromeliad *Aechmea dystichantha* are very abundant in the understory, and *Bromelia serra* is also present; however, is not as common.

In areas where the water table is elevated and the soils are very permeable and have a sandy texture, particularly in terraces and recent alluvial plains, a community of palms dominated by *Acrocomia aculeata* (Totá, Arecaceae) occurs. This community extends over broad areas of alluvial plains of the Río San Miguel and the Río Aguas Calientes in the vicinity of Naranjos. These palms are commonly associated with trees such as *Pseudobombax marginatum* (Bombacaceae), *Geoffroea striata* (Fabaceae), *Phytocellobium scalare* (Fabaceae), and *Acacia aroma* (Tusca, Fabaceae).

In areas that have been disturbed or affected by fire, *Ipomoea* (Convolvulaceae), an invasive plant appears. Other species of the genera *Cissus* (Vitaceae) and *Cucurbita* (Cucurbitaceae) are also present. Along the edges of the roadways the shrubs *Mimosa cf. pellita* (Fabaceae) and *Solanum glaucophyllum* (Solarraceae) are abundant.

**Forested Floodplains (Bañados).** Two types of formations exist in these forested floodplains, 1) riparian forests (Bañados de Izozog), and 2) palm associations dominated by species such as *Copernicia alba*. These forests have a particular structure and floristic composition and are primarily influenced by the hydrology of the area and the soil type.

- **Riparian Forests.** Riparian forests, characteristic of the Bañados de Izozog region, grow along the Río Parapetí and are tall, ranging in height from 20 to 25 meters. They are very dense semi-deciduous forests that remain flooded the majority of the time. The arboreal



stratum is dominated by *Cathormion polyanthum* (Asotocosi, Fabaceae), *Geoffroea striata*, and *Phytocellobium scalare* and are associated with less frequent trees such as *Guazuma ulmifolia* (Sterculiaceae), *Ziziphus guaranitica* (Rhamnaceae), and *Caesalpinia paraguariensis* (Fabaceae).

The shrub stratum is characterized by *Crataeva tapia* (Capparidaceae), *Phyllanthus chacoensis* (Euphorbiaceae), *Achatocarpus nigricans* (Achatocarpaceae), *Casearia aculeata* (Flacourtiaceae), and *Aegiphila sordida* (Verbenaceae).

Vines are very common and are dominated by *Hippocratea volubilis* (Celastraceae), *Melloa quadrivalvis* (Bignoniaceae), and *Forsteronia* sp. (Apocynaceae). The epiphytes include *Tillandsia duratti* (Bromeliaceae), *Ripsalis leucoraphis* (Cactaceae), *Epiphyllum phyllanthus* (Cactaceae) and species of the genus *Philodendron* (Araceae). In areas where the forest has been disturbed, *Ipomoea* (Convolvulaceae), which is invasive, is locally abundant.

- **Palm Associations.** The palm associations are very common in areas inundated by ponded water. These areas are characterized by palms such as *Copernicia alba* (Caranday, Arecaceae) and are located in the Bañados de Izozog region, the Tacuaral and Bañados de Otuquis region, and the Puerto Ceres region. These palms are frequently associated with smaller trees or shrubs such as *Prosopis nigra*, *Geoffroea striata*, *Parkinsonia aculeata* (Fabaceae), *Tabebuia nodosa* (Bignoniaceae), and *Cocoloba* sp (Polygoniaceae). Ponded soils show dense graminoid cover dominated by species of the genera *Panicum*, *Paspalum*, *Cyperus*, *Rhynchospora* and a rooted aquatic species of the genus *Typha* (Typhaceae).

## b) Cerrado Formation

This formation is located in the northern part of the study area near the sierra of San José de Chiquitos and extends towards Roboré and finally to the easternmost region of the sierra of Maiden. Different types of forests can be distinguished according to the structure and composition of the vegetation which are influenced by the substrate on which they grow and the rainfall distribution.

**Tall Semi-Deciduous Sub-Humid Forest.** This forest grows at the foothill of the mountains and in the depressions of the mountainous areas on moist deep soil. This forest ranges from 12 to 20 meters in height, and includes, *Astronium urundeuba*, *Anadenathera macrocarpa*, *Hymenaea curbaril*, *Caesalpinia floribunda*, *Pterogine nitens*, *Jacaranda cuspidifolia*, *Attalea pharelata*, *Chorisia speciosa*, and *Pseudobombax marginatum*.

The shrub stratum is very dense ranging in height from 1 to 3 meters and is dominated by *Parkinsonia aculeata*, *Bauhinia aff. pentandra* (Fabaceae), *Prockia crucis* (Flacourtiaceae), *Syagrus petrea* (Arecaceae), and *Lantana spp* (Verbenaceae). The epiphytes include species of the genera *Phylodendron* (Araceae) and *Tillandsia* (Bromeliaceae). Homogeneous communities of *Schelea princeps* (Motacú, Arecaceae) and dense grassy cover dominated by *Elyonurus muticus* (Poaceae) are present in the depressions in very moist soils.

**Open Forest or Forested Savannahs.** Open forest or forested savannah, that originates from seasonal burning, are present in broad areas east and southeast of the serranías de San José de Chiquitos. They grow in moderately permeable sandy to clayey soils. In general, they are dominated by dense shrub with heights ranging from 1 to 3 meters and some small isolated trees. The most common species of trees include *Hymenaea stigonocarpa* (Paquiosillo, Fabaceae), *Plumeria sp.* (Apocynaceae), *Genipa americana* (Bignoniaceae), and *Acrocomia aculeata* (Arecaceae), *Syagrus petrea* (Arecaceae), *Lonchocarpus sp.*(Fabaceae), *Tabebuia aff. impetiginosa* (Bignoniaceae), *Curatella americana* (Dilleniaceae). The grass cover consists of species of the genera *Elyonurus*, *Panicum*, and *Paspalum* (Poaceae).

In small depressions containing shallow surface water and in rivers, some aquatic species are present, including *Nymphoides herzogii*, *Eichornia azurea*, *E. crassipes* (Pontederiaceae), *Pontederia rotundifolia* (Pontederiaceae), and *Typha aff. dominguensis* (Typhaceae).

**Aquatic Vegetation of the Pantanal.** This type of vegetation is located primarily north of the Laguna Cáceres and different communities can be clearly defined by the hydrology. These include grass communities dominated mainly by islands of *Hymenachne amplexicaulis* (Camalotillo, Poaceae) that grow in shallow water, and associated species such as *Hyparrhenia rufa* (Poaceae),

*Panicum boliviense*, *P. elephantipes* (Poaceae), *Echinodorus macrophyllum*, *E. tenellus* (Alismataceae), *Hydrolea spinosa* (Hydrophyllaceae), and *Ludwigia caparosa* (Onagraceae).

Floating aquatic communities consisting primarily of fixed plants in deep waters are commonly surrounded by islands of grass communities characterized by *Nymphaea amazonum* (Nymphaeaceae) and *Victoria amazonica* (Nymphaeaceae). In some areas, communities of royal water lilies are present and consist mainly of free-floating plants including *Eichornia azurea*, *Eichornia crassipes* (Pontederiaceae), and *Pontederia rotundifolia* (Pontederiaceae).

#### 4.4.1.3 Temperate Humid Forest

In the study area, the temperate humid forest is influenced by the Cerrado and the Humid Chaco. The vegetation is represented by tall sub-humid trees which are semideciduous, with heights ranging from 15 to 25 meters. The most common species present include *Astronium urundeuva* (Anacardiaceae), *Schinopsis brasiliensis* (Quebracho colorado), *Calycophyllum multiflorum* (Palo Blanco), *Chorisia speciosa* (Toboroquí), *Pseudobombax marginatum* (Pequí), *Jacaranda cuspidifolia* (Jacarandá), *Dypterix alata* (Almendro, Fabaceae), *Amburana cearensis* (Roble, Fabaceae), *Tabebuia impetiginosa* (Bignoniaceae), and *Pterogine nitens* (Paquí, Fabaceae). The dense understory consists of populations of *Samanea saman* (Penoco, Fabaceae), *Geoffroea decorticans* (Chañar, Fabaceae), *Acacia aroma* (Cupechichó), *Scheelea princeps* (Motacú, Arecaceae), *Ateleia guaraya* (Fabaceae), and *Genipa americana* (Genipapo, Rubiaceae). Along roadways and forest which has been disturbed, herbaceous species of the genera *Mimosa* (Fabaceae) and *Capsicum* (Solanaceae) occur. Epiphytes are represented by species of the genera *Phylodendron* (Araceae), *Tillandsia* (Bromeliaceae), and *Phoradendron* sp. (Loranthaceae), and vines of the families Bignoniaceae, Sapindaceae, and Apocynaceae are common.

#### 4.4.2 Fauna

The fauna present in the study area is diverse and varies according to the life zone and levels of disturbance of the natural habitat. The fauna was described according to the three different life zones described in the subsequent sections.

#### 4.4.2.1 Temperate Thorny Scrub

This area and the fauna present are clearly influenced by the biogeographic regions Chaqueña and Andino-Patagónica.

**Mammals.** Mammals are the most affected by human activities such as the clearing of large areas of land for agriculture, large cattle ranching operations, logging activities, development of access roads, and selective hunting of large mammals. Hunting largely affects the density of the populations of large species such as peccaries, tapir, and monkeys. Affected species include *Tayassu tajacu* (Pecarí), *T. albirostris* (Tropero), *Catagonus wagneri* (Chanco rosillo), *Alouatta caraya* (Mono Araña), *Mazama americana* (Urina), *Tapirus terrestris* (Anta), *Dasyus novemcinctus* (Tatú), *Priodontes maximus* (Tatú carreta), and *Tolypeutes tricinctus*, which are hunted for their skin and meat. Cattle breeders in the area have also contributed to the decline of the feline populations, particularly the jaguar (*Panthera onca*) and the puma or lion (*Felis concolor*), as they claim that these species attack their cattle. All these species are included in the list created by the Convention on International Trade of Endangered Species (CITES) or are considered special in that they require protection and a management plan for communities located in the vicinity of the species' natural habitat.

Other species commonly found in this life zone include *Didelphis azarae* (Comadreja overa), *Coendu prehensilis* (Puerco espín), *Agouti paca* (Jochi), *Silvilagus brasiliensis* (Tapetí), *Nasua nasua* (Tejón), *Speothos venaticus* (zorro), and *Desmodus rotundus* (Murciélago vampiro).

**Avifauna.** The group of birds in this life zone have an Andean-Patagonian influence in the south and east and also represent the dispersal limits of some Amazonian avifauna. The most common of these include parrots, toucans and wading birds. Common species include *Ortalis canicollis* (Charata), *Crax fasciolata* (Pava pintada), *Zenaida auriculata* (Torcaza), *Myopsitta monachus* (Cotorra), *Aratinga acuticaudata* (Loro or Tarechi), and *Cariama cristata* (Socorí). In areas with surface water and along the border of watercourses the following herons are present: *Platalea ajaja* (Garza espátula), *Bubulcus ibis* (Garza blanca bueyera), *Syrigma sibilatrix* (Garza silvadora), *Ardea cocoi* (Garza mora mora), and *Egretta thula* (Garza blanca). Some ciconides are also

present and include *Jabiru mycteria* and *Mycteria americana* (Bato cabeza seca). Vultures of the species *Cathartes aura* (Sucha) and *C. burruvianus* (Sucha) are common.

**Reptiles.** The most important reptile species include the tortoise *Geochelone chilensis* (Peta), *Geochelone carbonaria* (Peta), *Tupinambis tequixín* (Peni o iguana), and poisonous snakes such as *Lachesis muta muta* (Pucarara), and *Botrops atrox* (Yope).

#### 4.4.2.2 Temperate Dry Forest

This life zone has a high species diversity due to the fact that it represents the limits of distribution of Amazonian species of the biogeographic region of the Amazon in the north, the Andean-Patagonian region in the south and west, and the biogeographic region of the Cerrado in the west.

A variation in the population density of animals in this life zone exists, particularly with avifauna as there are dense populations in areas of open forest which are influenced by water courses.

**Mammals.** The majority of the mammals present in this life zone have extensive distributions in this part of the continent, however, this area also represents the southern limit of dispersion of large Amazonian mammals like *Tapirus terrestris* (Anta), *Tayasu tajacu*, *T. pecari* (Chanco de monte), *Hydrochaeris hydrochaeris* (Capivara), *Mazama gouazoubira*, *M. americana* (Urina), *Ozotocerus bezoarticus* (Venado), *Panthera onca* (Jaguar, Tigre), *Felis concolor* (León, Puma). A marsh deer, *Blastocerus dichotomus*, is present and has a dense population in the Pantanal region, but is also widely distributed in the Amazonian region reaching south to Uruguay. Some primates of the Cerrado region with tendencies to distribute towards the Chaco include *Callicebus moloch pallescens*, *Cebus apella paraguayensis* and *Callithrix argentata melanura*. A canid, *Chrysocyon brachyurus* (Borocho), has similar distribution patterns. It also has a dense population in the mountainous area of Mutún and occurs towards the north of the Amazon.

Some species of the Chaqueña area which are present include *Catagonus wagneri* (Chocó), *Alouatta caraya*, *Chaetophractus vellerosus*, and *C. villosus* (Armadillos). This last group is associated with other species with wide distribution including *Myrmecophaga tridactyla* (Oso

bandera), *Tamandua tetradactyla* (Tamandúa, Oso hormiguero), *Priodontes maximus* (Pejichi, Tatú carreta), *Dasypus novemcinctus* (Tatú), *Sylvilagus brasiliensis brasiliensis* (Liebre, Tapetí), *Felis geoffroyi* (Gato montés), *Felis pardalis* (Ocelote), *Dusicyon gymnocercus* (Zorro), and *Nasua nasua* (Tejón). In the Pantanal area, species characteristic of flooded zones are present and include *Pteronura brasiliensis* (Nutria) and *Lutra platensis* (Nutria).

The most pursued and threatened species in this group include large mammals such as deer, wild pigs, and large cats that are hunted for their meat and skin. The group of felines is hunted indiscriminately because they are considered a threat to the cattle which occupy a broad area of the woodland.

In the Pantanal region, as a result of intensive hunting of *Pteronura brasiliensis* and *Lutra platensis*, their populations are declining and are in danger of extinction.

In the Chaqueña area there is an abundance of large mammals such as *Tapirus terrestris* in the humid zone. In drier, more desolate areas, felines such as *Panthera onca* and *Felis concolor* are common.

**Avifauna.** The avifauna exhibits Amazonian influences from the north and Andean-Patagonian influences from the south and southwest. In forests of the Chaco the most common species are *Ortalis canicollis* (Charata), *Zenaida auriculata* (Torcaza), *Amazona aestiva* (Loro hablador), *Aratinga acuticaudata* (Tarechi), *Myopsitta monachus* (Cotorrita), *Ramphastos toco*, *R. cuvieri* (Tucán), *Campephilus leucopogon* (Carpintero), and *Paroaria coronata* (Cardenal). The most common species in open areas or forested savannahs include the American ostrich *Rhea americana* (Pío, Ñandú), *Cariama cristata* (Socorí), *Chunga burmeisteri* (Socorí), and *Nothoprocta cinerascens* (Perdíz). There is also evidence of large populations of vultures and related species such as *Cathartes aura* (Sucha), *C. burruvianus* (Sucha), *Sarcoramphus papa* (Condor blanco), *Coragyps atratus* (Gallinazo), and *Polyborus plancus* (Carancho).

In the Pantanal and the Bañados de Izozog area, and in Isla Verde, large concentrations of ciconides and herons are present. These include *Jabiru mycteria* (Bato, Tuyuyú), *Mycteria americana* (Bato cabeza seca), *Ciconia maguari* (Cigueña), *Platalea ajaja* (Garza espátula),

*Casmerodius albus* (Garza blanca), *Nycticorax nycticorax* (Pato cuervo), *Syrigma sibilatrix* (Garza silvadora), *Anhinga anhinga* (Pato víbora) *Egretta thula* (Garza), *Bubulcus ibis* (Garza bueyera), and *Cairina moschata* (Pato montés). Along the edge of rivers and lagoons, the following species were observed: *Fulica gigantea* (Gallareta gigante), *Porphyryla martinica* (Polla de agua), *Vanellus chilensis* (Leque leque), and *Chauna torquata* (Chajá). In this life zone, endemic species such as *Anodorhynchus hyacinthinus* (Paraba jacinta) are present.

**Reptiles.** In the pantanal area, a species characteristic of this zone, the caiman *Caiman yacare* (Yacare), is intensively pursued in the Bolivian side, as hunting restrictions are non-existent. Other typical species include *Caiman latirostris* (Caiman), *Tupinambis rufescens* (Peni, Iguana colorada), and *Tupinambis teguixin* (Iguana overa), an aquatic lizard of the Pantanal. The snakes *Dracaena paraguayensis*, *Boa constrictor* (Boyé), *Eunectes notaeus* (Sicuri), and *Botrops alternata* (Yarará) are very well distributed throughout the Chaco. *Micrurus frontalis* (Coral), *Lachesis muta muta* (Pucarara), *Crotalus durissus* (Cascabel), *Geochelone carbonaria* (Peta), and *G. chilensis* (Peta) are also present in this life zone.

One species which is threatened due to intense hunting is the *Caiman yacare*. It is hunted for the skin and in some cases for consumption of the tail of the body. In some communities, it has been observed that the skin of these reptiles is a common hunting trophy, and in the Puerto Suárez community some restaurants serve typical dishes that consist of the meat from the tail of the cayman.

**Fish.** To our knowledge, no studies on the ichthiofauna characteristic of this life zone have been produced, however, the majority of populations for this group are found in the Pantanal area and include a large diversity of species. The most common species include *Pseudoplatistoma fasciatum* (Surubí), *Colossoma macropomum* (Pacú), *Serrasalmus nattereri*, *S. rhombeus*, *S. spiroleura* (Piraña, Palometa), *Prochilodus lineatus* (Sábalo), *Hoplias malabaricus* (Bentón), and *Salminus maxillosus* (Dorado).

**Amphibians.** This group is not well known in this region, however, the frogs *Hyla raniceps* (rana) and *Phrynohyas hebes* have been cited as the most common in the Pantanal area. They

distribute towards Paraguay and the center of Brazil, but always in aquatic environments. In the Chaco, the frog *Leptodactylus bufonius* and the toad *Bufo major* are present.

#### 4.4.2.3 Temperate Humid Forest

From a biogeographic point of view, the Temperate Humid Forest is clearly influenced by the biogeographic region of the Cerrado in the east, the Andean-Patagonian and Chaqueña region in the south and southwest, and by the Amazonian region in the north.

The diversity of the fauna in this life zone is mainly the same as that which is present in the Temperate Dry Tropical Forest, with the exception of decreased density of species such as *Hidrochaeris hidrochaeris*, *Jabiru mycteria*, and *Caiman yacare*, and the absence of some species (particularly in the fish group) due to a lack of inundated areas.

### 4.5 ENVIRONMENTAL SENSITIVITY

The study area was classified into three categories of environmental sensitivity (Figure 4.18) which reflect how susceptible the environment is to the anticipated effects of the project. The sensitivity of both the physical and the biological environments were considered and incorporated into the classification.

The classification resulted in the following partition of the study area:

- *High Environmental Sensitivity.* The area of the Gran Chaco National Park and the adjacent Bañados de Izozog are highly sensitive to the project. The national park was instituted to protect the largest tract of pristine subtropical dry forest in the Americas and is an area rich in biodiversity, habitat for several large mammals under intense hunting pressure, and high in floral endemism. Biogeographically, this area represents the interface between the Amazon, the Andes, and the Patagonian regions. Furthermore, this area also harbors indigenous people.



- *Medium Environmental Sensitivity.* This category includes the following:
  - Areas of potential slope instability, which would present constraints to the construction and integrity of the pipeline. These areas are associated with the foothills of the Sierras Chiquitanas.
  - Areas of relatively high potential for aeolic erosion. The savannahs associated with the Río San Miguel are more susceptible to erosion than the dry, forested areas within the study area.
  - The floodplain of the Río Grande, which is associated with historical river channel modifications and supports relatively rich soils with agricultural potential.
- *Low Environmental Sensitivity.* This category includes the balance of the study area. These areas are either disturbed by human use or, if under natural vegetation cover, appear resilient to the types of effects anticipated with the construction of the pipeline.

TABLE 4.1 HYDROLOGIC CHARACTERISTICS FOR RIVERINE SYSTEMS IN THE STUDY AREA						
RIVER AND REFERENCE GAGE STATION	BASIN AREA KM <sup>2</sup>	MEAN ANNUAL VOLUME HM <sup>3</sup>	MEAN ANNUAL FLOWRATE M <sup>3</sup> /S	AVERAGE ANNUAL SEDIMENT		
				TONS X 10 <sup>6</sup>	G/L	TONS/HA
Rio Grande at Abapo	60800	8947	283.7	161.5	18.2	26.56
Rio Parapeti at San Antonio	7490	1793	56.8	13.5	6.2	18.02
Rio San Miguel at Fortin Suarez Arana	1978	37	1.17			
Rio Aguas Calientes at confluence w/Rio Tucavaca	5856	183	- 5.82			
Rio Otoquis (Rio Aguas Calientes + Rio Tucavaca)	14656	452	14.34			

Data for this table was compiled from CUMAT 1990.

**TABLE 4.2**  
**LIST OF ENDEMIC, ENDANGERED, AND ECONOMICALLY IMPORTANT PLANT AND ANIMAL SPECIES IN THE STUDY AREA**

PLANTS							
COMMON NAME	SCIENTIFIC NAME	FAMILY	GROWTH FORM	USES	HABITAT	STATUS	SOURCE
Cuchi, Urundel	<i>Astronium urundeuva</i>	ANACARDIACEAE	Tree to 20 m.	Timber, medicinal	Forests of the Cerrado, subhumid-humedo Chaco	Threatened, excessive cutting	Bibliography
Guayacan	<i>Bulnesia sarmientoi</i>	ZIGOPHYLLACEAE	Tree to 20 m	Timber, essential oils	Forests of the Chaco	Threatened	CITES, Bibliography
Alcornoque	<i>Tabebuia aurea</i>	BIGNONIACEAE	Tree to 6 m	Forestry, medicinal	Wooded savannahs of the Cerrado	Very frequent	Bibliography
Ajo ajo	<i>Gallesia integrifolia</i>	PHYTOLACACEAE	Tree to 20 m	Forestry, medicinal	Forests of the Cerrado, gallery forests	Very frequent	Bibliography
Chaáco	<i>Curatela americana</i>	DILLENiaceae	Tree to 5 m	Medicinal	Wooded savannahs	Very frequent	Bibliography
Cupesí	<i>Prosopis chilensis</i>	FABACEAE	Tree to 12 m	Forestry, medicinal	Alluvial plains in forests of the Chaco	Very frequent	Bibliography
Curupaú	<i>Anadenanthera colubrina</i>	FABACEAE	Tree to 15 m	Forestry, medicinal	Tall forest of the Cerrado	Very frequent	Bibliography
Cusi	<i>Attalea phaleratta</i>	ARECACEAE	Palm to 15 m	Forestry, oil extraction, medicinal	Forests of the Cerrado	Very frequent	Bibliography

Table 4.2 continuation...

PLANTS							
COMMON NAME	SCIENTIFIC NAME	FAMILY	GROWTH FORM	USES	HABITAT	STATUS	SOURCE
Carandai	<i>Copernicia alba</i>	ARECACEAE	Palm to 15 m	Leaves used for hats, trunk for posts, ornamental	Marsh areas, Bafiados, Pantanal	Very frequent	Bibliography
Caparosa	<i>Victoria amazonica</i>	NYMPHACEAE	Aquatic plant, floating leaves	Medicinal, ornamental	Ponds, Pantanal	Very frequent	Bibliography
Coco	<i>Guazuma ulmifolia</i>	STERCULIACEAE	Tree to 12 m	Forestry, medicinal	Gallery forests	Frequent	Bibliography
Guayacán	<i>Caesalpinia paraguariensis</i>	FABACEAE	Tree to 12 m	Forestry	Gallery forests	Frequent, need to protect	Bibliography
Motacuchi	<i>Allagoptera leucocalyx</i>	ARECACEAE	Stemless palm	Medicinal, essential oils extracted from seeds	Wooded savannahs	Very frequent	Bibliography
Paraparau	<i>Jacaranda cuspidifolia</i>	BIGNONIACEAE	Tree to 12 m	Forestry, medicinal	Wooded savannahs, forests of the Cerrado	Very frequent	Bibliography
Penoco	<i>Samanea saman</i>	FABACEAE	Tree to 8 m	Medicinal	Wooded savannahs	Very frequent	Bibliography
Paquió	<i>Hymenaea courbaril</i>	FABACEAE	Tree to 7 m	Forestry, used for making tools	Forests of the Cerrado, Subhumid Chaco	Frequent	Bibliography
Soto	<i>Schinopsis brasiliensis</i>	ANACARDIACEAE	Tree to 15 m	Forestry, used for making tools	Forests of the Cerrado, Subhumid Chaco	Frequent	Bibliography

Table 4.2 continuation...

PLANTS							
COMMON NAME	SCIENTIFIC NAME	FAMILY	GROWTH FORM	USES	HABITAT	STATUS	SOURCE
Roble	<i>Amburana cearensis</i>	FABACEAE	Tree to 12 m	Forestry, used for making musical instruments	Forests of the Cerrado	Occasional	Bibliography
Cacha	<i>Aspidosperma quebracho-blanco</i>	APOCYNACEAE	Tree to 20 m	Forestry, used for tracks, posts, constructions	Forests of the Chaco	Frequent	Bibliography
	<i>Cleitocactus chacoanus</i>	CACTACEAE	Columnar to 1 m		Forests of the Chaco	Endemic, dry Chaco	Bibliography
	<i>Echinopsis klingeriana</i>	CACTACEAE	Globular		Forests of the Chaco	Endemic, dry Chaco	Bibliography
	<i>Gymnocalycium damsii var torulosum</i>	CACTACEAE	Globular		Forests of the Chaco	Endemic Chaco	Bibliography
	<i>Gymnocalycium damsii var tucavocense</i>	CACTACEAE	Globular		Forests of the Chaco	Endemic Chaco	Bibliography
	<i>Gymnocalycium griseo-pallidum</i>	CACTACEAE	Globular		Forests of the Chaco	Endemic Chaco	Bibliography
	<i>Gymnocalycium pflanzii var izozogsii</i>	CACTACEAE	Globular		Forests of the Chaco	Endemic Chaco	Bibliography
	<i>Monvillea chacoana</i>	CACTACEAE	Columnar		Forests of the Chaco	Endemic Chaco	Bibliography
	<i>Monvillea ebenacantha</i>	CACTACEAE	Columnar		Forests of the Chaco	Endemic Chaco	Bibliography

Table 4.2 continuation...

PLANTS							
COMMON NAME	SCIENTIFIC NAME	FAMILY	GROWTH FORM	USES	HABITAT	STATUS	SOURCE
	<i>Monvillea parapetiensis</i>	CACTACEAE	Columnnar		Forests of the Chaco	Endemic Chaco	Bibliography

Table 4.2 continuation...

ANIMALS					
MAMMALS:					
COMMON NAME	SCIENTIFIC NAME	CATEGORY	CAUSES	HABITAT	SOURCE
Anta	<i>Tapirus terrestris</i>	CITES II	Uncontrolled hunting, habitat destruction, meat consumption	Subhumid forests, wetlands of the Chaco and the Cerrado	Bibliography, CITES
Pecarí	<i>Tayassu tajacu</i>	CITES II	Uncontrolled hunting, meat consumption	Subhumid forests, wetlands of the Chaco and the Cerrado	Bibliography, CITES
Tropero	<i>Tayassu albirostris</i>	CITES II	Hunting, meat consumption	Subhumid forests, wetlands of the Chaco and the Cerrado	Bibliography, CITES
Choco	<i>Catagonus wagneri</i>	CITES I, endemic	Hunting, meat consumption	Subhumid forests, wetlands of the Chaco	Bibliography
Urina	<i>Mazama americana</i>	Threatened	Hunting, meat consumption	Forests of the Cerrado and the Chaco	Bibliography
Pejichi, Tatú carreta	<i>Priodontes maximus</i>	Threatened	Habitat destruction	Forests of the Cerrado and the Chaco	Bibliography
Jaguar, Tigre	<i>Panthera onca</i>	Threatened	Habitat destruction, uncontrolled hunting, fur trade	Forests of the Cerrado and the Chaco	Bibliography
León, Puma	<i>Felis concolor</i>	Threatened	Habitat destruction, uncontrolled hunting	Forests of the Cerrado and the Chaco	Bibliography
Ciervo de los pantanos	<i>Blastocerus dichotomus</i>	CITES I	Uncontrolled hunting, meat consumption	Bañados and Pantanal areas	Bibliography, CITES

Table 4.2 continuation...

MAMMALS:					
COMMON NAME	SCIENTIFIC NAME	CATEGORY	CAUSES	HABITAT	SOURCE
Venado	<i>Ozotocerus bezoarticus</i>	Threatened	Hunting, meat consumption	Forests of the Chaco and the Cerrado	Bibliography
Capibara, Carpincho	<i>Hydrochaeris hydrochaeris</i>	Threatened	Hunting, meat consumption, fur trade	Ponds of the Pantanal and Bañados	Bibliography
Londra	<i>Pteronura brasiliensis</i>	CITES II, endangered	Hunting, fur trade	Ponds of the Pantanal, Bañados, and rivers	Bibliography, CITES
Lobito de río	<i>Lutra longicaudis</i>	CITES II, endangered	Hunting, fur trade	Ponds of the Pantanal, Bañados, and rivers	Bibliography, CITES
Boroichi	<i>Chrysocyon brachiurus</i>	CITES	Habitat destruction	Hills and forests of the Cerrado and the Chaco	Bibliography, CITES
Mono araña	<i>Alouatta caraya</i>	CITES II	Habitat destruction	Subhumid-humid forests of the Cerrado and the Chaco	Bibliography, CITES

BIRDS:					
COMMON NAME	SCIENTIFIC NAME	CATEGORY	CAUSES	HABITAT	SOURCE
Paraba jacinta	<i>Anodorhynchus hyacinthinus</i>	CITES I, endemic	Trading, habitat destruction	Mountainous areas of the Mutún	Bibliography, CITES
Paraba roja	<i>Ara chloroptera</i>	CITES II, need to protect	Trading	Forests of the Cerrado and the Chaco	Bibliography, CITES
Tuyuyú, Bato	<i>Jabiru mycteria</i>	Need to protect	Habitat destruction	Area of the Pantanal, Bañados	Bibliography
Bato cabeza seca	<i>Mycteria americana</i>	Need to protect	Habitat destruction	Area of the Pantanal, Bañados	Bibliography



Table 4.2 continuation...

BIRDS:					
COMMON NAME	SCIENTIFIC NAME	CATEGORY	CAUSES	HABITAT	SOURCE
Cigüeña	<i>Ciconia maguari</i>	Need to protect	Habitat destruction	Area of the Pantanal, Bañados	Bibliography
Pato negro	<i>Cairina moschata</i>	Need to protect	Hunting, meat consumption	Ponds, Pantanal, and Bañados	Bibliography
Pava pintada	<i>Penelope jacquacu</i>	Endangered	Hunting, meat consumption	Forests of the Cerrado and the Chaco	Bibliography
Loro hablador	<i>Amazona aestiva</i>	CITES II, to protect	Commercialization	Forests of the Cerrado and the Chaco	Bibliography
Piyu, Ñandu	<i>Rhea americana</i>	Need to protect	Habitat destruction	Wood savannahs of the Cerrado	Bibliography
Cardenal	<i>Paroaria coronata</i>	CITES II, need to protect	Commercialization	Forests of the Cerrado and the Chaco	Bibliography; CITES
Tucán	<i>Ramphastos toco</i>	Threatened	Commercialization	Forests of the Cerrado and the Chaco	Bibliography

REPTILES:					
COMMON NAME	SCIENTIFIC NAME	CATEGORY	CAUSES	HABITAT	SOURCE
Peta	<i>Geochelone carbonaria</i>	CITES II, threatened	Hunting	Forests of the Cerrado and the Chaco	Bibliography
Lagarto	<i>Caiman yacare</i>	CITES II, endangered	Hunting, meat consumption, skin trading	Area of the Pantanal and Bañados	Bibliography, CITES
Iguana colorada, peni	<i>Tupinambis rufescens</i>	Threatened	Hunting, meat consumption	Region of the Cerrado and the Chaco	Bibliography
Peni	<i>Tupinambis teguixin</i>	CITES II, threatened	Hunting, meat consumption	Region of the Cerrado and the Chaco	Bibliography, CITES

Table 4.2 continuation...

REPTILES:					
COMMON NAME	SCIENTIFIC NAME	CATEGORY	CAUSES	HABITAT	SOURCE
Sicurí	<i>Eunectes notaeus</i>	Threatened	Hunting, skin trading	Region of the Pantanal and Bañados	Bibliography
Boyé	<i>Boa constrictor</i>	Threatened	Hunting, skin trading	Region of the Cerrado and the Chaco	Bibliography

FISHES:					
COMMON NAME	SCIENTIFIC NAME	CATEGORY	CAUSES	HABITAT	SOURCE
Surubí	<i>Pseudoplatistoma fasciatum</i>	Threatened, require management plan	Uncontrolled fishing, meat consumption	Area of the Pantanal	Bibliography
Pacú	<i>Colossoma macropomum</i>	Require management plan	Uncontrolled fishing, meat consumption	Area of the Pantanal	Bibliography
Dorado	<i>Salminus maxillosus</i>	Require management plan	Uncontrolled fishing, meat consumption	Area of the Pantanal	Bibliography

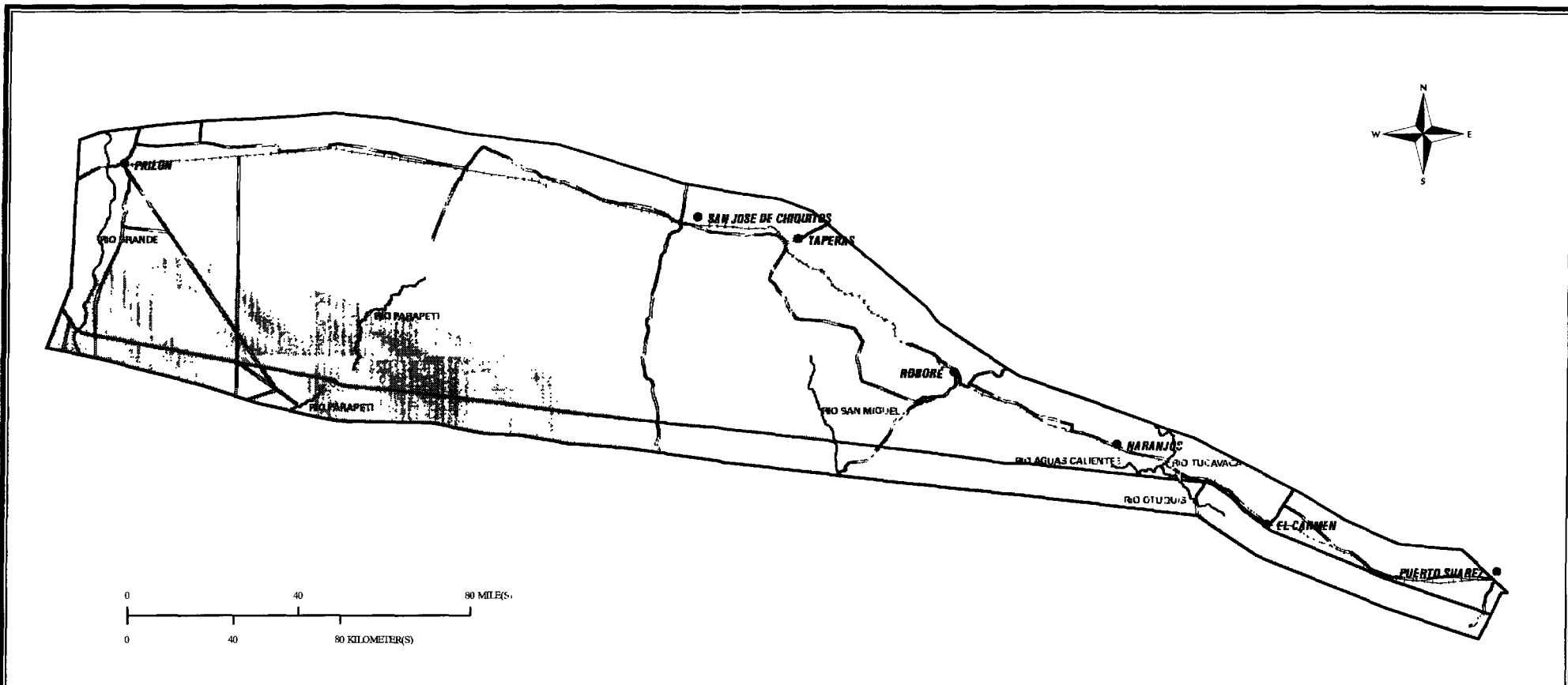

### Legend



Temperate Thorny Scrub



Temperate Dry Forest



Temperate Humid Forest



Major Roads



Railroad



Study Area



Rivers



Gas Pipeline



Major Towns

### Bolivia to Brazil Gas Pipeline (Bolivian Portion)

Figure 4.1

### Area of Influence Showing Life Zones



DAMES & MOORE

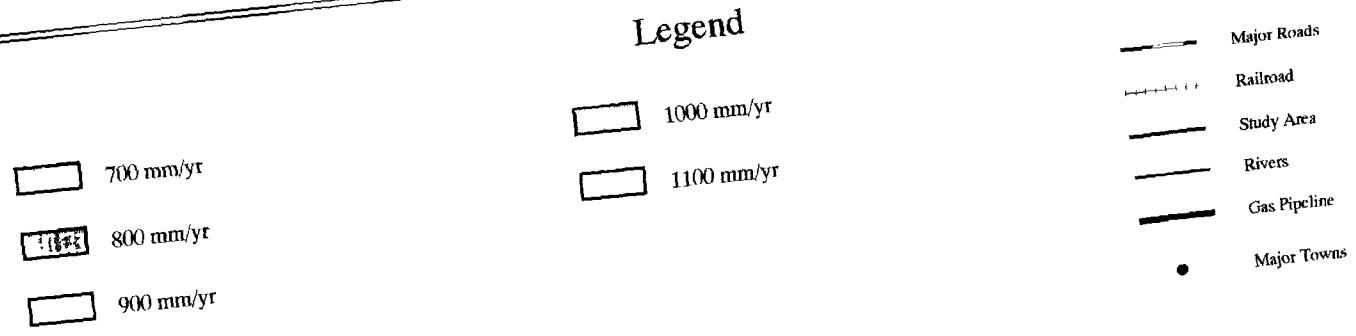
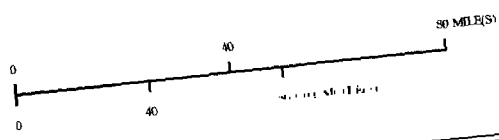
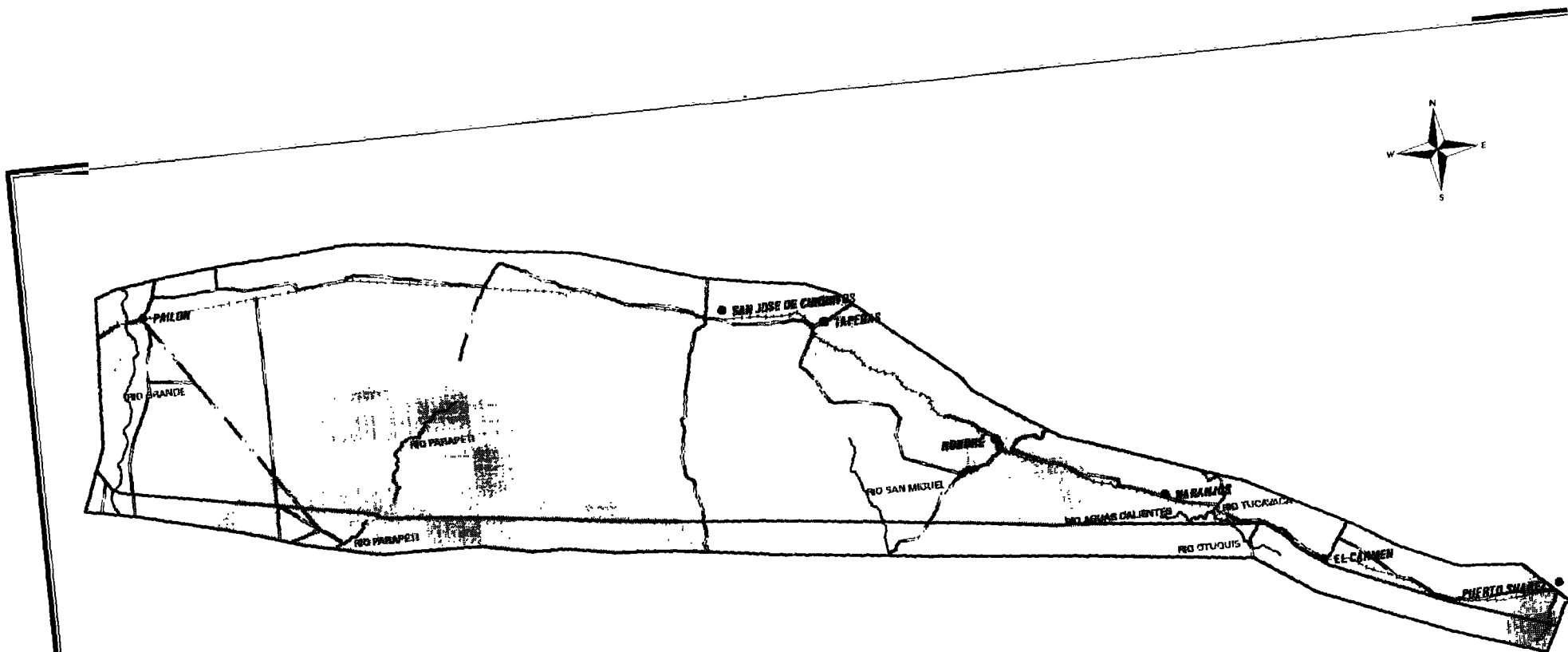

**Bolivia to Brazil Gas Pipeline  
(Bolivian Portion)**

Figure 4.2

**Precipitation**



Date: 06/2/96



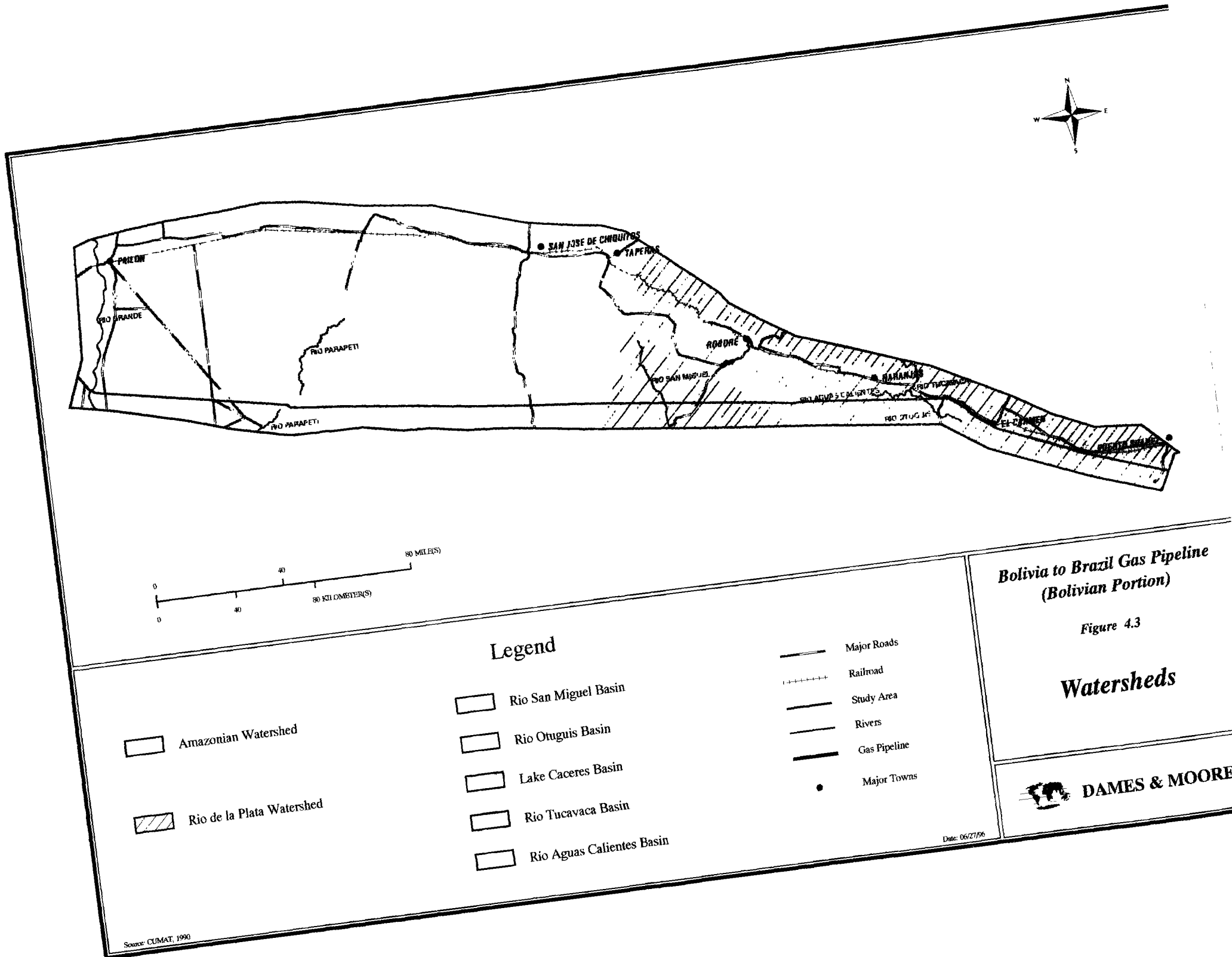









Source: CUMAT, 1990



**Bolivia to Brazil Gas Pipeline  
(Bolivian Portion)**

Figure 4.3

**Watersheds**

- Legend**
-  Amazonian Watershed
  -  Rio de la Plata Watershed
  -  Rio San Miguel Basin
  -  Rio Otuguis Basin
  -  Lake Caceres Basin
  -  Rio Tucavaca Basin
  -  Rio Aguas Calientes Basin
  -  Major Roads
  -  Railroad
  -  Study Area
  -  Rivers
  -  Gas Pipeline
  -  Major Towns



Date: 06/27/96

Source: CUMAT, 1990



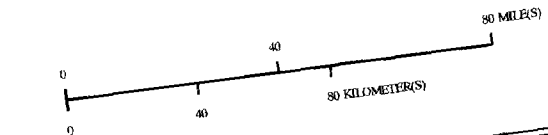
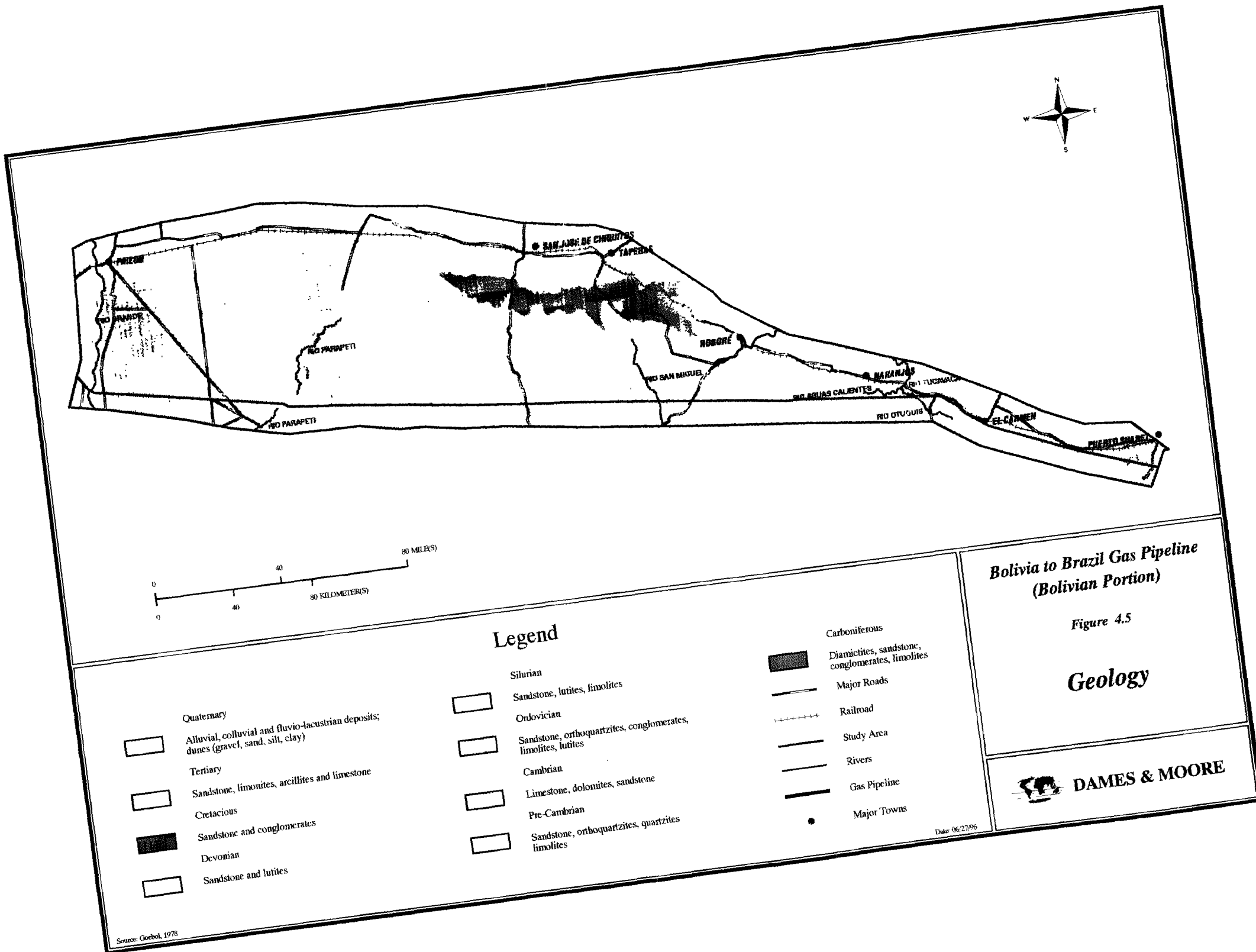

**Legend**

- |  |  |   |
|--|--|---|
| <ul style="list-style-type: none"> <li> Quaternary</li> <li> Alluvial, colluvial and fluvio-lacustrine deposits; dunes (gravel, sand, silt, clay)</li> <li> Tertiary</li> <li> Sandstone, limonites, arcillites and limestone</li> <li> Cretaceous</li> <li> Sandstone and conglomerates</li> <li> Devonian</li> <li> Sandstone and lutites</li> </ul> | <ul style="list-style-type: none"> <li> Silurian</li> <li> Sandstone, lutites, limolites</li> <li> Ordovician</li> <li> Sandstone, orthoquartzites, conglomerates, limolites, lutites</li> <li> Cambrian</li> <li> Limestone, dolomites, sandstone</li> <li> Pre-Cambrian</li> <li> Sandstone, orthoquartzites, quartzites, limolites</li> </ul> | <ul style="list-style-type: none"> <li> Carboniferous</li> <li> Diamicrites, sandstone, conglomerates, limolites</li> <li> Major Roads</li> <li> Railroad</li> <li> Study Area</li> <li> Rivers</li> <li> Gas Pipeline</li> <li> Major Towns</li> </ul> |
|--|--|---|

**Bolivia to Brazil Gas Pipeline (Bolivian Portion)**

Figure 4.5

**Geology**



Date: 06/27/96

Source: Geobel, 1978

BOLIVIA TO BRAZIL GAS PIPELINE (BOLIVIAN PORTION)  
 GEOTECHNICAL/GEOLOGICAL CROSS SECTION OF PROPOSED PIPELINE CROSSING ALIGNMENT RIO GRANDE



FIGURE 4.6

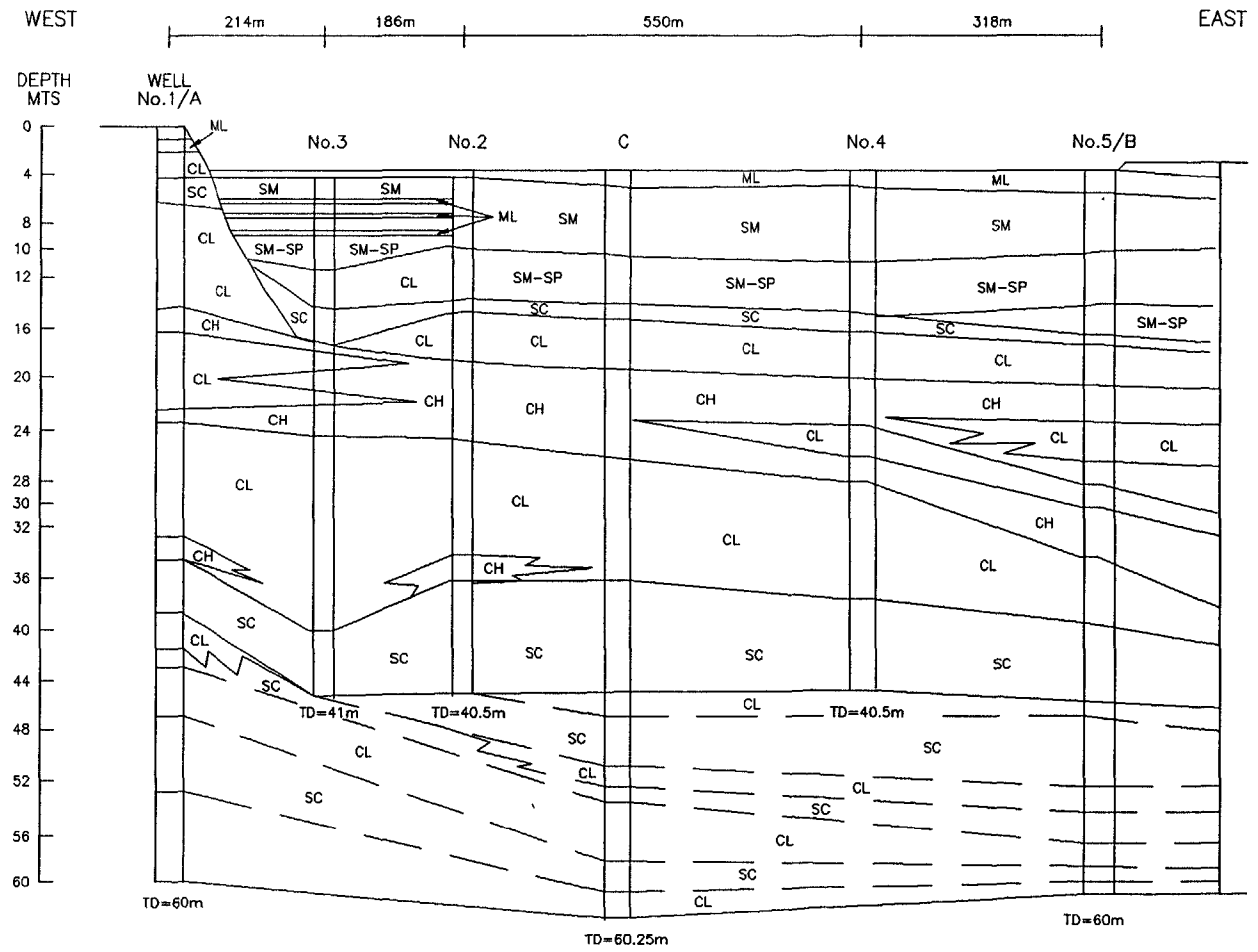

KEY

<span style="border: 1px solid black; padding: 2px;">SM-SP</span> SAND, VARYING TO SILTY SAND	<span style="border: 1px solid black; padding: 2px;">ML</span> SILT
<span style="border: 1px solid black; padding: 2px;">SM</span> SILTY SAND	<span style="border: 1px solid black; padding: 2px;">CL</span> CLAY
<span style="border: 1px solid black; padding: 2px;">SC</span> CLAYEY SAND	<span style="border: 1px solid black; padding: 2px;">CH</span> HIGHLY PLASTIC CLAY

SOURCE: SADAD Q., UNDATED  $\alpha$ ; YPFB, 1994



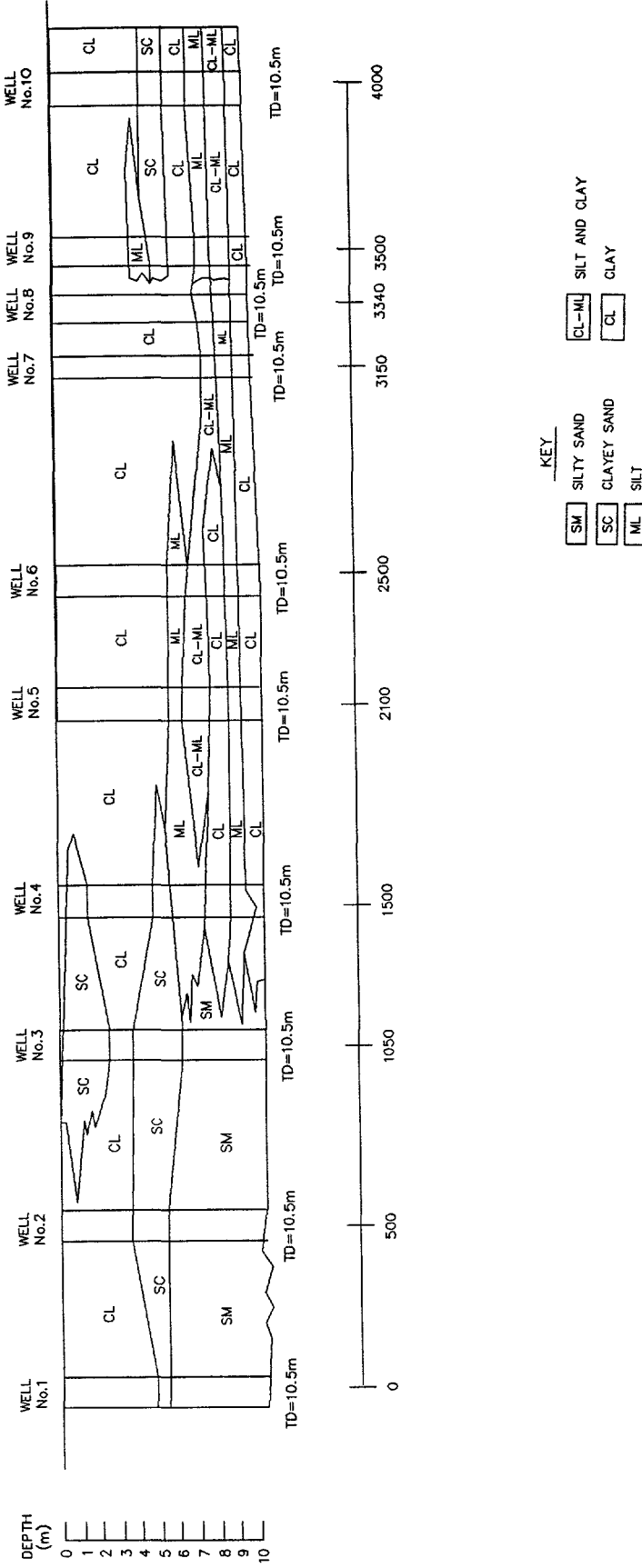

SOURCE: SADAD Q., UNDATED BY: YPFB,1994

**BOLIVIA TO BRAZIL GAS PIPELINE (BOLIVIAN PORTION)**  
**GEOTECHNICAL / GEOLOGICAL CROSS SECTION OF PROPOSED PIPELINE CROSSING ALIGNMENT RIO PARAPETI**



FIGURE 4.7

AGE		FORMATION	THICKNESS m	LITHOLOGY
TERTIARY	MIOCENE	TARIQUIA (LOWER CHACO)	> 1,650	
		YECUA	140	
		PETACA	120	
CRETACEOUS	MAASTRICHTIAN	CAJONES	360	
	LOW. ?	YANTATA	240	
		ICHOA	> 185	
CARBONIFEROUS	UPPER	MANDIYUTI	ELVIRA	180
		FLORIDA	120	
		ESCARPMENT	> 350	
	LOWER	MACHARETI	TAIGUATI	> 100
			CHORRO	> 200
			TARIJA	> 200
			TUPAMBI	> 150
			SAIPURU	> 90
			IQUIRI	> 85
DEVONIAN	MIDDLE	LOS MONOS	> 1000	

Source: YPFB, Undated

**BOLIVIA TO BRAZIL GAS PIPELINE (BOLIVIAN PORTION)**  
**GENERALIZED STRATIGRAPHIC**  
**CROSS SECTION OF**  
**SANTA CRUZ AREA**  
(WESTERN PORTION OF STUDY AREA)

**Dames & Moore**

FIGURE 4.8

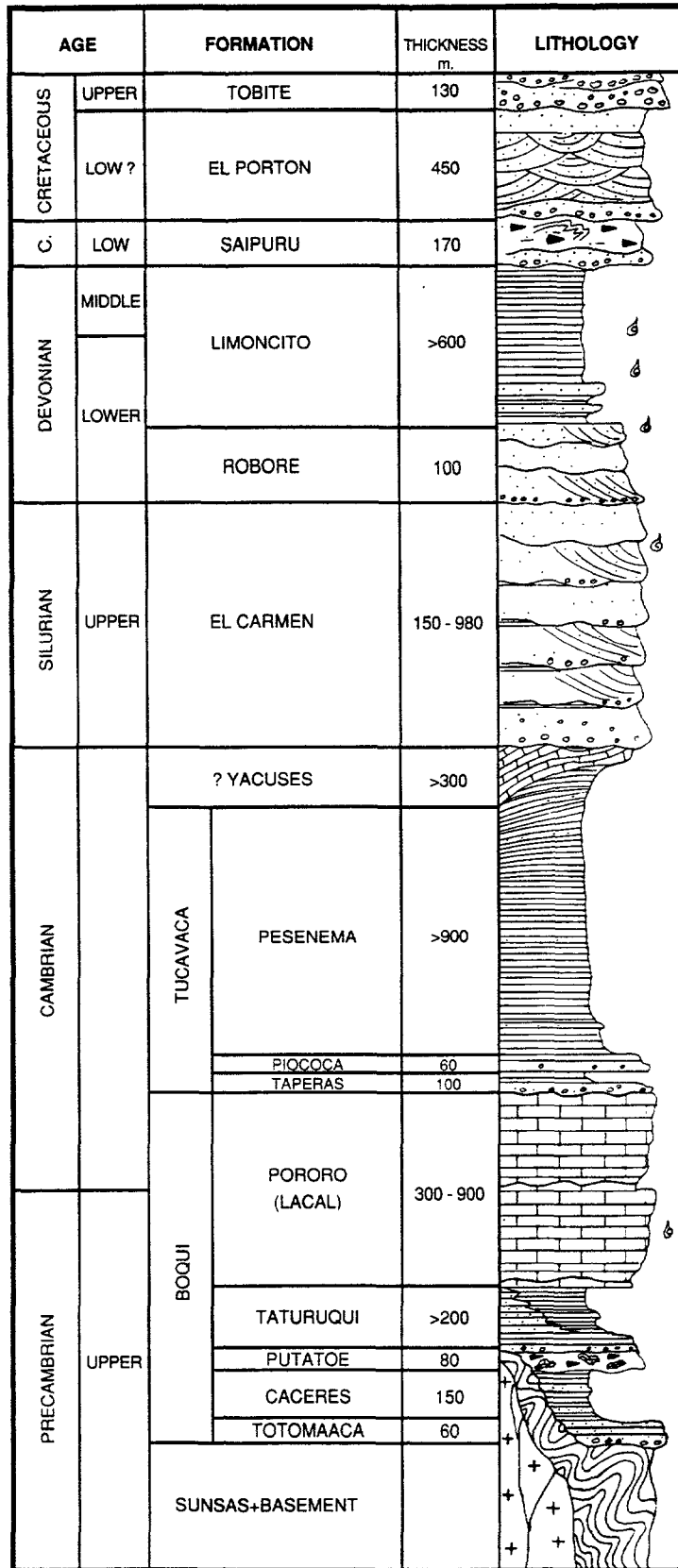

Source: YPFB, Undated

**BOLIVIA TO BRAZIL GAS PIPELINE (BOLIVIAN PORTION)**  
**GENERALIZED STRATIGRAPHIC**  
**CROSS SECTION OF**  
**ROBORE AREA**  
 (EASTERN PORTION OF STUDY AREA)

**Dames & Moore**

FIGURE 4.9

**BOLIVIA TO BRAZIL GAS PIPELINE (BOLIVIAN PORTION)**  
**GENERALIZED STRUCTURAL**  
**CROSS SECTION THROUGH**  
**SOUTHEASTERN PORTION OF**  
**LLANURA CHAQUEÑA**

Source: YPFB, Undated

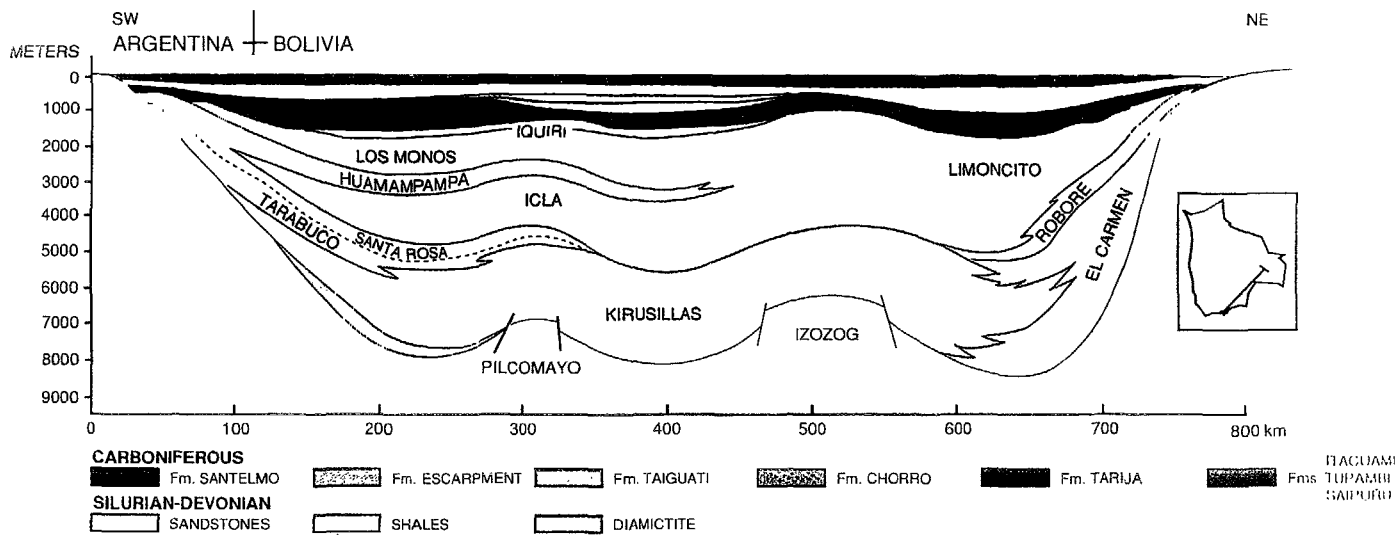

**Dames & Moore**

FIGURE 4.10

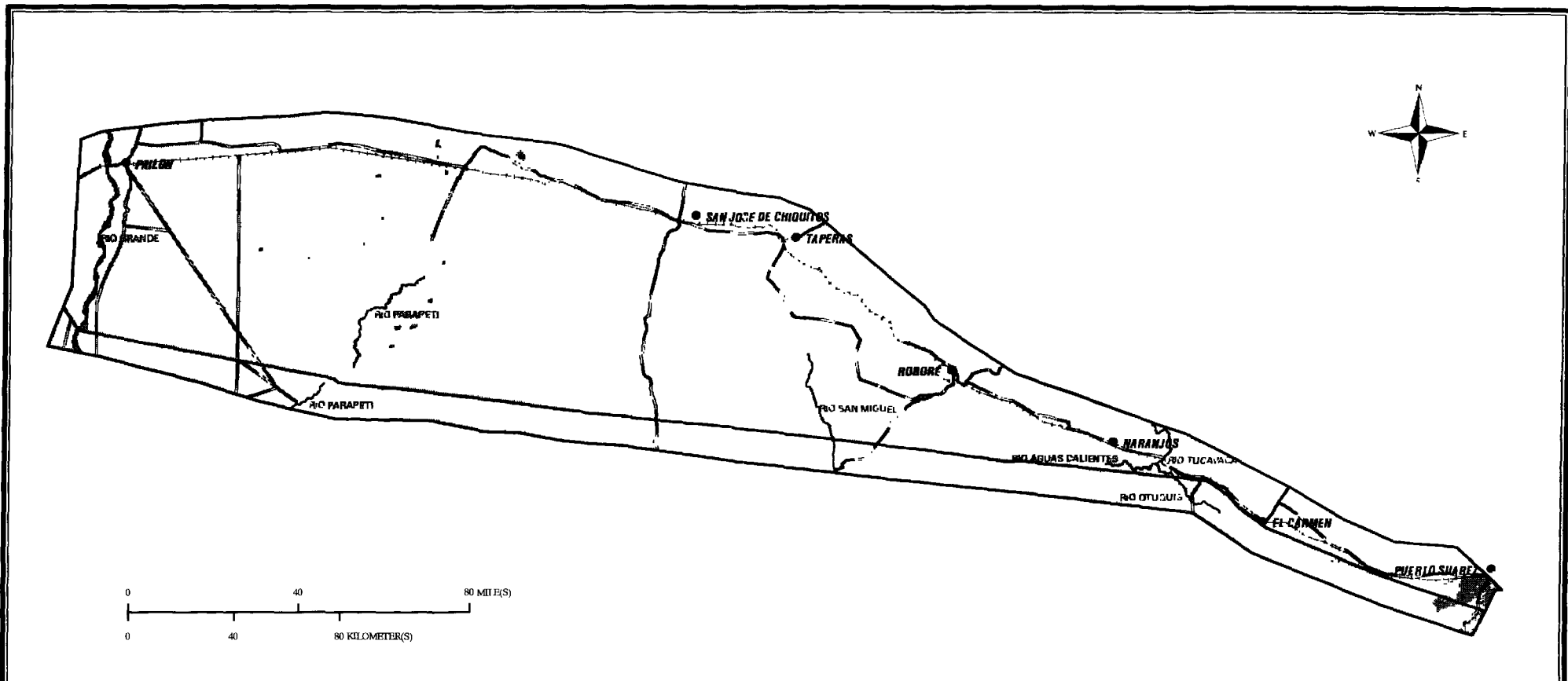

### Legend

- |   |  |  |
|---|--|--|
| <p><b>Chiquitano Shield</b></p> <ul style="list-style-type: none"> <li> Steep slopes. Inceptisols, Oxisols. Low fertility, shallow, hydric erosion</li> <li> Foothills of the Chiquitano Shield. Gentle slopes. Alfisols and Inceptisols. Hardened layers, poor drainage</li> </ul> <p><b>Alluvial Plains</b></p> <ul style="list-style-type: none"> <li> Ancient alluvial plain. Inceptisols, Alfisols, Vertisols; Aridisols in the Chaco. Poor drainage, low fertility, alkaline</li> <li> Floodplain. Hydric Inceptisols and Vertisols. Fine texture, alkaline</li> <li> Recent alluvial plains. Entisols, Inceptisols and Alfisols. Low fertility, coarse, varied drainage</li> <li> Aeolian plains. Entisols and Inceptisols, low fertility, sandy soils on clay, dunes, wind erosion</li> </ul> | <p><b>Pantanal</b></p> <ul style="list-style-type: none"> <li> Floodplain of the Paraguay River. Entisols, Vertisols. Sub-hydric soils, fine texture, periodic flooding up to 5 meters</li> </ul> <p><b>Sierra</b></p> <ul style="list-style-type: none"> <li> Sierra and isolated hills of the Chaco. Entisols, Inceptisols, Alfisols, Oxisols. Low fertility, sandy soils, shallow, hydric erosion</li> </ul> <p><b>Cretaceous and Carboniferous Sediments</b></p> <ul style="list-style-type: none"> <li> Consolidated sediments covered by alluvial materials. Aridisols, Vertisols. Saline, medium to fine texture. Moderate to poor drainage</li> <li> Alluvio-aeolian deposits. Entisols, Inceptisols, Oxisols. Low fertility, sandy, wind erosion, high water table</li> <li> Dissected plateaus of consolidated sediments. Inceptisols, Alfisols, Aridisols. Sandy, very low fertility, aeolian and hydric erosion</li> </ul> | <ul style="list-style-type: none"> <li> Major Roads</li> <li> Railroad</li> <li> Study Area</li> <li> Rivers</li> <li> Gas Pipeline</li> <li> Major Towns</li> </ul> |
|---|--|--|

### Bolivia to Brazil Gas Pipeline (Bolivian Portion)

Figure 4.11

### Physiography and Soils



Source: NOAA Earthquake Data Files

BOLIVIA TO BRAZIL GAS PIPELINE (BOLIVIAN PORTION)

# EPICENTER MAP OF EASTERN BOLIVIA

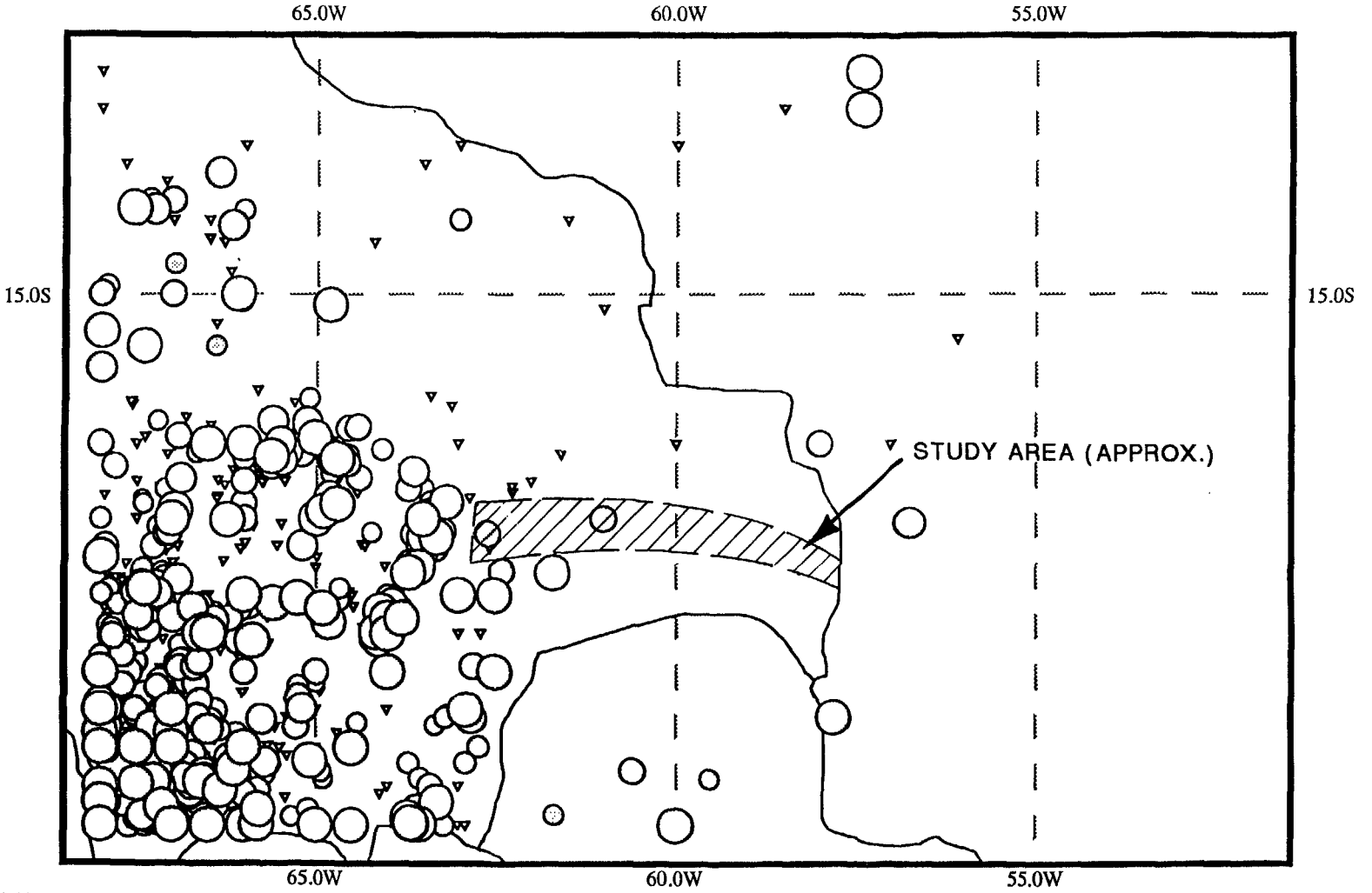

MAGNITUDES	
0.1 - 1.9	•
2.0 - 2.9	○
3.0 - 3.4	⊙
3.5 - 3.9	○
4.0 - 4.4	○
4.5 - 4.9	○
5.0 - 5.4	○
> 5.4	○

1214 Earthquakes Plotted  
NO INTENSITY OR MAGNITUDE ▼

INTENSITIES	
I-III	■
IV	■
V	■
VI	■
VII	■
VIII	■
IX	■
X-XII	■



FIGURE 4.12

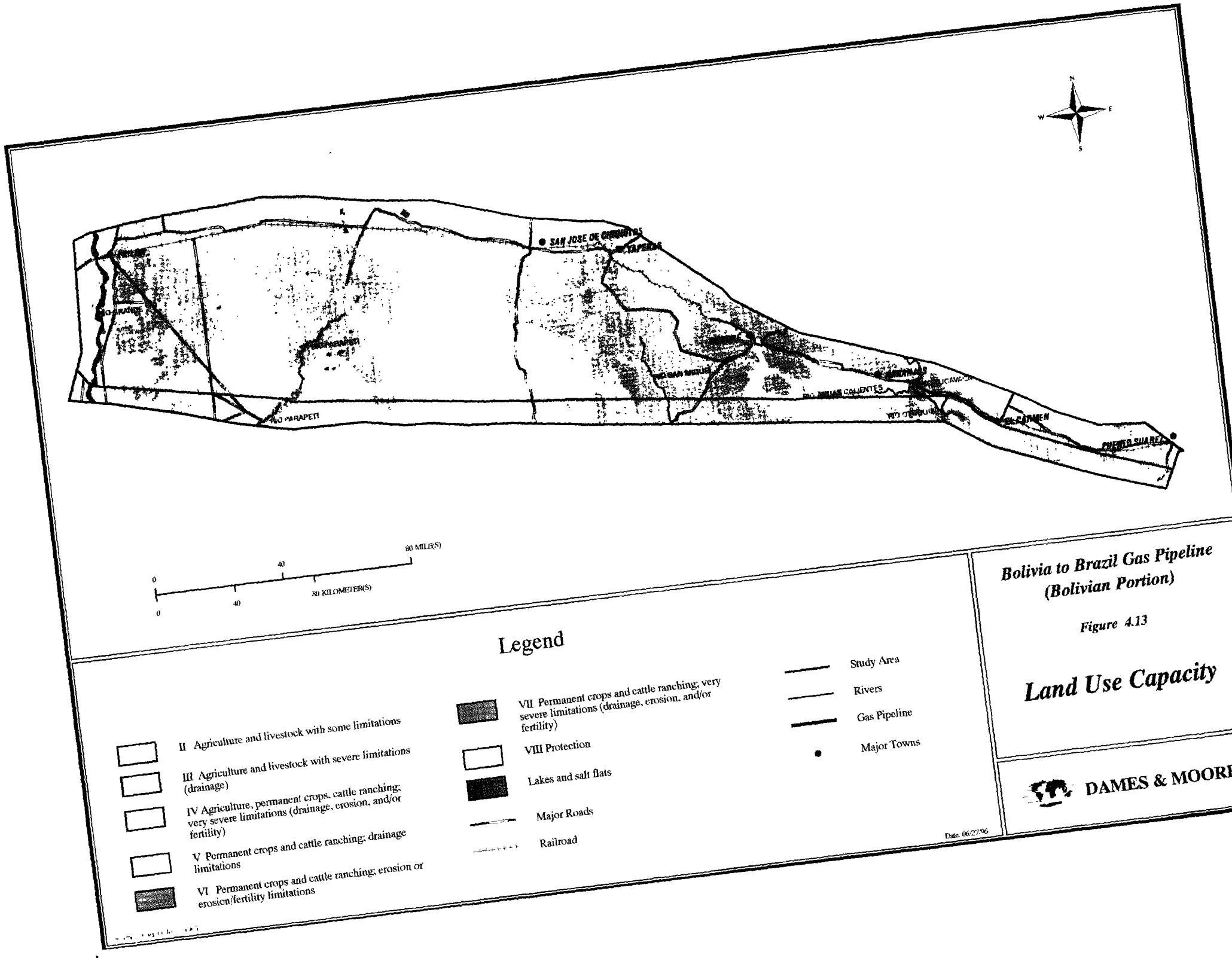

**Bolivia to Brazil Gas Pipeline  
(Bolivian Portion)**

Figure 4.13

**Land Use Capacity**



Date: 06/27/96

- II Agriculture and livestock with some limitations
- III Agriculture and livestock with severe limitations (drainage)
- IV Agriculture, permanent crops, cattle ranching; very severe limitations (drainage, erosion, and/or fertility)
- V Permanent crops and cattle ranching; drainage limitations
- VI Permanent crops and cattle ranching; erosion or erosion/fertility limitations

- Legend**
- VII Permanent crops and cattle ranching; very severe limitations (drainage, erosion, and/or fertility)
  - VIII Protection
  - Lakes and salt flats
  - Major Roads
  - Railroad

- Study Area
- Rivers
- Gas Pipeline
- Major Towns

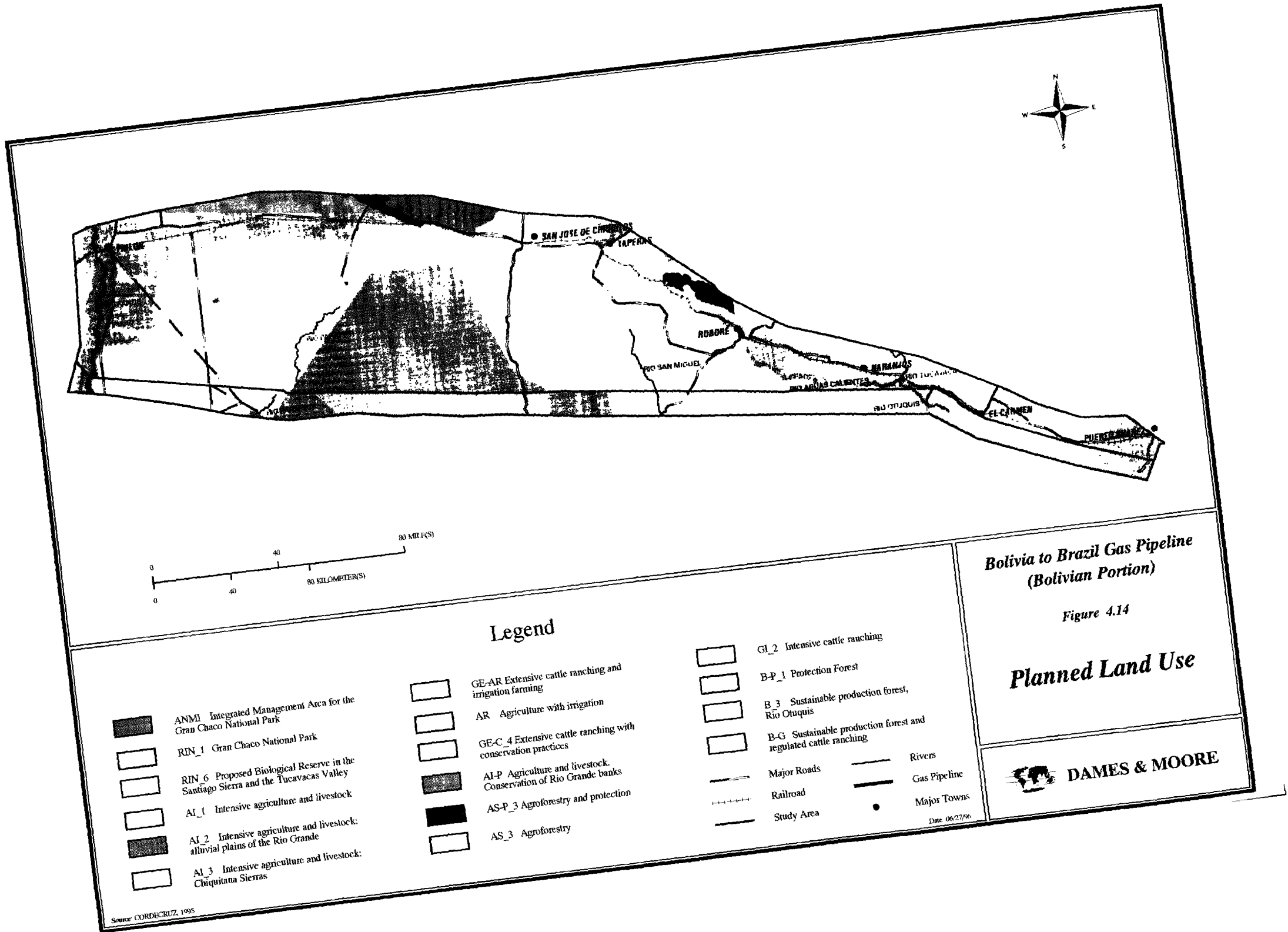

**Bolivia to Brazil Gas Pipeline  
(Bolivian Portion)**

Figure 4.14

**Planned Land Use**



Date: 06/27/96

Source: CORDERO, 1995

**Legend**

- ANMI Integrated Management Area for the Gran Chaco National Park
- RIN\_1 Gran Chaco National Park
- RIN\_6 Proposed Biological Reserve in the Santiago Sierra and the Tucavacas Valley
- AI\_1 Intensive agriculture and livestock
- AI\_2 Intensive agriculture and livestock: alluvial plains of the Rio Grande
- AI\_3 Intensive agriculture and livestock: Chiquitana Sierras

- GE-AR Extensive cattle ranching and irrigation farming
- AR Agriculture with irrigation
- GE-C\_4 Extensive cattle ranching with conservation practices
- AI-P Agriculture and livestock. Conservation of Rio Grande banks
- AS-P\_3 Agroforestry and protection
- AS\_3 Agroforestry







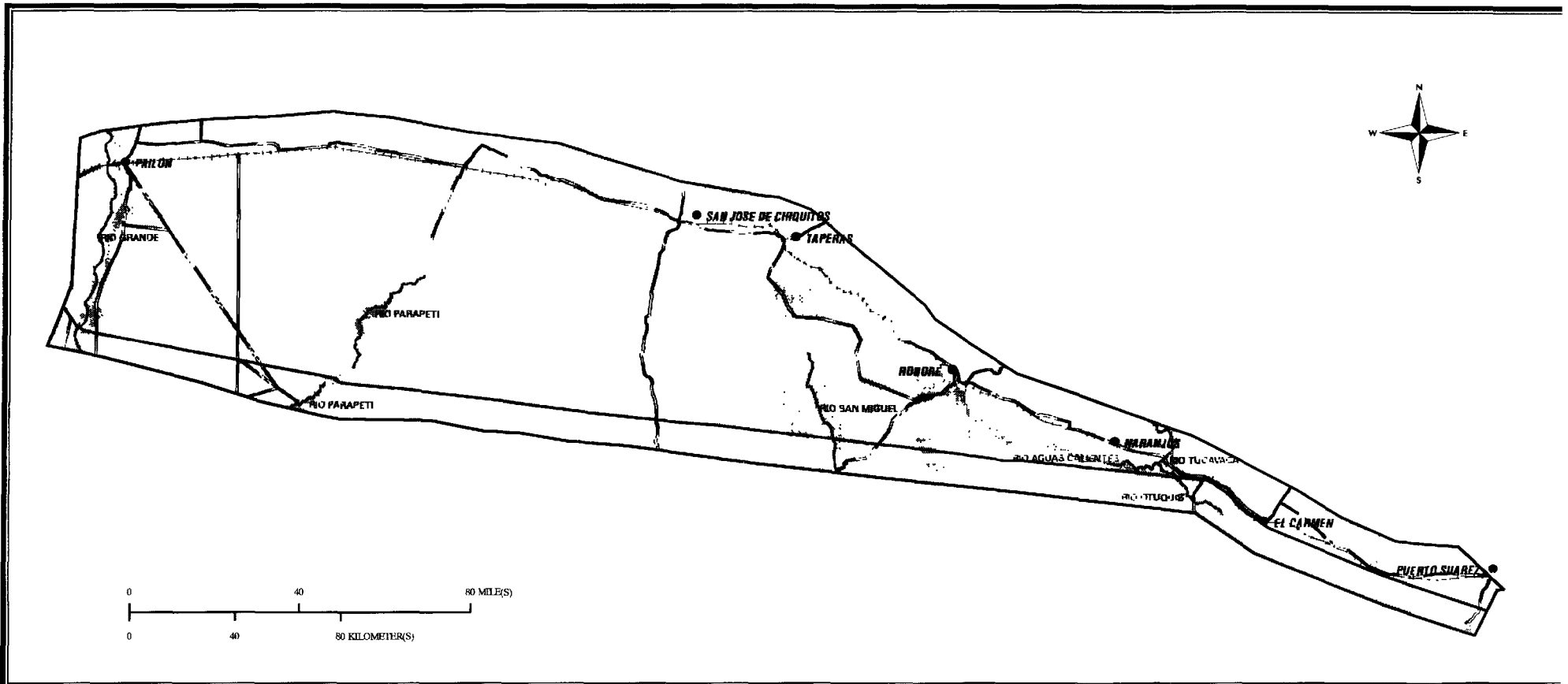









- GI\_2 Intensive cattle ranching
- B-P\_1 Protection Forest
- B\_3 Sustainable production forest, Rio Otquis
- B-G Sustainable production forest and regulated cattle ranching
- Major Roads
- Railroad
- Study Area
- Rivers
- Gas Pipeline
- Major Towns







### Legend

- |   |                                      |   |   |   |              |
|---|--------------------------------------|---|---|---|--------------|
|  | Very low forest                      |  | Marshes and swamps, including palm associations |  | Major Roads  |
|  | Medium forest                        |  | Low riparian forest                             |  | Railroad     |
|  | Very tall forest                     |  | Tall riparian forest                            |  | Study Area   |
|  | Secondary vegetation                 |  | Mountain forest                                 |  | Rivers       |
|  | Savannah (including wooded savannah) |  | Pastures  |  | Gas Pipeline |
|   |                                      |   |   |  | Major Towns  |

### Bolivia to Brazil Gas Pipeline (Bolivian Portion)

Figure 4.15

### Vegetation



DAMES & MOORE



BOLIVIA TO BRAZIL GAS PIPELINE (BOLIVIAN PORTION)  
PHYTOTOPOGRAPHIC PROFILE  
RIO GRANDE AREA

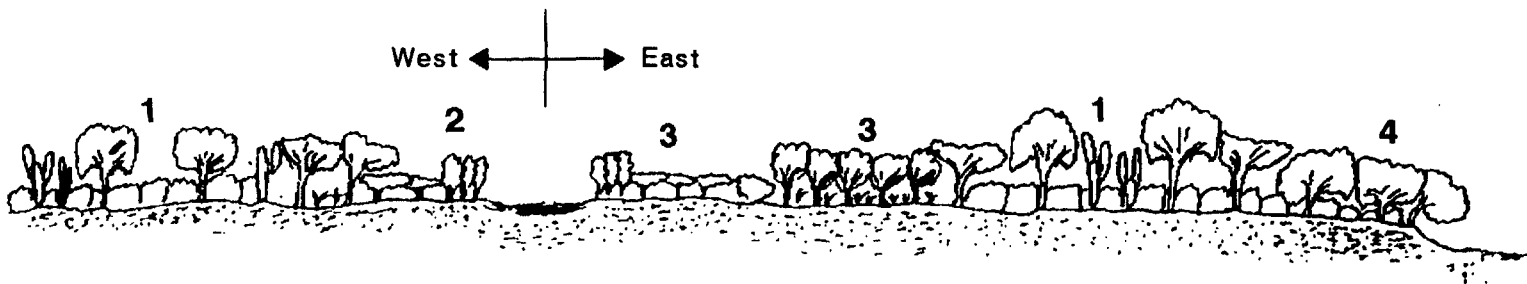

1. Humid chaqueño forest, characterized by *Aspidosperma pirifolium*.
2. Pioneer and riparian communities of *Acacia aroma* and *Tessaria integrifolia*.
3. Low forest in the floodplain, characterized by *Ruprechtia triflora* and *Tabebuia nodosa*.
4. Riparian tall forest characterized by *Guazuma ulmifolia*.

BOLIVIA TO BRAZIL GAS PIPELINE (BOLIVIAN PORTION)  
 PHYTOGEOGRAPHIC PROFILE.  
 BANADOS DE IZOZOG AND  
 ISLA VERDE AREAS

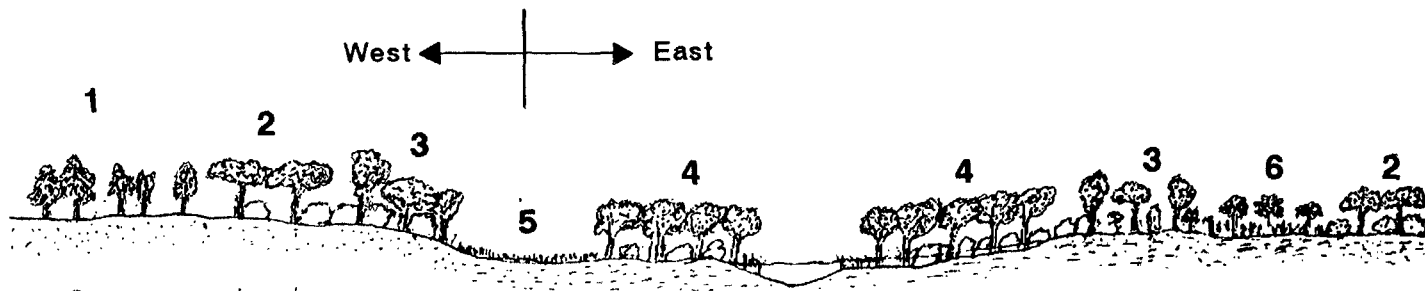

1. Dry chaqueño forest on sandy soils.
2. Mesic forest dominated by *Prosopis chilensis* on poorly drained soils.
3. Sub-humid chaqueño forest on occasionally flooded soils. Communities of *Calycophyllum multiflorum* and *Phyllostylon rhamnoides*.
4. Forests on flowing floodwaters. Communities of *Cathormion polyanthum*.
5. Crops on heavy soils.
6. Poneded depressional areas (most of the year). Palm associations dominated by *Copernicia alba*.

BOLIVIA TO BRAZIL GAS PIPELINE (BOLIVIAN PORTION)  
PHYTOGEOGRAPHIC PROFILE OF THE  
SAN JOSE DE CHIQUITOS TO  
THE PIPELINE AREA

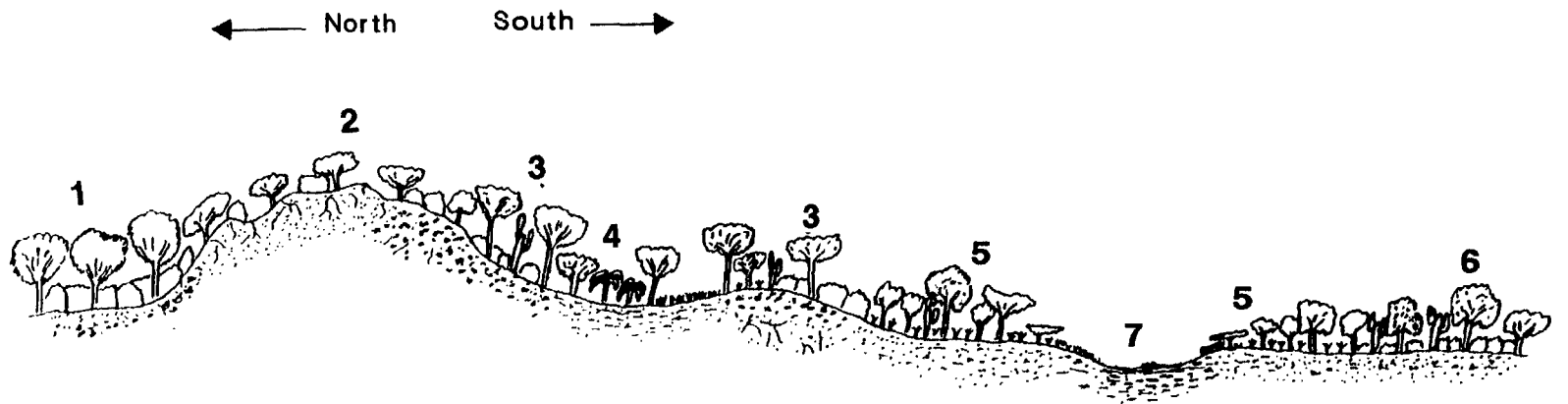

1. Tall sub-humid forest on the foothills. Cerrado Region.
2. Low sub-humid forest, highly disturbed. Cerrado Region.
3. Tall forest characterized by *Anadenanthera macrocarpa* and *Aspidosperma pirifolium*.
4. Humid forest. Palm associations of *Attalea phalerata*.
5. Sub-humid forest on foothills; characterized by *Prosopis chilensis* and *Diplokeleba floribunda*.
6. Dry chaqueño forest characterized by *Aspidosperma quebracho-blanco* and *Stetsonia corynei*.
7. Los Cirros creek.

BOLIVIA TO BRAZIL GAS PIPELINE (BOLIVIAN PORTION)  
PHYTOGEOGRAPHIC PROFILE  
PUERTO SUAREZ AREA

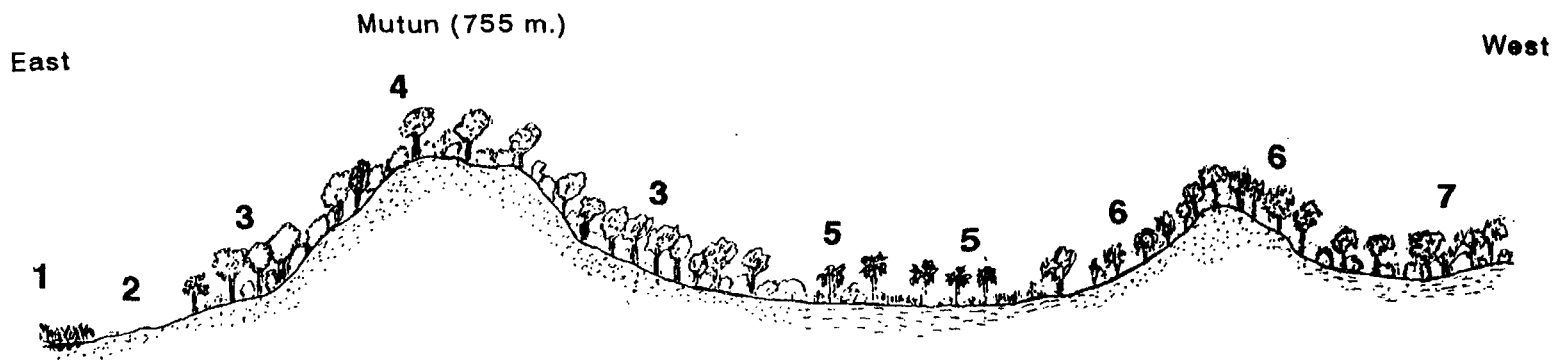

1. Grasslands dominated by *Hymarachne amplexicaulis*, Pantanal area.
2. Communities of floating plants dominated by *Victoria amazonica*.
3. Tall semideciduous forest of the Cerrado.
4. Open forest with cacti. Cerrado region.
5. Tacuaral floodplain. Associations of *Copernicia alba*.
6. Low semideciduous forest with cacti. Cerrado region.
7. Subhumid chaqueño forest.



**Dames & Moore**

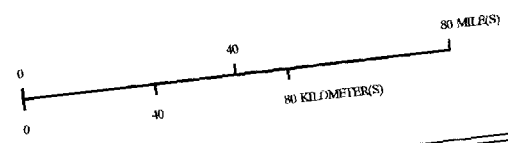
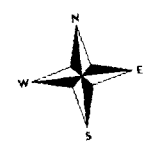
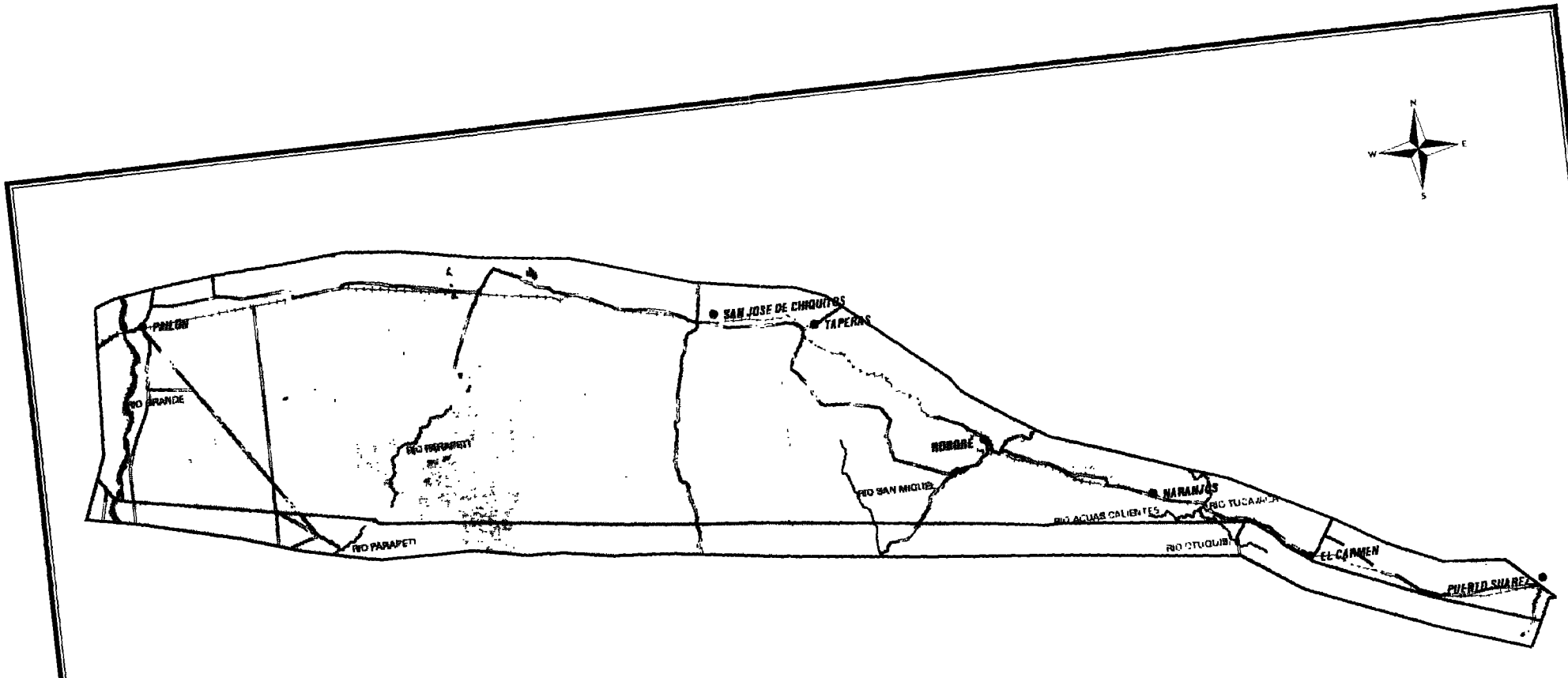

**Legend**

- I No forestry potential
- II Low forestry potential
- III Limited forestry potential
- IV Moderate forestry potential

- V High forestry potential
- VI Very high forestry potential
- Major Roads
- Railroad

- Study Area
- Rivers
- Gas Pipeline
- Major Towns

**Bolivia to Brazil Gas Pipeline  
(Bolivian Portion)**

Figure 4.17

**Forestry Potential**



Source: CORDECruz, 1995





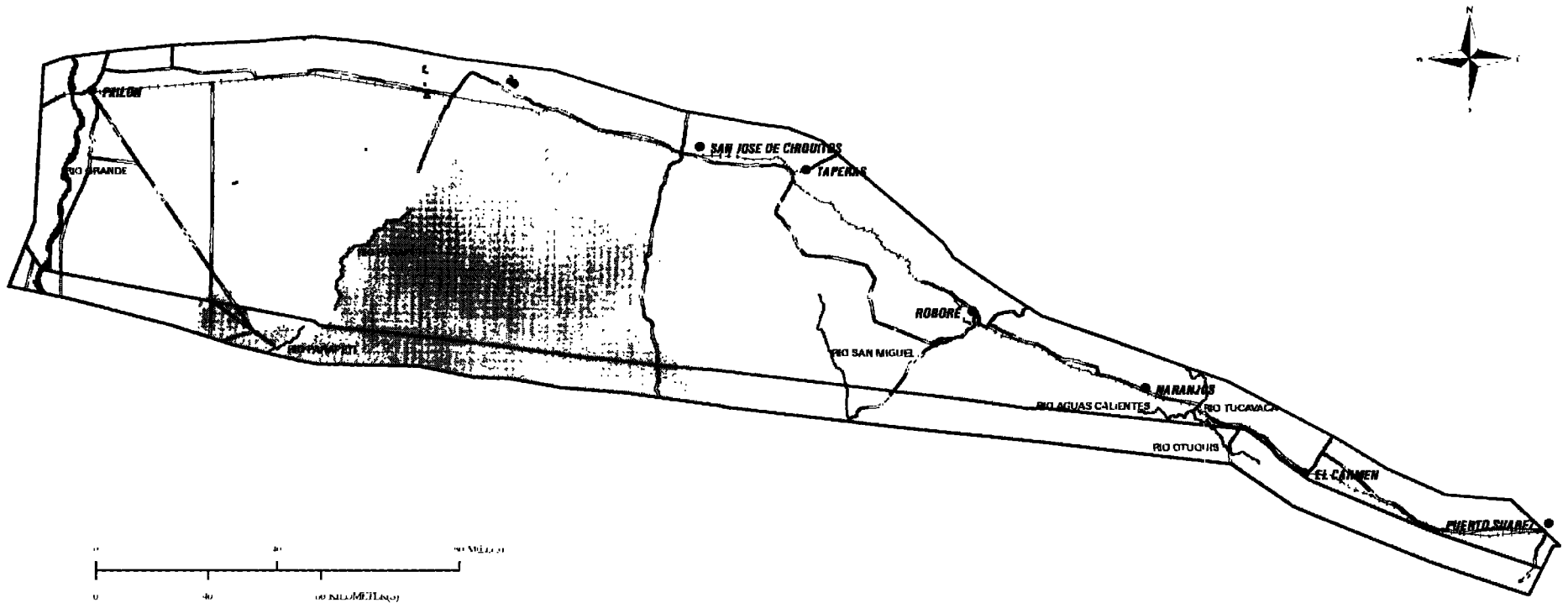

Date: 06/27/96





### Legend

-  Low Sensitivity
-  Medium Sensitivity
-  High Sensitivity

-  Major Roads
-  Railroad
-  Study Area
-  Rivers
-  Gas Pipeline
-  Major Towns

**Bolivia to Brazil Gas Pipeline  
(Bolivian Portion)**

Figure 4.18

### Environmental Sensitivity



**CHAPTER 5.0  
SOCIOECONOMIC BASELINE**

**TABLE OF CONTENTS**

5.1	GENERAL . . . . .	5 - 1
	5.1.1 Introduction . . . . .	5 - 1
	5.1.2 Geographic Setting . . . . .	5 - 1
	5.1.3 Socioeconomic Units . . . . .	5 - 3
5.2	PAILÓN-TRES CRUCES (UNIT I) . . . . .	5 - 4
	5.2.1 Land Use . . . . .	5 - 4
	5.2.2 Political and Social Organizations . . . . .	5 - 4
	5.2.3 Population . . . . .	5 - 5
	5.2.4 Health . . . . .	5 - 6
	5.2.5 Education . . . . .	5 - 6
	5.2.6 Cultural, Archeological, and Recreational Resources . . . . .	5 - 7
	5.2.7 Productive Systems . . . . .	5 - 7
	5.2.8 Employment . . . . .	5 - 8
	5.2.9 Infrastructure and Services . . . . .	5 - 9
5.3	SAN JOSE DE CHIQUITOS AREA (UNIT II) . . . . .	5 - 10
	5.3.1 Land Use . . . . .	5 - 10
	5.3.2 Political and Social Organizations . . . . .	5 - 10
	5.3.3 Population . . . . .	5 - 11
	5.3.4 Health . . . . .	5 - 13
	5.3.5 Education . . . . .	5 - 13
	5.3.6 Cultural, Archeological, and Recreational Resources . . . . .	5 - 13
	5.3.7 Production Systems . . . . .	5 - 14
	5.3.8 Employment . . . . .	5 - 16
	5.3.9 Infrastructure . . . . .	5 - 16
5.4	ROBORE (UNIT III) . . . . .	5 - 17
	5.4.1 Land Use . . . . .	5 - 17
	5.4.2 Political and Social Organizations . . . . .	5 - 17

**CHAPTER 5.0**  
**SOCIOECONOMIC BASELINE**

**TABLE OF CONTENTS**

5.4.3	Population . . . . .	5 - 18
5.4.4	Health . . . . .	5 - 19
5.4.5	Education . . . . .	5 - 19
5.4.6	Social, Cultural and Archeological Resources . . . . .	5 - 20
5.4.7	Production Systems . . . . .	5 - 21
5.4.8	Employment . . . . .	5 - 21
5.4.9	Infrastructure . . . . .	5 - 21
5.5	EL CARMEN (UNIT IV) . . . . .	5 - 22
5.5.1	Land Use . . . . .	5 - 22
5.5.2	Political and Social Organizations . . . . .	5 - 23
5.5.3	Population . . . . .	5 - 23
5.5.4	Health . . . . .	5 - 24
5.5.5	Education . . . . .	5 - 24
5.5.6	Cultural, Archeological and Recreational Resources . . . . .	5 - 24
5.5.7	Production Systems . . . . .	5 - 25
5.5.8	Employment . . . . .	5 - 26
5.5.9	Infrastructure . . . . .	5 - 26
5.6	PUERTO SUÁREZ/PUERTO QUIJARRO (UNIT V) . . . . .	5 - 26
5.6.1	Land Use . . . . .	5 - 26
5.6.2	Political and Social Organizations . . . . .	5 - 28
5.6.3	Population . . . . .	5 - 29
5.6.4	Health . . . . .	5 - 30
5.6.5	Education . . . . .	5 - 30
5.6.6	Social, Cultural and Archeological Resources . . . . .	5 - 31
5.6.7	Production Systems . . . . .	5 - 31
5.6.8	Employment . . . . .	5 - 32

**CHAPTER 5.0**  
**SOCIOECONOMIC BASELINE**

**TABLE OF CONTENTS**

5.6.9	Infrastructure and Services . . . . .	5 - 32
5.7	Indigenous Peoples . . . . .	5 - 34
5.7.1	Ayoreos . . . . .	5 - 35
5.7.2	Chiquitanos . . . . .	5 - 37
5.7.3	Izozeño Guaraní . . . . .	5 - 37

**CHAPTER 5.0**  
**SOCIOECONOMIC BASELINE**

**LIST OF FIGURES**

<u>FIGURE NO.</u>	<u>DESCRIPTION</u>
5.1	LOCATION OF SOCIOECONOMIC UNITS
5.2	CULTURAL AND ARCHAEOLOGICAL AREAS

## **5.0 SOCIOECONOMIC BASELINE**

### **5.1 GENERAL**

#### **5.1.1 Introduction**

The socioeconomic baseline of the study area was defined by characteristics and attributes of land uses, population, health, education; cultural, archeological and recreational resources; productive systems, employment, infrastructure, and the presence of indigenous peoples. The existing database created in the previous EIS completed by CUMAT was reviewed and documented to provide baseline information for use during this study.

The existing data were updated and supplemented with readily available information obtained from the 1992 National Census and the 1994-1995 Census of the Indigenous Peoples of Oriente, Chaco and the Amazon. In circumstances where the existing data were judged insufficient for EIS purposes, the socioeconomic data base was supplemented with information collected during field surveys.

The methodology used for the field work consisted of a combination of qualitative and quantitative data collection techniques such as rapid rural appraisal, community surveys, and formal and informal interviews which were completed in conjunction with the Public Consultation Program described in Chapter 8. The main objective of the field work was to gain a sound understanding of the socioeconomic conditions and use of ecological resources of the study area, and to assess areas which would be influenced directly and indirectly by the project.

#### **5.1.2 Geographic Setting**

The Bolivia to Brazil Gas Pipeline Project extends 557 km over Bolivian soil, and will be located entirely within the Department of Santa Cruz in the southeastern portion of Bolivia. Although the pipeline right-of-way is located within the Provinces of Cordillera and German Bush, the study area also includes the Province of Chiquitos where the main human settlements are located.

Encompassing 1,098,000 km<sup>2</sup>, Bolivia is South America's fifth largest country and has a population of approximately 7.2 million people. It is bounded by five countries: Peru, Brazil, Paraguay, Argentina, and Chile. Bolivia has the highest elevation of the Latin American countries, and is climatically, agroecologically, topographically, culturally, and ethnically, a very diverse country.

As of 1995, Bolivia's gross domestic product (GDP) was worth US\$ 5,601 million, or about US\$ 700 per capita, and the growth rate was 1.9 percent between 1984 and 1994. Average Inflation in the last five years was on the order of 10 percent. Total exports and investment in 1994 amounted to 17 percent and 15 percent of the GDP, respectively.

Administratively, Bolivia is a republic with legislative, executive, and judicial branches of government. The legislative and executive branches convene in La Paz, making this city the acting Capital of the country. The Supreme Court sits in Sucre, the legal Capital.

Bolivia is divided into nine *Departamentos* (Departments; equivalent to States). Each Department is divided into *Provincias* (Provinces) and each Province is divided in *Cantones* (Contras; equivalent to Counties) and Municipalities. The highest authority in each Department is the *Prefecto* (Prefect; equivalent to the Governor). Each Province has a *Subprefecto* (Subprefect) and each municipality is administered by a Mayor.

The Department of Santa Cruz is located in the eastern section of the Republic of Bolivia. It is bounded to the north by the Department of Beni, to the south by the Department of Chuquisaca and the Republic of Paraguay, to the east by the Republic of Brazil, and to the west by the Departments of Chuquisaca and Cochabamba.

According to the results of the 1992 Census, the total population of the Department of Santa Cruz was 1,364,389 inhabitants with an annual growth rate of 4.16 percent. The 1992 census also indicated that Santa Cruz is the Department with the second largest population in the country, after the Department of La Paz. This Department presents an annual urban growth rate of 6.15 percent and a much lower rural growth rate of only 0.82 percent.

Administratively, the study area corresponds to the Provinces of Chiquitos, Cordillera, and German Bush. According to the 1992 census, the total population of these three Provinces was 156,573. The project study area includes five of the 15 cantons of the Chiquitos and German Bush Provinces and one canton of the Cordillera Province. According to the 1992 census, the total population of these six cantons was approximately 44,758 inhabitants.

The urban centers within the study area include the towns of Pailón, San José de Chiquitos, Roboré, El Carmen, Puerto Suarez, and Puerto Quijarro. The 1992 census indicated a total of 41,101 inhabitants for the combined population of these six urban centers. Their combined projected population for 1996 is 48,335 inhabitants.

An additional community considered in the study is represented by the Capitanía del Alto y Bajo Izozog (CABI). The CABI community is settled outside and to the south of the limits of the area of direct impacts associated with the project. However, CABI has a direct relationship with the creation and administration of the Gran Chaco National Park and Integrated Management Areas. The Gran Chaco National Park is considered the most sensitive area within the study area, due to its protected status, large biological resources, indigenous populations, and biogeographic status. The project borders the northern boundary of the Park and the southern boundary of the Park's Integrated Management Area, for approximately 75 kilometers, and consequently, the CABI community will have an indirect interaction with the project.

### 5.1.3 Socioeconomic Units

The study area has been divided into six socioeconomic units for the purpose of this study. These units are summarized below:

- Pailón-Tres Cruces (Unit I)
- San José de Chiquitos (Unit II)
- Roboré (Unit III)
- El Carmen (Unit IV)
- Puerto Suarez/Puerto Quijarro (Unit V)



- Indigenous Peoples, CABI community (Unit VI)

The socioeconomic baseline characteristics of these six units are presented in the following sections. The relative location of each of these socioeconomic units is depicted in Figure 5.1.

## **5.2 PAILON-TRES CRUCES (UNIT I)**

### **5.2.1 Land Use**

The Pailón-Tres Cruces Unit (Unit I) is located in the western portion of the study area and forms part of the so-called “integrated sub-region” of the Department of Santa Cruz. This unit extends close to the border that divides the cantons of El Cerro, Motacusito and the Bañados de Izozog (Izozog Marshlands) in the southwest part of the Province of Chiquitos. The major population center in Unit I is Pailón.

The Pailón area is characterized by a strong presence of industrial and agroindustrial capital and large areas of foreign colonization and settlements, attracted mainly by the quality of the land in the region. The region also includes farmers and indigenous communities that are involved in small scale agricultural activities.

In recent years, the significant increase in soybean production has activated the regional economy, resulting in the development of a large service infrastructure such as roads, electricity, schools and potable water. However, there still are severe deficiencies in the services provided in the small communities of the region, especially in the areas of health and education.

### **5.2.2 Political and Social Organizations**

The principal governing authorities in the area are represented by the Pailon Mayor’s office and the Civic Committee. The principal law enforcement agency is the National Police.

There are 24 "Organizaciones Territoriales de Base" (Territorial Base Organizations OTBs) which represent the organization system defined by the recently enacted Law of Public Participation (Ley de Participación Popular). The OTBs in the region include two indigenous communities, 12 peasant communities, and 10 neighborhood councils (referred to as "juntas vecinales").

Additional institutions and organizations present in the region are an agrarian union; the electrical, water and telephone cooperatives; a savings and credit cooperative; and a mothers club (dedicated to goodwill work).

The religious sector is represented principally by the Catholic Church. However, the Evangelical Church also has a significant influence in the region.

### 5.2.3 Population

The 1992 Census data indicated that Pailón had a total population of 3,741 people, distributed as 52 percent male and 48 percent female. The "young" population (0 to 14 years of age) represented 46 percent, the "active" population (15 to 64 years of age) 52 percent, and the "senior" population (65 years and over) 2 percent. Consequently, the Pailón population is considered young, as almost 50 percent of the total population is below the age of 14.

The general structure of the population in Pailón is presented in the following table:

Gender	Total Number of Inhabitants	Number of Inhabitants between 0-14 years of age	Number of Inhabitants between 15-64 years of age	Number of Inhabitants 65 years of age and over	Number of Inhabitants with age not specified
Men	1947	848	1046	50	3
Women	1794	880	872	40	2
Total	3741	1728	1918	90	5

The growth rate of the population is 4.16 percent according to the 1992 census. Based on this growth rate, the projected population of Pailón for 1996 is about 4,400 inhabitants. The predominant family size ranges from four to eight children per family, with an average of five children.

The mortality rate in the region is reported to be 6.9 percent. This high rate is the result of significant infant mortality related to poor living conditions, deficient health care and education services, and diseases such as dysentery, malaria, etc.

The area between Pailón and Los Troncos is considered to be one of the most important sectors within the Department of Santa Cruz for foreign migration, and to a lesser degree for indigenous migration (such as the Ayoreos). The predominant foreign settlements established in this region are Mennonites, Finns, Canadians, and Hindus.

In general, religious beliefs constitute the foundations for organizational patterns and life within the foreign settlements. These settlements have been reluctant to assimilate or engage in external social contact with local groups or individuals in the region. From this perspective, there is basically no Mennonite participation in the organizational, cultural and political life of the region.

#### **5.2.4 Health**

Pailón includes one small hospital, four first aid posts and one health center. The medical work force includes one doctor and two nurses assisted by several midwives located throughout the region. The Mennonite communities have two health centers serving exclusively the needs of their own inhabitants. The most common diseases in the region are dysentery, malaria, lung infections, parasites, bronchopneumonia, measles, and tuberculosis.

### 5.2.5 Education

There are currently two pre-schools, two primary schools, and one high school providing basic education to the inhabitants of the region. Due to the lack of technical schools or universities in the region, the majority of the population does not have access to higher education. The Mennonite colonies have implemented their own educational system based mainly on their cultural and religious beliefs. Basic education in the region is provided mainly by teachers who graduated from the local schools and attended a teacher's school in one of the main Bolivian cities.

### 5.2.6 Cultural, Archeological, and Recreational Resources

A review of the "Ethnic, Territorial, and Archeological Map of Bolivia" indicated no cultural or archeological resources in Pailón and the area located between the railroad and the pipeline right-of-way. However, a literature research of cultural and archeological resources within the area of influence of the project identified the following site in the general vicinity of the Pailón-Tres Cruces Unit:

- **Pailón Site.-** A archeological exploratory site exists about one km to the south of Pailón. This site has been named "Proyecto Grigotá" and includes a total of five exploratory pits located 20 to 100 meters from each other. The pits are four meters square and three meters in depth. To date, the exploratory pits have encountered ceramic remains which are believed to belong to the period comprised between the years 800 and 1,000. The Pailón archeological exploration started in 1994 and is planned to be completed in September 1996. This effort is being developed as a joined effort between the National Institutes of Archeology of Bolivia and Germany.

The relative location of the Pailón site within the area of influence of the project is shown in Figure 5.2.

Recreational spaces in the area include the town main square, several sports complexes including one soccer field, two discotheques, and a horse track.

### 5.2.7 Productive Systems

The economy of Pailón is based principally on agricultural activities implemented by small, medium and large producers who cultivate over 100,000 hectares of land. Key landowners and foreign communities currently own and control the majority of the agricultural, livestock and agroindustrial production in the zone. However, approximately 25 percent of the agricultural areas are owned and worked by farming families. Of the 630 families settled in this socioeconomic unit, 95 percent are involved in agriculture.

Irrespective of agroecological and local differences, most inhabitants are subsistence farmers who produce the bulk of their own food requirements as well as some cash crops. Moreover, a certain portion of the food crops grown mainly for household consumption are almost invariably marketed. Thus, in the peasant farmer's mind, there is not a strict distinction between what is eaten and what is sold. In addition to assuring the household a year-round supply of consumable goods, mixed cropping, a traditional practice in all the areas that were surveyed, reduces the danger of soil erosion caused by land clearing.

Soybean production accounts for over 50 percent of the total production in the region. Crop production also includes sugar cane, corn, sorghum, and rice. Soybeans are sold directly to oil factories, and corn and sorghum are shipped to different regions within and outside the Department of Santa Cruz. Other agricultural products produced in the region are sold locally, around the country and overseas. The revenues generated by these transactions are reinvested into the local economy.

The main development projects in the region over the last fifteen years have included the construction of the Santa Cruz-Trinidad road, the improvement of the Pailón-San José de Chiquitos road, and the expansion of the Pailón potable water supply system and waste water treatment system. These projects have had a ripple economic effect, resulting in a large number of benefits which have occurred as a result. For instance, the implementation of the projects has resulted in the development of additional lodging, restaurants, gasoline stations, local markets, a terminal for cargo transport, and other industries in the area.

### **5.2.8 Employment**

The majority of the population in Pailón is employed by large scale agroindustrial farms in activities that include land preparation, crop harvesting and collection. Small-scale commerce and petty trade are also essential ingredients of household income generation. The latter activities represent one of the most important sources of income for women.

The average peasant family dedicates up to four of their members to farming activities. People who are unable to cultivate large sections of land work on the average of 60 days per calendar year as day workers, farming the lands of larger landowners in the region. Within this local economy, there are no specific activities which have been designated to be performed by females only, they participate in all agricultural activities. However, women dedicate less time to these tasks than their male counterparts due to domestic responsibilities.

### **5.2.9 Infrastructure and Services**

The main roadway infrastructure in the area includes the paved two-way roadway that connects Pailón to Santa Cruz, the unpaved road that connects Pailón to Puerto Suárez, and an unpaved road that extends to the south towards the pipeline right-of-way. Transportation infrastructure in Pailón also includes the Santa Cruz-Corumbá railroad system which provides daily service to the city of Santa Cruz, and service to Puerto Quijarro and Puerto Aguirre three days a week.

The 1992 Census recorded 738 houses in the Pailón area. These houses included 720 single family homes and 18 community homes. Houses located within the city boundaries are constructed of cement and bricks, and were observed to be generally in good condition. In contrast, houses located on the outskirts of Pailón are constructed of mud, branches and straw, and were observed to be generally in poor condition.

Potable drinking water and electricity are supplied to approximately 60 percent of the population. Each house has its own septic tank for sanitary waste water discharge since the region lacks a public sewer system. Telephone service is provided to only 10 percent of the houses. Long

distance telephone service is provided by the Empresa Nacional de Teléfonos-ENTEL (National Telecommunication Company).

Local and regional transportation is provided by bus and taxi service cooperatives (Cooperativa de Transporte Mixto). Traffic during the harvest season on the Santa Cruz-Puerto Suárez highway increases significantly, reaching up to 2,000 vehicles per month.

### **5.3 SAN JOSE DE CHIQUITOS AREA (UNIT II)**

#### **5.3.1 Land Use**

The San José de Chiquitos Unit (Unit II) is located approximately 266 km east of the city of Santa Cruz and is bounded to the west by El Tinto and to the east by the Ayoreode community of Tobite. The area of influence of this region was defined by the CIAT/PRODESA Program (Centro de Investigación Agrícola Tropical/Programa de Desarrollo de San José de Chiquitos) in 1990. The major population center in Unit II is San José de Chiquitos.

The economy of the region is supported mostly by cattle raising carried out by independent ranching families, and to a lesser degree by small to medium-scale agriculture which supplies mainly internal markets. In general, revenues generated locally are reinvested in the local economy.

San José de Chiquitos is an important historical site within the region and has become the link between large agricultural production areas within the Department of Santa Cruz. This capacity has required the creation of a regional commercial economy throughout the entire Province of Chiquitanía, which has been supported mainly by the Santa Cruz-Puerto Suárez railroad. The construction of several access roads for petroleum exploration and exploitation has also facilitated the commercialization of the main livestock and agricultural products in the region.

### 5.3.2 Political and Social Organizations

The official entities located in the region are: the Sub-Prefecture, Mayor's Office, Civil Register (Registro Civil), Internal Revenue Service (la Renta Interna), and the Court of Instruction (Juzgado de Instrucción). There are 33 OTBs. The OTBs in the region include 23 peasant communities and 10 neighborhood councils.

The region is served by several cooperatives such as the savings and loans, water and energy supply, communications and transportation, and by three unions representing different working sectors in the region: urban teachers, railroad workers, and masons.

Other institutions present in the region include the BIDESSA Bank, ENTEL, the Cattle Raising Federation, the National Association of Soybean Producers, the Forest Development Center, and a Mothers Club (dedicated to goodwill work). Non Governmental Organizations (NGOs) present in the zone are:

- CARITAS serving the agricultural and cattle raising sector;
- CIAT supporting investigations in the agricultural and cattle raising fields; and
- CCH-SUR assisting the health sector.

The majority of the population in the region is Catholic, however, there is an important influence from the Evangelic and Mormon Churches.

### 5.3.3 Population

The 1992 Census indicated that the total population in San José de Chiquitos was 8,483 inhabitants, distributed as 50 percent male and 50 percent female. The "young" population (0 to 14 years of age) represented 46 percent, the "active" population (15 to 64 years of age) 50 percent, and the "senior" population (65 years and over) 4 percent. Consequently, the population in the region is considered young, as 46 percent of the total population is below the age of 14.



The general structure of the population in San José de Chiquitos is presented in the following table:

Gender	Total Number of Inhabitants	Number of Inhabitants between 0-14 years of age	Number of Inhabitants between 15-64 years of age	Number of Inhabitants 65 years of age and over	Number of Inhabitants with age not specified
Men	4257	1956	2162	137	2
Women	4226	1971	2125	128	2
Total	8483	3927	4287	265	4

The growth rate of the population is 4.16% according to the 1992 census. Based on this growth rate, the projected population of San José de Chiquitos for 1996 is about 9,976 inhabitants. The family size ranges from four to eight children per family, with an average of five children.

With regard to the mortality rate, it was reported that there is a high rate of infant mortality as a result of poor living conditions, deficient health care and education services, and diseases such as dysentery and malaria.

Several large national settlements have developed along the railroad line in the central Chiquitana zone for the implementation of small scale agriculture. These settlements became legal communities following the enactment of the Ley de Reforma Agraria (Land Use Law).

The region has also been considered important for foreign migration due to the presence of suitable soil to develop agricultural and livestock activities, and the railroad. For instance, a Mennonite colony called Nueva Esperanza (New Hope) was established in the early 1970s, and since then it has been involved in producing annual crops and raising livestock using intensive production systems.

#### 5.3.4 Health

San José de Chiquitos houses two hospitals and one first aid station. These hospitals are owned by the Foyannini Health Secretary and ENFE (Railroad National Company). The current physical condition of the hospital, the station, and their medical equipment was reported to be deficient. The most common diseases in the region are dysentery, malaria, lung infections, parasites, bronchopneumonia, measles, and tuberculosis.

#### 5.3.5 Education

There are currently two pre-schools, seven elementary schools, and two secondary schools providing basic education to the inhabitants of the region. Basic education is provided mainly by teachers who graduated from the local schools and attended a teacher's school in one of the main Bolivian cities. There is a polytechnic institute providing higher education. The institute, which has an educational trade agreement with the René Moreno University in the city of Santa Cruz, offers two technical careers: agronomy and veterinary medicine.

The new educational tendency in the region is to promote community production, reflecting over the agricultural situation, and finding solutions to problems through the effort and participation of the entire community.

#### 5.3.6 Cultural, Archeological, and Recreational Resources

A review of the "Ethnic, Territorial, and Archeological Map of Bolivia" indicated no cultural or archeological resources in San José de Chiquitos and the area located between the railroad and the pipeline right-of-way. However, a literature research of cultural and archeological resources within the area of influence of the project identified the following sites in the general vicinity of the San José de Chiquitos Unit:

- **San José Cathedral.**- The most important historical sites in the region are the Jesuits Cathedral and the Santa Cruz la Vieja National Historic Park both of which are located in

San José de Chiquitos. The San José Cathedral was completed in 1754 and represents one of the oldest Jesuit churches in America.

- **Santa Cruz la Vieja National Park.**- The Santa Cruz la Vieja park was established as a National Historic Site by Presidential Decree No. 22140 on February 22, 1989. The park represents the site of the first settlement of the city of Santa Cruz which was founded on February 26, 1561. The old Santa Cruz ruins are believed to be underneath a series of promontories which extend across the forested area that constitutes the park. A regional movement has started to promote the development of the Santa Cruz La Vieja Historic Park as a major historic and tourism center. This program is receiving extensive participation by the local social agents of development such as the Civic Committee, Peasant Union, Ranchers Association, Center for Forest Development, etc.
- **Quimome Site.**- The Quimome site, explored by Pfa in 1986, is located about 55 km west of San José de Chiquitos. Exploratory pits made at this site encountered a human skeleton surrounded by ceramic remains.

The relative locations of these sites within the area of influence of the project are shown in Figure 5.2.

Recreational facilities include the town main square, several sport complexes including soccer fields, cinema, discotheque and karaoke. In addition, there is a private health resort located in the Shuto park.

### 5.3.7 Production Systems

As previously indicated, the economy of the region is supported mostly by cattle raising carried out by independent ranching families, and to a lesser degree by small to medium-scale agriculture. This economy supplies internal markets, and revenues generated during commercial transactions are reinvested in the local economy.

There are currently four types of ranching according to a CIAT criteria: subsistence ranching, complementary ranching, capitalized ranching, and farmer ranching.

- In subsistence ranching the size of the herd (15-50 head) is insufficient to satisfy basic family needs, so income must be complemented through small scale agriculture and occasional hunting. Commonly grown agricultural crops are corn, rice, and cassava in one to two hectare lots. In addition to cattle, other animals are also raised including chickens, turkeys, pigs, and horses.
- Complementary ranching is performed at approximately 90 ranches in the region and is considered as the second most important in terms of herd size (30-250 head). The size of the ranches ranges from 1,500 to 3,000 ha.
- Capitalized ranching involves herds larger than 250 head. This type of ranching is different from the ones previously described, because it generates levels of revenue such that it allows ranching families to live exclusively from this income. It is estimated that only 10 ranchers carry out capitalized ranching in the region. This production system utilizes a land area of at least 3,000 ha.
- Farmer ranching is practiced by Mennonite communities in ranches that have relatively large amounts of land (50 to 150 ha per ranch). Approximately 200 ranches in the region perform farmer ranching. These ranches also produce annual crops, such as cereals and soybeans. About 10 to 30 head of milk cows complement their agricultural activities. In addition, these ranches are equipped with high technical capacity which allows them to obtain increased production levels from their purebred stock.

Most inhabitants in the region are subsistence farmers who produce the bulk of their food requirements as well as some cash crops. The farmers, with the technical support from PRODESA, are currently cultivating crops such as soybeans, peanuts, cayu, rice, corn, cassava, beans, sweet potatoes, cherimoye, citrus fruits, and tobacco, which are then sold in markets in San José de Chiquitos and Santa Cruz. Most farmers harvest lots ranging from one to three hectares.

The main private industrial and commercial institutions present in the region are the Industria Minera La Rosa (La Rosa Mining Complex), and Aserraderos Surutu and Suto (Surutu and Suto Sawmills).

### **5.3.8 Employment**

The urban population is mostly employed by the different government institutions present in this unit. Workers from the peasant communities are employed as salaried labor for maintenance activities on the railroad or work as bricklayers in San José de Chiquitos. The majority of the cattle raisers live in San José de Chiquitos, where they generally have other activities such as working as government employees, business, and others.

### **5.3.9 Infrastructure and Services**

The main roadway infrastructure in the area includes the unpaved road that connects Santa Cruz to Puerto Suárez. However, transportation via this road is very limited due to the unreliable and poor physical conditions. In general, the road is used mainly during dry weather conditions. Transportation infrastructure in San José de Chiquitos also includes the Santa Cruz-Puerto Suárez railroad which provides daily service to the city of Santa Cruz, and service to Puerto Quijarro and Puerto Aguirre three days a week.

The 1992 Census recorded 1,592 houses in the San José de Chiquitos area. These houses included 1,578 single family homes and 14 community homes. The majority of the houses are constructed of sun-dried bricks.

Potable water and electricity are supplied to approximately 60 percent of the population. Electricity is available only 20 hours per day. Each house has its own septic tank for sanitary wastewater discharge since the region lacks a public sewer system.

A telecommunications system composed of 214 telephone lines and two radio communication stations currently serves the region. Long distance telephone service is provided by ENTEL and

a microwave booster station located approximately 15 kilometers from San José de Chiquitos. This station has been in operation since 1989.

## **5.4 ROBORE (UNIT III)**

### **5.4.1 Land Use**

The Roboré Unit (Unit III) is located approximately 400 km east of the city of Santa Cruz. Its borders extend from Tobite in the west to Santa Ana in the east. The major population center in the Unit is the town of Roboré.

The production economy of the region is based principally on livestock raising and small scale agricultural activities. Livestock raising is conducted by key land owners on approximately 110 ranches, located in the southern part of the region. It is estimated that these ranches raise about 66 percent of the region's 25,000 head of cattle. Livestock is raised to a lesser degree, on about 235 peasant farms. The peasant communities have approximately 235 family farms with herds ranging from 1 to 50 head of cattle. The majority of the cattle raised in the region are mixed and native breeds.

Other land uses in the region include the production of about 300 cubic feet of lumber per month from the region's forestry areas for the carpentry industry and the railroad (ties for the rail line).

### **5.4.2 Political and Social Organizations**

The official entities located in the region are the Mayor's Office, Civic Committee, Agrarian Reform Office, Assistant National Treasurer, and Comptroller's Office. An Army and Air Force Base with approximately 1,000 military personnel is also located in Roboré.

There are 39 OTBs, which include 2 indigenous communities, 20 peasant communities and 17 neighborhood councils.

Other institutions present in the region include the BIDES A Bank, two savings and loan cooperatives, an urban and a rural teacher's association, ENTEL a ranchers federation, a peasants federation, railroad union, hunting and fishing clubs, and the Bolivian Red Cross.

The majority of the population in the region is Catholic. However, there is an important influence from the Evangelical Church.

### 5.4.3 Population

The 1992 Census data indicated that the total population in Roboré was 10,360 inhabitants distributed as 50.2 percent males and 49.8 percent females. The "young" population (0 to 14 years of age) represented 44 percent, the "active" population (15 to 64 years of age) 53 percent, and the "senior" population (65 years and over) 3 percent. Consequently, the Roboré population is considered young, as 44 percent of the total population is below the age of 14. The general structure of the population in Roboré is presented in the following table:

Gender	Total Number of Inhabitants	Number of Inhabitants between 0-14 years of age	Number of Inhabitants between 15-64 years of age	Number of Inhabitants 65 years of age and over	Number of Inhabitants with age not specified
Men	5202	2245	2779	178	0
Women	5158	2295	2673	190	0
Total	10360	4540	5452	368	0

As with the previous units, the growth rate of the population in Roboré is 4.16% according to the 1992 census. Based on this growth rate, the projected population of Roboré for 1996 is about 12,184 inhabitants. The family size ranges from four to eight children per family, with an average of five children.

With regard to the mortality rate, it was reported that there is a high rate of infant mortality as a result of poor living conditions, deficient health care and education services, and diseases such as diarrhea and malaria.

#### **5.4.4 Health**

Roboré and Chochis currently house three hospitals and five first aid posts. The hospitals are owned by Caja Ferro, SNSP and Cosmil. The medical force includes 11 doctors (among them a surgeon, a pediatrician and an internal medicine specialist) assisted by several midwives located throughout the region.

The most common diseases in the region are dysentery, malaria, lung infections, parasites, bronchopneumonia, measles and tuberculosis.

#### **5.4.5 Education**

There are currently two public and three private secondary schools providing basic education to the inhabitants of the region. Private schools are "schools by agreement," subsidized between the State and the religious community with funds from Spain. Basic education is provided mainly by teachers who graduated from the local schools and attended a teacher's school in one of the main Bolivian cities.

In addition to these schools, there is a school for secretaries, a boarding school for orphans, and a technical institute. The Instituto Boliviano de Aprendizaje offers careers in the fields of mechanics, carpentry, electricity, knitting and cooking. The region also has an agreement with the University René Moreno of Santa Cruz which offers technical careers in agronomy and civil construction.

It is estimated that about 22 percent of the community does not have access to schools (children must travel to other towns for school), 15 percent have secondary education, and 85 percent only



have middle school. The student population in the region amounts to 6,830 students. The educational system employs approximately 250 teachers and one hundred administrative personnel.

#### **5.4.6 Social, Cultural and Archeological Resources**

A review of the "Ethnic, Territorial, and Archeological Map of Bolivia" indicated no cultural or archeological resources in Roboré and the area located between the railroad and the pipeline right-of-way. However, a literature research of cultural and archeological resources within the area of influence of the project identified the following sites in the general vicinity of the Roboré Unit:

- **Roboré Site 1.-** This site is located along the Santa Cruz-Corumbá railroad between the towns of Limoncito and San Miguel. Exploratory pits made at this site encountered ceramic remains (Riester, 1981).
- **Roboré Site 2.-** This site is located along the same railroad approximately 4 km towards San José de Chiquitos. The site presents animal paintings in red which were painted directly on the bedrock (Riester, 1981).
- **Santiago Site.-** This site is located approximately 4 km northwest of Roboré and is an old Jesuits settlement. The site presents paintings of humans, animals and a variety of geometric figures (Riester, 1981).

The relative locations of these sites within the area of influence of the project are shown in Figure 5.2.

Recreational facilities in the area include the town squares, several sports complexes including one soccer field, two libraries, four theaters, four recreational resorts with swimming pools, several discotheques and karaokes.

#### **5.4.7 Production Systems**

Tertiary activities, such as commercialization, prevail over the production activities of agriculture and livestock raising. The population is involved principally in the importation and distribution of goods and agricultural and livestock products. As a result, an intense commercial network has been created in the region that depends on the services provided by ENFE (Railroad National Company) and State institutions established in the area.

The productive economy also includes livestock raising and small scale agricultural activities. Agriculture is carried out by subsistence farming families who produce the bulk of their food requirements as well as some cash crops on 1.7 hectare lots per family on the average. The agricultural production system implemented by these families is rudimentary, involving the "slash and burn" method.

#### **5.4.8 Employment**

The majority of the population in Roboré is employed by the commerce establishments, cattle ranches, the railroad company, and government institutions present in the region. Petty trade activities are of vital importance for the survival of rural and urban families. The latter activities represent one of the most important sources of income for women.

In addition to conducting agricultural activities, the members of the peasant families in the region are hired as servants for households in Roboré and cattle ranches throughout the region. Many others work as maintenance laborers in the railroad or as bricklayers in local brick factories.

#### **5.4.9 Infrastructure**

The main roadway infrastructure in the area includes the unpaved road that connects Santa Cruz to Puerto Suárez. As previously indicated, transportation on this road is very limited due to the unreliable and poor physical conditions. In general, the road is used mainly during dry weather conditions. Transportation infrastructure in Roboré also includes the Santa Cruz-Puerto Suárez

railroad which provides daily service to the city of Santa Cruz, and service to Puerto Quijarro and Puerto Aguirre three days a week.

The 1992 Census recorded 2,029 houses in the Roboré area, including 2,008 single family homes and 21 community homes. Houses located within the city boundaries are constructed of cement and bricks, and were observed to be generally in good condition. In contrast, houses located on the outskirts of Roboré are constructed of mud, branches, and straw, and were observed to be generally in poor condition.

Potable water and electricity service are supplied to less than 50 percent of the households in the region. Electricity is not available on a 24-hour basis. Telephone service is provided to only 10 percent of the houses. Long distance telephone service is provided by ENTEL. Each house has its own septic tank for sanitary wastewater discharge since the region lacks a public sewer system.

## **5.5 EL CARMEN (UNIT IV)**

### **5.5.1 Land Use**

The El Carmen Unit (Unit IV) is located in the eastern portion of the study area and is bounded to the west by the town of Santa Ana, to the east by the town of Yacuses, to the north by Angel Sandoval Province (which is located just north of the railroad), and to the south by the Bañados de Otuquis (Otuquis Marshes). The major population center in the Unit is the town of El Carmen, a small town that, due to legal problems, has not yet defined its political status.

The region is characterized by a strong presence of logging concessions and agricultural activities conducted by subsistence farmers. Crop harvesting includes mainly citric fruits such as lemons, oranges, and grapefruit. Livestock raising is also conducted in the region, although to a much lesser degree.

### 5.5.2 Political and Social Organizations

The official entities located in the region are: Municipal Office ("Corregidor"), Mayor's Office and Civic Committee. There are eight OTBs, represented by five peasant communities and three neighborhood councils.

Other institutions present in the region include a savings and loan corporation, a water and electricity cooperative, a peasants union, and a Mother's Club. The religious sector is represented principally by the Catholic Church.

### 5.5.3 Population

The 1992 Census data indicated that the total population in El Carmen was 2,330 inhabitants distributed as 51.4 percent males and 48.6 percent females. The "young" population (0 to 14 years of age) represented 49 percent, the "active" population (15 to 64 years of age) 47 percent, and the "senior" population (65 years and over) 4 percent. Consequently, the El Carmen population is considered young, as 49 percent of the total population is below the age of 14. The general structure of the population in El Carmen is presented in the following table:

Gender	Total Number of Inhabitants	Number of Inhabitants between 0-14 years of age	Number of Inhabitants between 15-64 years of age	Number of Inhabitants 65 years of age and over	Number of Inhabitants with age not specified
Men	1198	603	550	45	0
Women	1132	545	546	41	0
Total	2330	1148	1096	86	0

As with the previous units, the growth rate of the population is 4.16 percent according to the 1992 census. Based on this growth rate, the projected population of El Carmen for 1996 is about 2,739

inhabitants. The family size ranges from four to eight children per family, with an average of five children.

The overall mortality rate in the region is reported to be 11% percent, the highest of all the Units in the study area. This high rate is the result of poor living conditions, unstable housing construction, deficient health care and education, and diseases such as dysentery, malaria, and tuberculosis.

#### **5.5.4 Health**

El Carmen currently houses two hospitals and a first aid post. The hospitals are owned by the SNSP and Ferro Caja. The medical force includes only one doctor and several nurses, who are assisted by several midwives located throughout the region. Physicians are provided by the medical university in Sucre on a one-year rotational basis. The current physical condition of these hospitals and first aid post as well as their medical equipment is considered as deficient.

#### **5.5.5 Education**

There are one pre-school, five primary schools, and one secondary school providing basic education to the inhabitants of the region. Basic education is provided mainly by teachers who graduated from the local schools and attended a teacher's school in one of the main Bolivian cities. In addition to these schools, there is a polytechnic institute providing higher education.

#### **5.5.6 Cultural, Archeological and Recreational Resources**

A review of the "Ethnic, Territorial, and Archeological Map of Bolivia" indicated no cultural or archeological resources in El Carmen and the area located between the railroad and the pipeline right-of-way. However, a literature research of cultural and archeological resources within the area of influence of the project identified the following site in the general vicinity of the El Carmen Unit:

- Yoroba Site.- This site is located in the Chiquitanos settlement of Yoraba, between Aguas Calientes and Santiago. The site presents paintings of animals, geometric figures and humans.

The relative location of the Yoroba site within the area of influence of the project is shown in Figure 5.2.

Recreational spaces in the area include the town square, two small meeting halls, a coliseum, and several sports complexes including one soccer field.

### **5.5.7 Production Systems**

As previously indicated, the region is characterized by a strong presence of logging concessions and agricultural activities conducted by subsistence farmers (crop harvesting includes mainly citrics). Although livestock raising is conducted on a small scale, this activity has been developing significantly during the past two decades. In general, most of the revenues generated by the sale of logging, agricultural, and livestock products are not reinvested in the local economy. Instead, they are invested in stronger economies such as Puerto Suárez.

Most of the inhabitants are also subsistence farmers who produce the bulk of their food requirements as well as some cash crops. They are currently cultivating rice and citrus such as lemons, oranges, and grapefruit in lots ranging from 1 to 5 ha. These products are shipped to markets in different regions within and outside the Department of Santa Cruz. The agricultural production system implemented by these families is rudimentary, involving the "slash and burn" method. Frequent droughts in recent years have affected crop harvesting in the region.

### **5.5.8 Employment**

There is a high unemployment rate in the region. Approximately 60 percent of the economically active population in the urban and rural areas is currently unemployed. The remaining 40 percent are hired as laborers in the logging concessions and cattle ranches.

### **5.5.9 Infrastructure**

The main roadway infrastructure in the area includes the unpaved road that connects Santa Cruz to Puerto Suárez. Transportation infrastructure also includes the Santa Cruz-Puerto Suárez railroad system which provides daily service to the city of Santa Cruz, and service to Puerto Quijarro and Puerto Aguirre three days a week.

The 1992 Census recorded 447 houses in El Carmen area, including 439 single family homes and eight community homes. Most of the houses are constructed of mud, branches and straw, and were observed to be in poor condition.

Potable water and electricity (only from 6:00 in the afternoon to 11:00 at night) are supplied to only 20 percent of the population. At the time of the public meeting in El Carmen, electricity was not available to any of the general public. Both of the electric generators were out of service, in need of repair. Only a small generator to service the water plan was operational. Each house has its own septic tank for sanitary wastewater discharge since the region lacks a public sewer system. Long distance telephone service is provided by ENTEL.

## **5.6 PUERTO SUAREZ/PUERTO QUIJARRO (UNIT V)**

### **5.6.1 Land Use**

The Puerto Suárez/Puerto Quijarro Unit (Unit V) is located in the eastern portion of the study area, approximately 600 km east of the city of Santa Cruz. The Unit covers about 5,500 km<sup>2</sup> of

territory, which represents about 1.5 percent of the total area of the Department of Santa Cruz. The two major population centers in the Unit are Puerto Suárez and Puerto Quijarro.

Puerto Suárez (capital of the province) is considered to be the main administrative center of the region and is located approximately 17 km from the border with Brazil (Corumbá). Puerto Suárez is the main administrative center of this socioeconomic unit.

Puerto Quijarro, which has acquired regional importance in recent years due to its location, is the closest urban center to the border city of Corumbá, Brazil. It is located approximately 10 km from Puerto Suárez on the edge of the Tamengo Channel (where the Concepción Creek converges with the Caceres Lake) and about 4 km from Corumbá.

Two small settlements are also located within this socioeconomic unit. These are: Suárez Arana (also known as Paradero) and Arroyo Concepción. These small communities are considered as part of an integrated urban system, whose main center is Puerto Suárez.

In general, the economy of the region is based almost exclusively on activities involving border trade. As part of the Regional Development Plan for the Department of Santa Cruz, this region is considered of particular importance, since it should become the center of development of the southeast portion of Bolivia for industries closely tied to the Brazilian markets. Among industries currently established in the region are fertilizer, polymer and cement production plants. In addition to these industries, a more intensive exploitation of iron in the Mutún mining zone is also planned as part of this Development Plan.

The objective of existing and future projects in the region is to endow the Department of Santa Cruz with an industrial and mining base for export. This also involves the current construction of the commercial and industrial free trade zone ZOFRAMAQ (to be completed in August 1996) and the upgrading of the existing transportation system, primarily with the construction of Puerto Bush on the Paraguay River. The main purpose of this port will be to allow access to the Atlantic Ocean.



The only primary production activity that has an important economic impact in the region is livestock raising. However, due to a lack of stable livestock industry in the country, the majority of the production is consumed locally or exported to Brazil. Milk and other lactic derivatives are almost non-existent in the region. Agriculture is very scarce, although there are a few farmers dispersed throughout the region, dedicated to agricultural activities only when the economic conditions of the region are favorable.

### **5.6.2 Political and Social Organizations**

Given the characteristics and strategic importance of the zone as the main border area with Brazil, there has always been a strong government presence with the armed forces (Army and Navy), Narcotics Unit, National Police, and Customs and Immigration Offices to safeguard the sovereignty of the Bolivian territory.

#### **Puerto Suárez**

The official entities located in Puerto Suárez are as follows: the Sub-Prefecture, Mayor's Office, Civil Register (Registro Civil), and Civil Committee.

There are 25 OTBs represented by 2 indigenous communities, 9 peasant communities, and 14 neighborhood councils. Other institutions present in the region include several banks, savings and loan cooperatives, and a Mother's Club (dedicated mainly to goodwill work). The religious sector is represented principally by the Catholic Church and, to a lesser degree, by the Evangelical Church.

#### **Puerto Quijarro**

The official entities located in Puerto Quijarro are as follows: Chief Magistrate, Customs and Immigration Office, Internal Tax Revenue Office, and District Management Office for Education.

There are 15 OTBs represented by 2 peasant communities and 13 neighborhood councils. Other institutions present in Puerto Quijarro include a border fraternity and a Mother's Club (dedicated mainly to goodwill work). The religious sector is also represented principally by the Catholic Church and to a lesser degree by the Protestant Church.

### 5.6.3 Population

The 1992 Census data indicated that the total population for these two centers was 16,187 inhabitants (9,863 in Puerto Suárez and 6,324 in Puerto Quijarro). The total population is distributed as 52.8 percent males and 47.2 percent females. The "young" population (0 to 14 years of age) represented 41 percent, the "active" population (15 to 64 years of age) 57 percent, and the "senior" population (65 years and over) 2 percent.

The general structure of the population in the region is presented in the following table:

Gender	Total Number of Inhabitants	Number of Inhabitants between 0-14 years of age	Number of Inhabitants between 15-64 years of age	Number of Inhabitants 65 years of age and over	Number of Inhabitants with age not specified
Men	8547	3327	5034	169	17
Women	7640	3232	4240	149	19
Total	16187	6559	9274	318	36

As with the previous units, the growth rate of the population is 4.16% according to 1992 census. Based on this growth rate, the projected population of Puerto Suárez and Puerto Quijarro for 1996 is about 11,599 and 7,437, respectively.

The population of the region consists principally of two very distinct ethnic groups referred to as "collas" and "cambas." The colla people consist of "Quechua" and "Aymara" indigenous groups

which immigrated to the area from the high lands of the western region of Bolivia. This ethnic group is mainly involved in small scale businesses that include food retail and transportation. The camba people are originally from the low lands of the eastern and northern regions of Bolivia. This group is mainly employed in a variety of private companies and industries or in government offices.

A foreign migration into the region has also occurred due mainly to the existence of labor opportunities in the commercial and industrial sectors. The foreign migration is generated from the bordering countries, principally Brazil and Paraguay.

#### **5.6.4 Health**

Puerto Suárez currently houses one hospital and four private clinics. The medical work force in these health centers includes six doctors, four medical assistants, and six nurses, assisted by three midwives located throughout the region.

In Puerto Quijarro, there is only one hospital and one first aid station. The number of doctors, nurses, assistants and midwives serving these health centers was not available at the time the Socioeconomic Public Consultation Program was conducted.

#### **5.6.5 Education**

In Puerto Suárez, there are currently three pre-schools, four primary schools, and two secondary schools. In addition to these schools, there are two polytechnic institutes providing higher education. The number of students attending these schools is approximately 7,330, and the professional teaching staff serving the students is composed of about 310 persons.

In Puerto Quijarro, there are five pre-schools, ten primary schools, and ten secondary schools. However, this sector does not have any technical schools or universities.

### **5.6.6 Social, Cultural and Archeological Resources**

A review of the "Ethnic, Territorial, and Archeological Map of Bolivia" indicated no cultural or archeological resources in Puerto Suárez, Puerto Quijarro, and the area located between the railroad and the pipeline right-of-way. A literature research of cultural and archeological resources within the area of influence of the project did not identify any site in the general vicinity of the Puerto Suarez-Puerto Quijarro Unit.

Recreational facilities in Puerto Suárez include the town main square, several playgrounds, a conference room, two small libraries, the house of culture, and several discotheques and karaoke. In Puerto Quijarro, there are two libraries and several discotheques and karaokes.

### **5.6.7 Production Systems**

The economic role of this region is limited to serving as a "trade bridge" between Brazil and Bolivia, and most of its inhabitants have economic interests directly or indirectly related to the border trade business.

Border trading occurs on two levels, legal and illegal. Legal trading is carried out by national companies that acquire goods directly from factories in São Paulo and other major cities in Brazil, and then transport them to Puerto Quijarro. The merchandise is appraised by the Bolivian National Customs Service and then shipped by train to Santa Cruz.

Illegal trading, which is conducted by smuggling foreign goods across the border, has a significant impact on the region's economy. Smuggling of goods into Brazilian territory from Bolivia also occurs, although on a much reduced scale. Illegal trading in the area also involves drug smuggling. These drug related activities are conducted not only as direct sale to foreign buyers but also by exchanging motor vehicles for drugs. Although these activities have diminished significantly in recent years, they are still quite widespread through the region.

The industrial sector in the region is represented principally by iron exploitation, and the production of fertilizers, polymers and cement. Currently, the small quantities of iron that are produced in the Mutún mining complex are exported to Brazil via Corumbá. The mining exploitation in Mutún is carried out by the State Mining Company of the West (Minera Estatal del Oriente-EMEDO). The company operates two processing facilities, with a combined capacity of refining three million metric tons of iron per year. However, this potential capacity is not used in its entirety, as only approximately 15 thousand metric tons of refined iron are produced annually. There are also three relatively important sawmills that process wood extracted from the Carmen forestry concessions.

### **5.6.8 Employment**

Employment rates in the region are extremely variable since the economy in Puerto Suárez and Puerto Quijarro is related mainly to border trading with Brazil, which in turn depends on the economic conditions in Bolivia. A large portion of the population is employed by these two economic sectors. The effects caused in the region's economy by the variability of the employment rates are minimized by the population's overall versatility and capacity to relocate to and from Santa Cruz and other major cities in the country.

In addition to the population directly involved in trading, there are also a significant number of people providing merchants and businesses with transportation and food supply services. Another source of employment in the region is the different government institutions present and ENFE.

### **5.6.9 Infrastructure and Services**

The main roadway infrastructure in the area includes the unpaved road that connects Santa Cruz to Puerto Suárez and the paved road that connects Puerto Suárez, Puerto Quijarro, and Corumbá. Transportation infrastructure also includes the Santa Cruz-Puerto Suárez railway. The railway, although in poor physical condition, has played an important role in providing transportation in the region and has caused a significant impact on the growth of the intermediary population centers

between this region and Santa Cruz. The number of passengers using the railroad fluctuates on average between 600 and 1,000 people per day.

One of the most important means of transportation to and from the region is the Puerto Suárez Airport. Air traffic at the airport averages two arrivals and two departures per day. The airport facilities are used mainly by the local airlines LAB (Lloyd Aéreo Boliviano), Aerosur, and TAM (Transporte Aéreo Militar).

The existing port infrastructure is also important for the economic development of the region. The two ports currently in operation are the Port of Aguirre, a private complex connected to the railroad, and the Naval Port. The main function of the Port of Aguirre is to serve as a shipping port for soybeans produced in the Department of Santa Cruz, which are subsequently sent in Paraguayan ships to European markets. The second port belongs to the Bolivian Navy, and is located in the village of Tamarinero, approximately three kilometers north of Puerto Quijarro. In addition to these existing port facilities, there are proposed projects to construct two additional ports, Tamengo and Bush.

The 1992 Census recorded 2,059 houses in Puerto Suárez and 1,374 in Puerto Quijarro, including 2,020 single family homes and 39 community homes in Puerto Suárez, and 1,340 single family homes and 34 community homes in Puerto Quijarro. Most houses located within the boundaries of these two centers are constructed of cement and bricks, and were observed to be generally in good condition. In contrast, houses located on the outskirts of these centers are constructed of mud, branches, and straw, and were observed to be generally in poor condition.

There is only one potable water supply distribution system for Puerto Suárez, Suárez Arana (Paradero), Puerto Quijarro and Arroyo Concepción. The system supplies potable water to only 40 percent of the population. A large number of houses in these four centers have their own septic tank for sanitary wastewater discharge since the construction of the public sewer system is only one third completed. Electricity for the urban centers is purchased from Brazil due to lack of generation resources in the region.

There have been some indications of economic diversification based on the exploitation of tourism in Puerto Suárez, although this diversification does not have a significant impact on the region's economy. The infrastructure of hotels, lodgings, and restaurants in general is considered of mediocre capacity and physical conditions. The services offered at the majority of the hotels in the region, with the exception of one five-star hotel, are rated as deficient.

There are a significant number of potential infrastructure projects to be implemented in the area, but the most important project is the current construction of the ZOFRAMAQ free trade center or zone. The objective of this project is to provide a system that will attenuate and/or eliminate factors that delay or hinder exporting commercial transactions. This center would also allow the production sector and businesses the possibility of immediate access to merchandise or imported and/or exported goods, thus reducing financial costs and promoting the growth of the internal markets.

The center area consists of 130,000 hectares of land, located on the Puerto Suárez-Santa Cruz road, 6 km from the Puerto Suárez airport, 11 km from the Corumba airport (Brazil), and 3 km from the Paraguay - Paraná Hidrovia. The free trade center will also be connected to the existing Santa Cruz-Puerto Suárez railway.

## **5.7 INDIGENOUS PEOPLES**

With two major Indigenous groups and several lesser ones, Bolivia has the most significant indigenous population of any country on the South American continent. Between 50 percent and 60 percent of the total population is of pure Indigenous blood, about 35 percent is made up of "mestizos" (a mixture of Spanish and Indigenous blood), and less than one percent is of African heritage. The remainder of the population is primarily of European descent, with a small Asian minority.

Recent studies in Bolivia indicated that the Indigenous population in the Department of Santa Cruz is approximately 128,000 inhabitants dispersed over the area or mixed with other groups. The

Indigenous groups located within the study area are the Ayoreos, the Chiquitanos, and the Izozeño Guaraní communities.

### 5.7.1 Ayoreos

The Ayoreos indigenous population located within the study area consists of eight communities with a total of 838 inhabitants, according to the 1994 Census of Indigenous Peoples of Oriente, Chaco and the Amazon. The Ayoreos group has a transient economy and semi-nomadic culture, and occupies an extended area in the southern part of what is now the Department of Santa Cruz, and the northern Chaco area of the neighboring country of Paraguay.

The initial interactions with this group by persons from outside the region are reported to have started in the 1930s, and were reportedly violent. By the end of the 1940s, Protestant and Catholic groups had persuaded them to adopt a sedentary way of life, and to settle in missions in order to be assisted and evangelized.

The Ayoreos are an organized group and are represented by their highest authorities in the Confederación Ayorea del Oriente Boliviano - CANOB (Ayorean Confederation of People of the Oriente), and are associated with the Confederación Indígena del Oriente Boliviano - CIDOB (Indigenous Confederation of people of the Oriente). The Ayoreos currently live in communities located on both sides of the Santa Cruz-Puerto Suárez railroad, to the north of the railroads the communities are Azpocó, Puesto Paz, Tobité, Rincón del Tigre, and to the south, Yoquiday (Poza Verde), Santa Teresita, Santiago, Urucú, and El Carmen. There have been other attempts to establish settlements south of the railway, one close to Yoquiday and another in the area of Puerto Suárez.

In general, the Ayoreos do not hold title to the lands they occupy. The Ayoreos have the right to possess and use them, but the legal titles are held in the names of the missions, or by the State. During visits to these communities, it was found that land at Poza Verde, Puesto Paz, Urucú and Santiago is registered under the names of the missions; and that Santa Teresita and Tobité are in the name of the Ayoreos. Ayoreos lands in El Carmen belong to the local Municipality.



As to their cultivation practices in the shrub lands, the Ayoreos recently introduced the practice of clearing land for planting, and they are now probably the best workers there are for cutting trails and roads. Because of their knowledge of timber handling, the Ayoreos are also valued by lumber contractors. Ayoreos agriculture is a means of survival at the subsistence level. As to technology, few communities use machinery and equipment. In some cases it is used on mission lands, more than in community fields. The use of chemicals is limited.

Hunting provides the Ayoreos with approximately 70 percent of their meat and protein. They avoid eating beef or poultry. On the contrary, their favorite meat is what they find in the forest, i.e., armadillos, iochis and turtles. However, it is common to hear the Ayoreos speak of using the fauna and flora only for the most vital needs.

Although fishing is an activity mentioned in some studies of the Ayoreos, no significant evidence of this activity was found in the field work, except for some areas close to rivers, or with access to marshlands. Traditionally, the Ayoreos have practiced apiculture. According to several authors, the Ayoreos were familiar with about 30 species of bees, and raised them using rudimentary systems to produce honey.

Another important category of economic activity for the Ayoreos is salaried employment at private sawmills, where the work ability and capacity of this indigenous group is evident. The Ayoreos also provide day-labor for neighbors in villages close to their communities, carrying wood, and working at different jobs as laborers in the forest. However, monetary income from occasional work is barely enough to purchase basic consumer products such as sugar, mate, oil, rice, noodles, soap, salt, matches and some school supplies.

The Ayoreos are involved in the production of woven handicrafts, bags, small hammocks, rugs and so on, which are sold in towns and in the city of Santa Cruz. This is mainly a female activity, and is especially important in the community of Santiago. A certain degree of technical specialization and training has been achieved here, allowing these products to be exported through missionaries.

### 5.7.2 Chiquitanos

The Chiquitanos indigenous population located within the study area consists of 22 communities with a total of 2,819 inhabitants, according to the 1994 Census of Indigenous Peoples of Oriente, Chaco and the Amazon. In contrast to the Ayoreos people, the Chiquitanos have been an essentially sedentary group for more than a century, due to Jesuit activities during colonial times. Due to the degree of assimilation which has taken place, members of this group can be difficult to identify at first glance.

The Chiquitanos currently live in the provinces of Chiquitos, Nuflo de Chávez, Velasco, and San Ignacio. In Chiquitos, they are dispersed in small communities, farms and ranches, and within the area of influence of the town of San José de Chiquitos, there are 19 communities with populations of Chiquitanos or Chiquitano-mestizo origin. Chiquitano communities are small in accordance with their condition as small or subsistence producers.

The Chiquitanos are mainly involved in agricultural and hand crafting activities. Their main crops include rice, cacao, corn, yuca, peanuts, pineapple, and tobacco. While the majority of the male population is typically involved in agricultural, hunting and fishing activities; women are dedicated household activities and to the production of woven handicrafts.

### 5.7.3 Izozeño-Guaraníes of CABI (Unit VI)

The Izozeño Guaraní group includes 22 communities which constitute *The Capitanía del Alto y Bajo Izozog* (CABI). The CABI community is settled within the Izozog Wetlands (Bañados de Izozog) which is located along the Parapetí River watershed. The Parapetí watershed is one of the few remaining areas within the Bolivian territory where native semi-dry and semi-temperate forests still exist. In addition, the majority of its population (80 percent or more) belongs to indigenous communities.

CABI belongs to the Guaraní Town Assembly or *Asamblea del Pueblo Guaraní* (APG), which is a regional organization of all Guaraní settlement groups or towns. The Guaraní Town Assembly

belongs to CIDOB, which is the national organization of indigenous settlements. CABI is the first legally established Indigenous submunicipality in Bolivia. Its jurisdiction covers the *Alto and Bajo Izozog*.

The main role of CABI is to protect and preserve the native ecosystem according to Bolivian Law No. 1551. The CABI organization was instrumental in establishing the Gran Chaco National Park and Integrated Management Area, which was officially authorized by signing of a Bolivian Presidential Decree in September, 1995. The Chaco is one of the largest protected areas in South America, and contains the highest mammalian biodiversity on the continent.

Administratively, CABI practices a democratic system based upon the Law of Popular Participation. To win an election requires a consensus in which there is unanimous agreement on the people to be elected. CABI has an annual meeting of 200 delegates in which the administration gives information about the previous year's programs, explains how funds were administered, and presents a budget for the following year.

CABI has a traditional justice system, without police. A Grand Captain, "mburubicha guazu", has authority over the 8,000 people. The Grand Captain is currently Mr. Bonafacio Barrientos. There are two vice-captains, one responsible for the high Izozog, and the other responsible for the Low Izozog. Each group has four assistants, and there are representatives from each of the communities. Discipline for civil or criminal injustice is administered by the Grand Captain. In extreme cases, people are excommunicated or banned from the community.

The family is the most important unit within the Izozog community, and represents the economic and political center of the region. Within this context, the family unit regulates and distributes available productive land and natural resources for the following activities: domestic cores, livestock raising, cultivation in small family gardens, and community social services.

CABI is comprised of 22 communities located along a 100 km stretch of the Parapetí River. The 22 groups which belong to CABI are as follows:

1. Aguaraty	12. Kopere Montenegro
2. Aguarayba	13. La Brecha
3. Capeatindi	14. Mini
4. Carapari	15. Rancho Nuevo
5. Coropo	16. Rancho Viejo
6. Cuarirenda	17. Tamane
7. Isiporenda	18. Tamasindi
8. Ivasiriri	19. San Silvestre
9. Kopere Brecha	20. Yapiroa
10. Koeray Guasu	21. Yobi
11. Kopere Loma	22. Yugui

In 1992, there were a total of approximately 1,340 families with 7,500 members living in this socioeconomic unit (1992 census). The general structure of the population in the High and Low Izozog in 1992 is provided in the table below.

Location	Males	Females	Total Population	Homes
High Izogog	1569	1518	3087	517
Low Izogog	2188	2230	4418	823

The National Council of Agrarian Reform granted nine land property rights titles to the Izozog community between 1967 and 1987. This land was to be parceled into sixteen different lots and included approximately 64,300 hectares (ha). In addition, a request was made for another 5,400 ha. This land division provides each family with approximately 55 ha. of land. Each family community utilizes an average of 1.5 ha. of land for agriculture, and there is an estimated deficit

of about one ha per family to cover its basic living needs. There is a temporary migration for seasonal agroindustrial jobs with respect to the regional job market within the Izozog community.

Their educational programs include bilingual education to teach their children not only Castellan Spanish but also Guarani. There is an agreement between CABI and the Normal de Chiragua, a university for teachers, which is implementing bilingual educational programs. The school system has 16 schools and 69 teachers, including 60 bilingual teachers and 9 who speak only Spanish.

CABI has been considering the possibility of developing and coordinating traditional medicine in the area, which is significantly less expensive than western medicine. They have four medicine men in the community, who are called "chamanes". They are involved in research activities and have developed four medications, in conjunction with the University of San Andres in La Paz, which are sold in local hospitals.

CABI has one hospital in La Brecha, four clinics, one doctor and sixteen nurses. They have an agreement with the Red Cross of Switzerland that was set up in the area approximately five years ago. Several other international organizations are active in the area to develop education and training programs to assist the people in understanding better use of the land, including APCOB and the Centro de Investigacion Agricultura Tropical (CIAT/CIPCA).

The CABI community has three programs in place for the administration, development and management of the Gran Chaco National Park, which are described as follows:

- World Bank financing for internal park management;
- A community mapping program for sustainable development to protect the primary sources of livelihood, which are hunting, fishing, and agriculture; and
- A natural resources planning program which focuses on the protection of biodiversity.

The interactive process between the population and the natural ecosystem in this socioeconomic unit is considered to be a part of a subsistence economy. This economy is based on the use of natural resources and the implementation of production activities. Natural resources include

mostly fishing, hunting, and collection of forest products for consumption and other uses. All these activities form part of a well-balanced system to protect, preserve, and control the flora and fauna biodiversity in the region

Production activities carried out by the individuals in the Izozog community are also for subsistence purposes and include mainly small scale crop cultivation, domestic animal raising such as goats, pigs, ducks, chickens, cattle and horse raising, hand-made manufacture of domestic tools, ceramic handcrafts, and textiles, etc.

Ongoing economic activities of this group include, among others:

- water resource management;
- manufacturing of domestic utensils;
- commercial textile;
- manufacturing of soap
- food by-products;
- ceramic production;
- manual engineering design; and
- construction and repair of fourteen irrigation channels throughout the High and Low Izozog areas.

Transportation, water supply and disease represent significant problems within the CABI region. The availability of potable water is a major issue for sustainable development in the area. Only 18 of the communities have water supply from wells. Four more wells are needed to provide water to all twenty two communities. Electrical service is available only at La Brecha. The *chagas disease* is transmitted through an insect and little if any programs are available for its prevention. A medical laboratory is needed to investigate and research this illness.

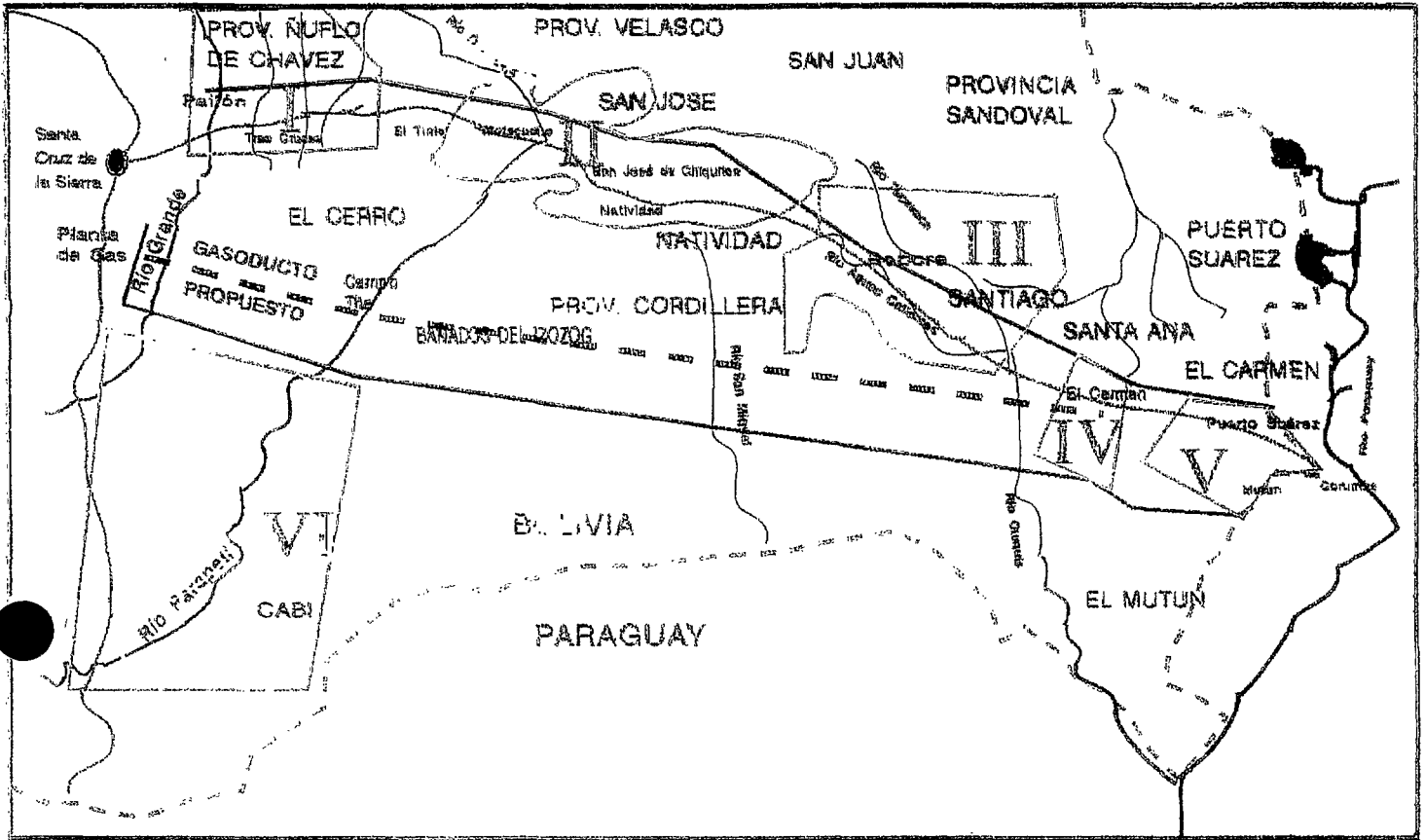

**LEGEND:**

- Bolivian Border
- Rivers
- Socio-Economic Units
- Boundary Study Area
- Proposed Gas Pipeline Route
- Railroad
- Area of Guarani Settlements

**SOCIO-ECONOMIC UNITS:**

- I Pailón
- II San José
- III Robore
- IV El Carmen
- V Puerto Suárez
- VI Cabi

*Bolivia to Brazil Gas Pipeline (Bolivian Portion)*  
**Location of Socioeconomic Units**



*Figure 5.1*

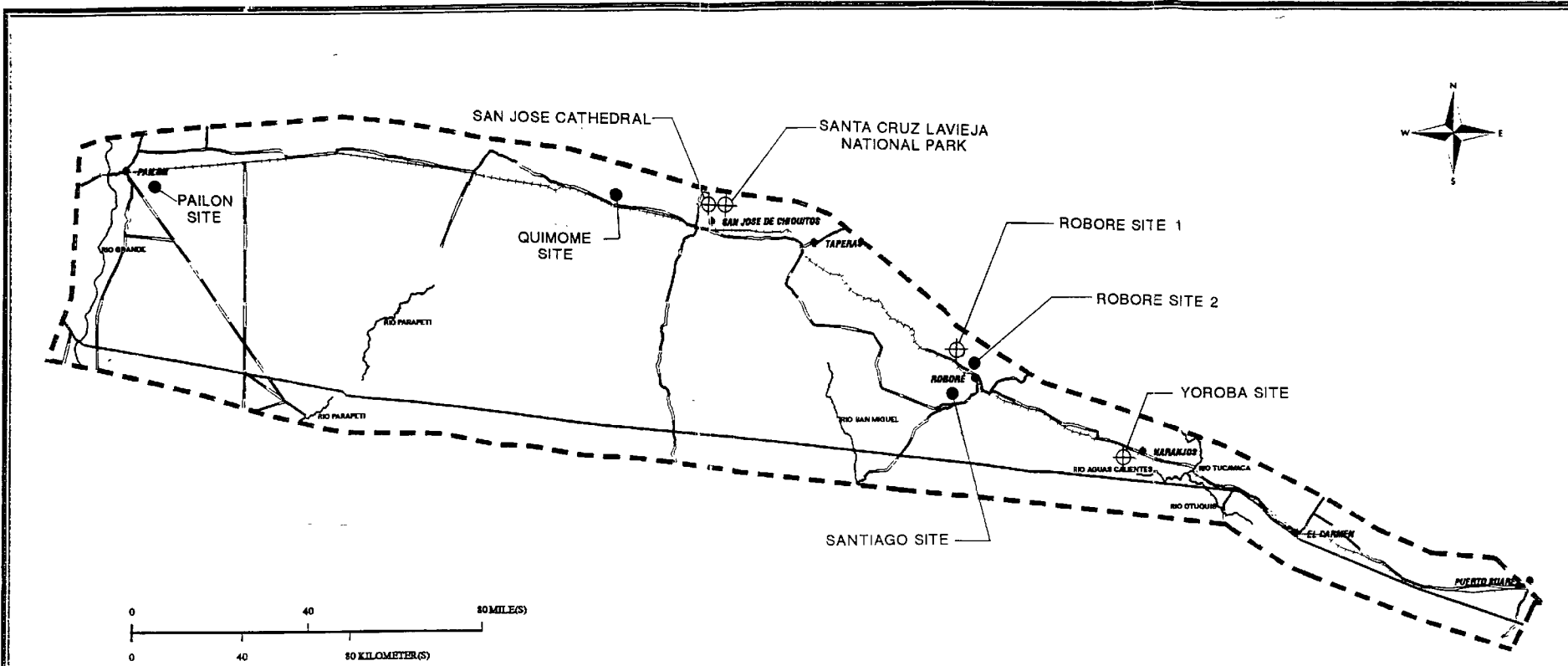

- LEGEND:
- ⊕ CULTURAL SITE
  - ARCHEOLOGICAL SITE

BOLIVIA TO BRAZIL GAS PIPELINE (BOLIVIAN PORTION)  
 CULTURAL AND ARCHEOLOGICAL SITES



FIGURE 5.2

Reference: Topographic Maps of the Geographic Military Institute (1:250,000)



**CHAPTER 6.0**  
**ENVIRONMENTAL IMPACTS**

**TABLE OF CONTENTS**

6.1	GENERAL	6 - 1
6.1.1	Impacts Evaluation Methodology	6 - 1
6.1.2	Environmental Parameters	6 - 2
6.1.3	Project Activities	6 - 3
6.1.4	Impacts Classification	6 - 3
6.2	IMPACTS ON THE PHYSICAL ENVIRONMENT	6 - 6
6.2.1	Air Quality	6 - 6
6.2.1.1	Emission Sources	6 - 6
6.2.1.2	Methodology	6 - 8
6.2.1.3	Modeling Results	6 - 9
6.2.2	Geology, Geomorphology, Soils, and Seismicity	6 - 12
6.2.2.1	Geology	6 - 13
6.2.2.2	Geomorphology	6 - 13
6.2.2.3	Soils	6 - 13
6.2.2.4	Seismicity	6 - 16
6.2.3	Water Resources	6 - 16
6.2.3.1	Hydrology	6 - 17
6.2.3.2	Hydrogeology	6 - 19
6.2.3.3	Water Quality	6 - 20
6.2.4	Noise and Lighting	6 - 23
6.3	IMPACTS ON THE BIOLOGICAL ENVIRONMENT	6 - 23
6.3.1	Vegetation	6 - 23
6.3.2	Fauna	6 - 25
6.3.3	Species of Special Concern	6 - 27
6.3.4	Protected Areas	6 - 28
6.4	IMPACTS ON THE SOCIOECONOMIC ENVIRONMENT	6 - 28
6.4.1	Land Use	6 - 29

**CHAPTER 6.0**  
**ENVIRONMENTAL IMPACTS**

**TABLE OF CONTENTS**

6.4.1.1	Temporary Land Use Change . . . . .	6 - 29
6.4.1.2	Permanent Land Use Change without Resettlements . . . . .	6 - 30
6.4.1.3	Permanent Land Use Change with Resettlements . . . . .	6 - 30
6.4.1.4	Indirect Land Use Impacts . . . . .	6 - 30
6.4.2	Social Impacts . . . . .	6 - 31
6.4.2.1	Population . . . . .	6 - 31
6.4.2.2	Public Health and Safety . . . . .	6 - 31
6.4.2.3	Education and Training . . . . .	6 - 33
6.4.2.4	Indigenous Peoples . . . . .	6 - 33
6.4.2.5	Cultural and Archeological Resources . . . . .	6 - 34
6.4.3	Economic Impacts . . . . .	6 - 34
6.4.3.1	Project Revenues . . . . .	6 - 34
6.4.3.2	Employment . . . . .	6 - 35
6.4.3.3	Infrastructure . . . . .	6 - 36
6.5	RISK ASSESSMENT . . . . .	6 - 38
6.5.1	General . . . . .	6 - 38
6.5.2	Safety Performance of Gas Pipelines in the U.S. . . . .	6 - 39
6.5.3	Assessment of Pipeline Hazards . . . . .	6 - 41
6.5.4	Risk Control . . . . .	6 - 42

**CHAPTER 6.0  
ENVIRONMENTAL IMPACTS**

**LIST OF TABLES**

<b><u>TABLE NO.</u></b>	<b><u>DESCRIPTION</u></b>
6.1	SUMMARY OF IMPACTS AND MITIGATION MEASURES FOR THE BOLIVIA TO BRAZIL GAS PIPELINE PROJECT (BOLIVIAN PORTION)
6.2	AREA OF VEGETATION, SOILS, AND FORESTRY POTENTIAL TYPES AFFECTED BY THE CONSTRUCTION OF THE RIGHT-OF-WAY

## 6.0 ENVIRONMENTAL IMPACTS

### 6.1 GENERAL

The potential impacts on the existing physical, biological, and human environment resulting from the construction, operation, and abandonment of the proposed gas pipeline project are identified and described in this chapter. The discussion includes both beneficial and adverse impacts and their significance. Impacts are defined as those changes to the baseline conditions that are a direct or indirect consequence of the project.

Where possible, impacts are described in quantitative terms. In other instances, a qualitative evaluation was conducted based on the professional experience and judgment of the assessment team and importance to the people potentially affected by the project. Such impacts may be direct or indirect, short term or permanent, localized or regional. Some potential impacts are avoidable and some adverse impacts may be mitigable. Secondary impacts are also discussed.

Mitigation measures to avoid or minimize environmental impacts are presented in the Environmental Management Plan of Chapter 7.

#### 6.1.1 Impacts Evaluation Methodology

Conceptually, potential environmental impacts are identified and evaluated by comparing proposed construction and operation activities with the baseline environmental conditions of the project area and predicting modifications on the physical, biological and socioeconomic baseline conditions. In practice, impacts may be identified, classified, and evaluated using a variety of techniques, such as matrices, modeling, and map overlays. In this study, impacts were analyzed using a combination of matrices, modeling, and map overlays developed in a Geographic Information System (GIS).

An impact identification matrix was used to determine associations between the project activities and the environmental parameters, based on predicted modifications to the existing environmental conditions as a result of construction and operation of the project. For each possible combination

of activity and environmental parameter, an assessment was made as to whether the baseline condition of a given environmental parameter is likely to be modified by the project activity. For example, the activity "right-of-way clearing" will result in a modification in the environmental parameter "vegetation cover", because of the reduction of areas covered by vegetation. The GIS-based map overlays were used in the quantification of the impacts on individual environmental parameters such as soils and vegetation.

### **6.1.2 Environmental Parameters**

The following key environmental parameters were identified to evaluate potential impacts of the project:

- **Physical Environment**
  - Climate and Air Quality
  - Geology, Geomorphology, and Soils
  - Water Resources
  - Noise
  
- **Biological Environment**
  - Vegetation
  - Fauna
  - Species of Special Concern
  - Protected Areas
  
- **Socioeconomic Environment**
  - Population
  - Economy
  - Indigenous People
  - Cultural, Historical, and Archeological Resources

### 6.1.3 Project Activities

Project activities were summarized into the following categories:

- Construction
  - Construction of Work Camps and Storage Yards
  - Construction of Compressor Stations and Pig Launchers/Receivers
  - Access Road Improvement
  - Transportation Activities (pipe, supplies, and workers transportation)
  - Clearing and Grading
  - Trenching
  - Pipe Bending, Laying, and Welding
  - Pipe Lowering and Backfilling
  - Hydrostatic Testing
  - Above Ground Appurtenances
  - Waste Management
  - Final Cleanup
  
- Operations
  - Normal Operations
  - Waste Management Operations
  - Spills or Fires
  - Maintenance
  
- Abandonment
  - Demolition
  - Transportation

### 6.1.4 Impacts Classification

A variety of beneficial and adverse impacts will result from the development and operation of the project. The Project Sponsors are developing plans to distribute the beneficial impacts under their

control, such as employment, purchasing of goods and services, and construction of related infrastructure, to groups and communities that would be affected by the project. For impacts described as adverse, significant, and mitigable, the recommended mitigation actions are described in Chapter 7.0. All impacts associated with the project, both beneficial and adverse, are identified, discussed, and classified in the remainder of this chapter. Tables 6.1 and 6.2 present a summary of the potential impacts and key mitigation measures. Application of appropriate mitigation measures will reduce impacts to acceptable levels.

A common set of terms has been used for assessing and comparing impacts from the various facilities and activities associated with the project. The duration or actual time the resource would be affected by the project is provided for the resources being analyzed. Temporary, Intermittent or Permanent are used, as appropriate to describe duration. Temporary and Intermittent impacts are most often related to construction, which for most elements of this project is less than one year in duration. Permanent impacts are most often related to operation, which covers the remainder of the project, assumed to be 20 years or more.

The duration of the impacts described in the following sections is discussed in terms of construction and/or operations impacts. The magnitude (i.e., local versus regional) is also provided where appropriate. Magnitude generally refers to the size or physical extent of the impact being described. Impacts have been assessed based upon published and unpublished information, field surveys, and analytical procedures, which included numerical screening of atmospheric emissions associated with the proposed four compressor stations to be located in Bolivian territory.

Impacts were classified as follows:

- Effect
  - Beneficial
  - Adverse

- Cause-Effect Relationship
  - Direct
  - Indirect
  
- Degree
  - Significant
  - Insignificant
  
- Duration
  - Permanent
  - Temporary
  
- Magnitude
  - Extended (over a large area)
  - Localized
  
- Location
  - Proximal (effect is evident within one kilometer from the causal activity)
  - Remote (effect is evident more than one kilometer away from the causal activity)
  
- Reversibility
  - Reversible
  - Irreversible
  
- Mitigation
  - Mitigable (its effects may be minimized, reverted or nullified)
  - Not Mitigable
  
- Association with other impacts
  - Cumulative
  - Synergistic



## **6.2 IMPACTS ON THE PHYSICAL ENVIRONMENT**

### **6.2.1 Air Quality**

An impact to air quality is considered significant if it could cause substantial change in air quality in areas located within or nearby the sites of project construction and/or operation activities. The potential impacts identified are associated with the following activities or conditions in the study area:

- Emission sources associated with site grading and road and building construction activities.
- Pollutants related to construction equipment exhaust and welding activities.
- Emission associated with the operation of the proposed four compressor stations sited on Bolivian territory.

The following discussion identifies potential sources of air pollutant emissions that would be introduced by the project, provides an overview of the impact assessment methodology, and describes the results of the model.

#### **6.2.1.1 Emission Sources**

Emission sources would be created during both the construction and operation phases of the project. During construction, the project would introduce temporary emission sources associated with site grading and road and building construction activities. Such activities would occur along the pipeline right-of-way and at locations of roadway improvements. The primary pollutant emission associated with construction activities would be dust, or particulate matter having a diameter of less than 10 microns ( $PM_{10}$ ), generated from site grading and other earthmoving activities.

Uncontrolled dust emissions from earthmoving activities would likely lead to high concentrations of particulates in the area immediately surrounding the construction site. In the dry season, the increased vehicular traffic on the dirt road between Santa Cruz and Puerto Suárez as well as on the access roads between the main road and the right-of-way, are expected to generate significant

dust clouds. These occurrences will be temporary and localized, but may become an annoyance to drivers and workers. Dust may be transported by wind and settle on the vegetation adjacent to the roads, up to a few dozen meters from the road. It is unlikely that the dust will have any detectable effects on either the vegetation or the local fauna.

Other pollutants expected during construction activities include sulfur dioxide (SO<sub>2</sub>) and nitrogen oxides (NO<sub>x</sub>). These emissions, associated with construction equipment exhaust and welding activities, are not expected to result in high concentrations of these pollutants. Construction equipment exhaust emissions would be minor and would be dispersed throughout the area in which construction equipment operates. Localized release of vapors associated with fueling activities will be ephemeral. Workers conducting such activities will be momentarily exposed to the vapors, but no negative effects are likely, as long as these activities are conducted in open spaces and undue spillage is prevented. Consequently, impacts associated with construction emissions are considered less than significant due to their localized and short-term nature.

During operation of the pipeline, emission sources will be related to the proposed four compressor stations sited on Bolivian territory. Although the project has been designed to start with only one compressor station, air emissions have been evaluated for the operation of all four compressor stations which are to be constructed, one at a time, as the gas sales to Brazil increase in response to an added demand for energy. The operation of the four compressor stations was screen-modeled using the simulator program SCREEN3.

The pollutants evaluated for the operation phase of the project included Nitrogen Oxides (NO<sub>x</sub>), Carbon Monoxide (CO), and Particulate Matter less than 10 microns in diameter (PM<sub>10</sub>). Impacts predicted using the SCREEN3 model were compared with the current Bolivian National Ambient Air Quality Standards (NAAQS) and World Bank Guidelines for Onshore Oil and Gas Development. The following sections present a summarized description of the computer analysis used to evaluate air emissions during the operation of the project. A detailed report on the air analysis is presented in Appendix A.

### 6.2.1.2 Methodology

The simulator program SCREEN3 was used to screen-model the operation of the four compressor stations proposed in Bolivian territory. This program is classified as a Gaussian model because the pollutant mass (i.e. concentration) is assumed to follow a bell-shaped curve, or normal distribution. When following a Gaussian distribution, the maximum concentrations associated with a source's emission plume are highest in the center of the plume and taper exponentially to almost zero in both the horizontal and vertical directions. The edge of an emission plume is defined as the point where the concentration drops to 10% of the centerline value.

The SCREEN3 model performs single source, short-term calculations that estimate maximum off-site ground-level concentrations. This model also provides the distance to the maximum off-site impact, incorporates the effects of building downwash on the maximum concentrations for both the near wake and far wake regions, estimates concentrations in the cavity recirculation zone, and estimates concentrations due to inversion break-up.

Meteorological data used in the SCREEN3 is limited to a "worst-case" combination of wind speed and stability parameters. The model evaluates a range of wind speeds, ranging from 1.0 m/s to 20.0 m/s, and six stability classes ranging from unstable (well mixed atmosphere), through neutral, to stable (essentially no mixing). From these conditions, the "worst-case" combination that will result in the highest ground-level concentration is used in the model. SCREEN3 considers only one direction, predicting impacts at user-specified distances to quickly get an "absolute, worst-case" estimate of the source(s) impact on the air quality of the region.

For each compressor station, it was assumed that the turbines are housed in a compressor building, with the emission stack roughly 3.5 meters above the building height. The dimensions of the building used in the simulation for downwash calculations are 20 feet wide, 30 feet long, and 25 feet tall (12 x 6 x 7.6 meters). The analysis assumed that the entire length of the pipeline will stretch across relatively flat terrain. Rural dispersion coefficients were used to simulate stability parameters in a forested/grassland region.

### 6.2.1.3 Modeling Results

The highest off-site impacts associated with the compressor stations along the pipeline were predicted using the SCREEN3 model. Two sets of screen modeling runs were performed for NO<sub>x</sub>, CO, and PM<sub>10</sub> pollutants to evaluate the impacts from both CENTAUR 50 and TAURUS 60 natural-gas fueled combustion turbines. The CENTAUR 50 turbine has a rating of 5680 horsepower (hp). The TAURUS 60 turbine is rated at 6960 hp. Both compressor units were evaluated to provide design alternatives for the project.

The analysis simulated two modeling scenarios. The first scenario considered four turbines housed in one building with only three in operation at any given time and the fourth serving as a stand-by unit. This scenario simulated three of the compressor stations along the pipeline by taking the predicted SCREEN3 impacts for one turbine in operation, and multiplying by three to obtain the impacts associated with three turbines in operation simultaneously. This conservative assumption was used to simplify the analysis and evaluate a "worst case" scenario based upon the expected configuration for compressor station #4. The second scenario simulated only one turbine in operation at the fourth station along the pipeline. The following tables summarize the results of the predicted emission rates as they compare to the Bolivian and the World Bank Standards:

#### In-Stack Emission Modeling Results

Pollutant	Emission Rate		In-Stack Bolivian Standard <sup>1</sup> Kg/10m <sup>3</sup>
	Centaur Unit Kg/10m <sup>3</sup>	Taurus Unit Kg/10m <sup>3</sup>	
PM <sub>10</sub>	0.0006	0.0006	50
SO <sub>2</sub>	negligible	negligible	9.6
CO	0.02	0.02	640
NO <sub>x</sub>	0.09	0.09	8800

1 Kilograms per 10 cubic meters of natural gas consumed

Pollutant	Emission Rate		In-Stack World Bank Guidelines <sup>a</sup> mg/Nm <sup>3</sup>
	Centaur Unit mg/Nm <sup>3</sup>	Taurus Unit mg/Nm <sup>3</sup>	
PM <sub>10</sub>	1.70	1.50	100
SO <sub>2</sub>	negligible	negligible	1000
CO	N/A	N/A	N/A
NO <sub>x</sub>	221	228	600

a From the World Bank Guidelines for Onshore Oil & Gas Development.

N/A = not applicable

### Ambient Air Quality Modeling Results

		RESULTS		REGULATIONS/GUIDELINES	
		CENTAUR 50 COMPRESSOR UNIT	TAURUS 60 COMPRESSOR UNIT	BOLIVIAN NAAQ <sup>5</sup> ( $\mu\text{g}/\text{m}^3$ )	WORLD BANK GUIDELINES ( $\mu\text{g}/\text{m}^3$ )
PREDICTED OFF-SITE NO <sub>x</sub> IMPACTS <sup>(a)</sup>	Modeled emission rate (g/sec)	10.08	11.88	N/A	N/A
	1 - hr ( $\mu\text{g}/\text{m}^3$ )	385.8	441	400.00	N/A
	24 - hr ( $\mu\text{g}/\text{m}^3$ )	154.32 <sup>(b)</sup>	176.40 <sup>(b)</sup>	150.00	200.00
	Annual ( $\mu\text{g}/\text{m}^3$ )	30.86 <sup>c</sup>	35.28 <sup>c</sup>	N/A	100.00
PREDICTED OFF-SITE CO IMPACTS <sup>(d)</sup>	Modeled emission rate (g/sec)	0.7635	0.8450	N/A	N/A
	1 - hr ( $\mu\text{g}/\text{m}^3$ )	87.69	94.11	40,000	N/A
	8 - hr ( $\mu\text{g}/\text{m}^3$ )	61.38 <sup>(e)</sup>	65.87 <sup>(e)</sup>	10,000	N/A

		RESULTS		REGULATIONS/GUIDELINES	
		CENTAUR 50 COMPRESSOR UNIT	TAURUS 60 COMPRESSOR UNIT	BOLIVIAN NAAQ <sup>5</sup> ( $\mu\text{g}/\text{m}^3$ )	WORLD BANK GUIDELINES ( $\mu\text{g}/\text{m}^3$ )
PREDICTED OFF-SITE PM <sub>10</sub> IMPACTS <sup>(f)</sup>	Modeled emission rate (g/sec)	0.0252	0.0252	N/A	N/A
	24 - hr ( $\mu\text{g}/\text{m}^3$ )	1.1577 <sup>(b)</sup>	1.1226 <sup>(b)</sup>	150.00	500.00
	Annual ( $\mu\text{g}/\text{m}^3$ )	0.2315 <sup>e</sup>	0.2245 <sup>e</sup>	50.00	100.00

Notes:

- (a) The predicted impacts do not include existing NO<sub>x</sub> background concentrations. These concentrations are not known at this time.
- (b) 24-hour average obtained by multiplying SCREEN3 1-hour impact by 0.4.  
Annual average obtained by multiplying SCREEN3 1-hour impact by 0.08.
- (d) The predicted impacts do not include existing CO background concentrations. These concentrations are not known at this time.
- (e) 8-hour average obtained by multiplying SCREEN3 1-hour impact by 0.7.
- (f) The predicted impacts do not include existing PM<sub>10</sub> background concentrations. These concentrations are not known at this time.

Based on the results of the analysis, the following conclusions can be made:

In-Stack Emission Results

- The project in-stack emissions rates for PM<sub>10</sub>, SO<sub>2</sub>, and NO<sub>x</sub> are well below the World Bank Emission Guidelines for the gas turbine sources.
- The project in-stack emission rates are expected to be well below any of the Bolivian air emission standards for PM<sub>10</sub>, SO<sub>2</sub>, CO and NO<sub>x</sub>.

## Ambient Air Quality Results

- No exceedances of the World Bank Guidelines for ambient air quality were predicted for any of the pollutants modeled.
- Regarding Bolivian Regulations, SCREEN3 predicted exceedances of the Bolivian 1-hour and 24-hour NO<sub>x</sub> NAAQS for the three TAURUS 60 turbines. The three CENTAUR 50 turbines had a predicted exceedance of the 24-hour NO<sub>x</sub> NAAQS as well. The three TAURUS 60's exceeded the 1-hour NO<sub>x</sub> NAAQS by 41 μg/m<sup>3</sup> for the scenario of three turbines in operation simultaneously. The 24-hour NO<sub>x</sub> NAAQS was exceeded by nearly 4 μg/m<sup>3</sup> for the CENTAUR 50 (three turbines operating) and by nearly 26 μg/m<sup>3</sup> for the TAURUS 60 (three turbines operating). The turbines will be equipped with low emission burners as needed to meet Bolivian air emission levels. No exceedances were predicted for CO and PM<sub>10</sub> when compared to the Bolivian NAAQS.

It should be noted that the above conclusions are based on SCREEN3 modeling results which are expected to be on the conservative side. Refined modeling techniques, such as the ISCST3 model, should result in lower levels of predicted impacts. The ISCST3 model has been designed to provide a more accurate simulation of downwash effects from buildings on a source's emissions, but requires "actual" meteorological data to determine source impacts on the air quality.

### **6.2.2 Geology, Geomorphology, Soils, and Seismicity**

Both construction and operation impacts are discussed in this section. An impact is considered significant if it could cause substantial erosion or siltation, post-construction settlement and/or loss of foundation support of facilities and/or structures, or slope instability potentially resulting in damage to facilities and/or exposure of people to danger.

The potential impacts identified related to geology, soils, and seismicity are associated with the following activities or conditions in the study area:

- Ground disturbance resulting in wind and water erosion
- Damage to project facilities from differential settlement
- Localized ground disturbance from blasting
- Damage to project facilities from geohazards
- Increased sediment in receiving waters.

#### **6.2.2.1 Geology**

The main potential effect on the geology is the disruption of rock layers or rock outcroppings. The vast majority of the pipeline alignment traverses areas covered with quaternary deposits with bedrock layers located deeper than the excavation depth, even in the river and stream crossings, where excavation will be deeper. Therefore, it is anticipated that the pipeline will not encounter rock layers throughout most of the route. However, in the Puerto Suárez area, Cambrian outcrops may surface to within the excavation depth and may require localized blasting.

#### **6.2.2.2 Geomorphology**

The pipeline will traverse mostly flat to slightly undulated terrain and no significant land form modification is anticipated. Even if localized blasting is required in the Puerto Suárez area, the effect on the geomorphology of the area will be insignificant.

#### **6.2.2.3 Soils**

Direct impacts to soil characteristics will be associated with the trench excavation and backfilling operations to accommodate the pipeline, the construction of compression stations and the upgrading of roads and storage yards. Approximately 125,000 m<sup>3</sup> of soil will be excavated from pipeline trenches. Some additional excavations will be required to upgrade the existing access roads and storage yards. During trenching and backfilling, soil layers are expected to get mixed with the organic materials; however, throughout most of the route, the organic layer is minimal or nonexistent.



Backfilling and heavy equipment passage will compact soils, affecting porosity, particle size, and other soil components. To the extent possible, trenching spoils will be employed to refill trenches and as fill material where appropriate to minimize alteration of soil characteristics. The remaining material will be placed within the pipeline corridor and graded to conform to the extent possible with natural surface contours.

**Erosion and Sedimentation.** The primary impact of the project on soils is an increase in the erosion potential in areas where soil becomes exposed by vegetation removal and areas where soils are physically disturbed by trenching, spoil piling, and backfilling. Vegetation clearing, particularly in undisturbed forested areas, exposes previously protected soils to changes in surface temperature and to direct rainfall and sunlight, therefore increasing the potential for erosion.

The exposed ground surface would consist of clay, silt, sand, and gravel. Although construction would be staged and disturbed areas minimized, the clay, silt, and sand would be susceptible to water and wind erosion when exposed to the elements. The project includes drainage and erosion control measures implemented as part of construction. Consequently, erosion would be localized and short-term and would be considered a less-than-significant impact.

Overall, erosion potential is greater in areas of high slopes, low vegetation cover, and high rainfall. Because the majority of the pipeline will traverse relatively flat areas, with low precipitation, and natural vegetation cover, it is anticipated that the potential for erosion will be low in general and controllable using appropriate erosion prevention and control techniques. Additionally, the right-of-way will disturb a very narrow strip of soil along a mostly undisturbed landscape, and the adjacent vegetation will serve as a barrier against wind (particularly in forested areas) and as a source of seeds for natural revegetation to occur.

Due to the limited rainfall in most of the project area, the recovery of native vegetation and restabilization of disturbed areas will be a slow process, perhaps requiring several years in some areas. The clearing will leave the majority of the root systems in place, which will serve both as anchors for the soil and stock material for resprouting vegetation. While the slow recovery will extend the time the soil is exposed and subject to erosion, it is anticipated that erosion will remain low due to low precipitation and slope as well as the protection against the wind afforded by the

surrounding vegetation. This is supported by observations of the existing cut line along the pipeline alignment. This 5-10 meter wide line was cut in 1993 and, particularly in the dry Chaco area between Río Grande and Isla Verde, there is no evidence of erosion even though vegetation cover is approximately 50% of the original cover.

The proposed pipeline will cross three major rivers and other minor streams. These crossings will be constructed using open-cut methods which could suspend sediment in the streams during periods of flow. Because open-cut construction of all crossings is planned to take place during periods of low flow to minimize sedimentation and facilitate construction, impacts related to increased sediment loads in rivers and streams will be temporary and localized, and are considered less than significant. In the aeolic plains associated with the Río San Miguel, the vegetation clearing will expose the soil to the wind. Here the right-of-way is less protected from the wind because the adjacent vegetation is low and herbaceous.

Portions of the pipeline will be constructed across rivers and streams and would be susceptible to scour and changing bottom profiles. Banks of streams may become more susceptible to erosion after the soils are disturbed. Slopes leading into the streams also may become more susceptible to erosion after pipeline installation. The pipeline is proposed to be installed at 1.5 m below the stream bottom to minimize the potential effects of scour and changing bottom profiles. The channel and bank contours will be restored to their original configurations to the extent feasible after pipeline installation has been completed. Breakers or riprap will be placed over the pipeline along the stream banks where necessary for erosion control. Consequently, the potential for erosion along stream banks in the vicinity of pipeline crossings is considered less than significant.

During the operation of the pipeline, additional erosional impacts to the project area will be minimal. Activities will be limited to personnel operating maintenance and inspection vehicles and equipment and limited excavations which may be required for maintenance and repairs. Movement of vehicles and support equipment will be reduced.

**Geotechnical Concerns.** Engineered fill material will be placed for building foundations and road upgrading. A geotechnical engineering evaluation will be completed prior to the final design. The foundations of the facilities and structures will be designed to accommodate potential

settlement and unstable soil conditions. In addition, spoil removed during excavation for the pipeline will be used as backfill and, therefore, off-site fill will not be required except in limited quantities in rocky areas. The installation of the pipeline will generate excess soil that would be spread evenly over the top of the pipeline alignment. The soil would be crowned over the ditch, which will compensate for possible future settlement of the backfill. Consequently, the potential for pipeline settlement is considered less than significant.

**Blasting.** Blasting may be required to remove bedrock exposed during site preparation. Blasting typically generates ground vibrations which would have the potential to induce localized slope instability. A blasting plan would be developed and implemented as part of the project. Given the relatively short-term and localized nature of this impact, it is considered to be less than significant.

#### 6.2.2.4 Seismicity

Seismic events have the potential to adversely impact structural integrity of the pipeline and related structures due to ground motion, ground rupture, liquefaction, or faulting. However, the likelihood of a moderate to large earthquake of  $M \geq 5$  impacting the project during its planned lifetime is considered low. Because of low levels of earthquake activity in the study area, it is anticipated that potential disruption of the pipeline is unlikely throughout the life of the project. The native soils are not be susceptible to liquefaction and project facilities do not cross mapped, known, active faults. Consequently, the potential for post-construction damage to project facilities resulting from a seismic event is be considered less than significant.

#### 6.2.3 Water Resources

An impact to water resources is considered significant if it could cause substantial changes in existing stream flows; lowering of groundwater levels; increased erosion, deposition, or transport of sediments; or deterioration in water quality.

The potential impacts identified related to hydrology, hydrogeology, and water quality are associated with the following activities or conditions in the study area:

- Changes in base and peak flows of nearby streams and rivers.
- Groundwater withdrawal to support both construction and operation.
- Reduction in groundwater or surface water quality.
- Increased sediment loads.

#### 6.2.3.1 Hydrology

Clearing of vegetation, trenching and storage of topsoil in the study area may result in increased soil erosion and sediment load carried by surface runoff from the disturbed areas. Any resulting impact on the sediment loads of small tributaries carrying surface runoff from these areas to nearby larger streams will be localized, and is considered less than significant. The potential increase in the sediment loads of larger rivers (i.e., Río Grande, Río Otuquis, and Río San Miguel) is considered less than significant because the relatively large volumes of water carried by these rivers would be capable of transporting the relatively small additional sediment loads from these smaller rivers and streams.

The impact of brush clearing and grading in the study area on the surface runoff generation potential of the major river watersheds is considered less than significant because the areas impacted in each watershed are a minute portion of the drainage area of the respective stream. The increase in flood flows of small unnamed tributaries in the immediate vicinity of these areas, however, would be temporary and localized and would be considered significant but mitigable.

Temporary impacts to surface drainage patterns during the construction phase will result from cut and fill grading during the improvement of access roads, compressor, workers camp, equipment staging areas and other support facilities, trenching, and improvements at river and stream crossings. Proposed construction techniques provide for restoring the original grade along the entire alignment, thus restoring the hydrology. Along the right-of-way, mounded earth will be present along those sections of the pipeline alignment involved in active construction during the time period required for trenching, emplacement and burial. To the extent possible, trenching spoils will be employed to refill trenches and as fill material where appropriate. The remaining material will be placed within the pipeline corridor and graded to conform to the extent possible with natural surface contours.

Installation of the pipeline at road crossings may result in increased erosion potential because of open cut and backfill operations. This impact, however, will be temporary and localized and considered less than significant.

The pipeline will cross a few rivers and streams which will be open-cut during construction activities, which will cause increased sediment loads, alterations in substrates, and temporary interruptions in flows in the respective streams. These impacts would be temporary and localized and would be considered less-than-significant and mitigable.

Borrow areas, which may be alongside the access road corridors or in some other areas where suitable fill materials can be obtained, will become permanent depressions which will pond water and reduce overall surface runoff to streams and rivers. Pondered surface water may also be used for stock watering purposes by colonists and may encourage the development of livestock grazing in portions of the project area. Possible benefits from these activities may include the temporary storage of surface water for use by native wildlife and the creation of habitat for fish and other animals, and aquatic plants.

Occasional temporary impacts to surface drainage patterns will result from pipeline maintenance and repair activities. Mounded earth will be present along those sections of the pipeline alignment undergoing maintenance and repair only during the time period required for excavation and repair of the pipe and reburial. The volume of additional trenching spoils generated during this phase of activity should be minimal. The bulk of the excavated material will be used for reburial. Any remaining material will be placed within the pipeline corridor and graded to conform to the extent possible with natural surface contours.

The majority of the water used for hydrotesting of the pipeline is expected to be withdrawn from surface waters. Hydrotest water withdrawal from surface water sources will be limited to protect aquatic life, provide for any water body uses, and provide for downstream withdrawals of water by existing users. The pipeline will be filled with water and hydrotested in segments of approximately 20-30 km. The maximum volume of water required for hydrotesting each segment is estimated to be about 17,000 m<sup>3</sup>. Thus, the impact of withdrawals from surface waters is considered less than significant if the withdrawals are made during average flow conditions.

The discharge will take place in uplands and will be released at a rate low enough to avoid erosion damage. Appropriate erosion control measures and volume controls will be incorporated. The impact on the local ground surface and soils is considered less than significant.

During operation, the compressor station facilities along the pipeline will be staffed with minimal personnel, who will require less than 10 m<sup>3</sup>/day of potable water to be withdrawn from groundwater sources at various locations in the area. Therefore, the impact of such relatively small withdrawals on the surface or groundwater resources of their respective areas is considered less than significant.

In the case of compressor stations, access roads, camps and other support facilities, the slight modifications to land surface topography will be permanent, and will involve the establishment of impervious surfaces in some areas. The construction of access roads through low lying areas subject to flooding will be avoided if possible but, if necessary, it will require the placement of fill materials across wide areas which may act as dams to interrupt local surface drainage patterns. Cross-drains will be constructed as necessary in critical areas to minimize alteration of hydrology.

#### **6.2.3.2 Hydrogeology**

Major activities during the construction phase of the project will require the use of potable water for workers. During the peak construction period, about 1,600 persons (two construction spreads of 800 each) will be working on pipeline construction and 120 on the construction of the first compressor station. Potable water sources for these workers will be withdrawn from wells installed at depths ranging from 100 m to 200 m. The withdrawal will occur at multiple locations as the temporary camps associated with both pipeline spreads move along the pipeline right-of-way, at the compressor station, and at the pipe storage yards. The groundwater resources of these aquifers are recharged mainly by infiltration of rainwater, and the expected annual recharge is relatively high. Therefore, impacts from groundwater withdrawal to meet the domestic water requirements of the project at various locations along the pipeline alignment on the aquifer water balance are considered less than significant.

During the peak construction period, the rate of withdrawal at the mobile construction camps and the compression station will be about 576 m<sup>3</sup>/day and 45 m<sup>3</sup>/day, respectively. These relatively small withdrawal rates will be distributed over several locations and are expected to have a less-than-significant impact on the groundwater or surface water resources in their respective regions.

Approximately 75% of the water withdrawn for water supply at the mobile construction camps (432 m<sup>3</sup>/day ) and the compressor station (34 m<sup>3</sup>/day ) will be returned as treated sanitary wastewater to the nearest subsurface waters or natural drainage. These discharges will increase the low flows of the receiving streams, which would be considered a beneficial impact. The quantities of these discharges are small fractions of the anticipated flood flows of the receiving streams. Therefore, the impact on peak flows would be considered less than significant.

The specific capacity of existing wells in the vicinity of the pump stations in the San José de Chiquitos, Roboré, and El Carmen areas ranges from 5 to 30 m<sup>3</sup>/hr. The average domestic water requirement at each camp during operation is estimated to be about 43,000 lt/hr. Therefore, groundwater pumping at the prevalent rates in the area would be sufficient to meet project requirements without significant drawdown. Impacts to groundwater levels resulting from well pumping are considered less than significant.

### 6.2.3.3 Water Quality

Construction in the pipeline right-of-way and cleared areas for compressor stations, road and storage yards, and construction camps has greater soil erosion potential than in uncleared and undisturbed areas. Increased erosion would result in greater sediment loads in surface streams during storm events. The impact of this increased loading is considered less than significant both on relatively small tributary streams in the immediate vicinity of the disturbed areas and on the respective major streams or rivers.

Approximately 432 m<sup>3</sup>/day of treated sanitary wastewater will be discharged to surface streams from various sources at different locations. The resulting water quality impacts on the receiving streams will be localized and are considered less than significant.

During operations, the quantities of treated sanitary wastewater discharged to surface streams will be negligible. The water quality impacts of these discharges will be localized and less than significant at the point of discharge and less than significant beyond the mixing zones.

Pipeline construction will require mobilization of large numbers of construction personnel, various types of support facilities, truck and trailer-mounted equipment and support vehicles to the pipeline corridor and support areas and their maintenance in these areas for periods of weeks to months. Potential impacts to surface water and groundwater quality may result from the mobilization and operation of equipment, fuel and materials storage and transfer operations, equipment maintenance activities, operating accidents and waste disposal.

Potential releases from the above sources could include gasoline and diesel fuel, lubricating oil, hydraulic fluid, paint and various types of solid waste such as used and broken equipment, drums and other types of containers, as well as ordinary solid wastes. Additional sources of contaminants resulting from the presence of construction crews in the project area include the generation of sanitary waste and various types of ordinary solid waste such as cooking waste, discarded food and other miscellaneous waste materials.

These contaminants may be spilled or disposed directly into surface water bodies or on the land surface in drainage areas, or may leach through the surface soils to impact shallow groundwater aquifers. Contaminants released into surface water bodies and/or shallow groundwater aquifers from the above sources could include, but not necessarily be limited to the following:

- Oil and Grease (lubricants, etc.);
- Volatile Organic Compounds (VOCs) and Semivolatile Organic Compounds (SVOCs) from fuels, hydraulic fluids, anticorrosives, paint, etc.;
- Metals (contaminants in used lubricating oils, paints, etc.);
- Bacterial products from sanitary wastes; and,
- Increased Total Dissolved Solids (TDS) and Total Suspended Solids (TSS) from surface runoff from impacted areas.



The discharge of waters used in hydrostatic testing of the pipe may also include some of the above contaminants in addition to turbidity. Discharge into containment areas constructed of filter bags or erosion control barriers in accessible upland areas will minimize water quality impacts.

Additional impacts to surface water quality may result from right-of-way clearing, trenching and backfilling activities. Erosion and sediment transport from unvegetated right-of-way areas may enter streams and rivers or associated wetlands areas. Trench excavation and backfilling using the cut and cover construction methodology are expected to result in a temporary elevation of turbidity levels in streams and wetlands crossed by the pipeline. However, due to the nature of the pipeline construction process, any resultant turbidity should be limited to only a few days at a time for each crossing area.

Potential impacts of turbidity will vary depending on the flow characteristics of the area. In low or no flow conditions, turbidity can be largely contained within the proposed right-of-way with little effect on adjacent areas. In flowing water bodies, there is a potential for construction-related turbidity to be carried into downstream areas. The implementation of erosion and turbidity control measures during pipeline construction should minimize impacts to adjacent water bodies.

Solid waste management does not currently exist in much of the project area. Typically, garbage, litter, and trash are dumped near housing facilities or into streams and rivers. Human wastes are treated similarly. At low population densities, this practice may be only aesthetically undesirable, and may not pose a significant threat to water quality. However, with larger volumes of waste material at work camps and other areas where workers will occur in high numbers, adverse water quality impacts may result.

Domestic wastewater generated at work camps, pipe storage yards or other areas with large number of workers must be treated prior to disposal. Extended aeration package plants or conventional septic system drainfields will be constructed to provide treatment. Treated effluent will be discharged to upland areas where possible. If discharge of treated effluent occurs to receiving water bodies, bacteria and nutrients in the receiving waters will be elevated at the point of discharge. Impacts are not expected to be significant due to the short construction period and relatively small volume of discharge anticipated. Sanitary waste facilities constructed for the

project will be dismantled and removed following project construction to prevent development of additional population centers.

Solid waste management practices will include at a minimum containment of solid waste and debris at receptacles located at appropriate intervals. The waste management plan may include establishment of a sanitary landfill at work camps in accordance with Bolivian regulations. Proper handling of solid waste will prevent water quality impacts to surface and ground waters.

#### **6.2.4 Noise and Lighting**

The location of camps and construction activities along the pipeline alignment and the compressor station could affect wildlife and human settlements directly by disturbing local individuals or wildlife populations due to construction noise, lighting, and general habitat disturbance.

### **6.3 IMPACTS ON THE BIOLOGICAL ENVIRONMENT**

This section addresses potential impacts on various biological resources from construction, operation, and maintenance activities associated with the project. The duration and magnitude of impacts vary according to project activities (construction versus operation) and the various elements of the project (export pipeline, pump stations). Some impacts would require mitigation measures to reduce impacts to less-than-significant levels. Impacts are discussed in terms of:

- Vegetation
- Fauna
- Species of Special Concern
- Protected Areas

#### **6.3.1 Vegetation**

Construction activities, including clearing and grading, trenching, backfilling, hydrostatic testing (during discharge of water), and final cleanup, will cause temporary and permanent alteration of vegetation within the pipeline right-of-way. Woody upland vegetation will be cut at ground level

and, in some cases, stumps will be removed to allow for movement of construction equipment and trench excavation. Throughout much of the proposed pipeline corridor, vegetation was cleared in 1993 in preparation for construction activities. Many older cut lines originally established for seismic work criss-cross the area between the Río Grande and Río Parapetí. The effects of the previous clearing activities on vegetation are currently visible to varying degrees along the route. Additional impacts will result from expansion of the cleared area to a width of 30 meters for pipeline construction.

The route crosses predominately upland low forest, tall scrub, and savannah areas. The pipeline construction activities will also affect medium forest areas (both dry and wet) and a small area of riparian forest associated with the Río Parapetí system. Open savannahs and some pasture areas will also be encountered along the route.

Herbaceous and shrubby vegetation will be temporarily impacted by construction activities. However, in most areas of the pipeline corridor, native herbaceous and shrubby species are expected to revegetate naturally following completion of pipeline construction. Over time, native species are expected to return. Due to the nature of the soils and dry climatic conditions, revegetation of the pipeline corridor in the dry Chaco may take longer than in the remainder of the corridor. In this area, recovery of vegetative cover from the previous survey cut has been slow. The actual rate of revegetation along the pipeline route will vary depending on local climate, soil type, and nature of native vegetation.

Provided that natural contours are maintained and hydrologic characteristics re-established following pipeline construction, wetland vegetation is expected to return within one growing season. Aquatic emergent and submergent species may be adversely affected by silt deposition and turbid water during trenching activities or discharge of hydrostatic test water, but will return quickly following completion of construction activities.

For pipeline maintenance activities, trees in forested areas removed during construction will not be allowed to re-establish within the permanent pipeline right-of-way. In both wetland and upland areas, the pipeline will result in the permanent loss of the forested canopy in the 17-meter wide permanent corridor. A five-meter corridor was previously cleared. In wetlands areas, wetland

species are expected to return rapidly and wetland functions will not be significantly affected except for the canopy loss. Trees will be allowed to revegetate in the temporary construction areas.

### 6.3.2 Fauna

Potential impacts to indigenous wildlife are expected to result from construction of work camps and access roads as well as all construction tasks. Both direct and indirect effects will occur. Potential impacts affecting animal populations generally include the following:

- Direct loss of individuals from construction activities or increased hunting pressure due to new or improved access into a previously remote area.
- Direct loss of important habitat elements such as breeding, foraging, and cover areas.
- Direct disturbance to or loss of wildlife habitat.
- Displacement of individual animals during construction or maintenance.
- Fragmentation of habitats due to construction and maintenance of the pipeline right-of-way.
- Temporary disruption of movement patterns of animals across the right-of-way.

The most substantial wildlife impacts associated with the project will be the conversion of habitat in the permanent maintenance corridor. Temporary loss of habitat will occur in the non-forested portions of the construction right-of-way. Along portions of the right-of-way which were cleared in 1993, additional impacts will be minimal, because some impacts to faunal species associated with effects on vegetative cover have already occurred in the previously cleared corridor. Some loss of habitat will occur due to construction of the compressor stations, work camps, and other associated facilities.

Additional impacts on wildlife will include disturbance, displacement, and mortality during construction. Clearing of vegetative cover in the right-of-way will affect the nesting and foraging habitat for some wildlife species. Mobile species will temporarily move out of the pipeline corridor. The loss of forested canopy within forested areas will result in impacts to wildlife species utilizing this stratum of the forest, but this impact is expected to be minimal due to the narrow permanent right-of-way strip.

Other impacts to wildlife include effects resulting from noise generated by machinery and/or construction workers and potential contamination effects should a spill occur. These types of impacts should be temporary and will cease at the end of construction. Noise is considered to be of concern primarily during breeding or nesting periods.

Secondary impacts to wildlife may occur as a result of project construction. Without the application of specific measures to prevent it, hunting pressure would be expected to be heavy during construction and could have significant impacts on important wildlife species such as tapir, peccaries, and jaguars. Hunting will be of special concern in the area around the work camps due to the concentration of construction workers in areas previously undeveloped. Following construction, increased access along the pipeline corridor may allow continued hunting pressure on the abundant wildlife in the area.

As a result of clearing and erosion, sediments and organic material may enter nearby waterways resulting in elevated turbidity levels, sedimentation and shoaling of rivers systems or smaller water bodies. Physical changes resulting from heavy sedimentation may affect local hydrology. Implementation of appropriate construction and management techniques are expected to minimize turbidity and sedimentation in adjacent waters.

Aquatic species in the area of the Pantanal, floodplains, and major river systems of the Río Grande, Río San Miguel, and Río Otuquis are expected to be adversely impacted by construction activities generating high turbidity. However, such impacts are expected to be short-term. Fish species and mobile reptilian and mammal species will likely move out of the area temporarily and will return following completion of construction activities. Non-mobile species including benthic invertebrates and any bivalves will be eliminated in the construction corridor, but are expected to recolonize impacted areas quickly from surrounding areas. The Río Grande is naturally high in turbidity, and temporary increases in turbidity are not expected to have adverse impacts on animal species in this river.

Hydrocarbon spills and the introduction of other chemicals such as pesticides and herbicides into water bodies and wetland areas could have a severe impact on aquatic resources. Fuels and lubricants are generally lighter than water and float on its surface dispersing quickly and widely

thus potentially impacting many organisms. With implementation of spill prevention and containment procedures which will be implemented during project construction impacts to aquatic fauna are expected to be minimal and localized.

Relative to the extent of undisturbed wildlife habitat in the study area, the effects of the project are expected to be negligible. The main concern is the potential increase in hunting for large mammals.

### 6.3.3 Species of Special Concern

Impacts to terrestrial and wetland/aquatic plant and animal species identified as species of special concern are expected to be minimal and temporary. Temporary displacement of some species from the construction area will occur, and for some species movement across the right-of-way will be hampered during construction activities. After completion of construction, however, the right-of-way will be allowed to naturally revegetate. Affected species of special concern are expected to return to the right-of-way. Impacts to the population of protected plant species are expected to be insignificant.

Adverse effects of pipeline construction to various listed species will be associated with removal of the canopy in forested areas. Birds which depend on forested habitat for roosting, nesting, or feeding such as the *Paraba roja*, *Amazona aestiva*, and *Paroaria coronata* may realize a slight reduction in availability of suitable habitat. However, the permanent corridor should have an insignificant effect on these species. No evidence of nesting by avifaunal species of special concern was observed within the proposed pipeline corridor during field investigations.

Those species which require or prefer open herbaceous/shrub plant communities may benefit, at least temporarily from the establishment of the right-of-way. Such species include tortoises, terrestrial raptors, wading birds and reptiles and amphibians.

As discussed above, hunting pressure on wildlife including species of special concern is expected to be increased particularly during pipeline construction and in the vicinity of the work camps. Of primary concern are effects on mammalian species such as *Tapirus terrestris*, *Tayassu tajacu*,

*Tayassu albirostris*, and *Catagonus wagneri*, of the humid forests of the Chaco region and *Blastocerus dichotomus* and *Pteronura brasiliensis* of the Pantanal area. Other species including the large cats, *Felis concolor* and *Panthera onca*, may also be affected by increased hunting pressure during pipeline construction activities when large numbers of workers are in the area. Additionally, reptilian species such as *Geochelone carbonaria*, *Caiman yacare*, and *Tupinambis teguixin* may be affected by increased hunting pressure. Many of these species are hunted for food. Hunting will be strictly prohibited for anyone associated with the pipeline construction to mitigate impacts to the wildlife populations.

#### 6.3.4 Protected Areas

Project activities will be conducted within two protected areas: the Integrated Management Area of the Gran Chaco National Park and the Historical National Park Santa Cruz La Vieja. Direct impacts to areas within the Integrated Management Area will be limited to clearing the right-of-way, as discussed above. Indirectly, the possibility of increased hunting pressure within the park boundaries exists, and specific measures will be implemented to prevent it. The access road from San José de Chiquitos traverses the Santa Cruz La Vieja park. The park will be affected by road improvement work, but it may also be favored by the improved access which may promote tourism into the park. Other areas of interest for their resources and tourism potential within the study area include the hot springs at the Río Aguas Calientes' headwaters, the forested wetlands associated with the Río Tucavacas south of Naranjos, and the Tacuaral marsh, including the connection between the Bañados de Otuquis and the Pantanal at the Cañón de la Victoria. These areas will not be directly impacted by construction activities,

### 6.4 IMPACTS ON THE SOCIOECONOMIC ENVIRONMENT

The project's impacts on the human environment would originate from the following sources:

- Land Use Aspects
  
- Social Aspects
  - Changes in population

- Impacts on public health and safety
  - Improvements in education and training
  - Education and training
  - Effect on Indigenous people
  - Cultural and archaeological resources
- Economic Aspects
    - Project Revenues (Total, Local Taxes, and Central Government Taxes, Public Participation Law, Government Revenues)
    - Employment (hiring and wages, labor, and accommodations)
    - Improvements in Infrastructure
    - Local business opportunities

#### **6.4.1 Land Use**

Changes in land use are expected to occur as a result of the project implementation. However, the Project Sponsors plan to reinstate as much land as possible throughout project development, construction and operations. Conversion of land from existing uses (e.g. farming, grazing, fallow) has the greatest potential to create adverse social and economic impacts to rural households. Three levels of land use impacts will potentially occur. In order of increasing severity they are:

##### **6.4.1.1 Temporary Land Use Change**

Temporary conversion of land to support pipeline and facility construction may result in the loss of one to two years' plantings, but no displacement of households is anticipated. Construction of the pipeline will necessitate the temporary clearing of a strip of land along the pipeline route and at various other locations (for use as storage yards, etc). The affected area along the pipeline route will be approximately 1,680 ha (represented by a 30 m wide strip, 560 km long), while the area off the pipeline route that will be temporarily affected is not expected to exceed 60 ha. Not all of this land will be under human use at the time of construction; however, the impact of



temporary changes in land use during the construction period is considered to be significant but mitigable.

#### **6.4.1.2 Permanent Land Use Change without Resettlements**

Permanent loss of a portion of land holdings (including fallow and bush lands) at facility sites may impair, but not eliminate, the economic viability of a household. The land requirements for the project will generally result in the loss of only a portion of the total land holding of any particular household or individual. The limited extent of land loss will be such that adjustments can be made to ensure that the economic viability of the household or individual may be maintained without the need for their relocation. Such an impact is considered significant but mitigable.

#### **6.4.1.3 Permanent Land Use Change with Resettlements**

There is not expected to be any permanent loss of land that results in household resettlement. During preliminary design of the project, the facilities and pipeline corridor were sited to avoid populated areas. As a result, no requirement for involuntary resettlement has yet been identified. However, the uncertainties of population movements prior to the commencement of construction and the refinement of routing and site selection that will continue as the project design evolves, mean that some requirement for resettlement is possible, although the overall number of displaced households would be minimal. No displacement of households is anticipated, therefore, the potential impact is considered less than significant.

#### **6.4.1.4 Indirect Land Use Impacts**

In addition to the above impacts that are direct consequences of the development of the project, the potential exists for indirect impacts as a result of changes in land use. A potentially significant impact is the increase in value of land near project facilities as a result of factors such as improved access to that land, proximity to the new market for goods and services represented by manned project facilities such as construction storage yards and compression stations. An increase in land value would be considered a beneficial impact if the traditional owner or user of the land retained ownership or usage rights. However, in view of the informal nature of such land tenure this

increase in value could lead to misappropriation of the land in question to the disadvantage of the customary or traditional owner or user of the land. This would be considered a significant but mitigable impact.

Pressure may also exist to utilize portions of the right-of-way as a trail or road, which may promote illegal trade, increase mobilization, and colonization pressure. However, the project does not intend that the right-of-way be used as an access road and will provide measures to prevent such use. The changes would result in a variety of both beneficial and adverse impacts, sometimes affecting different groups at different times. The nature of impacts would vary with project activities (i.e., construction, operations, abandonment) and locations of project elements (i.e., facility, pipeline, roads, etc.). Some adverse impacts would require mitigation measures to reduce their severity to less-than-significant levels.

## **6.4.2 Social Impacts**

### **6.4.2.1 Population**

The study area will experience a small and temporary increase in population during the construction phase due to the influx of approximately 1,600 workers. While workers will be housed in camps along the right-of-way, it is expected that they will visit the main population centers, such as San José de Chiquitos, Roboré, and Puerto Suárez, in search of relaxation and entertainment during work breaks. A 800-person camp will be located in El Carmen and the presence of the working crew will be continuous, adding to the demand for services in this town. Due to the additional temporary demand for goods and services associated with the pipeline workers, it is possible that small scale merchants may relocate temporarily from other areas to nearby towns. It is unlikely that the project will directly promote any permanent increase in the population of human settlements located along the pipeline alignment.

### **6.4.2.2 Public Health and Safety**

The construction phase of the project will cause a significant but temporary increase in population due to construction-related employment and other supporting activities. With the temporary influx

of population, there may be a slight increase in contagious diseases. Also, the vast majority of the incoming workers are likely to be males who will join the project alone and may look for entertainment in the nearby towns. This may result in an increase in the occurrence of sexually transmitted diseases.

Other health problems which are often not highly visible but may have long-term implications can be caused by parasitic diseases such as malaria. In addition, the influx of hundreds of workers into a remote work area has the potential to alter the natural disease immunity. Workers who have developed resistance to local strains of malaria may relocate for work along the pipeline. They mistakenly can be presumed malaria-resistant and not entered into chemoprophylaxis programs. The workers would then be vulnerable to outbreaks of malaria from specific local strains of malaria. Malaria resistance is highly local and small geographic shifts of either workers or mosquitos can have large public health impacts.

Heavy equipment traveling along dirt roads will temporarily increase noise and air pollution levels, potentially affecting surrounding communities. The assimilation of large numbers of workers selected from local communities brings with it the potential for hiring worker subgroups from various community groups, potentially creating camp conflicts and safety concerns. Vector control measures could potentially impact local health status, depending on the extent of chemical spraying. Consequently, health related services, which are deficient in the study area, may face an increased demand, which could become critical in the event of an outbreak of contagious diseases.

As part of the project, an occupational health and safety program will be developed to address health and safety concerns of project personnel. The program includes medical (clinical) and industrial hygiene components. A medical director is planned to be based in Santa Cruz, Bolivia, to assist with patients from operations facilities. Medical facilities located at Santa Cruz, Roboré, El Carmen, and Puerto Suárez would serve as the major trauma care and inpatient treatment centers. Preventive health measures will also be included in the program. With implementation of this program, public health and safety impacts are considered less than significant.

#### **6.4.2.3 Education and Training**

Bolivian and expatriate project personnel will receive training in safety measures, environmental protection, and basic work practices. Comprehensive training will be provided to craftsmen in their respective crafts to develop entry level and mid-level construction workers, and technical training will be administered to employees as required to prepare them for their assignments. Supervisory personnel will receive training in safety, human relations, planning and scheduling, problem solving, and decision making. This education and training would be considered a beneficial impact of the project on the Bolivian national work force.

#### **6.4.2.4 Indigenous Peoples**

The three groups of indigenous people that are known to reside within or close to the study area and are likely to be impacted by the project are the Ayoreos, Chiquitanos, and Izozeños. The Ayoreos inhabit the areas located along the Santa Cruz-Puerto Suárez railroad. The Chiquitanos mainly reside in areas located in the vicinity of San José de Chiquitos. The Izozeños inhabit along both flanks of the Parapetí River in the area of the Bañados de Izozog. These groups' livelihoods depend on the forest and its faunal and floral resources. They live separately from, but interact with, the dominant society in the area from whom they are socially and culturally different.

The project would potentially impact the indigenous peoples at three levels:

- The forest resources will be reduced as a result of limited clearing associated with the construction of the pipeline, which may also facilitate further forest exploitation for hunting and logging. Given the small area to be cleared, this impact is considered less than significant.
- Opening up previously inaccessible areas of new forest could have the further impact of more forest clearing for agricultural purposes, thus reducing forest areas available for indigenous use. Because the pipeline and access roads will use existing corridors, this impact is considered less than significant.

- Some Indian villages or camps might be overlooked because of their small size and the air of impermanence associated with them. Because impacts to undisturbed areas will be minimal, it is unlikely that small villages will be overlooked. This potential impact is considered less than significant.

With the establishment of the Gran Chaco National Park, the core territory of indigenous groups has been given legal protection. The project will provide opportunities for the implementation of portions of the management plan of the park. The project may also bring more attention to the area and may indirectly promote colonization, which would in turn represent conflict with the indigenous populations. However, since the right-of-way was partially cleared in 1993, no evidence of colonization has been detected. Therefore, these potential impacts are considered less than significant.

#### **6.4.2.5 Cultural and Archeological Resources**

No significant potential impacts to cultural, archaeological, and historical resources have been identified. No archaeological resources have been identified along the pipeline alignment or along access road corridors based on literature research. However, the existing access road from San José de Chiquitos to the pipeline right-of-way traverses the Historical National Park Santa Cruz La Vieja. Impacts to the park related to the increase traffic in this existing road are likely to be minimal.

#### **6.4.3 Economic Impacts**

##### **6.4.3.1 Project Revenues**

The project will provide substantial direct financial revenues to the Republic of Bolivia through the sales of 8 million cubic meters of natural gas per day in the first year up to 16 million cubic meters per day in year eight. These sales will generate revenues for the central government (through corporate taxes), the regional governments of gas-producing areas (through local taxes locally known as regalías), the municipalities (through the new Law of Public Participation), and the retirement funds (through the capitalization shares). The central government will generate

additional indirect revenues from employee income taxes resulting from project-related employment and aggregate value taxes (IVA in Spanish) on business transactions completed as a result of the construction and operation of the project. This increase in governmental revenues associated with the project would be considered a beneficial impact that would extend over the life of the project.

#### **6.4.3.2 Employment**

**Hiring and Wages.** The project will employ approximate 500 local non-specialized workers for the construction activities. Preliminary estimates of total personnel requirements indicate that approximately 1000 jobs would be held by Bolivian nationals during peak construction of the pipeline, the installation of the first compressor station, construction of the associated housing and support facilities, the port and railroad operations, and the upgrading of the access roads. Wages for these workers over the one year construction period are projected at approximately U.S. \$4.8 million. The provision of wages and other benefits to Bolivian nationals would be considered a beneficial impact of the project. While positive, this effect will be temporary and will cease after construction is completed.

Increased employment during construction will be followed by a retraction in incomes as workers are released. This potential boom-bust syndrome would be considered a significant but mitigable impact. However, it is expected that a limited number of the Bolivian construction work force will be recruited as operations and maintenance personnel. The Project Sponsors will implement an aggressive nationalization plan to maximize the speedy replacement of expatriates with nationals. This approach would result in a beneficial impact to the local economy.

During abandonment, employment of Bolivian nationals would decrease. This decrease in employment and the effect on the local communities would be considered a less-than-significant impact, given the low number of operations personnel and the ability of the local communities to absorb these workers.

**Labor Recruitment.** The availability of employment during the construction and operations phases of the project is a major expectation of the local population. The equitable distribution of

jobs among people in the study area is a real concern of the local labor force. Residents of villages in and near the pipeline right-of-way are interested in securing jobs with the project to supplement their incomes. The primary concern of residents is that no single group would be favored over another, and that outsiders (Bolivians as well as foreigners) would not be recruited for work that residents are capable of performing. It is recognized that expatriate personnel would fill many of the supervisory, technical, and skilled craft jobs on the project; however, most of the manual labor work is expected to be allocated to local laborers. Labor recruitment with the potential for inequitable distribution of jobs would be considered a significant but mitigable impact.

**Workers Accommodations.** Housing will be required for both the construction and operations phases of the project. During construction of the fixed facilities, such as compressor stations, the local Bolivian work force will be responsible for its own housing, and transportation will be provided for the workers. For those Bolivian nationals living beyond a reasonable bussing distance, accommodations will be provided. Expatriates will be housed in construction camps. For pipeline construction, housing will be provided for both Bolivian nationals and expatriates. Given the bussing and accommodation provisions of the project, the need for housing during construction is considered a less-than-significant impact.

During operations, some Bolivian workers (operating and maintenance work force) will require permanent housing within commuting distance of the compressor stations. It is expected that Bolivian workers would assimilate into nearby towns. Given the relatively low number of operations personnel and the ability of local towns to accommodate them, the need for housing during operations is considered a less-than-significant impact. During abandonment, the reduction in labor force may result in a minor surplus of housing in local villages and towns. This housing surplus should be absorbed by the community and is considered a less-than-significant impact.

#### **6.4.3.3 Infrastructure**

To facilitate movement of materials for the construction and operation of the pipeline and compressor stations approximately 508 kms of existing roads will be upgraded, and no new road sections are anticipated to be constructed for the project. Additionally, replacement and widening

of some existing bridges, installation and construction of bypasses, and various other infrastructure upgrades would be undertaken for the project.

Road upgrades associated with the project will ease transportation problems for local residents and help reduce transportation costs associated with imports and exports. Upgrade and maintenance of roads during construction of the project would be considered a beneficial impact. However, increased traffic flow associated with infrastructure upgrades may result in an increased accident risk to people and animals. This increased risk is considered a significant but mitigable impact.

#### **6.4.3.4 Local Business Opportunities**

Goods, services, and some additional infrastructure will be required to support construction and operations personnel. A portion of these procurement can be purchased from local markets. It is anticipated that most goods required for the project will be purchased in Santa Cruz and Corumbá. However, pipeline workers will have demands for retail items such as food, cigarettes, and clothing, as well as services mainly related to health and entertainment. To spread the project's economic effects to local communities, the Project Sponsors are developing plans to encourage local business development so that goods and services can be purchased locally and infrastructure made available. This purchase of local goods and services will also create indirect market development for foodstuffs, construction materials, and transportation. The purchase of local goods and services would be considered a beneficial impact of the project.

While most of the resources and supplies for the project will be purchased in Santa Cruz and Corumbá, a moderate increase in the demand of goods and services from the towns along the railroad is likely. Based on projected manpower loading for the project, local goods and services expenditures for camp operations during the one year construction period are expected to be on the order of US\$ 5 to 10 million. Increased demand for goods and services may cause prices to increase in rural areas. While higher prices may benefit suppliers, rural residents would be affected adversely by the inflationary prices. This inflation would be considered a significant but mitigable adverse impact to local residents.



In addition, local suppliers may increase production to maximize benefits from the proposed project's purchasing of local goods and services. Purchasing would decline as construction is completed. This decline may create a potential boom-bust syndrome for local suppliers, which is considered a significant but mitigable impact.

During operations, purchasing activity should be somewhat constant, although at a lower level than during construction. The local economy should have no difficulty meeting the project's requirements and the anticipated infusion of monies to local and regional markets is considered a beneficial impact.

After abandonment, the project demand for provisions and procurement would disappear. However, it is expected that the regional economy would have developed sufficiently to accommodate the change. As a result, abandonment would have a less-than-significant impact on the local and regional economy.

## **6.5 RISK ASSESSMENT**

### **6.5.1 General**

Gas transmission pipelines have a history of reliability and safety compared to other transportation and shipping systems. The Bolivia to Brazil pipeline project is being routed, designed, and constructed to standards equal to or above those of other modern pipelines built in the world. Operation, maintenance and emergency procedures are being designed to reduce the potential for interruption and emergencies. Through these measures, the proposed gas transmission pipeline will provide safe and reliable transport of needed clean burning fuel.

The reliability and safety of the proposed Bolivia to Brazil pipeline system will be affected by natural occurrences as well as acts of man. This section discusses the risk assessment of the project covering the following topics:

- the safety performance of gas pipelines based on statistical data available for pipeline projects located in the U.S. Data from the U.S. were selected for this analysis because of the abundance and quality of statistical information readily available in this country.
- the assessment of pipeline hazards based on statistical data and the specific known potential hazards for this project.
- the means which will be incorporated into the project to control the inherent risk levels of gas pipeline systems.

A project contingency plan is presented in Appendix D.

### **6.5.2 Safety Performance of Gas Pipelines in the U.S.**

In 1989, there were over 1.6 million miles of natural gas pipelines in the United States (U.S. Department of Transportation, 1989). Records of reportable failure or leakage including damage cost estimates, injuries and fatalities have been kept by the U.S. Department of Transportation since 1970 (American Gas Association, 1990). However, reporting requirements were changed in 1984 so that it is difficult to combine the data before and after that date. Data from 1984 to 1989 have been used along with other sources as the basis for the analysis presented in this section.

As shown by the U.S. Statistics, pipelines are one of the safest modes of transportation available (U.S. Department of Transportation, 1989). Based on the estimated 1989 gas pipeline mileage and the 1984-1989 performance data referenced above, the annual occurrence of gas pipeline leaks is less than one per 6,500 miles and the annual occurrence of rupture is less than one per 10,000 miles. Table 6.3 lists the fatalities from various transportation modes for 1989. As shown in this table, pipelines have the lowest annual fatality rates (0.08%) of all listed modes.

**TABLE 6.3****1989 TRANSPORTATION FATALITIES\***

<u>Transportation Mode</u>	<u>Fatalities</u>
Passenger Cars	24,929
Trucks and Vans	9,365
Motorcycles and Bicycles	4,147
Pedestrians	6,525
Other Highway	668
Aviation	1,158
Marine	991
Rail	601
Recreation	896
Transit	601
Other Commercial	95
Pipelines	39

\* Data from NTSB Digest Vol. 9, No. 5

Of the 39 reported fatalities associated with pipelines, gas transmission lines accounted for only 22, which represents less than 0.05% of the total transportation fatalities.

A comparison of gas transmission and other pipeline fatalities to other accidental fatalities is shown in Table 6.4. Compared to total accidental deaths, the number of pipeline fatalities falls to an even lower rate, less than 0.03% of the national total.

**TABLE 6.4****1989 NATIONWIDE ACCIDENTAL DEATHS\***

<u>Type of Accident</u>	<u>Fatalities</u>
Motor Vehicles	46,900
Falls	12,400
Poisoning	6,500
Drowning	4,600
Suffocation by ingested object	3,900

Firearms	1,600
Other**	14,200
Pipelines	39
Gas Transmission Pipelines ***	22

\* All data, except as noted, are 1989 statistics from "Accident Facts" - 1990 Edition, National Safety Council, Chicago, IL.

\*\* Includes Medical Complications, Air Transportation, Machinery, Mechanical Suffocation, Struck by Falling Objects, etc.

\*\*\* U.S. Department of Transportation, 1989

### 6.5.3 Assessment of Pipeline Hazards

In assessing the hazards of gas pipelines, the history of pipeline incidents reporting to the U.S. Department of Transportation provides direction. These data for total incidents, ruptures, and leaks, for the period from mid 1984 through 1989 (American Gas Association, 1990), are summarized in Table 6.5. As indicated in this table, the two most significant hazards to gas pipelines are outside forces and corrosion. Less significant is the effect of natural hazards and fire. The data from the 1984-1989 report breakdown the outside forces and corrosion causes even further. These further breakdowns indicate that 89% of the outside force incidents for on shore lines are caused by construction or earth moving equipment whereas the remaining causes are related to natural hazards and "Other". The further breakdowns also indicate that over half the incidents in on shore lines are related to external corrosion.

**TABLE 6.5**

**INCIDENTS, RUPTURES, AND LEAKS PERCENTAGE BY CAUSE  
1984-1989<sup>2</sup>**

<u>Cause</u>	<u>Incidents</u>	<u>Ruptures</u>	<u>Leaks</u>
Outside Forces	39	30	34
Corrosion	23	37	30
Material Defects	9	14	9
Construction Defects	6	6	8
Other*	23	12	19

\* More than one third of the "Other" cause is due to fire, which is more than twice as high as the next largest sub-cause under "Other". The remaining sub-causes are scattered and are a small part of the overall.

For the Bolivia to Brazil pipeline project, the anticipated hazards can be summarized as follows:

- Outside forces (construction or earth moving equipment)
- Natural hazards (earthquake, flooding, Differential Settlement)
- Corrosion

The means of controlling the risks associated with these potential hazards are discussed in the following section.

#### **6.5.4 Risk Control**

##### **Outside Forces**

As indicated in the previous sections, buried pipelines have an excellent record of reliability and safety in relation to outside forces such as construction and earth moving equipment. To increase project safety, operating procedures will be developed for pipeline marking to provide for signs along the Bolivia to Brazil pipeline right-of-way. The signs will alert the public to the existence of the pipeline and provide information on contacting the appropriate party to anyone planning excavation or other potential disruptive activities in the area of the pipeline. On notification, local

pipeline crew members will mark the location and depth of the pipeline to avoid accidental damage.

### **Natural Hazards**

The area of the Brazilian Shield geologic formation, where the project will be located, has been characterized by a low level of seismic activity based on readily available information (see Section 4.3.3). By its design and construction, the Bolivia to Brazil pipeline will be placed below the level of the effect of such natural hazards as tornadoes and most lightning. The proposed burial will be sufficient to resist any but unusually severe flooding. River, stream and wetlands crossings will be built as open cuts and the pipe will be weighted to compensate for buoyant forces. For standard in ground installation, since the pipeline gas normally weight less than the displaced soil, the potential for settlement is small. Consequently, the potential risks associated with natural hazards are considered relatively low.

### **Corrosion**

The proposed Bolivia to Brazil pipeline will be designed, constructed, operated, and maintained in accordance with internationally accepted safety standards intended to ensure adequate protection for the public from natural gas pipeline failures. In addition to compliance with international requirements for corrosion protection, Operating Procedures will be written for procedures on corrosion protection. Both a high quality coating and an impressed current cathodic protection system will be installed as a part of the pipeline construction to mitigate this hazard by inhibiting corrosion. In addition, operation of the system under those procedures includes protection of the line, the protection system, and the operating of the protection systems. With the proposed protection, the potential risks associated with corrosion of the pipe are considered relatively low.

### **Other Safety Considerations**

Along with other industry standards, the Bolivia to Brazil project is being designed according to ASME B31.8 (American Society of Mechanical Engineers Code for Pressure Piping). This Code considers population density along the project route and requires additional safety features in the

more populated areas. Population density, or class location, is categorized into four classes depending on the number and type of structures existing within an specified area of the pipeline centerline. The code incorporates design and construction requirements which compensate for the higher risks associated with the event of an unlikely pipeline rupture in the more densely populated areas. As part of these requirements, pipe wall thickness, minimum pipeline burial depths and hydrostatic testing requirements all increase with increasing population density, or with the class location.

The ASME B31.8 Code adopted for the project also requires the installation of mainline block valves capable of isolating sections of pipeline on new transmission systems. The maximum spacing of these mainline valves is specified by class location in the code, and for the Bolivia to Brazil pipeline project, the maximum spacing is specified to be 32 km. The incorporation of these valves will allow local crews, established as part of the operating company, to isolate a problem area by closing the nearest valves in the event of an emergency situation. Once the problem area has been isolated and the supply source has been separated, the natural gas within the section will eventually deplete, and repairs can be made by operating crews to restore service to the pipeline customers.

As an additional safety feature, some mainline valves will be equipped with devices which will automatically close the valve under certain conditions. These devices will constantly sense the system to trigger the closure of the subject valve in the event of an excessive rate of drop in the pipeline pressure or an excessive low pressure, conditions that can indicate a leak or a rupture in the pipeline. The compressor stations will be equipped with an emergency shut down system which, in the event of an emergency, will isolate the station piping from the mainline, and will vent all gas contained in the station piping. The emergency shut down system will allow activation either manually, or automatically in the event of a significant system upset.

As a further guard against accidents, the project will develop operating procedures to implement a periodic inspection and leak detection program, a patrol program, and a gas leak detection survey. In addition, an operating procedure will be implemented for continuing pipeline surveillance, to includes periodic on site inspections by location supervision. This procedure will include a program for reviewing maintenance, patrol, corrosion and other tests, leak detection and

pipeline historical records to assess potential areas requiring pipe replacement or increased maintenance.



**TABLE 6.1**  
**SUMMARY OF IMPACTS AND MITIGATION MEASURES FOR THE BOLIVIA-BRAZIL GAS PIPELINE PROJECT (BOLIVIAN PORTION)**

ENVIRONMENTAL PARAMETER	IMPACT AND CAUSAL ACTIVITY	CLASSIFICATION	COMMENTS	KEY MITIGATION MEASURES
Climate	No impacts on climate parameters are expected	N/A	N/A	N/A
Air Quality	Release of dust and particulate due to construction activities and traffic	Adverse, Direct, Temporary, Localized, Proximal, Reversible, Mitigable, Less than Significant.	Effects are expected to be largely avoidable. Actual emissions will likely be minimal and localized.	If available, water should be used to wet construction areas (Section 7.5.5).
	Emission of contaminants from engines and other equipment operation	Adverse, Direct, Temporary, Localized, Proximal, Reversible, Mitigable, Less than Significant.	Effects are expected to be largely avoidable. Actual emissions will likely be minimal and localized.	Proper engine and equipment maintenance and minimization of operation times (Section 7.5.5).
	Emissions associated with turbines at compressor stations	Adverse, Direct, Permanent, Localized, Proximal, Reversible, Mitigable, Significant	Screen-modeling suggests that some Bolivian standards could be exceeded.	Final design will incorporate measures to ensure compliance with applicable regulations (Section 7.5.5).
Geology	Need for blasting due to rock outcroppings	Adverse, Direct, Permanent, Localized, Proximal, Irreversible, Mitigable, Less than Significant.	Outcrops are unlikely throughout the route. Higher probability of occurrence in the Puerto Suárez area.	If blasting is necessary, best management techniques for blasting will be employed (Appendix B).
	Likelihood of earthquakes affecting the pipeline	(earthquakes would affect pipeline safety and operation)	Earthquake records suggest that earthquakes are unlikely.	Design considerations will provide for standard pipeline protection (Appendix B).

**TABLE 6.1**  
**SUMMARY OF IMPACTS AND MITIGATION MEASURES FOR THE BOLIVIA-BRAZIL GAS PIPELINE PROJECT (BOLIVIAN PORTION)**

ENVIRONMENTAL PARAMETER	IMPACT AND CAUSAL ACTIVITY	CLASSIFICATION	COMMENTS	KEY MITIGATION MEASURES
Geomorphology (land forms)	Changes in local topography due to cut and fill, grading, and road improvement activities.	Neutral, Direct, Temporary, Localized, Proximal, Reversible, Mitigable, Less than Significant	Changes on the land forms will be negligible.	Restore original grade (Section 7.5.1).
Soils	Increased erosion potential due to vegetation clearing, trenching, spoil piling, road improvements, and other construction activities.	Adverse, Indirect, Temporary, Localized, Proximal, Reversible, Mitigable, Less than Significant	Much of the area of influence is rather flat, with low precipitation, and natural vegetation cover, which reduce the potential for erosion. Observations on the 3-yr old cut line suggests low erosion potential.	Application of erosion prevention and control techniques (Section 7.5.1).
	Soils compaction due to heavy traffic on the ROW.	Adverse, Direct, Temporary, Localized, Proximal, Reversible, Mitigable, Significant.	Much of the ROW traverses areas of Quaternary deposits, likely prone to compaction.	Soils restoration techniques during final grade (Section 7.5.1).
	Potential scouring and bank erosion due to stream crossing activities.	Adverse, Indirect, Temporary, Localized, Proximal, Reversible, Mitigable, Less than Significant.	Water courses along the route tend to have shallow cross-section, with gently sloping banks and low scouring.	Application of wetland and stream crossing techniques (Section 7.5.2).
	Other potential effects: Soil layers mixing, nutrient leaching, loss of organic layer.	Adverse, Direct, Temporary, Localized, Proximal, Reversible, Mitigable, Less than Significant	Immediate effects are more likely to be significant in wetland areas where an organic layer exists. In most of the route, soils are sandy, with poor horizon development and little or no organic layer.	Application of appropriate construction final grading techniques (Sections 7.5.1, 7.5.2).

**TABLE 6.1**  
**SUMMARY OF IMPACTS AND MITIGATION MEASURES FOR THE BOLIVIA-BRAZIL GAS PIPELINE PROJECT (BOLIVIAN PORTION)**

ENVIRONMENTAL PARAMETER	IMPACT AND CAUSAL ACTIVITY	CLASSIFICATION	COMMENTS	KEY MITIGATION MEASURES
Soils (cont...)	Potential sudden erosion due to discharge of hydrotest water.	Adverse, Direct, Temporary, Localized, Proximal, Reversible, Mitigable, Less than Significant.	Hydrotest water will be discharged in upland areas.	Application of measures to minimized the potential for erosion, such as energy dissipation devices (Section 7.5.3).
Groundwater	Potential mixing of aquifers.	Adverse, Indirect, Permanent, Localized, Remote, Reversible, Not Mitigable, Less than Significant	Groundwater resources seem to be adequate for the project with relatively high annual recharge. Effects are likely to be less than significant with the application of appropriate management techniques.	Groundwater resources will be evaluated before well establishment to determine if they meet project needs. Wells will be cased to avoid aquifer interaction (Section 7.5.4).
	Potential groundwater contamination in the case of accidental spills.	Adverse, Direct, Temporary, Localized, Remote, Reversible, Not Mitigable, Less than Significant		
	Potential lowering of the water table due to withdrawal of water for camps.	Adverse, Direct, Temporary, Localized, Remote, Reversible, Not Mitigable, Less than Significant		
Surface Water	Potential increase in sediment loads due to construction activities.	Adverse, Direct, Temporary, Localized, Proximal, Reversible, Mitigable, Less than Significant.	The main rivers to be crossed are shallow and carry important sediment loads. The additional load is likely to be insignificant.	Application of erosion and sedimentation control measures (Section 7.5.1).

**TABLE 6.1**  
**SUMMARY OF IMPACTS AND MITIGATION MEASURES FOR THE BOLIVIA-BRAZIL GAS PIPELINE PROJECT (BOLIVIAN PORTION)**

ENVIRONMENTAL PARAMETER	IMPACT AND CAUSAL ACTIVITY	CLASSIFICATION	COMMENTS	KEY MITIGATION MEASURES
Surface Water (cont.)	Temporary disruption to local hydrology (drainage patterns) due to wetland and water body crossing activities.	Adverse, Direct, Temporary, Localized, Proximal, Reversible, Mitigable, Less than Significant.	Most water crossings will be on shallow, slow flowing waters, thus reducing the magnitude of potential effects on local drainage patterns. Similarly, low rainfall reduces the risk of drainage problems.	Application of special wetland and water body construction techniques (Section 7.5.2).
	Permanent modification of local drainage patterns due to placement of fill and impervious surface for project facilities (e.g., compressor stations).	Adverse, Direct, Permanent, Localized, Proximal, Reversible, Mitigable, Less than Significant.	This potential impact is considered less than significant because of low rainfall, generally flat terrain, and limited placement of fill and impervious surfaces.	Proper design of stormwater management systems and cross drains where necessary (Appendix B).
	Potential reduction in surface water availability at the source due to withdrawal for hydrostatic testing.	Adverse, Direct, Permanent, Localized, Proximal, Reversible, Mitigable, Less than Significant.	The main sources of hydrotest water will be the Río Grande, Río San Miguel and Río Otuquis. Withdrawal will be limited to protect aquatic life, and preserve water volumes for other uses downstream.	This impact can be avoided with proper calculation of surface flow and withdrawal rate and volume (Section 7.5.3).
	Potential contamination of surface waters due to accidental spills.	Adverse, Direct, Temporary, Localized, Proximal, Reversible, Mitigable, Less than Significant.	Project activities will require the utilization of hazardous materials such as gasoline, oil, and paints, but in small quantities and in localized areas.	This impact can be largely avoided by applying proper techniques to manage and dispose hazardous materials (Section 7.5.6).

**TABLE 6.1**  
**SUMMARY OF IMPACTS AND MITIGATION MEASURES FOR THE BOLIVIA-BRAZIL GAS PIPELINE PROJECT (BOLIVIAN PORTION)**

ENVIRONMENTAL PARAMETER	IMPACT AND CAUSAL ACTIVITY	CLASSIFICATION	COMMENTS	KEY MITIGATION MEASURES
Surface Water (cont...)	Potential contamination of surface waters due to untreated discharges of domestic wastewater.	Adverse, Direct, Temporary, Localized, Proximal, Reversible, Mitigable, Less than Significant.	Domestic wastewater will be generated mainly at the workers camps.	Proper treatment and discharge of domestic wastewater (Section 7.5.6).
	Potential contamination of surface water (and groundwater) due to improper solid wastes disposal.	Adverse, Direct, Temporary, Localized, Proximal, Reversible, Mitigable, Less than Significant.	Solid and domestic wastes will be produced in all construction and camp areas.	Waste management must include minimization, separation, recycling, and proper disposal procedures (Section 7.5.6).
Vegetation	Removal of vegetation biomass due to clearing activities.	Adverse, Direct, Temporary, Localized, Proximal, Reversible, Mitigable, Significant.	A 5-m cut line along the majority of the route was established in 1993. The project will result in additional impacts on this existing disturbance.	This impact is unavoidable. Localized revegetation and compensation will be provided (Sections 7.5.1 and 7.6.1).
	Removal of individuals of species of special concern.	Adverse, Direct, Temporary, Localized, Proximal, Mitigable, Less than Significant.	In the Dry Chaco area, a number of endemic species as well as species used for different purposes will be affected.	This impact is unavoidable but it will be minimized by containing the clearing within the right of way (Section 7.6.1).
	Loss of tall forest canopy in the Bañados de Izozog (Río Parapetí) and low forest canopy in the Dry Chaco.	Adverse, Direct, Permanent, Localized, Proximal, Mitigable, Less than Significant.	In the Bañados, the presence of vines may result in falling trees dragging adjacent trees located outside the ROW. This is not the case in the vine-free uplands.	This impact is unavoidable but it will be minimized by containing the clearing within the right of way (Section 7.6.1).

**TABLE 6.1**  
**SUMMARY OF IMPACTS AND MITIGATION MEASURES FOR THE BOLIVIA-BRAZIL GAS PIPELINE PROJECT (BOLIVIAN PORTION)**

ENVIRONMENTAL PARAMETER	IMPACT AND CAUSAL ACTIVITY	CLASSIFICATION	COMMENTS	KEY MITIGATION MEASURES
Fauna	Direct incidental loss of individuals (including species of special concern) due to construction activities.	Adverse, Direct, Temporary, Localized, Proximal, Mitigable, Less than Significant.	Slow moving and/or small terrestrial animals, such as tortoises, are most likely to be affected. Snakes are likely to be particularly affected given human aversion toward them.	This impact can be minimized by applying common sense and training the work force about protecting the natural resources (Sections 7.6.1 and 7.8.1).
	Increase in the hunting pressure on large mammals and reptiles (including species of special concern)	Adverse, Direct, Temporary, Localized, Proximal, Mitigable, Significant.	Perhaps the most important potential impact due to the remoteness of the area, the abundance of wildlife, and the special concern status of many species.	Strict measures will be applied to avoid undue impacts on wildlife (Sections 7.6.1 and 7.7.1).
	Potential entrapment of fish at intake for hydrotest water.	Adverse, Direct, Temporary, Localized, Proximal, Mitigable, Less than Significant.	This impact is largely avoidable.	Provisions will be made to prevent fish and other animals from entering the intake (Section 7.5.3).
	Permanent loss of habitat along the cleared ROW.	Adverse, Direct, Permanent, Localized, Proximal, Mitigable, Less than Significant.	This will affect mostly insects and other small animals. Most animal will move away from the ROW. At the regional level, the loss of habitat is negligible.	This impact is unavoidable but it will be minimized by containing the clearing within the right of way (Section 7.7.1).
	Habitat fragmentation due to the establishment of the ROW.	Adverse, Direct, Permanent, Localized, Proximal, Mitigable, Less than Significant.	A cut line has already been established throughout the majority of the route. The additional impact is considered negligible.	This impact is unavoidable but it will be minimized by containing the clearing within the right of way (Section 7.7.1).

**TABLE 6.1**  
**SUMMARY OF IMPACTS AND MITIGATION MEASURES FOR THE BOLIVIA-BRAZIL GAS PIPELINE PROJECT (BOLIVIAN PORTION)**

ENVIRONMENTAL PARAMETER	IMPACT AND CAUSAL ACTIVITY	CLASSIFICATION	COMMENTS	KEY MITIGATION MEASURES
Species of Special Concern	Direct loss through incidental mortality, increased hunting, or secondary habitat effects.	Adverse, Direct, Temporary, Localized, Proximal, Mitigable, Less than Significant.	Species of special concern are rather abundant in the project area.	This impact is unavoidable but it will be minimized by containing the clearing within the right of way and strictly enforcing species protection measures (Sections 7.6.1 and 7.7.1).
Protected Areas	Encroachment into the Gran Chaco National Park and the Historic National Park Santa Cruz la Vieja.	Adverse, Direct, Permanent, Localized, Proximal, Mitigable, Less than Significant.	The project does not represent conflict with approved land uses in the parks.	This impact is unavoidable, but it will be minimized and compensated (Sections 7.7.1 and 7.8.4).
Population	Slight and temporary increase in the population of the study area due to the influx of 1000-1500 workers.	Beneficial, Direct, Temporary, Extended, Proximal, Significant	It is unlikely that pipeline workers will settle permanently in the study area.	Measures will be taken to accommodate the incoming workers (Section 7.7.2).
	Potential for cultural and social tension due to the interaction between residents and incoming workers.	Adverse, Direct, Temporary, Localized, Proximal, Mitigable, Less than Significant.	Cultural and social differences may arise.	Measures will be applied to promote positive interactions and a productive cultural exchange between residents and incoming workers (Section 7.7.2).

**TABLE 6.1**  
**SUMMARY OF IMPACTS AND MITIGATION MEASURES FOR THE BOLIVIA-BRAZIL GAS PIPELINE PROJECT (BOLIVIAN PORTION)**

ENVIRONMENTAL PARAMETER	IMPACT AND CAUSAL ACTIVITY	CLASSIFICATION	COMMENTS	KEY MITIGATION MEASURES
Population (cont...)	Potential for a slight increase in the incidence of contagious diseases, including sexually transmitted diseases due to the interaction between residents and incoming workers.	Adverse, Direct, Temporary, Localized, Proximal, Mitigable, Less than Significant.	Camp workers will visit nearby communities occasional in search of relaxation and entertainment.	Measures will be applied to promote hygiene and safe practices (Section 7.7.4).
Economy	Potential for a temporary increase in the demand for services and goods to accommodate the influx of workers into the study area.	Beneficial, Direct, Temporary, Extended, Proximal, Significant	Camp worker are expected to spend a portion of their pay locally.	None necessary.
	Temporary employment of 500-1000 unspecialized local labor for construction-related work.	Beneficial, Direct, Temporary, Extended, Proximal, Significant.	There are significant opportunities for local recruitment for the pipeline labor force.	Fair hiring and remuneration practices will be applied.
	Potential increase in transportation-dependent activities due to improvements on the road system.	Beneficial, Direct, Permanent, Temporary, Extended, Proximal, Significant.	There are significant opportunities for tourism promotion.	None necessary. Local areas with tourism potential (e.g., hot springs at the Río Aguas Calientes headwaters) will be protected during project construction.
Land Use	Potential for changes in land use patterns.	Neutral, Direct, Permanent, Localized, Less than Significant.	The pipeline project does not represent conflicts with existing or planned land uses.	This impact is considered negligible.



**TABLE 6.1**  
**SUMMARY OF IMPACTS AND MITIGATION MEASURES FOR THE BOLIVIA-BRAZIL GAS PIPELINE PROJECT (BOLIVIAN PORTION)**

ENVIRONMENTAL PARAMETER	IMPACT AND CAUSAL ACTIVITY	CLASSIFICATION	COMMENTS	KEY MITIGATION MEASURES
Indigenous Populations	Encroachment into the historical range of Ayoreode and Izoceños groups.	Neutral, Direct, Permanent, Localized, Less than Significant.	Their territory has been afforded protection through the establishment of the Gran Chaco National Park.	Compensatory measures will be applied to assist in the consolidation of the management plan for the park (Section 7.8.4).
Cultural, Archaeological, and Historical Resources	Potential disturbance to sites of special concern.	Adverse, Direct, Permanent, Localized, Proximal, Mitigable, Less than Significant.	No sites of special concern were identified along the pipeline alignment. Historical resources occur particularly in and around San José de Chiquitos.	A contingency plan will be applied for incidental finding of sites of special concern (Section 7.7.3).

TABLE 6.2 AREA OF VEGETATION, SOILS, AND FORESTRY POTENTIAL TYPES AFFECTED BY THE CONSTRUCTION OF THE RIGHT-OF-WAY <sup>1</sup>			
ENVIRONMENTAL PARAMETER	COVER TYPE	PIPELINE LENGTH WITHIN COVER TYPE (KM)	TOTAL AREA AFFECTED (HA)
Vegetation	Very Low Forest (scrub)	65.8	197.5
	Low Forest	202.0	606.3
	Medium Forest	158.1	474.2
	Very Tall forest	1.1	3.2
	Riparian Forest	41.2	123.5
	Pastures	7.4	22.3
	Savannah	73.9	221.8
	Marshes and Swamps, including Palm Formations	2.0	6.1
Physiography and Soils	Steep Slopes	15.9	47.8
	Foothills	18.5	55.5
	Ancient Alluvial Plain	167.5	502.4
	Floodplain	21.4	64.3
	Recent Alluvial Plain	22.9	68.8
	Aeolian Plain	4.6	13.8
	Isolated Hills of the Chaco	106.2	318.7
	Consolidated Sediments	47.1	141.2
	Alluvio-Aeolian Deposits	33.0	99.0
	Dissected Plateaus	114.3	342.9
Forestry Potential	No Forestry Potential	157.2	471.8
	Low Forestry Potential	159.1	477.4
	Limited Forestry Potential	94.5	283.3
	Moderate Forestry Potential	140.7	422.1

<sup>1</sup> Assuming a right-of-way width of 30 meters

**CHAPTER 7.0**  
**ENVIRONMENTAL MANAGEMENT**

**TABLE OF CONTENTS**

7.1	OBJECTIVES .....	7 - 1
7.2	ORGANIZATION OF THE ENVIRONMENTAL MANAGEMENT PLAN .....	7 - 1
7.3	GENERAL PRECONSTRUCTION MANAGEMENT STRATEGIES ..	7 - 2
7.4	COMPONENTS OF THE ENVIRONMENTAL MANAGEMENT STRATEGY .....	7 - 2
7.5	PHYSICAL ENVIRONMENT .....	7 - 4
	7.5.1 Erosion Control, Revegetation, and Maintenance Procedures ...	7 - 5
	7.5.2 Wetland and Waterbody Construction and Mitigation Procedures (Stream and River Crossings) .....	7 - 7
	7.5.3 Hydrostatic Testing Procedures .....	7 - 8
	7.5.4 Protection of Groundwater Resources .....	7 - 10
	7.5.5 Air Quality and Noise Control .....	7 - 11
	7.5.6 Waste Management Procedures .....	7 - 11
	7.5.7 Spill Prevention, Control, and Containment Procedures .....	7 - 13
7.6	BIOLOGICAL ENVIRONMENT .....	7 - 15
	7.6.1 Vegetation and Wildlife Protection .....	7 - 16
7.7	SOCIOECONOMIC ENVIRONMENT .....	7 - 17
	7.7.1 Right-of-Way Protection .....	7 - 17
	7.7.2 Community Relations .....	7 - 18
	7.7.3 Protection of Cultural, Historical, and Archaeological Resources .	7 - 18
	7.7.4 Construction Safety Plan .....	7 - 19
7.8	GENERAL MITIGATION MEASURES .....	7 - 21
	7.8.1 Workers Environmental Training .....	7 - 21
	7.8.2 Environmental Inspection Program .....	7 - 22
	7.8.3 Environmental Monitoring Program .....	7 - 24
	7.8.4 Compensatory Mitigation Program .....	7 - 25

**CHAPTER 7.0**  
**ENVIRONMENTAL MANAGEMENT**

**TABLE OF CONTENTS**

7.8.5	Contingency Plan . . . . .	7 - 26
7.8.6	Abandonment Procedures . . . . .	7 - 27
7.9	COST OF MITIGATION MEASURES . . . . .	7 - 28

**CHAPTER 7.0**  
**ENVIRONMENTAL MANAGEMENT**

**LIST OF TABLES**

<u>TABLE NO.</u>	<u>DESCRIPTION</u>
7.1	SUMMARY OF ESTIMATED COSTS ASSOCIATED WITH THE IMPLEMENTATION OF THE ENVIRONMENTAL MANAGEMENT PROGRAM

## **7.0 ENVIRONMENTAL MANAGEMENT**

### **7.1 OBJECTIVES**

The Environmental Management Plan (EMP) is presented in Appendix B. It establishes guidelines and procedures for measures and plans that address all the environmental aspects of the project, including impact mitigation measures, environmental construction procedures, health and safety, community relations, impact compensation, environmental monitoring, and environmental maintenance.

The main objectives of the EMP are: 1) to avoid, minimize, control, or mitigate potential impacts from the project construction and operation on the physical, biological, and socioeconomic environment, and 2) to ensure continued project compliance with applicable environmental regulations.

The pipeline route and the location of associated facilities were selected in an effort to minimize physical, biological, cultural and socio-economic impacts while making the project economically feasible. However, some unavoidable impacts will occur as a result of construction and operation of the pipeline. Most of the impacts to soils, water quality, and to some extent vegetation and wildlife, will be localized and temporary. These impacts can be controlled or limited to acceptable levels by the application of mitigating measures during and after construction.

This chapter provides a summary of the elements of the EMP.

### **7.2 ORGANIZATION OF THE ENVIRONMENTAL MANAGEMENT PLAN**

Due to its complexity and scope, the implementation of the EMP requires the establishment of a specific organization and specific funding support. An Environmental Manager will coordinate the activities of a technical staff responsible for inspecting, monitoring, and controlling EMP compliance.

The Environmental Manager will also be responsible for technical, community, and administrative affairs relating to the EMP. The Environmental Manager will be responsible for overall compliance with the EMP and will be assisted by an appropriate staff to address all technical questions and project-specific issues relating to the EMP, including liaison between the general public and environmental issues related to the project. This person will interact with local communities to keep them informed of the project's events and to properly address any issues of concern.

### **7.3 GENERAL PRECONSTRUCTION MANAGEMENT STRATEGIES**

Some general mitigation measures are applicable during the final design and preconstruction activities, including the following:

- *Establish an Adequate Construction Schedule.*
- *Design Construction Areas in Order to Minimize Impacts.*
- *Construction of Fences and Gates.*
- *Establish Access Restrictions.*
- *Conduct a Pre-Construction Survey of Right-of-Way Conditions.*

### **7.4 COMPONENTS OF THE ENVIRONMENTAL MANAGEMENT STRATEGY**

The overall environmental strategy for the project is described in the following documents:

- Environmental Management Plan, presented in Appendix B;
- Health and Safety Plan, presented in Appendix C; and
- Contingency Plan, presented in Appendix D.

The environmental management of the project considers 18 components categorized according to the following classification:

- Physical Environment
- Biological Environment
- Socioeconomic Environment
- General Category

The components in each of these categories are as follows:

### **Physical Environment**

- Erosion Control, Revegetation, and Maintenance Procedures
- Wetland and Water Body Construction and Mitigation Procedures
- Hydrostatic Testing Procedures
- Protection of Groundwater Resources
- Air Quality and Noise Control
- Waste Management Procedures
- Spill Prevention, Control, and Containment Procedures

### **Biological Environment**

- Vegetation and Wildlife Protection Guidelines
- The Erosion Control, Revegetation, and Maintenance Procedures and Wetland and Water Body Construction and Mitigation Procedures

### **Socioeconomic Environment**

- Right-of-Way Protection
- Community Relations
- Archaeological and Historical Resources Protection Guidelines
- Health and Safety Guidelines



## General Mitigation Measures

- Workers' Environmental Training
- Environmental Inspection
- Environmental Monitoring
- Compensatory Mitigation
- Contingency Plan
- Abandonment Procedures

In the following sections, environmental management measures are summarized in a standard format in which the information for each type of measure is presented as follows:

**Impact.-** The environmental impact(s) the mitigation measure is intended to address.

**Duration.-** The duration or period of time the mitigation measure will be implemented.

**Benefits.-** Identifies the environmental resource that benefits from the application of the measure.

**Character.-** Whether the mitigation measure is aimed at preventing, minimizing, or compensating for project impacts.

**Description.-** A brief description of the measure.

## 7.5 PHYSICAL ENVIRONMENT

The following mitigating measures will be implemented to avoid, minimize, or mitigate for potential impacts of project construction on the physical environment. In many cases, the implementation of these procedures will also address potential impacts to the biological environment.

### 7.5.1 Erosion Control, Revegetation, and Maintenance Procedures

**Impact:** Potential erosion, sedimentation, and turbidity.

**Duration:** Temporary (during construction activities and until right-of-way is stabilized).

**Benefits:** Soils, water quality, hydrology, aquatic flora and fauna.

**Character:** Prevention, minimization.

**Description:** The potential for erosion is the most common impact associated with construction activities; however, review of the field conditions throughout this pipeline route suggest that the erosion potential may be low. Erosion can be prevented or minimized utilizing a series of techniques which are now industry standard. In summary, the goals of the erosion control, revegetation, and maintenance measures are:

- To prevent soil erosion or sedimentation during construction activities.
- To provide sufficient bank stabilization, both temporary and permanent (as needed) to prevent deterioration of waterbody banks cut during construction activities.
- To provide adequate restoration of the right-of-way; and
- To provide for monitoring and maintenance of the area until stabilization and re-establishment of vegetation.

Key elements of the plan include the following:

- Install standard erosion control techniques, such as filter fabric fencing, slope breakers, trench breakers, and riprap prior to or during pipeline construction activities, preparation of work camps, access road improvements, or other associated activities.

- Inspect erosion control devices periodically to ensure that these barriers are not moved or disturbed. Repair damaged filter fabric fences or other erosion control barriers immediately.
- Stormwater sediment control structures are to be in place during initial ground disturbing activities.
- Replace trench spoil where possible.
- Construct permanent slope breakers as needed on slopes along the right-of-way.
- Selective revegetation. Slow recovery rates and low erosion potential make revegetation in the forested areas of the Chaco inadvisable. Natural resprouting through the rootstock of shrubs and trees as well as through germination from the seed bank will occur over time. Similarly, the recovery of native vegetation in marshes is anticipated to occur within a growing season.

Active revegetation is recommended in the aeolic plains associated with the Río San Miguel. This area includes a sandy substrate supporting grassy vegetation. If devoid of vegetation, wind erosion is likely to occur. The disturbed areas will be reseeded with a fast growing native grass or with vetiver grass (*Vetiveria zizanioides*), a fast-growing, thick-rooted grass used widely for erosion control in tropical and sub-tropical areas throughout the world (National Academy Press 1993). A nursery for Vetiver grass exists in Cochabamba, Bolivia.

## 7.5.2 Wetland and Waterbody Construction and Mitigation Procedures (Stream and River Crossings)

- Impact:** Disturbance of biological habitat, alteration of physical characteristics, sedimentation and turbidity.
- Duration:** Temporary (during construction activities).
- Benefits:** Vegetation, aquatic flora and fauna, water quality, hydrology.
- Character:** Prevention, minimization.

**Description:** The wetland and waterbody construction and mitigation procedures specify construction procedures for stream and waterbody crossings (Appendix B). If any part of these procedures is not technically feasible at a particular stream or waterbody crossing, modifications will be made to address site-specific conditions.

All rivers, streams and wetlands will be crossed using the open cut construction method. Heavy equipment will traverse wetlands and/or streams using appropriate equipment bridges where needed.

The primary goals of the Wetland and Waterbody Construction and Mitigation Procedures are:

- Minimize disturbance to wetland and waterbody to the maximum extent practicable.
- Consider site-specific constraints to develop alternative crossing techniques.
- Minimize duration of disturbance.
- Provide for adequate physical restoration of site.
- Avoid long-term impact to aquatic organisms by protecting water quality.

In general, the following guidelines apply to most stream or waterbody crossings:

- Minimize the size of crossing areas and reduce clearing of trees and other vegetation on stream bank as much as possible.
- Construct crossings as close as possible to perpendicular to the waterbody channel.
- Minimize disruption of wetland and waterbody substrate during crossings. Heavy equipment should utilize equipment bridges or other means to avoid rutting or to minimize disturbance.
- Maintain adequate water flow rates and hydrologic patterns.
- Minimize turbidity and sedimentation.
- Complete construction, trenching and backfilling at all crossings as quickly as possible.
- Fueling or maintaining equipment and storing fuels and other chemicals must occur at least 15 meters from water bodies and abide by the Spill Prevention, Control, and Containment (SPCC) Procedures (Appendix B).
- Install appropriate erosion control devices along water bodies and crossing points.
- Remove construction debris, materials, and equipment bridges as soon as practical after construction is complete.
- Restore waterbody banks and provide temporary or permanent stabilization where needed.
- Maintain or restore site physical characteristics (e.g. recontouring to restore topography).

### 7.5.3 Hydrostatic Testing Procedures

**Impact:** Disturbance of biological habitat, alteration of physical characteristics, erosion, sedimentation, and turbidity.

**Duration:** Temporary (during hydrostatic testing).

**Benefits:** Vegetation, fauna, soils, water quality, hydrology.

**Character:** Prevention, minimization.

**Description:** Hydrostatic testing of the pipeline will be conducted after pipeline installation is completed (Appendix B). If possible, all test water for testing will be withdrawn from the Río Grande, Rio San Miguel and Rio Otuquis and discharged to uplands where possible.

Goals of the hydrostatic testing procedures include:

- Avoid disruption of hydrology during withdrawal of water.
- Minimize impacts to aquatic fauna.
- Minimize erosion, sedimentation, disruption of soils and physical characteristics of discharge area.
- Protect water quality of receiving waters and adjacent wetlands

*Withdrawal.* Withdrawal of water for hydrostatic testing will occur via an intake hose which will be screened to prevent fish entrainment. Additionally, the flow of intake waters will be maintained to protect aquatic life, provide for all waterbody uses, and provide for downstream withdrawals by existing users.

Guidelines for withdrawal of hydrostatic test water:

- The intake hose will be screened to prevent fish from being drawn into the hose.
- Pumping must not interfere with stream flow rates required to protect aquatic life and to provide for all waterbody uses.
- Hydrostatic test manifolds will be located outside wetlands and riparian areas to the greatest extent possible.

*Discharge Methods and Rates.* Once the hydrostatic test is complete, water will be discharged from the pipeline.

The following guidelines apply to the discharge of hydrostatic test water:

- When discharging test water, regulate the discharge rate and use energy dissipation devices so that erosion of upland areas, stream bottom scour, suspension of sediments, or excessive stream flow are prevented.
- Discharge test water through a dissipation device into a filter bag, filter fabric fence or other containment structure.
- Discharge in uplands to the extent possible or at other locations to minimize return of test water to water bodies.
- Avoid discharge of test water into any water bodies which provide habitat for species of special concern.

#### 7.5.4 Protection of Groundwater Resources

**Impact:** Potential contamination, lowering, or mixing of groundwater resources.

**Duration:** Temporary and Permanent.

**Benefits:** Groundwater, human population which use the resource.

**Character:** Prevention.

**Description:** Prevention of Potential Contamination. Groundwater resources will be protected from potential contamination through the implementation of the SPCC Procedures (Section 7.5.7).

Protection of the Aquifers. The project will require the installation of several water wells to depths between 100 and 200 m. Aquifer mixing will be prevented by properly casing the well.

Withdrawal rates and periods will be regulated to prevent lowering of the aquifer volumes.

### 7.5.5 Air Quality and Noise Control

**Impact:** Potential impacts to air quality and impacts to humans and wildlife due to exposure to noise.

**Duration:** Temporary and Permanent.

**Benefits:** Humans and wildlife.

**Character:** Prevention, minimization.

**Description:** Air Quality. The following measures will be applied to prevent or minimize impact to air quality.

1. All engines will be properly maintained to minimize emissions of contaminants.
2. A schedule for the operation of engines will be established to minimize, to the extent practicable, the time of operation of emission sources.
3. Detail design will consider modifications to stack height and other parameters related to the operation of the compressor stations to ensure compliance with applicable regulations.

Noise. Noise impacts are expected to be less than significant. Workers who are exposed to noise generators, such as compressors or heavy machinery will be provided with appropriate protection, such as ear plugs or mugs.

### 7.5.6 Waste Management Procedures

**Impact:** Disruption of biological habitat, alteration of physical characteristics, water quality impacts to surface or groundwater, health and safety.

**Duration:** Temporary and Permanent.



**Benefits:** Vegetation, fauna, water quality, hydrology.  
**Character:** Prevention, minimization.

**Description:** Solid Waste. Solid waste management will be implemented based on the following principles:

1. Minimize waste generation.
2. Maximize recycling and reusing.
3. Dispose waste appropriately.

Appropriate disposal facilities will be provided during the construction phase. Solid waste will be collected in clearly identified receptacles located at strategic points along the pipeline route and within work camps, staging areas, and other associated facilities. Plastics, metals, or any other non-biodegradable materials brought to the work site will be discarded into appropriate containers and/or containment facilities and/or disposed of at appropriate facilities, which may include sanitary landfills at workers camps. Recycling of materials will occur whenever possible. Paper, wood and other dry refuse may be burned in a pre-constructed pit. No plastics or synthetic polymer materials will be burned.

Sanitary Waste. Extended aeration package plants or conventional septic systems will be constructed for disposal of sanitary wastes in areas of high worker concentration such as work camps. Where possible, discharge of treated effluent will be to upland areas away from water bodies. If discharge is to receiving waters, the potential for assimilation of treated effluent will be considered in selecting receiving streams. Waste water from work camps may be disposed by land application in appropriate areas.

Hazardous Waste. Hazardous waste generated during the construction of the pipeline will be collected, properly contained, and transported to temporary storage areas at work camps or at designated locations along the pipeline route. Temporary storage areas will be sited away from surface waters, wetlands, and agricultural areas. Such wastes will be transported to a central location for collection and disposal. One person (or one person at each collection/disposal facility) will be responsible for collecting, inventorying, and disposing of hazardous waste. The management and disposal of hazardous waste will be conducted and documented in accordance with Bolivian regulations and/or sound environmental management practices.

#### 7.5.7 Spill Prevention, Control, and Containment Procedures

**Impact:** Potential disruption of biological habitat, water quality impacts to surface or groundwater, health and safety.

**Duration:** Temporary and Permanent.

**Benefits:** Vegetation, fauna, water quality.

**Character:** Prevention, minimization, restoration.

**Description:** The SPCC Procedures (Appendix B) addresses actions used to prevent spills and actions to be taken should a spill occur. Emergency notification procedures are included and will be expanded to include appropriate additional individuals/agencies as they are identified.

The project sponsors are committed to complying with all regulations governing hazardous materials and spills of fuels, lubricants, and chemicals. The requirements of the SPCC Procedures will be explained to all workers handling, transporting, or responsible for distributing fuels, lubricants, or chemicals.

Summary of guidelines from the SPCC Procedures:

- Store all fuel and potentially hazardous materials at least 30 meters away from private wells and 100 meters from municipal or community water supply wells.
- Store fuel, lubricants, or hazardous materials at least 15 meters away from stream banks or wetland boundaries.
- No potentially hazardous or hazardous materials may be transported onto the right-of-way with the exception of equipment fuel (gasoline, diesel, etc.) or lubricants (engine oils, grease, etc.).
- Store all drums on pallets or drum racks.
- Provide secondary containment for all containers with aggregate capacity of 55-gallons or greater.

If a spill occurs, the following procedures must be followed:

- Immediately notify the Environmental Inspector.
- Evacuate the area, if warranted.
- Stop operation of affected equipment/area, if warranted.
- Turn off utilities to area, if necessary.
- Barricade the area to prevent entry of unauthorized personnel or equipment. Establish a single point of entry and exit to control access to spill area.
- Take whatever steps necessary to eliminate source of leak or spill (e.g., shut off valves, upright containers, or stop pumps).
- Collect information concerning the nature and size of the spill. A report will be completed by the Environmental Inspector, who will rely on information obtained from personnel working in the area of the spill.
- Environmental Inspector shall notify the Environmental Manager, who will handle notifications to authorities, if required.

#### Controlling spills on land:

- Plug all drains the spill may access.
- Construct terrace dam or ditch to stop the spill's flow.
- Scatter sand sorbent pads or other similar materials to absorb the spill.
- If free standing fluid is present, skim fluid, and place into approved containers.

#### Controlling spills on pavement:

- Plug any drains that the spill may access.
- Construct/provide barriers to stop the flow. Use dirt berms, sand bags, or commercial absorptive pads to stop the spill's flow.
- Scatter sand sorbent pads, or other absorptive materials to absorb any excess spill material.
- If free standing fluid is present, skim fluids and place in approved container.

#### Controlling spills on water:

- Create a back current to limit out-flow of material.
- Use absorbent floats if available.
- Create shoreline earth berms or terrace dams to limit spill access to the shoreline.
- Recover spilled material from water surface using skimmers, pumps, or absorbent materials, if available.

## 7.6 BIOLOGICAL ENVIRONMENT

The following environmental measures will be implemented to provide protection and minimization of impacts to vegetation, fauna, and species of special concern encountered during

construction of the pipeline. Additionally, the Erosion Control, Revegetation, and Maintenance Procedures and the Wetland and Waterbody Construction and Mitigation Procedures discussed above includes important mitigating measures to minimize impacts to the biological environment as well as physical aspects of the environment.

### 7.6.1 Vegetation and Wildlife Protection

**Impact:** Disturbance to native vegetation and wildlife; increased hunting pressure.

**Duration:** Temporary (during construction activities).

**Benefits:** Indigenous fauna, species of special concern.

**Character:** Prevention, minimization.

**Description:** While some direct effects on vegetation and wildlife as a result of right-of-way clearing and construction activities are unavoidable, the objectives of these measures are to minimize those impacts and to prevent secondary impacts such as increased hunting pressure. Primary goals of the vegetation and wildlife protection plan include:

- Protection of rare, threatened, or endangered species.
- Minimization of disturbance during construction.
- Avoidance of hunting pressure on protected species or important indigenous species.
- Restoration of disturbed areas to extent possible to prevent long-term impacts.

While no specific regulations are in place to prevent harm to species of special concern, efforts will be made to minimize disturbance to flora and fauna encountered along the pipeline corridor and in the vicinity of work camps, storage yards, and other facilities associated with the project. Such efforts include avoiding disturbance to areas outside approved construction zones, limiting access to construction areas or associated facilities/activities, informing workers of status and protection of wildlife

and penalties for infractions, providing workers with materials depicting protected species which must not be harmed or harassed, and instructing workers on appropriate protocols in the event of accidental injury or mortality to wildlife.

## 7.7 SOCIOECONOMIC ENVIRONMENT

Potential impacts to the Socioeconomic Environment associated with pipeline construction include a variety of issues from effects on the local economy and indigenous people to protection of cultural, historical, and archeological resources. The following mitigating measures have been developed to minimize or mitigate for potential impacts occurring the socioeconomic environment.

### 7.7.1 Right-of-Way Protection

**Impact:** Potential secondary impacts due to right-of-way utilization as a transportation corridor.

**Duration:** Temporary and Permanent.

**Benefits:** All biological, physical, and cultural resources

**Character:** Prevention.

**Description:** The pipeline right-of-way is not intended to become a road. While colonization and traffic may be promoted by the existence of the right-of-way, it is anticipated that this effect will be low. Since 1993, when a cut line was established along the proposed alignment, no detectable colonization has occurred. Much of the study area has limitations for agricultural or forestry activities and may not be appealing to prospective colonists.

However, the right-of-way will be secured with barriers and gates to discourage its utilization by unauthorized people. Signs and public education will support the physical measures.

### 7.7.2 Community Relations

- Impact:** All socio-economic impacts.  
**Duration:** Temporary and Permanent.  
**Benefits:** Neighboring communities.  
**Character:** Prevention, minimization, restoration.

**Description:** As part of the management of the project, the sponsors will maintain a Community Relations program aimed at promoting good relations with the communities in the area of influence of the project, as well as providing environmental education and increasing awareness about the project and the environment.

The community relations program will include the following components:

1. Maintaining a Public Liaison during construction.
2. Developing an environmental education program.
3. Developing a public information program about the project.
4. Educating the construction labor force regarding proper relations with the host communities.

### 7.7.3 Protection of Cultural, Historical, and Archaeological Resources

- Impact:** Disturbance of cultural, historical and archeological sites and artifacts.  
**Duration:** Temporary (during construction activities).  
**Benefits:** Historical and cultural resources.  
**Character:** Prevention, minimization.

**Description:** Cultural resources may include prehistoric or historic sites, buildings, or objects such as projectile points, lithic tools, cooking debris, ceramic fragments or other evidence of previous human occupation. Human remains are also included in this category.

The project sponsor is committed to exercise extreme care with regard to cultural resources. The protocol addressed in the Accidental Discovery Plan for Archeological, Cultural and Human Remains, included in Appendix B will be implemented. In the event of a find, crews will halt work that would disturb the artifacts and notify the Environmental Inspector. Work will cease at that location, and the Ministry of Education and Culture will be notified. Any artifacts encountered will be secured and preserved until evaluated, then delivered to the Archaeological National Institute if so advised by the Ministry.

#### 7.7.4 Construction Safety Plan

**Impact:** Health and safety.  
**Duration:** Temporary (during construction) and Permanent (during operation).  
**Benefits:** Human and cultural resources.  
**Character:** Prevention, correction.

**Description:** A Construction Safety Plan (Appendix C) will provide explicit instructions regarding health and safety issues. This manual will apply to all contractor and subcontractor personnel as well as project personnel. The following subjects are covered in the Construction Safety Plan:

- Accident Prevention Responsibilities.
- Safety Training and Education.
- Personal Protective Equipment.
- First Aid.
- Good Housekeeping.



- Drinking Water.
- Sanitation.
- Occupational Noise Exposure.
- Radiation.
- Illumination
- Gas, Vapors, Fumes, Dusts and Mists.
- Ventilation.
- Respirator Protection.
- Fire Protection and Prevention.
- Flammable and Combustible Liquids.
- Signs, Signals and Barricades.
- Rigging Equipment for Material Handling.
- Tools - Hand and Power Operated Handling.
- Welding.
- Cranes.
- Automotive Equipment.
- Material Handling Equipment.
- Blasting.
- Working Over or Near Water.
- Construction Guidelines.
- Fire Protection Precautions.

Other information, such as the safety policy and management for this project, plus accident record forms are included in the plan. The Construction Safety Plan is included as Appendix C. All personnel will be provided a copy of this plan in conjunction with training. Newly hired personnel will be trained and provided a copy of the plan prior to commencement of work.

Additionally, a Safety Officer will be responsible for employee training and general oversight of safety issues. The Safety Officer will monitor personnel on the project to ensure compliance with the safety policy. If an infraction is discovered, the person committing the infraction will be re-trained and subsequently monitored to ensure compliance.

Based on job exposure, personal protective equipment (safety shoes, hard hats, eye protection, hearing protection, safety belts, respirators, and welder's helmets) may be required. Each crew leader will be responsible for safety supervision and reporting of accidents. The Safety Officer must be notified immediately of any accidents.

## 7.8 GENERAL MITIGATION MEASURES

In addition to the mitigating measures developed to address specific impacts to the physical, biological, or socioeconomic environment, several key measures will be implemented which will also reduce potential environmental impacts and assure overall compliance with the EMP. These measures are described below.

### 7.8.1 Workers Environmental Training

**Impact:** All biological, physical, and cultural impacts.

**Duration:** Temporary (during construction activities).

**Benefits:** All biological, physical, and cultural resources.

**Character:** Prevention, minimization, restoration.

**Description:** Environmental training will be provided for all employees prior to commencement of work. New workers brought to the project after the initiation of project activities will receive training as soon as is practicable following their arrival. Training will include the following topics:

- Right-of-way.
- Species of special concern.
- Streams and water bodies.
- Wetlands.
- Erosion control.
- Spill prevention, control, and containment.
- Water withdrawal and discharge.
- Cultural resources.

- Community relations.
- Contingency plan.

A formal training curriculum will be developed consisting of "classroom" type instruction (generally at the work camp sites). Materials developed will include a notebook style manual providing written and pictorial presentation of information covering the topics above and a video produced in appropriate language(s) providing verbal instruction on the topics.

### 7.8.2 Environmental Inspection Program

- Impact:** All biological, physical, and cultural impacts.  
**Duration:** Temporary (during construction activities).  
**Benefits:** All biological, physical, and cultural resources.  
**Character:** Prevention, minimization, restoration.

**Description:** An Environmental Inspector (having knowledge of the environmental conditions in the project area) will be appointed for each construction spread and will be responsible for monitoring construction areas and activities for environmental compliance. The Chief Environmental Inspector will recommend to stop work if an environmental violation occurs. Environmental Inspectors will provide assistance and guidance to all other members of the construction team regarding environmental issues. They will also coordinate required testing, monitoring, and training of personnel involved with the project as to environmental aspects.

At a minimum, the Environmental Inspector(s) shall be responsible for:

1. Ensuring compliance with the requirements of the plans and procedures and all license and permit conditions imposed on the project by Bolivian regulatory agencies.

2. Verifying that the limits of authorized construction work areas and locations of access roads are properly marked before clearing.
3. Verifying the location of drainage and irrigation systems.
4. Identifying stabilization needs in all areas.
5. Locating dewatering structures and slope breakers to ensure they will not direct water into known cultural resource sites or locations of sensitive species.
7. Verifying that trench dewatering activities do not result in the deposition of sand, silt, and/or sediment near the point of discharge into a wetland or waterbody. If such deposition is occurring, the dewatering activity shall be stopped and the design of the discharge shall be changed to prevent reoccurrence.
8. Testing subsoil and topsoil in agricultural and residential areas to measure compaction and determine the need for corrective action.
9. Advising the Chief Environmental Inspector when conditions (such as wet weather) make it advisable to restrict construction activities.
10. Ensuring restoration of contours and topsoil.
11. Approving imported soils for use in agricultural and residential areas.
12. Ensuring that temporary erosion controls are properly installed and maintained daily, if necessary.
13. Inspecting temporary erosion control measures on a daily basis in areas of active construction or equipment operation, on a regular basis in areas with no construction or equipment operation, and as soon as possible after each one inch of rainfall.
14. Ensuring the repair of all ineffective temporary erosion control measures within 24 hours of identification.
15. Keeping records of compliance with the environmental conditions of the appropriate permits, certificates, and authorizations, and the mitigation measures proposed by the project sponsor in the applications submitted during active construction and restoration; and,

16. Establishing a program to monitor the success of restoration. Implementation of this program may be transferred to the operating entity upon completion of construction and restoration activities.

The project inspection program is discussed in detail in the Environmental Construction Plan included as Appendix B.

### 7.8.3 Environmental Monitoring Program

- Impact:** All biological, physical and cultural impacts.  
**Duration:** Temporary (until the area is stabilized).  
**Benefits:** All biological, physical and cultural resources.  
**Character:** Prevention, minimization, restoration.

**Description:** During construction, monitoring will be part of the inspection program. Environmental monitoring may include, but not be limited to, erosion control, water quality, indigenous and protected wildlife species, cultural resources, water resources, vegetation, and protected areas.

As stated earlier under the section pertaining to the Environmental Inspector's duties and responsibilities, the Environmental Inspector will prepare a plan to monitor the success of revegetation and stabilization of the right-of-way and temporary work areas following construction.

Monitoring will also include visual inspection and documentation of establishment of temporary vegetation for sediment and substrate stabilization. If deficiencies in the establishment of temporary vegetation cover are discovered, the Environmental Inspector will develop a plan of remediation and implement that plan. All erosion control devices are to remain in place and in a functional condition until stabilization is achieved.

#### 7.8.4 Compensatory Mitigation Program

In addition to the mitigating measures which will be implemented during construction and operation of the pipeline to minimize environmental impacts, a compensatory mitigation program will be provided to offset potential impacts in the vicinity of the Gran Chaco National Park. The pipeline will mark the northern boundary of the Gran Chaco National Park, and will be adjacent to the boundary of the Integrated Management Area. Secondary impacts of the pipeline may include the risk of colonization of areas in and around the park due to the establishment and maintenance of the right-of-way. These impacts may affect the physical environment, biological, and human environment.

**Impact:** Alteration of biological habitat, increased hunting pressure, potential colonization pressure in the Gran Chaco National Park and other undisturbed areas.

**Duration:** Temporary and Permanent.

**Benefits:** Biological and cultural resources.

**Character:** Prevention, compensation.

**Description:** The Project Sponsors will propose a contribution to the endowed fund for the park as an offset mitigation for direct and potential indirect impacts of the project. Revenues from the contribution will be earmarked for management of the parks in the Department of Santa Cruz funded through this program. Administration of the funds will be managed by the National Secretary of Natural Resources and the Environment.

Other compensatory action which will also be taken in conjunction with the Bolivia to Brazil Gas Pipeline Project (Bolivian portion) includes the following:

**Impact:** Alteration of socioeconomic environment.

**Duration:** Permanent.

**Benefits:** Cultural resources, water resources, socioeconomics.

**Character:** Compensation, improvements.

**Description:** The project will require the establishment of water wells and generators at different locations. During detail design, provisions will be incorporated to the extent possible to ensure that these facilities are left for the continuing benefit of the neighboring communities. The additional water and energy sources will help the communities satisfy their growing needs for water and energy.

Provisions will be made to compensate land owners for damages resulting from the project. During final design, a complete assessment of land ownership and agricultural areas will be made in order to carry out any necessary negotiations to compensate anticipated impacts.

#### 7.8.5 Contingency Plan

**Impact:** All biological, physical, and cultural impacts.

**Duration:** Temporary and Permanent.

**Benefits:** All biological, physical, and cultural resources.

**Character:** Prevention, minimization, restoration.

**Description:** If conditions are encountered which require modification of the project, or which require non-compliance to complete the execution of the work, the Environmental Inspector will be notified immediately and work will stop. Upon evaluation of the situation, the Environmental Inspector will implement the following plan:

1. Notify the Chief Environmental Inspector of the situation.
2. Gather data necessary for presentation to the Chief Environmental Inspector and/or project officials to develop an alternative plan.
3. Meet with the Chief Environmental Inspector and any other Inspectors or project officials that the Chief Environmental Inspector deems appropriate.

4. Present the existing conditions preventing the completion of work as originally planned and anticipated duration of the conditions.
5. Develop written and detailed (as necessary) alternative approaches with the appropriate parties (craft inspectors, design engineers, construction engineers, and company officials).
6. Present preferred alternative to regulatory authorities as necessary (if alternative requires modification of license or permit conditions).
7. Brief appropriate construction personnel of change in plans.
8. Execute new approach and monitor for compliance with existing or modified license or permit conditions.

A preliminary contingency plan is presented in Appendix D.

#### 7.8.6 Abandonment Procedures

**Impact:** All biological, physical, and cultural impacts.

**Duration:** Temporary.

**Benefits:** All biological, physical, and cultural resources.

**Character:** Prevention, minimization, restoration.

**Description:** The pipeline is being constructed as part of a contract between the countries of Bolivia and Brazil for the supplies of additional natural gas to Brazil over the next twenty years. No plans for abandonment have been developed at this time.

Should abandonment become necessary, standard industry accepted procedures will be followed. Such procedures typically include removal of sections of pipe where necessary due to exposure or potential conflicts with future use, and capping and abandoning in place sections of pipe where removal is not necessary. Both ends of the pipeline will be disconnected and all openings will be closed and sealed. Where the pipeline is subject to pressures or external forces such as those caused by geologic fault sites



or landslides, the pipe will be filled with an inert material from the local area (if possible) and sealed. Abandonment in place is preferred as a means of limiting environmental impacts.

All equipment from compressor stations will be dismantled and transported to storage or a proposed disposal facility. If appropriate, building structures will be assigned to alternate uses compatible with the station environment. Otherwise, such structures will be demolished and their foundations will be removed to allow site restoration to preconstruction conditions to the extent possible.

## **7.9 COST OF MITIGATION MEASURES**

This section presents a preliminary assessment of anticipated costs associated with the implementation of mitigation measures. Some of the components of the EMP, such as erosion control, constitute standard components of the construction plan and are thus not included as a specific item in this cost estimate. Table 7.1 summarizes the cost of the EMP.

TABLE 7.1 SUMMARY OF ESTIMATED COSTS ASSOCIATED WITH THE IMPLEMENTATION OF THE ENVIRONMENTAL MANAGEMENT PROGRAM					
EMP COMPONENT (CHAPTER SECTION)	MEASURE	UNIT	UNIT COST	NUMBER OF UNITS	TOTAL COST
Erosion Control, Revegetation	Revegetation of aeolic plains at Río San Miguel	Plants	Install plants; one-year survival guarantee included	12 ha (120,000 m <sup>2</sup> )	<b>Total \$180,000</b>
Environmental Inspection	Inspection Plan	Environmental Manager <sup>(1)</sup>	\$13,000/mo.	1 Manager (15 mos)	\$195,000
		Chief Inspector <sup>(1)</sup>	\$9,000/mo.	2 Chief Inspectors (10 mos)	\$180,000
		Inspectors <sup>(1)</sup>	\$7,000/mo.	4 Inspectors (9 mos)	\$252,000
		Trucks	\$3,200/mo.	1 Truck (15 mos) 2 Trucks (10 mos) 4 Trucks (9 mos)	\$227,200
		Fuel & Maintenance	\$750/mo.	1 Truck (15 mos) 2 Trucks (10 mos) 4 Trucks (9 mos)	\$53,250
					<b>Total \$907,450</b>
Compensatory Mitigation	National Park Management	Rangers, facilities, operations, and maintenance	Annual interest contributed toward operational cost	Donation to National Endowment Fund, estimated at 10% yearly return to cover investment and operating expenses	<b>Total \$1,000,000</b>

TABLE 7.1 SUMMARY OF ESTIMATED COSTS ASSOCIATED WITH THE IMPLEMENTATION OF THE ENVIRONMENTAL MANAGEMENT PROGRAM						
EMP COMPONENT (CHAPTER SECTION)	MEASURE	UNIT	UNIT COST	NUMBER OF UNITS	TOTAL COST	
Protection of Wildlife and the Right-of-Way	Signage and Barricade Program	Signs & ROW	\$200/sign	560	\$112,000	
		Barriers & Gates	\$1,400/gate	82	\$115,000	
		<b>Total</b>				<b>\$227,000</b>
Community Relations	Water and Generator donation to the community	Well	\$80,000	4 - San José, Roboré, El Carmen, CABI	\$320,000	
		Pumps and Other	\$25,000	4	\$100,000	
		<b>Total</b>				<b>\$420,000</b>
		Generator (3)	\$76,000	1 - San José	\$76,000	
			\$93,000	2 - El Carmen	\$186,000	
<b>Total</b>				<b>\$262,000</b>		
	Building	\$30,000	1 - Pailón	<b>Total</b>	<b>\$30,000</b>	

TABLE 7.1 SUMMARY OF ESTIMATED COSTS ASSOCIATED WITH THE IMPLEMENTATION OF THE ENVIRONMENTAL MANAGEMENT PROGRAM					
EMP COMPONENT (CHAPTER SECTION)	MEASURE	UNIT	UNIT COST	NUMBER OF UNITS	TOTAL COST
Community Relations	Public Education Program	Professionals	Public Education Manager at \$40/hr	520 hr	\$20,800
			Public Education Trainers at \$20/hr	Two for 520 hr each	\$20,800
		Materials	Miscellaneous supplies and brochure materials	Enough to cover 3,000 people (panphlets)	\$20,000
	<b>Total \$61,600</b>				
	Public Communications Program	Public Communications Officer	One at \$2000/mo	For 2 years	<b>Total \$48,000</b>
<b>Total Cost of Mitigation Measures:</b>					<b>\$3,136,050</b>

<sup>(1)</sup> Salary plus living expenses.

**CHAPTER 8.0**  
**PUBLIC CONSULTATION PROGRAM**

**TABLE OF CONTENTS**

8.1	GENERAL .....	8 - 1
8.1.1	Introduction .....	8 - 1
8.1.2	Purpose .....	8 - 1
8.1.3	Approach .....	8 - 2
8.1.4	Scope .....	8 - 3
8.2	CONSULTATION MEETINGS WITH GOVERNMENT AGENCIES ..	8 - 4
8.2.1	Ministerio de Desarrollo Humano - Secretaría Nacional de Asuntos Etnicos, de Género y Generacionales (SAE) .....	8 - 5
8.2.2	Ministerio de Desarrollo Sostenible y Medio Ambiente - Dirección Nacional de Biodiversidad (DNCB) .....	8 - 7
8.2.3	Ministerio de Desarrollo Sostenible y Medio Ambiente - Secretaría Nacional de Recursos Naturales y Medio Ambiente (SNRNMA) .....	8 - 10
8.2.4	Ministerio de Cultura - Bolivian Institute of Archaeology .....	8 - 12
8.3	CONSULTATION MEETINGS WITH NGO'S .....	8 - 13
8.3.1	Liga de Defensa del Medio Ambiente - LIDEMA .....	8 - 14
8.3.2	Asociación Ecológica Boliviana del Oriente - ASEO .....	8 - 15
8.3.3	Fundación Amigos de la Naturaleza - FAN .....	8 - 16
8.3.4	Confederación de Pueblos Indígenas de Bolivia (CIDOB) .....	8 - 17
8.3.4	Capitanía del Alto y Bajo Izozog (CABI) .....	8 - 25
8.4	PUBLIC MEETINGS .....	8 - 31
8.4.1	Pailón .....	8 - 31
8.4.2	San José de Chiquitos .....	8 - 36
8.4.3	Roboré .....	8 - 39
8.4.4	El Carmen .....	8 - 42
8.4.5	Puerto Suárez .....	8 - 45
8.4.6	Puerto Quijarro .....	8 - 49

**CHAPTER 8.0**  
**PUBLIC CONSULTATION PROGRAM**

**LIST OF TABLES**

<u>TABLE NO.</u>	<u>DESCRIPTION</u>
8.1	SURVEY RESULTS FROM PUBLIC CONSULTATION MEETINGS

## 8.0 PUBLIC CONSULTATION PROGRAM

### 8.1 GENERAL

#### 8.1.1 Introduction

A Public Consultation Program (PCP) was conducted with government agencies, nongovernmental organizations (NGO's), and affected communities during the preparation of the EIS for the Bolivia-Brazil Gas Pipeline project. The PCP was developed to comply with the requirements of the World Bank *Environmental Assessment Source Book* (World Bank, 1991-1995 [1991a, 1993, 1994b]), World Bank Operational Directives 4.01 and 14.70 (World Bank, 1991b and 1989), and International Finance Corporation (IFC) *Environmental Review and Analysis of Projects* (IFC, 1993).

#### 8.1.2 Purpose

Consultation with government agencies and interaction with local NGO's, and affected communities, was viewed as a critical component of project development and EIS preparation. This consultation assisted with identification of possible project impacts, reconciliation of opposing views about the project, discussion of licensing requirements, promotion of understanding of the nature and extent of any social or environmental impacts, and fulfillment of the requirements of Bolivian Law.

Consultation with government agencies at national, regional, and local levels was necessary because of the broad range of responsibilities of such agencies in social and environmental related matters such as water, land use, biological resource conservation, health, etc. In the case of the project, such consultation also reflected the position of the Government of Bolivia as a major participant in the project.

Consultation with local NGO's and affected communities was essential to gain a proper understanding of the nature and extent of social and environmental impacts that may result from

the development of the project and to seek inputs from those communities in the development and implementation of appropriate mitigation measures.

### 8.1.3 Approach

The approach followed for the PCP consisted of a series of visits and public meetings with government ministries, local NGO's based in the cities of La Paz and Santa Cruz, local communities settled in the general vicinity of the proposed Bolivia-Brazil Gas Pipeline Project and organizations of indigenous peoples. The program was completed from May 15 through May 24, 1996. The PCP Team consisted of sponsor representatives from Yacimientos Petrolíferos Fiscales Bolivianos (YPFB), Enron, and the BTB Group (Tenneco Energy, British Gas, and BHP), and specialists from Dames & Moore.

The meetings with government officials followed an interactive approach to identify and discuss the main environmental matters associated with the project. During these meetings the project was explained to representatives of different ministries and the position of the Government of Bolivia was also discussed. These meetings were also used to gain a better understanding of the requirements of Bolivia's new environmental law and the status of the environmental license previously obtained for the project.

The meetings with local NGO's followed an interactive approach to identify and develop an understanding of key issues that should be addressed in the EIS. In addition, these meetings were used to communicate an understanding of the project and EIS analysis process to meeting participants to support the public review process. During these meetings discussions were also held to clarify any misconceptions and expectations associated with the project and provide project-specific knowledge to NGO's participants.

The public meetings effort was initiated by sending written invitations to public officials and principal business leaders in the local communities. In addition, public notices were posted and placed in several conspicuous places in each community several days prior to the meetings. At each meeting there was a formal presentation of the project, brochures were distributed providing project information, and there was an open forum question and answer period. In conjunction



with the public meetings, questionnaires were distributed to all participants to gather supplemental information on the socioeconomic baseline conditions of each community and the concerns of the people. The team sociologist also conducted a series of random individual interviews in each of the communities.

Following the public meetings, a private reception was held for public officials and principal business leaders to provide additional interaction between local officials and the Project Team. The Team also met with the Subprefecto of the Chiquitos and German Busch Provinces. This opportunity was used to gather additional information about the socioeconomic structure of the communities. During the course of the visit to each community the Project Team observed the local infrastructure including schools, hospitals, water and electrical facilities, visited with local utility companies, and developed a better understanding of the local resources.

#### **8.1.4 Scope**

The scope of work of the PCP included the following tasks:

- Development of a project brochure that summarizes the technical components of the project along with the main environmental and socioeconomic issues. A total of 900 brochures were distributed in the public meetings. A copy of the project brochure is included in the Appendix.
- Preparation of two socioeconomic questionnaires designed to gather supplemental information for the socioeconomic conditions chapter of the EIS. Six copies of a long version questionnaire were distributed to the local authorities of each town. A total of 301 copies of a short version questionnaire were collected during the public meetings. Results of the project questionnaires are summarized in Table 8.1.
- Four consultation meetings with government officials to discuss the project related environmental and socioeconomic matters and identify the range of environmental and socioeconomic issues to be included in the EIS.

- Five meetings with local NGO's to identify and develop an understanding of key issues that should be addressed in the EIS and communicate an understanding of the project goals and objectives.
- Six public meetings attended by approximately 800 people to gain a broad understanding of the environmental and socioeconomic setting of the pipeline corridor, local communities, and surrounding area.

## 8.2 CONSULTATION MEETINGS WITH GOVERNMENT AGENCIES

The public consultation program included meetings with four government agencies. These meetings served as a forum for exchanging information related to data that could be made available for the EIS preparation, describing the organizational structures of the ministries and past experiences in-country which may be of relevance or interest to the project. Ministry representatives were shown copies of pipeline route maps and other project related materials. Discussions were held regarding project specific items and related matters, including applicable legislation. Additionally, some issues and areas of concern in relation to the project were raised by meeting participants.

- Ministerio de Desarrollo Humano - Secretaría Nacional de Asuntos Etnicos, de Género y Generacionales - SAE (Ministry for Development of Human Issues - National Secretariat for Ethnic, Generic and Generational Issues).
- Ministerio de Desarrollo Sostenible y Medio Ambiente - Dirección Nacional de Biodiversidad - DNCB (Ministry of Sustainable Development and Environment - National Directorate of Biodiversity).
- Ministerio de Desarrollo Sostenible y Medio Ambiente - Secretaría Nacional de Recursos Naturales y Medio Ambiente - SNRNMA (Ministry of Sustainable Development and Environment - National Secretariat of Natural Resources and the Environment).

- Ministerio de Cultura - Instituto Bolivia de Arqueología - IBA (Ministry of Culture - Bolivian Institute of Archaeology).

A summary of the topics discussed in these meetings is presented as follows:

### **8.2.1 Ministerio de Desarrollo Humano - Secretaría Nacional de Asuntos Etnicos, de Género y Generacionales (SAE)**

SAE is the National Secretariat for Ethnic, Generic and Generational Issues, which is a division of the Ministry for Development of Human Issues. This meeting took place on May 15, 1996 at SAE's offices in La Paz. Attendees to the meeting included:

Jim Alexander - Enron  
Kay Beasley - Tenneco/BTB  
Laine Powell - Enron  
Luz Maria Calvo Carmona - SAE  
Silvia Urrutia - SAE  
Carlos Méndez - Dames & Moore  
Enrique Escobar Ayoroa - YPFB  
Mojjes Gutierrez R. - SAE  
Victor Ramos Gutierrez - SAE

- The meeting began with an introduction of the team and its purpose to Ms. Calvo, Sub-Secretaria de Asuntos Etnicos, and the other members of the Ministry. This discussion was followed by an explanation of the project including technical issues and benefits.
- The project presentation was followed by an explanation of the EIS, the background, purpose, objectives, and the current schedule. Emphasis was placed on the socioeconomic studies and the consultation program.
- The schedule of the public consultation program was discussed along with the itinerary for the visits to each of the towns. Ministry representatives indicated that it would be

important to involve the Capitanía del Alto y Bajo Izozog (CABI) settlement in the presentation programs. Although CABI was included in the presentation to CIDOB in Santa Cruz, the Ministry recommended that a separate meeting with CABI and possibly a visit to their territory be considered. They recommended that the meetings in the towns be open to the public.

They also indicated that they would like to be able to review the socioeconomic information that is going to be gathered and put together as part of the EIS. At the end of the meeting they expressed an interest in sending a representative from this Ministry with the project team giving the public participation presentations. It was agreed that Mr. Ramos would travel with the Project Team to meet Pailón and CIDOD representatives on Friday and Saturday.

- The meeting was followed by a question and answer period. Most of the questions and concerns were related to the consultation program and other social issues that included how the program was structured and what kind of information we planned to give to the public. They also wanted to know if we were going to give an opportunity to the public to ask questions and to express concerns or if it would be a one-way presentation where we only give our view of the project. We indicated that it would be a two-way program, and that there would be a specific question and answer period.
- We discussed the questionnaire that had been developed and how the purpose of the meeting was not only to give a presentation but also gather additional information required to supplement the EIS. Ms. Calvo commented that she was very pleased with the effort we were making to meet with the Ministry and involve them at this early stage of the project. She believed this would be an excellent example for other projects to see how the public should be given access to project information.
- In summary, the meeting was very positive, and Ms. Calvo expressed an interest in continuing dialog with the Project Team as the project proceeds.

## 8.2.2 Ministerio de Desarrollo Sostenible y Medio Ambiente - Dirección Nacional de Biodiversidad (DNBCB)

DNBCB is the National Directorate for the Conservation of Biodiversity, which is a division of the Ministry of Sustainable Development and Environment. This meeting took place on May 15, 1996 at DNBCB's offices in La Paz. Attendees to the meeting included:

Jim Alexander - Enron  
Kay Beasley - Tenneco/BTB  
Carlos Méndez - Dames & Moore  
Enrique Escobar A. - YPFB  
Laine Powell - Enron  
Rigoberto Sossa - DNBCB  
Boris Fernandez - DNBCB

- Mr. Sossa apologized for the absence of Ms. Alexandra Sanchez de Lozada who was unable to attend the meeting as planned, due to the unexpected necessity of her attending meetings in Europe with the President of Bolivia. Mr. Sossa is National Chief of Protected Areas reporting directly to Ms. Sanchez. The other representative of the Ministry was Mr. Fernandez who is an engineer with the Ministry.
- The project team members were introduced and the purpose of the meeting was stated. Mr. Mendez had met with Ms. Sanchez de Lozada previously, and this follow up meeting was proposed at that time.
- The project team gave an overview of the project, including Enron's role in the project and the activity of the company in other areas of the world. The participation of Petrobras and the BTB group in the project was stated and status of financial aspects were reviewed.
- Mr. Sossa explained how the Ministry was organized. Operations are divided into three units; Protected Areas, Wildlife and Genetic Resources. He said that the protected areas are divided into six different categories. The three most important are reserves for the

protection of biodiversity, national parks and integrated management areas. The Grand Chaco National Park and other protected areas are managed by a Director under DNCB supervision. The parks are typically managed through management contracts with private non-profit organizations and local communities which fulfill necessary minimum requirements. Where no such organization exists, the DNCB can undertake the management of the area directly.

- The financing of park administration is managed by DNCB based on available endowment funds. At the present time they have \$6 million dollars in the fund, and they are using the interest on this money to administer the parks. They plan to increase this fund to \$15 million dollars with funds provided by the World Bank. They hope to later increase the fund to \$30 million dollars, which would provide sufficient interest from the fund to manage the existing park areas.
- The relationship of the pipeline right-of-way and the limits of the National Park and the Integrated Management Areas of the Grand Chaco Park was discussed. The project team explained that the pipeline right-of-way is outside of the park and contiguous to the northern boundary of the park. The discussion also involved the interpretation of Presidential Decree No. 24122 with respect to the status of the right-of-way in relation to the Integrated Management Area.
- The potential scenarios discussed were: 1) that the right-of-way represents an independent area that divides two categories of protected land, the park and the integrated management area (under this interpretation, the pipeline right-of-way would be outside the park and the management area), and 2) that the right-of-way is within the integrated management area and has a zoning classification compatible with the construction and operation of the gas pipeline (Article 3 of the Decree states that the park will develop special zoning designations compatible with the dual purpose of the area: conservation and protection on one hand, and sustainable development on the other hand).

It was noted that both the park and the integrated management areas were established after the alignment of the pipeline was determined and that the pipeline alignment was used a

physical border between the two protected areas. Mr. Sossa indicated that his office would review the two possible scenarios and that YPFB would be advised which one represents the official interpretation of the Ministry.

- The Law states that the management areas are for the use of the natural renewable resources, particularly for the benefit of the local communities. The Ministry was requested to provide some insight as to the definition of how these areas would be managed. Mr. Fernandez explained that the purpose of the integrated management areas is to provide a controlled area for the local inhabitants to conduct activities such as hunting, agriculture, logging, and other life-sustaining activities. The integrated management areas would be utilized to promote these activities outside the protected park reserve and manage the available renewable resources to sustain the life of the local indigenous people.
- Additional emphasis was placed on the importance of the Project Team talking to the CABI community and asked that they be included in a meeting.
- The Ministry was concerned about the location of compressor stations and whether one might be located within the Park or the Management Area. The project team explained that one station will be located on the west side of the park, but would not be within the protected park area.
- Another issue discussed was the importance that communities receive environmental education programs. Mr. Sossa explained that other educational programs were underway. Dr. Andrew Taber with the Wildlife Conservation Society has started a program locally, and has had good response. The project team stated that the EIS will consider an environmental education program.
- Finally, the Ministry explained that a map of protected areas in Bolivia, at a scale of 1:1,000,000 is being developed which will be available for distribution in approximately 30 days from the date of the meeting. The project sponsors agreed to have additional interaction within the next few weeks.

### **8.2.3 Ministerio de Desarrollo Sostenible y Medio Ambiente - Secretaría Nacional de Recursos Naturales y Medio Ambiente (SNRNMA)**

SNRMA is the Secretariat of Natural Resources and the Environment which is a division of the Ministry of Sustainable Development and Environment. This meeting took place on May 16, 1996 at SNRMA's offices in La Paz. Attendees to the meeting included:

Jim Alexander - Enron  
Kay Beasley - Tenneco/BTB  
Carlos Méndez - Dames & Moore  
Enrique Escobar - YPFB  
Raul Lora Rocha - SNRNMA  
Rodolfo Barriga - SNRNMA

- Mr. Lora stated that Bolivia had adopted a new policy for sustainable development. The four objectives of the policy are: 1) economic growth, 2) social equality, 3) rational use of environmental resources, and 4) administrative organization.
- Mr. Lora also discussed the five areas in which they had made major changes in order to accomplish the following objectives: 1) capitalization, 2) educational reforms, 3) new laws such as Environmental Law 1333, protection of the forest, conservation of biodiversity, the new Hydrocarbon law, 4) the administrative requirement for public participation in new projects, and 5) decentralization of the government whereby there is a delegation of authority by the federal government to local governments.
- Mr. Lora then presented a sustainable development model, summarizing the activities in which the Ministry is involved. Mr. Lora stated that Bolivia now has a central government, nine state administrations and 311 municipalities. He identified two major problems in Bolivia: widespread poverty and the isolation of individuals from the economic process. The Ministry's goal is to support this project without compromising any of the new objectives of the government.



- Following Mr. Lora's presentation, the discussion was centered on the licensing requirements for the Bolivia-Brazil Gas Pipeline project. We explained that a license had been issued for the project in 1991, based upon the EIS performed by CUMAT. Since that time the scope of the project has changed in some aspects and new environmental laws have been passed in Bolivia.

The project team explained that an updated EIS being prepared, based upon the new project scope and regulatory guidelines. The Subsecretary then indicated that the proper procedure would be to pursue renewal of the original license. Under the new Law, if a project does not commence activity within twelve months from issuance of the license, the license must be renewed. This process will require submittal of the Ficha Ambiental (Environmental Card) and submittal of the updated EIS.

- Bolivian Law requires that the government provide comments to the Project Sponsor within 30 working days. However, due to the magnitude of the project and the limited Ministry staff, the schedule was modified as follows:
  - June, 1996 - Submit Ficha Ambiental to Ministry
  - August or September, 1996 - Make site visit with Ministry
  - September 1, 1996 - Submit Supplemental Environmental Impact Assessment to Ministry
  - October 15, 1996- Receive comments from Ministry
  - November 15, 1996- Submit supplementary data and revisions to Ministry
  - December 15, 1996 - Receive approval from Ministry
  - December 20, 1996 - License (DIA) issued for project
- It was agreed that Ministry representatives would make one field reconnaissance visit in August or September. With regard to the number of copies of the EIS required by the Ministry, they requested an advance copy of the English version as soon and this becomes available for distribution and two copies of the Spanish translation.

- The Subsecretary also strongly suggested that it would be very important to the project to involve the local government and local Mayor in the city of Santa Cruz in the project presentation program.

#### **8.2.4 Ministerio de Cultura - Bolivian Institute of Archaeology**

IBA is the Bolivian Institute of Archaeology, an organization within the Ministry of Culture. This meeting took place on May 15, 1996 at IBA's offices in La Paz. Attendees to the meeting included Carlos Méndez and Marie Lissette Canavesi Rimbaud of Dames & Moore.

- The purpose of the meeting with the Institute was to ascertain if there were any known archaeological or cultural resource areas within the area of the pipeline corridor. The representatives of the Institute indicated that for any construction work to be authorized in Bolivia, a permit from the Institute is required. To obtain this permit, the project sponsors must write a letter to the Institute requesting identification of any archaeological or cultural resources in the project vicinity.

This permitting process would begin with a literature evaluation prior to construction. They indicated that even if there is no evidence of sites in the literature, a site evaluation performed by the Institute would be required. They would send archaeologists to perform shovel tests along the pipeline right-of-way every 20 to 40 kilometers to determine if there is any ground evidence of archaeological or cultural resources in the area.

Upon completion of the field survey, if no evidence was found, the Institute would issue a letter stating that there are no archaeological resources in the area. They were questioned as to whether this was a legal requirement. They indicated that it was a legal requirement, but the information provided did not substantiate a requirement for any field studies.

- The representative of the Institute also indicated they would require a full-time archaeology team from the government paid by the project on site during construction. However, the regulations provided by the Institute only indicated prohibition of destruction of cultural

resources during construction. Additional research into this matter needs to be completed; however, it appears that an archaeological contingency plan for construction will be adequate to meet Bolivian regulations.

- The Project Team intends to discuss the matter with Mr. Raul Lora, Environmental Subsecretary with the Sustainable Development and Environment Ministry, and ask him to contact Messrs. Alberto Bailey and Carlos Ostermann, upper management with the Institute, to clarify the Bolivian requirements for archaeological review for a project of this magnitude.

### 8.3 CONSULTATION MEETINGS WITH NGO'S

The public consultation program included meetings with five Non-Governmental Organizations (NGO's). These meetings served as a forum for exchanging information related to the environmental and socioeconomic aspects of the project and for describing the organizational structures of the Project Sponsors and the NGO's. NGO's representatives were shown copies of pipeline route maps and other project related materials. Discussions were held regarding project specific items and related matters, including applicable legislation recently ensued. Additionally, a few issues and areas of concern in relation to the project were raised by meeting participants. The meetings took place with representatives of the following NGO's:

- Liga de Defensa del Medio Ambiente - LIDEMA (Association for the Defense of the Environment).
- Asociación Ecológica Boliviana del Oriente - ASEO (Ecological Association of Eastern Bolivia).
- Fundación Amigos de la Naturaleza - FAN (Friends of the Environment Foundation).
- Confederación de Pueblos Indígenas de Bolivia - CIDOB (Confederation of Indigenous Peoples of Bolivia)
- Capitanía del Alto y Bajo Izozog - CABI (Submunicipality of the Izozog highlands and Lowlands).

A summary of the topics discussed in these meetings is presented below.

### 8.3.1 Liga de Defensa del Medio Ambiente - LIDEMA

LIDEMA is the Association for the Defense of the Environment. This meeting was held at LIDEMA's headquarters located in La Paz on April 16, 1996. Attendees to the meeting included:

Laine Powell - Enron

Kay Beasley - BTB/Tenneco

Carlos Méndez - Dames & Moore

Dr. Luis Alberto Rodrigo - LIDEMA

- Mr. Powell presented the project history and the technical aspects of the project and discussed economics and the financial and political aspects and the importance of the project to Bolivia. He also addressed the YPFB association with Enron.
- Mr. Mendez provided an overview of environmental issues, which focused on two areas, one was biological-ecological, and the second was socioeconomic. The presentation identified what is generally included in an EIS, the Supplemental EIS for this project, and the purpose of the presentation and the meeting.
- Dr. Rodrigo provided an overview of LIDEMA's organization and administrative structure and discussed LIDEMA's main objectives.

Following the presentation, there was a discussion/question and answer period. The questions, issues, and concerns address during this period are summarized below:

- Question: What provisions will the project take to control colonization of areas located adjacent to the new roadways and to the right-of-way corridor.

*Answer: The response was that 1) the project intends to use only existing access roads which are already connected to the right-of-way, and 2) the right-of-way will not constitute a permanent road. After construction, the right-of-way will transformed into a*

*maintenance path where vegetation will be allowed to grow. The right-of-way will have a limited number of gates.*

- Concern: Mr. Rodrigo indicated that gates will not work and suggested that actual ditches are built across the right-of-way at different locations to discourage the passage of regular vehicles. He explained that this method have been used in Africa with good results.

*Answer: The response was that the design team will consider the suggested method as another means to control colonization.*

### **8.3.2 Asociación Ecológica Boliviana del Oriente - ASEO**

ASEO is the Ecological Association of Eastern Bolivia. This meeting was held at ASEO's offices in Santa Cruz on April 18, 1996. Attendees to the meeting included:

Jim Alexander - Enron  
Kay Beasley - Tenneco/BTB  
Juan Tavolara - YPFB  
Carlos Méndez - Dames & Moore  
Jurgen Reppke - ASEO

- Mr. Tavolara presented the project history and the technical aspects of the project and discussed economics and the financial and political aspects and the importance of the project to Bolivia. He also addressed the YPFB association with Enron.
- Mr. Mendez provided an overview of environmental issues, which focused on two areas, one was biological-ecological, and the second was socioeconomic. The presentation identified what is generally included in an EIS, the Supplemental EIS for this project, and the purpose of the presentation and the meeting.
- Mr. Repkee provided an overview of ASEO's organization and administrative structure and discussed ASEO's main objectives.

Following the presentation, there was a discussion/question and answer period. The questions, issues, and concerns address during this period are summarized below:

- Question: What provisions will the project take guarantee public safety related to possible gas releases to the atmosphere and potential explosions.

*Answer: The response was that 1) the pipeline will be underground along the entire alignment and thus the potential for accidents involving vehicular crushes did not exist, 2) the pipeline will have safety valves located every 32 Km which will be designed to close a pipeline segment where a reduction in gas pressure is detected, 3) the project will include a Contingency Plan designed to establish the necessary guidelines in case of a contingency, 4) the safety statistics of gas transmission pipelines is one of the best in the energy transmission industry.*

- Question: What provisions will the project take to control colonization of areas located adjacent to the new roadways and to the right-of-way corridor.

*Answer: The response was that 1) the project intends to use only existing access roads which are already connected to the right-of-way, and 2) the right-of-way will not constitute a permanent road. After construction, the right-of-way will transformed into a maintenance path where vegetation will be allowed to grow. The right-of-way will have a limited number of gates.*

### **8.3.3 Fundación Amigos de la Naturaleza - FAN**

FAN is the Friends of the Environment Foundation. This meeting was held on April 16, 1996 at FAN offices in Santa Cruz. Attendees to the meeting included:

Jim Alexander - Enron

Kay Beasley - Tenneco/BTB

Juan Tavolara - YPFB

Carlos Méndez - Dames & Moore  
Hermes Justiniano - FAN

- Mr. Tavorara presented the project history and the technical aspects of the project and discussed economics and the financial and political aspects and the importance of the project to Bolivia. He also addressed the YPFB association with Enron.
- Mr. Mendez provided an overview of environmental issues, which focused on two areas, one was biological-ecological, and the second was socioeconomic. The presentation identified what is generally included in an EIS, the Supplemental EIS for this project, and the purpose of the presentation and the meeting.
- Mr. Justiniano provided an overview of FAN's organization and administrative structure and discussed FAN's main objectives.
- Mr. Justiniano indicated that his main concerns with the project were: 1) that the Chaco is one of the richest areas in Biodiversity and that as such, any project in this area requires a sound environmental management plan, and 2) that the bañados del Otuquis should have protection status as a national park.
- Mr. Justiniano also indicated that although he believes the Bolivia-Brazil pipeline project is very important for Bolivia, this project should be used to set up precedent in the development of meaningful environmental management plans for major projects. He added that major projects should contribute to the improvement of life conditions of the nearby communities.

#### **8.3.4 Confederación de Pueblos Indígenas de Bolivia (CIDOB)**

CIDOB is the Confederation of Indigenous Peoples of Bolivia. The presentation was given on Saturday, May 18, at the CIDOB headquarters in Santa Cruz. Attendees to the presentation included:

Jim Alexander - Enron  
Kay Beasley - BTB/Tenneco  
Juan Tavolara - YPFB  
Enrique Escobar - YPFB  
Carlos Méndez - Dames & Moore  
Marie Lissette Canavesi Rimbaud - Dames & Moore  
Javier Olmedo - Dames & Moore  
Victor Ramos G. - Secretaría Nacional de Asuntos Etnicos  
Rodolfo Barriga - Subsecretaria de Media Ambiente

- Mr. Rodolfo Barriga Estenssoro with the Sustainable Development and Environmental Ministry, and Mr. Victor Ramos Gutierrez with the Planning Department of the Ministry of Human Development also attended the meeting.
- Mr. Valentin Muiba, the local leader of the Indigenous people in Santa Cruz introduced the group, welcomed the participants, and explained to the indigenous leaders the purpose of the meeting.
- Mr. Tavolara presented the project history and the technical aspects of the project.
- Mr. Escobar discussed economics and the financial and political aspects and the importance of the project to Bolivia. He also addressed the YPFB association with Enron.
- Mr. Mendez provided an overview of environmental issues, which focused on two areas, one was biological-ecological, and the second was socioeconomic. The presentation identified what is generally included in an EIS, the Supplemental EIS for this project, and the purpose of the presentation and the meeting.

Following the presentation, there was a question and answer period. The questions asked are summarized as follows:



- Question: The first question had to do with the safety of the gas pipeline in residential areas, especially related to the communities located in the eastern third of the Bolivian sector, after El Carmen. They wanted to know what the risk was of having a safety problem which might affect the community.

*Answer: The response was that 1) the pipeline will be buried so there will be no concern about cars or other vehicles damaging the pipeline or causing a rupture, 2) safety valves located every 32 kilometers would shut in the system automatically in the event a loss of pressure is detected, and 3) the Environmental Impact Assessment will include a contingency plan that will specify the response program to be followed in the event of a gas leak.*

Question: The second question related to colonization and human settlement resulting from opening of the right-of-way along the pipeline, especially in the area of the Gran Chaco Park. One individual asked what the project would do to prevent this problem.

*Answer: The only existing access roads would be used, no new access roads would be built, half the right-of-way width would be returned to the environment, and within the 17 meter permanent right-of-way no traffic will be allowed. A road would not be left, only a path for maintenance operations, and the project was going to consider a cooperative effort with the Park management to control the use of the pathway.*

- Question: What contamination would result from a gas leak under any one of the three rivers traversed by the pipeline?

*Answer: We explained that in the event of a leak, gas would pass through the water into the atmosphere. It would not mix with the water. Also, the pipeline would have low pressure actuated shut-off valves on either side of the river which would stop gas flow and isolate the area should a pressure drop occur.*

- Question: This question had to do with the possibility of having the project install gas to the towns for industrial use and power generation. The question specifically addressed service to towns in close proximity to the pipeline for reliable power generation.

*Answer: We responded that this was technically possible, a valve could be installed when market conditions justify the investment for such a connection. The project did not include such a valve at this time, but this could be considered in the future.*

- Question: One individual wanted to know what measures the project would have to control hunting during construction and how hunting could be discouraged, reported and controlled.

*Answer: Hunting by construction personnel will be forbidden. Anyone who violates this rule will be terminated. In addition, the EIS will recommend that an individual or group be designated as a personal contact to handle any problems or concerns the public might have, and the people will be advised as to who that contact person is.*

- Question: This question had to do with economic impacts in relation to the financial benefits the project would generate for distribution in each one of the states that produce gas. Based on an estimated 32% gas tax, they questioned how much would be distributed to the states that would produce the gas.

*Answer: 11% was the number that was given to them for the producing states and 1% for Pando and Beni.*

- Question: Will there be compensation for the value of crops being grown by indigenous people on property for which they do not have legal title or papers?

*Answer: The project would pay a fair market value for the economic impact to agricultural crops regardless of whether or not the people had papers.*

- Question: This question was related to the current status of the project, the status of the EIS, why the presentation was not given prior to this time, and if it was possible for the project sponsors to submit a copy of the environmental report to CIDOB so they could have the opportunity to review the information presented in the report.

*Answer: The project was still in the planning stage and construction had not started. The EIS was approximately 50% complete, and we anticipate that the study will be submitted to the Ministry for review on September 1. It was not possible to hold the meeting prior to this time because there was no study and information was not available to appropriately discuss the project. We offered to provide them with environmental information, but did not offer to send the entire report.*

- Question: This question was asked by a leader from the Argentine border region who lived in Villamontes close to the Pilcomayo river. He indicated that the pipeline to Argentina ran close to their community and that although they had no negative impacts from the pipeline, there were no positive impacts either. They had hoped that the project would bring good things to the area, but nothing happened. At the same time, he was open to recognize that the pipeline was underground and that it didn't bother anybody. It was understood that the benefits to the community would come through the municipalities. He asked who he could go to if the mayors did not properly manage the funds.

*Answer: He was told that the new Public Participation Law has some control features which allow the local people to organize and create a controlling unit that would oversee all the actions that a mayor or authority is undertaking.*

- Question: In addition to employment opportunities and a temporary improvement in the economy of the towns, what benefits could the project give to areas adjacent to the project?

*Answer: The response was again to stress other benefits of the project such as the taxes that would come back through the public participation law and the improvement of some*

*of the local infrastructure that would be required by the project. It was also explained that this project was of national importance and as such it was not possible to add supplementary projects to benefit regional areas. The purpose of the project was to sell gas and make it profitable so the project could be built. If other objectives were added, it could reach the point that the project is not feasible, and it will not be built.*

- Question: This question was asked by an individual from Roboré who inquired as to whether labor opportunities in the project would be only in the technical field, or if there might be opportunities for unskilled labor.

*Answer: It was explained that there would be ample opportunity for utilization of unskilled labor.*

- Question: This question was related to the number of opportunities that the project might generate with respect to unskilled labor, and to whom they might go with questions about project opportunities.

*Answer: There would be many opportunities for unskilled labor, particularly in the camps, such as cooks, laundry workers, and other types of maintenance personnel. This would be handled through subcontractors in the project. The mitigation and social management plan in the EIS will recommend that a separate department within the project team be formed to take care of any socioeconomic issues and provide a contact source for any questions or complaints the people might have. This social communications person or group of people would be able to respond to issues which the communities feel are not in accordance with their expectations, or any problems the project is creating for them.*

- Question: In addition to this effort to inform the communities that are going to be affected by the project, what other organizations have the project sponsors contacted to inform and get opinions about the project? In particular, they were interested in COB, the general union organization in Bolivia which deals with labor issues.

*Answer: We explained to them that after the study is finished, the report would be submitted to the Ministry, and it would be available to the public so that anyone who wanted information about the project could review the report.*

- Question: It was asked if the project could provide the gas required for generators to enable the closest towns to the project to have electricity twenty-four hours a day. They asked who they might contact to follow up on this, YPFB or CIE (rural electricity cooperative which takes care of extending electricity networks into the rural areas).

*Answer: We told them that technically it was possible, but this was not part of the current project scope. We advised them to contact CIE.*

- Question: What possibility exists that the treaty between Bolivia and Brazil to buy and sell gas could stimulate significant settlement by the Brazilians in the Santa Cruz area which could promote colonization or even promote armed conflict between the two countries?

*Answer: Our response was that we did not see anything in the project or the contract that would encourage the Brazilians to invade Bolivia. It was a clear-cut agreement for one country to produce gas and transport it to the border for sale to the other for a given price.*

- Question: Does Bolivia have sufficient capacity to produce gas to ensure the gas supply needs of Bolivia can be met in the future, and what procedure will be used to measure the volumes to be sold to Brazil?

*Answer: Gas could be brought to Bolivia from Argentina or possibly Peru, and a measuring station would be set up at the border to measure gas sold.*

- Question: This question was related to the possibility for project sponsors to have meetings every six months with indigenous settlements through CIDOB to provide an update on project activities. They also asked if it was possible for the project sponsors

to have the same group go to other indigenous communities located in other areas of the country.

*Answer: The response was that it was possible.*

Following the question and answer session, the leader of the indigenous people asked the participants to critique the workshop. The people were asked to identify what was excellent about the workshop, what was good, what was average and what was bad about the presentation.

- The first person indicated that the excellent things were the organization, the quality of the presentation, and the amount of information that was presented during the day.
- The second individual, who was an attorney, felt that the good thing about the workshop was the fact that they were being informed about the cause and effect aspects of the project. She said it was unique for project sponsors to come to them to discuss not only the effects of a project, but also the reasons for doing the project. The bad thing was that the information was being given only to communities located adjacent to the project and not to other communities in other parts of the country. She felt this information should be given all over Bolivia and she suggested that the project sponsors use the newspapers or television to provide the same information presented today to the other sectors of the country.
- The third person said that the good thing was the participation of the project sponsors in the program, the information presented in the workshop and the food. The bad thing was the hot weather.
- The fourth person said the good thing was that we were doing this presentation not only in Santa Cruz, but in other areas as well. They were not happy that for most events people had to come from their towns to Santa Cruz to participate. He praised the project team for going to the small towns and giving the opportunity to people in each town to hear the same thing we presented in Santa Cruz.

### 8.3.4 Capitanía del Alto y Bajo Izozog (CABI)

CABI is the Submunicipality of the Izozog highlands and Lowlands, an indigenous organization of guaranies natives that are settled in 22 communities located along the Parapetí river. The presentation was given on Sunday, May 19, at the Hotel La Quinta in Santa Cruz. The meeting was held with key leaders from CABI, which is the umbrella organization for the Izozeño Indigenous peoples of the Chaco. The CABI organization was instrumental in establishing the Spirits of the Chaco National Park and Integrated Management Area, which was officially authorized by signing of a Bolivian Presidential Decree in September, 1995. Attendees to the meeting included:

Jim Alexander - Enron

Kay Beasley - BTB/Tenneco

Juan Tavolara - YPFB

Enrique Escobar - YPFB

Carlos Méndez - Dames & Moore

Marie Lissette Canavesi Rimbaud - Dames & Moore

Javier Olmedo - Dames & Moore

Victor Ramos G. - Secretaría Nacional de Asuntos Etnicos

Rodolfo Barriga - Subsecretaria de Media Ambiente

The Chaco is one of the largest protected areas in South America, and contains the highest mammalian biodiversity on the continent. The route of the Bolivia-Brazil pipeline follows the northern boundary of the Park for approximately 75 kilometers.

The CABI representatives included Juan Aguirre Castro (Gran Chaco Park Director), Marcelino Morales (Chief Park Ranger), Evelio Aranvisa (Project Coordinator) and Bonifacio Barrientos (CABI Grand Captain).

The CABI people were thanked for coming on Sunday morning to discuss the project. The Project Team was then introduced, and the purpose of the meeting presented.

Mr. Tavolara gave a brief explanation of the project. Mr. Méndez discussed the EIS and the relationship of the Gran Chaco Park to the project.

Following the presentation by the project team, the CABI representatives gave a brief overview of their organization and provided some historical background of the Gran Chaco Park. Mr. Barrientos explained that CABI is the first legally established Indigenous Sub-Municipality in Bolivia. Their jurisdiction is the Alto and Bajo Izozog (the highland and lowland areas of the Izozog). The Bañados del Izozog represents an area of interest from an environmental perspective, and is the area where the natural resources for survival of the Izozeños are concentrated. They have a special interest in the Gas Pipeline Project and how it will impact this area.

Mr. Evelio Aranvisa then described the origination of CABI, how the Public Participation Law affected their activities, and how the Protection Law of the Gran Chaco Park was instigated by the CABI people. He emphasized that establishment of the Park was not a government effort, but driven by the desire of the CABI people to have a protected area to conserve their homeland.

He also explained that one of the primary reasons for creating the Park was to fight the uncontrolled expansion of large agricultural areas instigated by urban development. He explained their struggle to gain administration of the Park from the government. In the discussion, he explained that CABI had proposed creation of the Park in 1990, but it was not until the fall of 1995 that the law creating the Park was signed by the government.

Two months after the Park was established, CABI signed a contract with the Bolivian government for administration of the Park. CABI has three main programs in the administration of the Park. The first one is the control of the Park, which has received some financing from the World Bank. The second program is a community mapping program for sustainable development to protect their primary sources of livelihood, which are hunting, fishing, and agriculture. Their third program is a natural resources planning program which focuses on the protection of biodiversity.

With regard to organization, CABI is a local organization comprised of 22 communities located along a 100 km stretch of the Parapeti River. The 22 groups which belong to CABI are as follows:



Isiporenda	Rancho Nuevo
Carapari	Mini
Koperay Guasu	Yugui
Kopere Montenegro	San Silvestre
Kopere Brecha	Tamane
Kopere Loma	Cuarirenda
Capeatindi	Aguaraty
Yapiroa	Coropo
Ivasiriri	Yobi
La Brecha	Aguarayba
Tamasindi	Rancho Viejo

After the war between Bolivia and Paraguay for the Chaco region in 1937-39, there were only 800 people in these communities. In 1972 there were 3,500 people, and in the 1992 census were 7,500 people. They estimate that in 1996 there are 8,000 people. Mr. Aranvisa indicated that the three main groups in the area are the Chiquitanos, Ayoreos, and the Guaranis. CABI belongs to the Asamblea del Pueblo Guarani (APG), which is a regional organization of all Guarani settlement groups or towns. APG then belongs to CIDOB, which is the national organization of indigenous settlements.

CABI has an annual meeting of 200 delegates in which the administration gives information about the previous year's programs, explains how funds were administered, and presents a budget for the following year. CABI has a traditional justice system, without police. They have a Grand Captain, "mburubicha guazu", who has authority over the 8,000 people. The Grand Captain is currently Mr. Bonifacio Barrientos. They have two vice-captains, one responsible for the high areas of the Izozog, and the other responsible for the low areas. Each group has four assistants, and there are representatives from each of the communities.

They explained that their democratic system is based upon the Popular Participation Law. To win an election requires a consensus in which there is unanimous agreement on the people to be elected. Discipline for civil or criminal injustice is administered by the Grand Captain. In extreme cases people are excommunicated or banned from the community.

In 1990 the central government recognized the populations of Indigenous settlements and gave them resources to be used for health, education and development programs, such as clinics, schools, and irrigation. They said their educational programs include bilingual education to teach their children not only castellan Spanish but also Guarani. There is an agreement between CABI and the Normal de Chiragua, a university for teachers which is implementing bilingual educational programs. The school system has 16 schools and 69 teachers, including 60 bilingual teachers and 9 who speak only Spanish.

CABI has been looking at the possibility of developing and coordinating traditional medicine in the area, which is significantly less expensive than western medicine. They have four medicine men in the area, who are called "chamanes". They are involved in research activities and have developed four medications, in conjunction with the University of San Andres in La Paz, which are sold in local hospitals. They have one hospital in La Brecha, four clinics, one doctor and sixteen nurses. They have an agreement with the Red Cross of Switzerland that was set up in the area five+ years ago.

Several other international organizations are active in the area to develop education and training programs to assist the people in understanding better use of the land, including APCOB and Centro de Investigación Agricultura Tropical (CIAT/CIPCA).

The main problems in the area are: 1) chagas, 2) water supply, and 3) transportation. They need a laboratory to study and develop prevention programs for the chagas disease, which is transmitted through an insect. Availability of potable water is a major issue for sustainable development in the area. Eighteen of the communities have water supply from wells, which range in depth from 160-180 meters. Four more wells are needed to provide water to all the communities. Electrical service is available only in La Brecha.

There was some discussion regarding the relationship between the right-of-way and the Park boundaries. It was explained that the gas pipeline would not cross the Park but is going to be built adjacent to the Park. The law creating the Park was issued after the route of the pipeline was determined, and the Park was defined to be south of the pipeline right-of-way. Although the CABI people agreed with this concept, they explained that they estimated that approximately 450

hectares of land would be affected by the 30 meter right-of-way along the 150 kilometers of the pipeline in the Chaco.

The CABI people consider that the gas pipeline from Bolivia to Brazil is a project of national interest, and they do not plan to oppose the project. However, they believe the project should contribute to the operation of the Park.

The third part of the presentation by CABI was given by Mr. Aguirre. He explained that the Park was created with two main purposes, 1) to create a protected area that was by law designated as a National Park, and 2) to designate a management area to be used by the local people. One of the objectives of the management of the Park is to preserve land in the area for agricultural purposes.

They stated that they were looking for the pipeline project to set up a program through an agreement with CABI and the Ministry whereby CABI would be contracted to control access to the Park and provide the environmental inspection for the project area adjacent to the Park before, during, and after construction. They explained that they currently have funds available to support fifteen rangers based in three areas, 1) Natividad, 2) Tita, and 3) Cañado Abaroa.

Based on their studies fifteen rangers are insufficient to control the Park. They believe they ultimately need 45 rangers located in seven different stations to adequately protect the 3.5 million hectare area. In addition, they need all-terrain vehicles, motor vehicles, and related equipment to be able to patrol the area. They hope that the project can finance another group of fifteen rangers which would allow them to better control the resources of the CABI community.

They also discussed some local concerns and expressed the desire to work with the project to resolve some of these issues and protect the area from impacts of the project. One issue of concern is migration into the area by outsiders who settle on the land and claim ownership rights. Another area of concern is the drug traffic from Bolivia to Paraguay and the potential for the pipeline right-of-way to enhance traffic through the Park. They felt that park rangers located in strategic areas would help control these issues.

They were asked to provide a better understanding of how the Park management is funded and how those funds are being managed at the present time. They explained that their financing comes from three different sources: 1) the World Bank through FNMA (\$1,000,000), 2) USAID (\$89,000), which is a program started in April of this year and will extend until August, 1996, and 3) USAID (\$93,000) which is a fund to extend from May until December, 1996.

They said the World Bank allowed them to receive \$400,000 in funds in the first year to implement and operate the 15-ranger program for one year. They explained that the total budget for the World Bank fund was \$8.5 million, to be used for eight different protected areas, including the Chaco.

The total budget for the Gran Chaco Park is approximately \$1 million - \$400,000 for the first year, then \$150-250,000 for years two, three, and four. These funds were allocated to them in 1993, and they were supposed to last until 1997. At this time they have spent 70%, so they still have 30% of the funds which they believe will last until 1998.

The USAID funds include the community mapping previously discussed, development of a plan for use of natural resources, and a management program for the area. These funds would also people. They explained that Dr. Taber's people were not paid by the fund, but by their own organization, the Wildlife Conservation Society. Program funds are audited every three months, and an external audit is performed once a year.

They also told us that they were evaluating other programs that are related to environmental education, tourism, and development projects that would allow them to export plants and animals for medical research to other countries.

With funds provided by the World Bank, they believe they can finance another fifteen rangers, which would give them a total of 30. An additional fifteen rangers are what CABI would like to see financed by the project, to make a total of 45.

## 8.4 PUBLIC MEETINGS

The public consultation program included public meetings in six communities. These meetings served as a forum for exchanging information related to the environmental and socioeconomic aspects of the project and for describing the organizational structures of the Project Sponsors. Maps of the pipeline route and other project related materials were presented to the audience and project brochures were distributed to all attendees. Discussions were held regarding the technical, environmental, and socioeconomic issues related to the design, construction, and operation of the pipeline project. Other related matters included applicable legislation recently ensued. Issues and areas of concern in relation to the project were raised by audience. The meetings took place with representatives in the following communities:

- Pailón
- San José de Chiquitos
- Roboré
- El Carmen
- Puerto Suárez
- Puerto Quijarro

An outline of the discussed items and a brief summary of the approach to dealing with each is set forth below.

### 8.4.1 Pailón

Attendees to the meeting in Pailón on May 17, 1996 included:

Jim Alexander - Enron  
Kay Beasley - BTB/Tenneco  
Enrique Escobar - YPFB  
Juan Tavolara - YPFB  
Carlos Méndez - Dames & Moore  
Laine Powell - Enron

Marie Lissette Canavesi Rimbaud - Dames & Moore

Javier Olmedo - Dames & Moore

- Prior to the public meeting, the project team met with Mr. Humberto Mejia Rocha, the Mayor of Pailón. The Mayor shared with the group some of the history and recent developments in the area. He said that Pailón was established as a municipality only recently, and the position of Mayor is new to the town. Mr. Mejia has been in this administration for the past four months, and basically the policy he is following is to motivate investment in the area without regard to nationality. He stated in many cases a tax incentive can be offered and real estate made available for investors promoting businesses in Pailón.
- According to the 1992 census, the area under the new municipal administration has 12,000 inhabitants, although the Mayor claims that it now has 20,000. The 1992 census listed 3,700 inhabitants in the township itself. These population figures are taken into account to determine the distribution of taxes from the central government compensation fund. After the Mayor spoke, Mr. Powell thanked him for his assistance in coordinating the public meeting.
- Prior to the public meeting, Ms. Canavesi, the group sociologist, worked with the Mayor to complete a questionnaire about the community. Personal interviews were also conducted with several of the town people.
- Ms. Canavesi took a brief tour of the town. There is only one medical center which has five beds and one doctor and one nurse. They have two schools, with a total of 1,700 students. The public school has 1,500 students, and the private school has 200. The public school is in poor condition.
- The public meeting began at 11:00 a.m. and followed the agenda which had been prepared for the public meetings. The Mayor thanked the public for their attendance and introduced the Project Team.

- Mr. Tavolara then discussed technical issues and YPFB's previous history with the project.
- Mr. Powell reviewed the current project status and latest developments.
- Finally, a presentation of environmental issues was given by Mr. Méndez. The discussion included basic components of an EIS, the Supplemental EIS for this project, and the purpose of the socioeconomic trip.

Following the presentation, there was a question and answer session, in which twenty to thirty questions were raised. The audience was comprised of approximately 150 participants, including 70-80 teenage students. Following is a summary of the principal questions and concerns expressed:

- Question: Is it possible for the project to finance a gas pipeline to Pailón to provide gas for all the residents of the town?

*Answer: It was explained that the project was not considering a connection to any of the towns along the route at this time. Although this is technically possible, it would have to be economically justified. The purpose of the project is to sell gas to Brazil.*

- Concern: The economic benefit of the project for Pailón did not appear to be clearly understood. One individual expressed the feeling that to have the economic boom only during the construction period would not be sufficient because the construction period was too short. He felt that the project should leave something else to provide economic benefit for Pailón.

*Answer: It was shared with the audience that taxes generated by the project would be distributed to the municipalities in accordance with current Bolivian regulations.*

- Concern: One individual expressed a concern about hunting, not only during the construction period, but also after construction. There was a concern that the right-of-way might be used as a path for people to gain access into areas which are now inaccessible.

*Answer: It was explained that hunting by construction personnel will be strictly forbidden, and anyone who violates this rule will be terminated. Following construction, barriers to prevent vehicle access will be constructed to discourage access to the new right-of-way. Also, the proposed Right-of-way was partially cleared for surveying some time ago, and there is little evidence of colonization due to the previous clearing.*

- Question: What is the possibility of having an accident due to a gas leak in a populated area, which might kill people?

*Answer: Safety records in the United States indicate that gas pipelines are the safest means of transporting energy, and this should not be a concern. In addition, the pipeline route does not include heavily populated areas.*

- Question: Would it be possible for any of the infrastructure built for the pipeline to be left for use by the people of Pailón, such as a school, meeting place or library?

*Answer: Some infrastructure will be required for construction of the pipeline, and where practical and economically reasonable, some of these facilities will remain.*

- Question: What will be the income generated by the project in dollars per day or dollars per year? How many years will it take the project to pay for the cost of construction? What is the cost of the project and the interest of each of the participating companies? They also wanted to know if Bolivia would pay for the pipeline cost in Brazil and how much Bolivia would receive from the total profits of the project.

*Answer: Revenue from the sale of gas is expected to be \$US250-300 million per day, based on an initial demand of 8 million cubic meters per day. The time required to pay for the cost of construction will depend upon the term of financing. The cost of the*



*Bolivian sector of the project is approximately \$US450 million. Participation of YPFB/Enron in the Bolivian transportation company is 85%, and Petrobras/BTB 15%. Pipeline costs in Brazil will be shared by all partners according to the terms of the agreements in Brazil.*

- Question: They asked about the schedule for construction and the most likely time to start construction.

*Answer: It is anticipated that the earliest start date for construction is July, 1997.*

- Question: They asked about the public participation program and expressed more interest in the infrastructure of the project remaining for the benefit of the local community.

*Answer: It was explained to them that there were three different levels of economic benefit from the project, 1) there would be employment opportunities and other direct benefits during construction, 2) they would realize benefits indirectly through the distribution of taxes from the central government, based upon the number of people in the municipality, and 3) some infrastructure required for the pipeline construction would remain for the people. They understood the tax distribution process, but claimed that they would get that money anyway even if the project were following another alignment. They stressed that they wanted to see more direct benefits from the project through enhancements to the infrastructure that could be used by the town.*

- Question: A representative from the teachers association commented that they are building a new room which will be used for teachers' meetings, training or a library. They wanted either the project or the companies involved in the project to contribute to some of the construction costs.

*Answer: This request will be taken under advisement.*

#### 8.4.2 San José de Chiquitos

Attendees to the meeting in San Jose de Chiquitos on May 20, 1996 included:

Jim Alexander - Enron  
Kay Beasley - BTB/Tenneco  
Juan Tavolara - YPFB  
Carlos Méndez - Dames & Moore  
Laine Powell - Enron  
Javier Olmedo - Dames & Moore

- The meeting opened with an introduction given by the Mayor, Mr. Gerardo Pereira Flores. The group was also welcomed by the Subprefecto of the Chiquitos Province, Mr. Hugo Rivero Antelo. Presidenta Concejo Municipal, Ms. Jenny L. de Ferrante, was also part of the official delegation. The meeting was attended by approximately 100 people, including 35 students.
- Mr. Tavolara made a presentation about the proposed gas pipeline project and its history, Mr. Powell discussed the financial aspects of the project and latest developments, and Mr. Mendez spoke about the Supplemental EIS.

Following the presentation, a question and answer period was opened. Most of the questions focused on three areas: water supply, electrical energy, and construction of a roadway between Santa Cruz and Puerto Suarez. Questions, concerns and answer are summarized below:

- Question: It was indicated that San José de Chiquitos has severe water supply problems. In this area up to 30,000 liters per hour can be produced from a 100-meter deep well. The question was if the project could provide wells for water supply.

*Answer: The project did not include solutions for local problems; however, the project would have requirements such as water, and one of the purposes of these meetings was to ascertain local needs to be able to assist local communities whenever possible.*

- Concern: One gentleman related a previous experience with YPFB wherein the YPFB plant in San José had a water connection from the city water supply which had taken a large volume of water from the local population during construction. He felt YPFB should have an obligation now to repay the negative impact of this water usage.

*Answer: During construction, the project would see if assistance could be provided.*

- Question: The electrical generators in the town are insufficient for adequate generation of electricity. It was asked if the project could supply electricity for the town of San José.

*Answer: Again, the response was that we were making note of the town's needs and would attempt to fulfill needs of the project and the community where feasible.*

- Question: It was asked if a pipeline connection could be made to bring gas to San José which could be used for the generation of cheaper electrical energy.

*Answer: It was indicated that technically this was possible, but it would have to be economically feasible and that would depend upon the market. It was also explained that the project was not considering a connection to any of the towns along the route at this time, but we were taking note of the needs to evaluate the possible assistance. However, the purpose of the project is to sell gas to Brazil, and this is a national project, not a local project designed to resolve local problems.*

- Question: Will the subsidies currently given by YPFB for diesel used for generation of electricity by electrical cooperatives continue? If after the capitalization of YPFB this will not be the case, the cost of a kilowatt hour would increase from approximately \$1.00 per kilowatt to \$2.00 per kilowatt.

*Answer: Mr. Tavolara indicated that this did not depend on the project, but rather the government, and that he would attempt to provide this information to the local authorities.*

- One individual said he felt the project should study the possibility of not only supplying gas to the town, but also installing an electric generator to supply the mines located near San José and Roboré.
- Another gentleman spoke about how thirty years ago the government labeled international companies such as Enron as a huge black 'octopus' that would take resources from countries and give nothing in return. In the past few years things have changed, governments are being sold to international corporations, and this was a good opportunity for Enron to demonstrate that they were not the big octopus of the past - that they had a local interest and responsibility to support the development of the local towns they would impact in the project. He felt Enron should consider the possibility of using its influence with the authorities in order to: 1) secure a gas powered electric generator for San José, 2) convince the government to drill two to three wells for water supply and 3) use their connections with the government to send a message that construction of a roadway from Santa Cruz to Puerto Suarez was greatly needed by the towns which would be impacted by the project.
- Concern: The supervisor of teachers in the area said that all the information given in the presentation was of a commercial type, simply public relations, and that he was disappointed that we did not have any solutions for the town's problems. He felt we should have come with actual proposals that would have real solutions for local problems

*Answer: It was explained that the purpose of the presentation was to inform the public about the project and to learn about the concerns of the local communities.*

- Concern: One man stated that local authorities don't always use the resources such as taxes in the best way for the communities. He wondered if it was possible for the project to make a deal with the government to build a thermoelectric plant in San José in exchange for taxes so the government doesn't have to put their hands on taxes.

*Answer: It would not be possible for the project to change the laws of the country which determine the distribution of taxes to local communities through appropriate local authorities. Such a proposal could be considered intervention into local politics.*

- **Concern:** One individual expressed concern that the improvements to be made to access roads which will be used for the project would be only temporary cosmetic improvements to provide for use during construction and that the roads would be a mess following construction. He felt that the project should make more substantial improvements so that the roads would be in better condition after the project is completed so the roads could be used for other purposes such as ecotourism of the Gran Chaco Park.
- **Question:** The last question was whether the right-of-way could be left for use as a roadway following construction to connect Pailón to Quijarro so that the local communities could use the roadway for development of the area.

*Answer: This would not be possible due to environmental concerns. The area is very important from an ecological point of view and as such no roadway could be left. To do so would encourage colonization of the area.*

### 8.4.3 Roboré

The public presentation was held in Colegio Marista (Marista School) on May 21, 1996 and was attended by approximately 200 people, including 115 students. Attendees to the meeting also included:

Jim Alexander - Enron

Kay Beasley - BTB/Tenneco

Carlos Méndez - Dames & Moore

Juan Tavolara - YPFB

Laine Powell - Enron

Javier Olmedo - Dames & Moore

Marie Lissette Canavesi Rimbaud - Dames & Moore

Mr. Tavolara gave the project description, Mr. Powell discussed the financial situation and recent developments, and Mr. Méndez elaborated upon the Environmental Impact Study, followed by a question and answer period.

The questions, concerns and answers were as follows:

**Question:** Roboré has a severe electrical supply problem. They have a diesel generator which is very expensive to operate. They asked if the project could provide gas to Roboré to generate electricity in Roboré.

*Answer: Technically, this was possible, but financial and economic studies would be required to evaluate the feasibility of such a project.*

**Question:** Many years ago the project sponsor, YPF, said that generators were going to be installed close to the gas pipeline in order to reduce the cost of transporting gas to Roboré. What was the possibility that the project could build and install a gas power generator close to the pipe then the electricity would be taken to Roboré and San José or other towns by cable? They understood that the cost of this project was about \$1 million.

*Answer: This option would have to be studied, along with other options such as transporting gas to one of the towns and used for a generator, but that this is not part of the current project and would have to be sponsored by other parties.*

One gentleman asked if the project sponsors could pay for a feasibility study to evaluate the possibility of bringing gas to Roboré? Another gentleman interrupted and stated that they did not want a study, that they wanted electricity.

**Question:** What was the possibility of changing the route of the project so that the gas pipeline could go through the towns along the railroad which would allow an easy access to each town of gas for the purpose of generating electricity?

*Answer: It was explained that the alignment was chosen due to environmental and economic reasons, and that running the gas pipeline near the towns would cost several million dollars more.*

Comment: The project should include conditions which would allow the possibility of getting a permanent solution to the energy problem. The population of Roboré is decreasing, and they are desperate to obtain cheap energy for the region so that people could stay and come to Roboré to develop the area. If at this time there is no possibility of generating energy or taking gas to Roboré, at least there should be conditions in the contract that would allow Roboré to get the required connection once it is economically feasible.

Question: What is the current status of the project?

*Answer: The answer was a brief description of where we are with the technical, financial, and economic studies.*

Question: There was a request by another gentleman who suggested the Subprefectura of Chiquitos would be asked to participate in a series of meetings with the rural electricity cooperative (CRE) in Santa Cruz with the project sponsors to evaluate the possibility of getting electricity to these towns. He also asked how the project could contribute to gas supply for generators located along the pipeline.

*Answer: The response was that it would be possible for the project sponsors to attend such a meeting, and the Subprefecture indicated he would contact Mr. Tavolara in Santa Cruz to set up some meetings with the CRE people to see what their plans were to provide electricity in the region and what plans they had to install gas generators, specifically in relation to the needs and to the markets created by the energy triangle which is define as Roboré, San José and the mining development to the north of San José.*

Comment: A comment was made that the project should conduct a feasibility study to set up and operate a power plant that would be designed for supplying electricity to all communities that the project would affect.

*Answer: The project sponsors, because of the new Hydrocarbon Law, could not participate in anything except transportation once they have associated with YPFB in the Gas Pipeline Project. For this reason they will be unable to start any generating facilities.*

Concern: One individual stated that Roboré has always been left aside. The roadway hasn't been built, the pipeline is not going through Roboré, it was very important for them that the project sponsors consider Roboré in their plans during the design. Again, they wanted to reiterate how important electricity was, how important it was that the Subprefecto be responsible for all contacts with the government and with CRE to solve the electricity problem in the area with the contribution of the project sponsors.

*Answer: The Subprefecto accepted this request, and he indicated that he would contact YPFB representatives through Mr. Tavolara in Santa Cruz to set up the meetings and see what could be done for the electricity problem of Roboré.*

#### 8.4.4 El Carmen

Attendees to the meeting in El Carmen on May 22, 1996 included:

Jim Alexander - Enron

Kay Beasley - BTB/Tenneco

Carlos Méndez - Dames & Moore

Juan Tavolara - YPFB

Javier Olmedo - Dames & Moore

Marie Lissette Canavesi Rimbaud - Dames & Moore

An introduction was given by the Alcaldesa (The Mayor of the town), followed by the presentation by the Project Team. The meeting was attended by approximately 175 people.



Questions, concerns and answers following the presentation are summarized as follows:

Question: El Carmen has been growing in the past few years and is in urgent need of development. Would El Carmen have access to a special valve to get a gas connection to supply gas to the town.

*Answer: Technically this would be possible at any time during operation of the project, but it would be more dictated by market conditions. The cost of the pipeline and any additional infrastructure is not within the scope of the transmission line project and would have to be funded through other sources. The project does not include a valve as presently designed.*

Question: Why is the project using the railroad when they could use a roadway in order to help the development and improvement of the existing roadway?

*Answer: Project sponsors indicated the railway was a more economic means of transportation, but that the final decision would be made by the turnkey contractor.*

Question: One individual understood that the project is going to build some roadways. Is it going to be possible for the local population to have access to the new roadways?

*Answer: No new roadways were anticipated to be built. Some existing roadways were going to be improved and would be turned over to the public for their use. The right-of-way was going to include a path along the alignment which was not going to be used for transportation. It would be used only for maintenance and operation of the pipeline.*

Question: The local doctor stated that they recognize that the project would have a requirement for use of local labor, and they were happy to hear about that. But also they understood that there was going to be infrastructure built in different towns. He wanted to know if medical centers were going to be set up in each one of these towns or if major medical problems would be moved to other cities. He asked if it was possible that localizing the medical services in the towns the project could improve some of the infrastructure.

*Answer: Project sponsor were in the process of deciding if the project would require local medical services, and most likely there would be some locations along the pipeline where infrastructure would be improved.*

Question: The doctor indicated that El Carmen had good medical infrastructure, but had limited financial resources. He asked if it were possible to include in the terms of reference for the project a requirement for the contractor to improve supplies and infrastructure related services like a pharmacy, medical laboratory, x-ray services, and surgery room which they really need in the area. He also indicated that they only have one doctor and they would like for the project to increase that number so that El Carmen could be used as a permanent medical facility for the project.

*Answer: The project would include some improvement in infrastructure, and that it was very important to know which towns had good infrastructure. In some cases, like El Carmen, the project might consider the possibility of improving services and improving resources as a way to be able to use the existing infrastructure*

Question: El Carmen hasn't had any electricity service for several years. The distribution network had been built, and they have two existing generators, but they are very old and out of order. They wanted to know if the project could provide electricity to the town.

*Answer: The project would include the installation of electrical power generators in some areas. They would be diesel generators, and they would be located at different places along the alignment. As part of the project we are trying to evaluate which areas are going to be the best areas for these generators to be located, not only from the project point of view but also for the local town needs.*

Question: Will the project be able to use local labor based in El Carmen?

*Answer: The project would give preference to local labor in each one of the towns, including El Carmen.*

Question: They indicated that El Carmen has only one water well which is about 100 meters deep and has a capacity of 10,000 liters per hour. However, the pipeline distribution network is over 30 years old and is in very bad condition. Can the project help improve the water distribution and water supply services for the town?

*Answer: The project would drill some wells, and again just as in the case of the generators, in the design phase of the project the sponsors would determine the best locations for the wells to be drilled to meet the project needs and meet some needs of the towns that would be located close to the right-of-way.*

Question: What is the status of the YPFB exploration well drilled in Santa Ana?

*Answer: Mr. Tavolara did not know the current status, but would find out in Santa Cruz and send a message through the local Mayor.*

Question: Could the project build a water well to improve the water supply capacity of El Carmen?

*Answer: The response was the same as above.*

Question: Will the project pay for the damage to crops along the alignment that were going to be damaged?

*Answer: Yes, the project included compensation for crops that would be affected negatively along the pipeline. This is part of the Bolivian legislation, and it was going to be respected.*

#### **8.4.5 Puerto Suárez**

The meeting in Puerto Suarez on May 23, 1996 was attended by approximately 150 people, including 100 students. Attendees to the meeting also included:

Jim Alexander - Enron  
Kay Beasley - BTB/Tenneco  
Carlos Méndez - Dames & Moore  
Enrique Escobar Ayoroa - YPFB  
Juan Tavolara - YPFB  
Javier Olmedo - Dames & Moore  
Marie Lissette Canavesi Rimbaud - Dames & Moore

Following the presentation of the project, the floor was opened to questions, concerns, and answers which were as follows:

- Question: What would be use of the right-of-way upon completion of construction; specifically, would it be used as a roadway between the Brazilian border and Santa Cruz?

*Answer: It would not be used for this purpose due to ecological aspects, this is part of the sustainable development the government is pursuing, that due to the Gran Chaco Park no roadways would be left permanently in the area except the existing roadways, which would be improved.*

- Question: How many personnel would be required for each of the compressor stations?

*Answer: Personnel requirements would be minimal - perhaps 3-5 people because most of the controlling units would be connected to Santa Cruz, and all the control would be carried out in this city.*

- Question: Would it be possible for the project to improve the existing roadway for transportation of the pipe by truck, rather than use the railway?

*Answer: This would not be possible due to economic reasons. The railway offered the least cost transportation alternative. It was added that this would be left up to the turnkey contractor, but use of the roadway for transportation of supplies and materials did not appear to be feasible.*

- Question: What kind of infrastructure would be built in Puerto Suarez?

*Answer: Only the metering station which will be located on the border. The station would measure the volumes of gas leaving Bolivia, since Bolivia would charge Brazil for the volumes measured at the border.*

- Question: They were aware that the original scope of the project included a development program for the Puerto Suarez area. The question was if current project conditions include a gas connection to the Mutun mining development.

*Answer: Setting up a gas network along the pipeline was technically possible. Whenever the Mutun mining development effort could demonstrate that conditions were ready for purchasing gas from the pipeline, it would be possible to do so at that time.*

- Question: Does the project include construction of an electric power generator in Puerto Suarez?

*Answer: It was included in the previous program, but it is no longer part of the project. The project sponsors could no longer build a power generation facility as part of the project due to the new Hydrocarbon Law, which will not allow them to generate electricity when they are in the transportation business.*

- Question: Does YPFB need to be capitalized in order to execute the gas pipeline project?

*Answer: The reason for the capitalization of YPFB was to get new investors into the gas exploitation business which would expand the gas supply for the gas pipeline project. The more companies invested in exploration, the more gas would be available to be exported to Brazil.*

- Question: What is the reason the project does not follow the railroad alignment and the main towns located between Santa Cruz and Puerto Suarez?

*Answer: The reason was based on both environmental and economic reasons - it is much more expensive to route the pipeline through the towns and parallel to the railroad system.*

- Question: Puerto Suarez does not have good electrical service. They were aware that the 1972 treaty with Brazil considered extending the electrical network along the Chiquitania. The question was 1) does the project include construction of a thermoelectric plant to be located in Puerto Suarez, and 2) if the project could include installation of a gas plant to be able to distribute and sell liquefied petroleum gas (LPG) to be sold?

*Answer: The project did not include the construction of a generating facility because the new Hydrocarbon Law prohibits construction of a power generator by a company in the transportation business. The project could not include LPG distribution because they were two different types of gas. Natural gas is methane and cannot be used to produce LPG, which is comprised of butanes and propanes.*

- Question: Why could the project not include construction of a thermoelectric plant in Puerto Suarez?

*Answer: Again, the response was that this was due to the new Hydrocarbon Law.*

- Question: What kind of economic benefit would each one of the towns have in relation to labor opportunities with the project and what kind of instrument would the project have to ensure that the contractor gives preference to local people?

*Answer: Local labor would be used and local communities would be given preference. The Environmental Impact Assessment would include a socioeconomic chapter where recommendations would be made to give preference to hiring local labor.*

- Question: The Santa Ana wells YPFB drilled some time ago prompted the following question. Do YPFB representatives believe that the area in the German Bush territory includes important gas reserves that could be used in the future?

*Answer: We didn't have any experts in the gas exploration fields, the project team understood that this well was not successful, but were going to check to determine the correct status. An example was given that several years ago in the Cochabamba area the first exploitation efforts failed, but in recent years significant reserves of gas have been found and now Cochabamba is a very active gas supply area.*

#### **8.4.6 Puerto Quijarro**

Attendees of the meeting in Puerto Quijarro on May 23, 1996 included:

Attendees:

Jim Alexander - Enron

Kay Beasley - BTB/Tenneco

Carlos Méndez - Dames & Moore

Enrique Escobar Ayoroa - YPFB

Juan Tavalara - YPFB

Javier Olmedo - Dames & Moore

Marie Lissette Canavesi Rimbaud - Dames & Moore

The meeting was attended by approximately 60 people, including 25 students. Following the presentation by the Project Team, there was a question and answer period in which the following questions were asked by the local citizens:

- Question: Are the Bolivian gas reserves guaranteed for the project, and would it be possible, based upon current knowledge of these reserves, to sell gas to other countries in addition to Brazil, like Uruguay and Paraguay?

*Answer: Yes, there were enough reserves in Bolivia to comply with the contract with Brazil and it was expected that additional reserves were going to be found in the next few years that only less than 50% of the country has been explored and therefore it was expected that additional gas reserves would be found. With respect to extending the*

*network to sell gas to other countries, the answer was that it is possible, but at this time the project only considered the sale of gas to Brazil.*

- Question: What is the current status of the transportation contract for the pipeline into Bolivia?

*Answer: The contract was not finalized yet, that the project sponsors were working on the terms of reference and the financial terms of the project.*

- Question: What is the current status of the thermoelectric project to be located in Puerto Suarez?

*Answer: This time the project did not include a thermoelectric plant for Puerto Suarez and that the project sponsors could not build any generating facility because of the new Hydrocarbon Law.*

- Question: What will be the cost of infrastructure which could be transferred to the local utilities after the project construction is complete? For example, wells and electrical generators which could be transferred to towns like El Carmen - would these be given as a gift or would there be a cost associated with the transfer?

*Answer: This time we are in the process of evaluating the possibilities to determine the best way to transfer infrastructure to the local towns.*

- Question: Will the existing path be used for the right-of-way or will a new path be opened in the forest for the pipeline?

*Answer: The existing path would be used for the pipeline.*

- Question: Will the project consider construction of a port facility in Puerto Quijarro for unloading pipe? If so, are there any provisions for leaving improvements in port construction facilities to benefit the local community?



*Answer: There were no plans to build a new facility in Puerto Quijarro. If possible, existing facilities would be used. If required these facilities may need improvement, but this depends more on the transportation contract bidding process.*

- Question: Is there any clause that would be included in the terms of reference to specify the requirement for hiring local workers?

*Answer: No, the terms of reference did not include any such clause. However, the Environmental Impact Assessment would make a recommendation to use and give preference to local labor.*

- Question: Has the project taken in account some measures to improve existing roadways from Puerto Suarez to El Carmen, taking into account that the existing roadway cannot be used during approximately six months of the year?

*Answer: Any roadway that needed to be improved for the purpose of transporting pipe by truck would be improved, and the local towns would benefit from this.*

- Question: What will be the economic benefit to the local towns with respect to the construction of the 557 km in the Bolivian territory?

*Answer: In addition to the use of local labor, local enterprises will be asked to present proposals for various types of work that was going to be bid.*

- Question: How will the project take into account the inspection of construction work?

*Answer: Most likely an independent company would be hired for the quality assurance/quality control of the project.*

- Question: Is there an Environmental Impact Assessment for the compressor stations, and is there any provision to locate a compressor station close to or in the vicinity of Puerto Suárez and Puerto Quijarro?

*Answer: The EIS included construction of four compressor stations in the Bolivian territory. However, at this time only one would be constructed. The only station near Puerto Suárez or Puerto Quijarro will be located in Yacuses.*

- Question: What kind of infrastructure will be built on the Bolivia/Brazil border to measure gas volumes?

*Answer: There will be a metering station that will require a small parcel of land and minor infrastructure.*

- Question: Will the terms of reference define the beginning of the construction period and when will the terms of reference for the project be ready for distribution to the public?

*Answer: The terms of reference are not yet complete. The project sponsors are working on them, particularly with regard to the pipeline supply and transportation services.*

- Question: Will it be possible to improve and use the existing roadway between Puerto Suarez and El Carmen to transport pipe to the right-of-way?

*Answer: Any roadway that needed to be improved for transportation of materials would be improved if necessary.*

- Question: How much time will it take to get rid of all the gas in Bolivia if we sell 16 million cubic meters per day?

*Answer: Initial delivery volumes are estimated to be 8 million cubic meters per day, escalating to 16. There is sufficient gas to comply with the contract period of 25 years; however, with the new capitalization law, it is expected that additional gas reserves will be found in the country to provide gas for many more years.*

**TABLE 8.1**  
**SURVEY RESULTS**  
**FROM**  
**PUBLIC CONSULTATION MEETINGS**

QUESTION	OPTIONS	PAILON n* = 42	SAN JOSE n* = 51	ROBORE n* = 59	EL CARMEN n* = 49	PUERTO SUAREZ n* = 78	CABI n* = 22
1 What do you like most about your city?	a. Weather	20	21	24	25	13	15
	b. Landscape	13	25	40	20	34	14
	c. Life style	20	36	17	22	35	10
	d. People	12	16	21	15	9	10
	e. Others	0	0	0	0	0	0
2 Why do you think most people live in your city?	a. Economic factor	36	25	14	21	63	18
	b. Family factor	14	29	30	26	10	13
	c. Social factor	10	10	11	9	7	8
	d. Traditional factor	10	19	19	14	9	8
	e. Ethnic factor	3	6	4	8	5	2
	f. Political situation	7	4	7	1	7	3
	g. Others	6	1	0	0	0	1
3 What problems does your community deal with?	a. Crime	8	2	2	1	12	7
	b. Housing	19	25	10	14	23	14
	c. Education	22	26	12	21	53	15
	d. Health	25	31	21	31	48	17
	e. Poverty	23	27	29	31	27	18
	f. Land tenure	12	6	3	11	9	19
	g. Bounderies between communities	0	2	3	7	4	7
	h. Turmoils	0	0	1	3	0	2
	i. Lack of road infrastructure	17	42	49	40	66	14
	j. Lack of other type of infrastructure	13	17	12	15	19	10
	k. Unemployment	17	33	35	35	29	14
	l. Others	1	18	9	6	6	2

\* Number of surveys carried out at each location

Each number reported in this table represents the number of individuals that included a subject item as one of the several items included in one single answer.

4 What do you think are the main causes of your community problems?

SOCIO-ECONOMIC UNIT	OPINIONS
<p><b>PAILON</b></p>	<p>Lack of Governmental and Municipal Attention                      Lack of medical infrastructure and professional doctors                      Lack of infrastructure for education                      Lack of roads                      Lack of support and employment generation by companies                      Large migration of people to other parts of the country                      Economical problems                      Poor condition of streets                      Lack of credit lines for housing                      Lack of sport and recreational infrastructure                      Lack of housing infrastructure and low salaries                      Lack of rational distribution of the land, oligarquial system serving foreign capitals                      Road abandonment and authorities lack of interest                      Duplicity on land property titles                      Lack of infrastructure for higher education, which causes young people to travel overseas for specialization                      Lack of a two-way road on the Rfo Grande bridge</p>
<p><b>SAN JOSE</b></p>	<p>Lack of incentive policies and effective support                      Lack of job sources                      Lack of maintenance on secondary roads                      Lack of specialists in medical centers                      Lack of local companies                      Lack of energy at reasonable prices                      Lack of potable water                      Lack of technology                      Lack of interest of authorities                      Lack of education                      Lack of economical resources                      Poor organization and management by local Authorities                      Excess bureocracy in central government                      Lack of support from central government                      Lack of schools                      Lack of medical equipment</p>

4 'What do you think are the main causes of your community problems?	
SOCIO-ECONOMIC UNIT	OPINIONS
<b>ROBORE</b>	<p>Lack of heavy machinery and effective roads policy (National Roadway Service)</p> <p>Lack of resources and geographic isolation</p> <p>Lack of local companies, education and transport</p> <p>Low economic level</p> <p>High cost of electricity</p> <p>Lack of governmental support</p> <p>Lack of a long-term plans with defined goals</p> <p>Lack of local projects that generate jobs</p> <p>Lack of organization, there are no exports for development and people are not taken into account</p> <p>Lack of banks with incentive credits</p> <p>There are no productive zones, lack of support to cattle raising and agricultural activities</p> <p>City is isolated</p> <p>Lack of medicines</p> <p>Lack of unity among locals and Menonites</p> <p>Lack of solidarity and team work</p> <p>Lack of coordination among authorities</p> <p>Lack of education and organization</p>
<b>EL CARMEN</b>	<p>Authorities are negligent towards the town</p> <p>Lack of roads to Puerto Suárez and Santa Cruz</p> <p>There is no medical infrastructure</p> <p>Economic problems and disunited policies</p> <p>Lack of technical assistance to agriculture and cattle raising activities</p> <p>Lack of doctors and dentists</p> <p>There is no higher education</p> <p>Lack of job sources, and lazyness as the most important reason</p> <p>Lack of funding to solve local problems</p> <p>Scarce economical resources</p>

4 'What do you think are the main causes of your community problems?	
SOCIO-ECONOMIC UNIT	OPINIONS
<b>PUERTO SUAREZ</b>	<p>Lack of attention to progress by local Authorities</p> <p>Lack of citizens participation</p> <p>Lack of liquidity on the economy</p> <p>Lack of local investment and projects</p> <p>No basic sanitary infrastructure</p> <p>The idea of a local development center must be put to practice</p> <p>Town's lack of interest and people with few ambitions, they prefer easy things rather than working on a daily basis</p> <p>Incipient agriculture and cattle raising activities</p> <p>There is no production, just commercialization</p> <p>There is no governmental support</p> <p>Most of first needed items are brought from Santa Cruz and/or Corumbá</p> <p>Lack of capital towards the production</p> <p>There is a lack of mechanization and technical assistance</p> <p>Lack of interest towards agricultural work</p> <p>Production is for family consumption only</p>
<b>CABI</b>	<p>Poor management of economic resources</p> <p>Lack of higher education</p> <p>Lack of medicines and medical care</p> <p>Lack of transportation</p> <p>Lack of electric power</p> <p>Lack of job sources</p> <p>Lack of infrastructure for education</p> <p>Lack of trained leaders</p> <p>Government does not support the development of local communities</p> <p>Lack of social care</p>

QUESTION	OPTIONS	PAILON n* = 42	SAN JOSE n* = 51	ROBORE n* = 59	EL CARMEN n* = 49	PUERTO SUAREZ n* = 78	CABI n* = 22
5 Describe the agricultural activity?	a. Intensive	22	10	7	6	10	12
	b. Extensive	13	10	14	11	7	6
	c. Mechanized	25	9	4	0	2	2
	d. Monoculture	1	21	24	17	18	8
	e. Diversified	13	19	13	10	19	4
	f. Others	0	0	0	0	0	0
6 Describe the livestock raising activity?	a. Intensive	14	18	8	12	7	7
	b. Extensive	8	13	15	6	9	5
	c. With cultivated pasture	25	29	13	9	20	3
	d. With natural pasture	12	40	45	36	53	18
7 What kind of livestock do you have in your community?	a. Specie						
	Bovine	31	39	45	31	46	16
	Sheep	0	3	0	0	1	3
	Equine	11	25	19	17	15	13
	Hog	8	17	10	13	21	11
	Others	0	0	0	0	0	0
	b. Breed						
	Native	26	34	34	29	35	16
	Other	7	8	4	1	3	5
	8 What sort of domestic crops and animals are there?	Poultry breeding	34	37	35	31	43
Bovine		6	5	3	0	22	6
Equine		2	2	0	0	11	4
Hog		20	23	19	16	36	9
Others		19	16	17	13	25	6
None		5	6	5	2	2	0

QUESTION	OPTIONS	PAILON n* = 42	SAN JOSE n* = 51	ROBORE n* = 59	EL CARMEN n* = 49	PUERTO SUAREZ n* = 78	CABI n* = 22
9 What products provide a surplus?	Soy	29	22	0	0	1	1
	Corn	17	11	5	4	0	7
	Cheese	0	14	0	0	0	0
	Weed	13	1	0	0	0	0
	Sorghum	8	1	0	0	0	0
	Sunflower	15	0	0	0	0	0
	Rice	1	2	0	3	0	3
	Cotton	15	1	0	0	0	0
	Cattle meat	1	9	10	5	4	0
Others	0	20	16	36	14	14	
10 How are the surplus commercialized ?	Intermediary	24	17	9	12	5	9
	Direct Sale	6	2	7	4	10	4
	Exchange	0	3	4	8	4	8
	Other	0	0	0	0	0	0
11 Is the production enough for the city consumption?	Yes	10	18	13	11	12	0
	No	24	29	35	29	59	5
12 Where are the existing surplus commercialized?		Brazil Argentina Local Market Santa Cruz Intermediaries Other cities Communities	Local market Santa Cruz Communities	Local market Brazil Communities	Santa Cruz Puerto Suarez Puerto Quijarro	Brazil	



**CHAPTER 9.0**  
**CONCLUSIONS AND RECOMMENDATIONS**

**TABLE OF CONTENTS**

9.1	INTRODUCTION .....	9 - 1
9.2	CONCLUSIONS .....	9 - 1
9.3	RECOMMENDATIONS .....	9 - 3

## 9.0 CONCLUSIONS AND RECOMMENDATIONS

### 9.1 INTRODUCTION

The conclusions and recommendations presented in this chapter are based on the results of the Environmental Impact Study (EIS) for the Bolivia to Brazil Gas Pipeline Project (Bolivian Portion).

### 9.2 CONCLUSIONS

The following conclusions take into account the existing environmental legislation in Bolivia, the new Hydrocarbon Law, the international environmental guidelines, the technical characteristics of the project, the existing environmental and socioeconomic conditions, the anticipated potential impacts associated with the project, and the proposed Environmental Management Plan as presented in this report.

- The area of influence of the project, defined here as the study area, includes three main ecological units: the mostly-flat alluvial plains of the Llanura Chaqueña, the marshes of the Bañados de Izozog and Otuquis, and the hills and foothills of the Serranías Chiquitanas.
- Through much of the study area, land use is sparse, partly due to limited land use capability associated with poor soils, low precipitation, and a lack of readily available surface and groundwater. Native, undisturbed vegetation is prevalent throughout the study area.
- The population in the study area is small, and largely concentrated in five population centers located along the railroad: Pailón, San José de Chiquitos, Roboré, El Carmen, and Puerto Suárez/Puerto Quijarro. Additionally, in the vicinity of the study area the Capitanía del Alto y Bajo Izozog (CABI) is the umbrella organization for 22 Izozeño Indigenous groups settled along the Parapetí River.

- The Gran Chaco National Park is considered the most environmentally sensitive area within the study area, due to its protected status, large biological resources, indigenous populations, and biogeographic status. The pipeline right-of-way will traverse the Integrated Management Area of the park, which will not represent a conflict with allowable land uses within this area.
- Throughout most of the study area, the physical and biological environment seems to be resilient to the type and magnitude of impacts anticipated to occur because of the project: the primary direct impact is the widening of an already cleared swath 5-10 wide. The western part of the study area is criss-crossed with 3 to 30 year old cut lines from seismic surveys with no negative secondary effects observed during this study.
- The proposed pipeline alignment was selected because it traverses relatively homogeneous terrain and avoids areas of slope instability and populated areas. This route was determined to balance best the overall impacts to the human, biological, and physical environment while achieving its overall purpose, which is to transport natural gas from production fields in Bolibia to the markets in southern Brazil through an environmentally acceptable and economically viable transportation project.
- The logistics assessment had identified the locality of Naranjos as a storage area with an access road connection to the pipeline right-of-way. The area reconnaissance revealed the existence of a nearly pristine mesic forest between Naranjos and the right-of-way. Evidence of incipient human encroachment into this area was observed along a narrow access road built three years ago. It was decided that this location and access road would not be used to prevent additional direct impacts to the forest and to discourage further encroachment along the access road.
- As originally proposed, the route was designed to traverse the Cañón de la Victoria across its narrowest point, thus minimizing the length of the direct impact to the wetland. The Cañón de la Victoria is a hydrologic and biological connection between the wetland systems of the Bañados de Otuquis, in Bolivia, and the Pantanal, in Brazil. The review of the area suggested that the pipeline crossing at the narrowest point would affect a nearly

pristine marsh and may affect the hydrologic connection between the systems. A route modification was proposed to make the route parallel to the existing road/railroad corridor, where the pipeline would traverse a longer section of the floodplain, but along an already disturbed corridor. Thus, the new route will result in minimal additional impacts to this regional wetland system.

- The main anticipated negative impacts of the project in its area of influence will be: a) the removal of vegetation and wildlife habitat along the right-of-way, b) the increase in the potential for erosion, sedimentation, and hydrology disruption due to project construction activities, c) the potential for increased hunting pressure on species of special concern, d) the potential for promoting colonization of undisturbed areas, and e) the potential disruption of the hydrologic patterns in the rivers and Bañados.
- The primary anticipated positive impacts of the project will be: a) an increase in revenues for Bolivia from the sale of gas to Brazil, b) a redistribution of those revenues back into the area of influence of the project, c) a temporary increase in employment within the study area, d) an improvement in the road infrastructure, which is needed to execute the project, e) an increase in the demand for goods and services in the study area, which may promote wholesale and retail commerce in the area, and f) a contribution to an Endowment Fund to supplement existing funds allocated for the management of the Gran Chaco National Park and the protected park areas in the Department of Santa Cruz.

### 9.3 RECOMMENDATIONS

To ensure that the project is executed within the environmental and socioeconomic limits established by the regulatory framework and outlined in the Environmental Management Plan, the following recommendations are offered:

- Final design of the project should refine procedures, and design parameters to fully respond to the environmental concerns identified in this Environmental Impact Study.

- Implementation of the Environmental Management Plan presented in the EIS is required to provide appropriate mitigation of unavoidable impacts and lower the significance of negative impacts to acceptable levels under the current Bolivian regulatory framework and international standards.
- The project sponsors should continue to track the public's perception regarding the project in order to evaluate new or changed concerns as they relate to the final design and execution of the project.

## 10.0 BIBLIOGRAPHY

- American Gas Association. 1990. An Analysis of Reportable Incidents For Natural Gas Transmission And Gathering Lines, June 1984 Through 1989. NG-18. Report No. 196.
- American Gas Association. 1985. An Analysis of Reportable Incidents for Natural Gas Transmission and Gathering Lines, 1970 Through 1984. Ng-18 Report No. 158.
- Brown, K. Jr. 1986. Zoogeografía da Região do Pantanal Mato-Grossense. Anais de 1o. Símposio sobre Recursos Naturais e Sócio-Económicos do Pantanal. Ed. Ministerio da Agricultura - MA; Empresa Brasileira de Pesquisa Agropecuária - EMBRAPA. Corumbá - Brasil pp 137 - 178.
- Cabrera, A., and A. Willink. 1973. Biogeografía de América Latina. Ed. Secretaría General de la Organización de los Estados Americanos. Washington, D. C. pp 41 - 75.
- CERESIS (Centro Regional de Sismología para América del Sur). 1983. Maximum Intensity Map of South America, approximate scale 1:5,000,000.
- Clapperton, M. 1993. Quaternary Geology and Geomorphology of South America Elsevier Press, London, 779 pp.
- CORDECRUZ-KFW. 1995. Fisiografía y Suelos (Map of Physiography and Soils): Proyecto Plan de Protección de Recursos Naturales de Santa Cruz, Mapa IGM 13, scale 1:500,000.
- De Almeida, C. & J. De Paula. 1986. Contribuicao para Conhecimento da Flora do Pantanal Mato-Grossense e sua Relacao com Fauna e o Homem. Anais de 1o. Símposio sobre Recursos Naturais e Sócio-Económicos do Pantanal. Ed. Ministerio da Agricultura - MA; Empresa Brasileira de Pesquisa Agropecuária - EMBRAPA. Corumbá - Brasil. pp 107 - 130.
- Enron Gas Pipeline Operating Group. Operating Procedures Manual. Latest Rev. 1990.
- FAO/PNUMA. 1985. Un Sistema de Areas Silvestres Protegidas para el Gran Chaco. Basado en los resultados del taller sobre un sistema de áreas silvestres protegidas para el Gran Chaco. Ed. Oficina Regional de la FAO para América Latina y el Caribe. Asunción - Paraguay. 158 pp.

- GEOBOL (Servicio Geológico de Bolivia). 1978. Mapa de Cobertura y Uso Actual del Suelo, Bolivia (Map of Coverage and Current Soil Usage, Bolivia), Edición 1-P.E.B. (Preliminar), scale 1:1,000,000.
- IFC (International Finance Corporation), 1993. *Environmental Analysis and Review of Projects*. September, 1993.
- Kempff, N. 1985. Aves de Bolivia. Ed. Editorial Gisbert y Cia. S.A. La Paz - Bolivia. 156 pp.
- Kempff, N. 1975. Ofidios de Bolivia. Ed. Academia Nacional de Ciencias de Bolivia. 1ra ed. La Paz - Bolivia. 46 pp.
- National Research Council. 1993. Vetiver Grass: A Thin Green Line Against Erosion. National Academy Press. Washington, D.C.
- National Safety Council, Chicago, I11. 1990. "Accident Facts" - 1990 Edition.
- Navarro, G. 1992. Estudio de Parques Nacionales y Otras Areas Protegidas. Proyecto de Protección de los Recursos Naturales en el Departamento de Santa Cruz (Componente Proyecto Tierras Bajas). Cooperación Financiera del Gobierno Alemán; CORDECRUZ - KFW - CONSORCIO IP/SCG/KWC. Santa Cruz - Bolivia. 114 pp.
- Pareja, J.L. Pareja, C. Vargas., R. Suárez, R. Ballón, R. Carrasco, and C. Villaroel. 1978. Mapa Geológico de Bolivia, scale 1:1,000,000, and Memoria Explicativa, 27 pp.: Yacimientos Petrolíferos Fiscales Bolivianos y Servicio Geológico de Bolivia.
- Parker, T., A. Gentry, R. Foster, L. Emmons & J.V. Remsen. Jr. 1993. The Lowland Dry Forests of Santa Cruz, Bolivia. A Global Conservation Priority. Conservation International, RAP Working Papers 4. 104 pp.
- Sadud Q., Faisal. undated a. Estudio Geotécnico, Cruce Río Grande: geotechnical report prepared for YABOG-YPFB, 30 pp. plus attachments.
- Sadud Q., Faisal. undated b. Estudio Geotécnico, Cruce Río Parapeti: geotechnical report prepared for YABOG-YPFB, 7 pp. plus attachments.
- SECIPI-OPE; Cifd (ICI-AECI); CORDECRUZ. 1994. Informe Preliminar sobre los Recursos Naturales del Pantanal Boliviano (Area de San Matías). Memoria de las Prácticas del Curso "Conservación y Gestión de los Recursos Naturales: Aspectos Ecológicos". Santa Cruz - Bolivia. 62 pp.

Technical Paper No. 80. Involuntary Resettlement in Development Projects. 1988b

The Forest Sector: A World Bank Policy Paper. 1991d.

TOLEDO, M. 1995. Estudio Etnobotánico de los Chiquitanos de la Región de Lomerío en Santa Cruz - Bolivia. Tesis de Grado para optar el título de Lic. en Ciencias Biológicas. Universidad Autónoma "Gabriel René Moreno". Santa Cruz de la Sierra - Bolivia. 85 pp.

Tricart, J. 1982. El Pantanal: Un Ejemplo del Impacto Geomorfológico sobre el Ambiente: Informaciones Geográficas. Universidad de Chile, Santiago, Chile, vol. 29, pp. 81-97.

U.S. Department of Transportation. Washington, D.C. Annual Report On Pipeline Safety, Calendar Year 1989.

Van Den Berg. M.E. 1986. Formas Atuais e Potenciais de Aproveitamento das Espécies Nativas e Exóticas do Pantanal Mato-Grossense. Anais de 10. Símposio sobre Recursos Naturais e Sócio-Económicos do Pantanal. Ed. Ministerio da Agricultura - MA; Empresa

Villanueva, Edwin. 1996. Personal communication from Ing. Edwin Villanueva Trigo, Yacimientos Petrolíferos Fiscales Bolivianos, to Paul V. Smith, Dames & Moore, February 27, 1996.

Whiteside. 1996. Personal communication from Lowell S. Whiteside, National Oceanic and Atmospheric Administration (NOAA) National Geophysical Data Center, to Paul V. Smith, Dames & Moore, March 5, 1996.

World Bank, Operational Policy Note 11.02. Wildlands. 1986.

World Bank, Operational Directive 4.30. Involuntary Resettlement. 1990a.

World Bank, 1990a. Operational Directive 4.30: Involuntary Resettlement. *The World Bank Operational Manual*. June 1990.

World Bank, 1991a. *Environmental Assessment Sourcebook*. Volumes I, II, and III. World Bank Technical Papers Numbers 129, 140, 154. Environmental Department, the World Bank, Washington, D.C.

World Bank, Operational Directive 4.01. Environmental Assessment. 1991b.

World Bank, Operational Directive 4.20. Indigenous People. 1991c.



World Bank, 1994a. *Draft Environmental and Occupational Health and Safety Guidelines*.

World Bank, 1995 *The World Bank Atlas*.

YPFB (Yacimientos Petrolíferos Fiscales Bolivianos). 1994. Información "Sondeos Lecho Para Cruce Río Grande C/ Perforación Horizontal": Internal Communication, 8 pp. plus attachments, October 12, 1994.

**APPENDIX A**  
**ANALYSIS OF POTENTIAL IMPACTS  
TO AIR QUALITY**

***BOLIVIA-BRAZIL GAS PIPELINE PROJECT***

## APPENDIX A

### ANALYSIS OF POTENTIAL IMPACTS TO AIR QUALITY

#### 1.0 INTRODUCTION

This Air Quality Impact analysis for the proposed Bolivia-Brazil Gas Pipeline Project compressor stations addresses ambient air quality and in-stack considerations for compliance with Bolivian regulations and World Bank Guidelines. The World Bank Guidelines address onshore oil and gas operations which includes natural gas pipeline transmission systems.

For the ambient air impacts analysis, the simulator program SCREEN3 was used to screen- model the four compressor stations along the Bolivian portion of the proposed pipeline project. The pollutants evaluated were nitrogen oxides ( $\text{NO}_x$ ), carbon monoxide (CO) and particulate matter less than 10 microns in diameter ( $\text{PM}_{10}$ ). Modeled impacts were compared with current Bolivian National Ambient Air Quality Standards (NAAQS) and World Bank Guidelines for onshore oil and gas production.

Sections 2.0-5.0 address the ambient air quality impacts, while Section 6.0 addresses the in-stack standards and guidelines for Bolivia and the World Bank. Section 7.0 provides conclusions for this analysis.

#### 2.0 SCREEN3 MODEL DESCRIPTION

The most recent version of the simulation screening model, SCREEN3, was used in this air quality impact analysis. SCREEN3 is classified as a Gaussian model because the pollutant mass (i.e. concentration) is assumed to follow a bell-shaped curve, or normal distribution. When following a Gaussian distribution, the maximum concentrations associated with a source's emission plume are highest in the center of the plume and taper exponentially to almost zero in both the horizontal and vertical direction. The edge of an emission plume is defined as the point where the concentration drops to 10% of the centerline value.

SCREEN3 is a very simplistic model; however, the model is well suited for screening a source's potential impact on the air quality of a region. Primarily, SCREEN3 is used to perform *single source*, short-term calculations that estimate maximum off-site ground-level concentrations. SCREEN3 also provides the distance to the maximum off-site impact, incorporates the effects of building downwash on the maximum concentrations for both the near wake and far wake regions, estimates concentrations in the cavity recirculation zone, and estimates concentrations due to inversion break-up and shoreline fumigation. In addition, the model can be used to evaluate the effects of simple elevated terrain on maximum concentrations. It also estimates 24-hour average concentrations due to plume impaction in complex terrain using the VALLEY model 24-hour screening procedure. The SCREEN3 model will calculate the maximum concentration at any number of user-specified distances in flat or elevated simple terrain, including distances out to 100 km for long-range transport.

## 2.1 SCREEN3 APPLIED TO PROPOSED PIPELINE PROJECT

SCREEN3 was used to predict the highest off-site impacts associated with the compressor stations along the pipeline. Two sets of screen modeling runs were performed for each pollutant, NO<sub>x</sub>, CO, and PM<sub>10</sub>, to evaluate the impacts from both the CENTAUR 50 and TAURUS 60 natural-gas fueled combustion turbines. Both compressor units were evaluated because detail design is not complete at this time, and the mechanical unit of choice has not been selected. Additionally, two modeling scenarios were simulated with the use of SCREEN3. The first scenario considers four turbines housed in one building with only three in operation at any given time and the fourth serving as a stand-by unit. This scenario simulated three of the compressor stations along the pipeline. The second scenario was to simulate only one turbine in operation at the fourth station along the pipeline.

Each compressor station was simulated housing the turbines in the compressor building, with the emission stack roughly 3.5 meters above the building height. The dimensions of the building used in the simulation for downwash calculations in SCREEN3 are given below.

Structure	Structure Height (meters)	Structure Width (meters)	Structure Length (meters)
Compressor Building	7.6 (25 ft)	6.0 (20 ft)	12.0 (39 ft)

The algorithms in SCREEN3 designed to simulate impacts in simple and complex terrain were not necessary since it was assumed that the entire length of the pipeline will stretch across relatively flat terrain. Simple terrain is defined as terrain existing above the stack base, but below the top of the stack. Complex terrain on the other hand is terrain existing above stack height. Rural dispersion coefficients were used to simulate stability parameters in a forested/grassland region.

### 3.0 METEOROLOGICAL DATA SET

SCREEN3 does not allow for the use of actual meteorological data. Instead, the data used are a "worst-case" combination of wind speed and stability parameters. SCREEN3 evaluates a range of wind speeds (1.0 m/s - 20.0 m/s) and six stability classes ranging from unstable (well mixed atmosphere), through neutral, to stable (essentially no mixing), and selects the "worst-case" combination that will result in the highest ground-level concentration.

As mentioned above, stability classes describe the lower layers of the atmosphere in terms of how well it is "mixed". The mixing height in meteorological terms is defined as the depth of a layer in the atmosphere where thermal and mechanical turbulence provide mixing of air parcels before being damped out by more stable air aloft. The depth of the mixed layer is a key factor in model predictions of ground-level concentrations of pollutants. For instance, an emission plume that is trapped within a very shallow mixing layer near the ground often results in very high ground-level concentrations, and in many cases exceedances of allowable ground-level concentrations. SCREEN3 automatically calculates the mixing height in unstable and neutral conditions (i.e., 4 of the 6 stability classes). The mixing height is not used for stable conditions.

Unlike the meteorological data sets used with ISCST3 (a more refined Gaussian model), wind direction is not important when using SCREEN3. SCREEN3 looks in only one direction, predicting impacts at user-specified distances. This is obviously not very realistic, however, the

purpose of screen modeling is to quickly get an "absolute, worst-case" estimate of the source (s) impact on the air quality of the region.

#### 4.0 MODELED PARAMETERS

The two screen modeling runs were built using the stack parameters listed in the table below. Only the exit velocity and the effluent temperature differ from one turbine to the other.

Compressor Building Stack	Stack Exit Velocity (m/s)	Stack Height (meters)	Stack Diameter (meters)	Stack Exit Temperature (K)
CENTAUR 50	43.63	12.0	1.10	785.9
TAURUS 60	48.10	12.0	1.10	755.4

The CENTAUR 50 turbine has a horsepower (hp) rating of 5680 hp. The TAURUS 60 turbine is rated at 6960 hp.

#### 5.0 PREDICTED RESULTS WITH A COMPARISON TO BOLIVIAN NAAQS AND WORLD BANK GUIDELINES

A total of six SCREEN3 modeling runs were used to predict the impact on the air quality of the proposed compressor stations along the pipeline. Two modeling runs were set up to evaluate the impacts from both the CENTAUR 50 and the TAURUS 60 natural-gas fueled turbines. For each of these modeling runs, a set up was developed for each pollutant emitted from the compressor building stack. NO<sub>x</sub>, CO and PM<sub>10</sub> emissions were evaluated for each turbine for a total of six SCREEN3 modeling runs. The two types of turbines modeled are fueled by natural gas and the sulfur content of the gas is considered negligible, thus no significant (in terms of modeling) sulfur dioxide emissions were expected.

The scenario of three turbines operating together was simulated by taking the predicted SCREEN3 impacts for one turbine in operation, and multiplying by three to obtain the impacts associated

with three turbines in operation simultaneously. This conservative assumption was used to simplify the analysis and evaluate a "worst case" scenario.

## **5.1 PREDICTED NO<sub>x</sub> IMPACTS**

### **5.1.1 Comparison to Bolivian NAAQS**

Off-site impacts for NO<sub>x</sub> emissions from the compressor operations were predicted for the CENTAUR 50 and TAURUS 60 turbines. The two sub-sections below (5.1.3 and 5.1.4) contain the tables for the two operating scenarios for NO<sub>x</sub> impacts. The maximum 1-hour impact associated with the CENTAUR 50 was 128.6 μg/m<sup>3</sup> and was located at a distance of 76 meters from the compressor building. The predicted impact for three CENTAUR 50's in operation simultaneously was 385.8 μg/m<sup>3</sup>. For a set of three TAURUS 60's, the highest predicted impact was 441.0 μg/m<sup>3</sup> at a distance of 76 meters from the source. The Bolivian 1-Hour NO<sub>x</sub> NAAQS is 400 μg/m<sup>3</sup> and for the three turbines operating simultaneously, SCREEN3 predicted an exceedance of the NAAQS for the TAURUS 60's only. Likewise, SCREEN3 predicted an exceedance of the 24-Hour Bolivian NO<sub>x</sub> NAAQS of 150 μg/m<sup>3</sup> for the three TAURUS 60's and the three CENTAUR 50's as well. SCREEN3 predicted no exceedances of the Bolivian NO<sub>x</sub> NAAQS for either the CENTAUR 50 or TAURUS 60 in the scenario of one turbine at a compressor station.

### **5.1.2 Comparison to World Bank Guidelines**

All predicted impacts were in compliance with the World Bank Guidelines and can be seen in Sections 5.1.3-5.1.4. The World Bank Guidelines allow for ground-level concentrations of NO<sub>x</sub> to be less than or equal to 200 μg/m<sup>3</sup> for the 24-hour averaging period and less than or equal to 100 μg/m<sup>3</sup> on an annual basis.

### 5.1.3 NO<sub>x</sub> Impacts For Three Compressors Operating Simultaneously

Compressor	Modeled Emission Rate (g/s)	Predicted Off-site Impact <sup>a</sup> (μg/m <sup>3</sup> )			Bolivian NAAQS (μg/m <sup>3</sup> )		World Bank Guidelines (μg/m <sup>3</sup> )		Source-Max Impact Distance (meters)
		1-hr	24 -hr	Ann	1-hr	24-hr	24-hr	Ann	
CENTAUR 50	10.08	385.8	154.32 <sup>b</sup>	30.86 <sup>c</sup>	400.00	150.00	200.00	100.00	76.00
TAURUS 60	11.88	441	176.40 <sup>b</sup>	35.28 <sup>c</sup>	400.00	150.00	200.00	100.00	76.00

- a The predicted impacts do not include existing NO<sub>x</sub> background concentrations. The background concentrations are not known at this time.
- b 24-Hour average obtained by multiplying SCREEN3 1-hour impact by 0.4
- c annual average obtained by multiplying SCREEN3 1-hour impact by 0.08

### 5.1.4 NO<sub>x</sub> Impacts For One Compressor

Compressor	Modeled Emission Rate (g/s)	Predicted Off-site Impact <sup>a</sup> (μg/m <sup>3</sup> )			Bolivian NAAQS (μg/m <sup>3</sup> )		World Bank Guidelines (μg/m <sup>3</sup> )		Source-Max Impact Distance (meters)
		1-hr	24 -hr	Ann	1-hr	24-hr	24-hr	Ann	
CENTAUR 50	3.36	128.6	51.44 <sup>b</sup>	10.28 <sup>c</sup>	400.00	150.00	200.00	100.00	76.00
TAURUS 60	3.97	147	58.80 <sup>b</sup>	11.76 <sup>c</sup>	400.00	150.00	200.00	100.00	76.00

- a The predicted impacts do not include existing NO<sub>x</sub> background concentrations. The background concentrations are not known at this time.
- b 24-Hour average obtained by multiplying SCREEN3 1-hour impact by 0.4
- c annual average obtained by multiplying SCREEN3 1-hour impact by 0.08



## 5.2 PREDICTED CO IMPACTS

### 5.2.1 Comparison to Bolivian NAAQS/World Bank Guidelines

SCREEN3 predicted impacts for CO were well below the allowable concentrations set forth in the Bolivian NAAQS. The predicted impacts were nearly the same for both turbine models. The results of the screen modeling for CO can be seen in the two tables below. Impacts from CO are not anticipated to contribute to any air quality reduction in the region. The World Bank Guidelines contain no limits on CO emissions. The tables in sections 5.2.2 thru 5.2.3 indicate this by N/A in place of the standard.

### 5.2.2 CO Impacts For Three Compressors Operating Simultaneously

Compressor	Modeled Emission Rate (g/s)	Predicted Off-site Impact <sup>a</sup> ( $\mu\text{g}/\text{m}^3$ )		Bolivian NAAQS ( $\mu\text{g}/\text{m}^3$ )		World Bank Guidelines ( $\mu\text{g}/\text{m}^3$ )		Source-Max Impact Distance (meters)
		1-hr	8-hr	1-hr	8-hr	1-hr	8-hr	
CENTAUR 50	0.7635	87.69	61.38 <sup>b</sup>	40000	10000	N/A	N/A	76.00
TAURUS 60	0.8450	94.11	65.87 <sup>b</sup>	40000	10000	N/A	N/A	76.00

a The predicted impacts do not include existing CO background concentrations. The background concentrations are not known at this time.

b 8-Hour average obtained by multiplying SCREEN3 1-hour impact by 0.7

### 5.2.3 CO Impacts for One Compressor

Compressor	Modeled Emission Rate (g/s)	Predicted Off-site Impact <sup>a</sup> ( $\mu\text{g}/\text{m}^3$ )		Bolivian NAAQS ( $\mu\text{g}/\text{m}^3$ )		World Bank Guidelines ( $\mu\text{g}/\text{m}^3$ )		Source-Max Impact Distance (meters)
		1-hr	8-hr	1-hr	8-hr	1-hr	8-hr	
CENTAUR 50	0.7635	29.23	20.46 <sup>b</sup>	40000	10000	N/A	N/A	76.00

Compressor	Modeled Emission Rate (g/s)	Predicted Off-site Impact <sup>a</sup> ( $\mu\text{g}/\text{m}^3$ )		Bolivian NAAQS ( $\mu\text{g}/\text{m}^3$ )		World Bank Guidelines ( $\mu\text{g}/\text{m}^3$ )		Source-Max Impact Distance (meters)
		1-hr	8-hr	1-hr	8-hr	1-hr	8-hr	
TAURUS 60	0.8450	31.37	21.96 <sup>b</sup>	40000	10000	N/A	N/A	76.00

- a The predicted impacts do not include existing CO background concentrations. The background concentrations are not known at this time.
- b 8-Hour average obtained by multiplying SCREEN3 1-hour impact by 0.7

### 5.3 PM<sub>10</sub> PREDICTED IMPACTS

#### 5.3.1 Comparison to Bolivian NAAQS/World Bank Guidelines

The predicted impacts for PM<sub>10</sub> were well below the allowable concentrations given in both the Bolivian NAAQS and World Bank Guidelines for both types of turbines and both operating scenarios. The results are in the tables below.

#### 5.3.2 PM<sub>10</sub> Impacts for Three Compressors Operating Simultaneously

Compressor	Modeled Emission Rate (g/s)	Predicted Off-site Impact <sup>a</sup> ( $\mu\text{g}/\text{m}^3$ )		Bolivian NAAQS ( $\mu\text{g}/\text{m}^3$ )		World Bank Guidelines ( $\mu\text{g}/\text{m}^3$ )		Source-Max Impact Distance (meters)
		24-hr	Ann	24-hr	Ann	24-hr	Ann	
CENTAUR 50	0.0252	1.1577 <sup>b</sup>	0.2315 <sup>c</sup>	150.00	50.00	500.00	100.00	76.00
TAURUS 60	0.0252	1.1226 <sup>b</sup>	0.2245 <sup>c</sup>	150.00	50.00	500.00	100.00	76.00

- a The predicted impacts do not include existing PM<sub>10</sub> background concentrations. The background concentrations are not known at this time.
- b 24-hour average obtained by multiplying SCREEN3 1-hour impact by 0.4
- c Annual average obtained by multiplying SCREEN3 1-hour impact by 0.08

### 5.3.3 PM<sub>10</sub> Impacts for One Compressor

Compressor	Modeled Emission Rate (g/s)	Predicted Off-site Impact <sup>a</sup> (μg/m <sup>3</sup> )		Bolivian NAAQS (μg/m <sup>3</sup> )		World Bank Guidelines (μg/m <sup>3</sup> )		Source-Max Impact Distance (meters)
		24-hr	Ann	24-hr	Ann	24-hr	Ann	
CENTAUR 50	0.0252	0.3859 <sup>b</sup>	0.0772 <sup>c</sup>	150.00	50.00	100.00	50.00	76.00
TAURUS 60	0.0252	0.3742 <sup>b</sup>	0.0748 <sup>c</sup>	150.00	50.00	100.00	50.00	76.00

- a The predicted impacts do not include existing PM<sub>10</sub> background concentrations. The background concentrations are not known at this time.
- b 24-hour average obtained by multiplying SCREEN3 1-hour impact by 0.4
- c Annual average obtained by multiplying SCREEN3 1-hour impact by 0.08

## 6.0 IN-STOCK EMISSIONS STANDARDS AND GUIDELINES

For certain criteria pollutants, Bolivia has in-stack emissions standards. Additionally, the World Bank has in-stack guidelines which should be assessed.

### 6.1 EMISSION RATES IN COMPARISON TO BOLIVIAN STANDARDS<sup>1</sup>

The following table demonstrates compliance with the applicable Bolivian emission standards.

Pollutant	Emission Rate		In-Stack Bolivian Standard <sup>2</sup> Kg/10m <sup>3</sup>
	Centaur Unit Kg/Nm <sup>3</sup>	Taurus Unit Kg/Nm <sup>3</sup>	
PM <sub>10</sub>	0.0006	0.0006	50
SO <sub>2</sub>	negligible	negligible	9.6
CO	0.02	0.02	640
NO <sub>x</sub>	0.09	0.09	8800

<sup>1</sup> Anexo 4

<sup>2</sup> Kilograms per 10 cubic meters of natural gas consumed

## 6.2 EMISSION RATES IN COMPARISON TO WORLD BANK GUIDELINES

The following table demonstrates compliance with the World Bank in-stack emission guidelines.

Pollutant	Emission Rate		In-Stack World Bank Guidelines <sup>a</sup> mg/Nm <sup>3</sup>
	Centaur Unit mg/Nm <sup>3</sup>	Taurus Unit mg/Nm <sup>3</sup>	
PM <sub>10</sub>	1.70	1.50	100
SO <sub>2</sub>	negligible	negligible	1000
CO	N/A	N/A	N/A
NO <sub>x</sub>	221	228	600

a From the World Bank Guidelines for Natural Gas Pipeline Transmission Systems

N/A = not applicable

## 7.0 CONCLUSIONS

### 7.1 IN-STACK BOLIVIAN EMISSION STANDARDS

The project emission rates are well below any of the Bolivian air emission standards for PM<sub>10</sub>, SO<sub>2</sub>, CO and NO<sub>x</sub>.

### 7.2 IN-STACK WORLD BANK EMISSION GUIDELINES

The in-stack emissions for PM<sub>10</sub>, SO<sub>2</sub>, and NO<sub>x</sub> are well below the World Bank Emission Guidelines for the gas turbine sources.

### 7.3 BOLIVIAN NAAQS

SCREEN3 predicted exceedances of the Bolivian 1-hour and 24-hour NO<sub>x</sub> NAAQS for the three TAURUS 60 turbines. The three CENTAUR 50 turbines had a predicted exceedance of the 24-hour NO<sub>x</sub> NAAQS as well. The three TAURUS 60's exceeded the 1-hour NO<sub>x</sub> NAAQS by 41 μg/m<sup>3</sup> for the scenario of three turbines in operation simultaneously. The 24-hour NO<sub>x</sub> NAAQS was exceeded by nearly 4 μg/m<sup>3</sup> for the CENTAUR 50 (three turbines operating) and by nearly 26 μg/m<sup>3</sup> for the TAURUS 60 (three turbines operating). No exceedances were predicted for CO and PM<sub>10</sub> when compared to the Bolivian NAAQS.

### 7.4 WORLD BANK GUIDELINES FOR AMBIENT AIR QUALITY

No exceedances of the World Bank Guidelines for ambient air quality were predicted for any of the pollutants modeled.

### 7.5 SOLUTIONS TO PREDICTED AIR QUALITY PROBLEMS

Further analysis of the SCREEN3 modeling results revealed that the impacts fell below the Bolivian 1-hour and 24-hour NO<sub>x</sub> NAAQS at a distance of roughly 92 meters (300 ft) from the compressor building for the TAURUS 60 turbine. For the CENTAUR 50, the impacts fall below the 24-hour NO<sub>x</sub> NAAQS at a distance of 79 meters (259 ft) from the compressor building. If the property-line surrounding the compressor stations could be expanded to these distances, then compliance with the Bolivian NO<sub>x</sub> NAAQS could be attained.

Compliance with the standards could also be achieved by raising the compressor building stack height. The current stack height is not high enough to allow the plume to escape the influence of the airflow around the compressor building (i.e. downwash effects). Many times, source emissions are "caught" by the vertically circulating region of air downwind of structures, known as the cavity region. Depending on the height of the stack, the entire pollutant mass may be entrained or only a small portion. Perhaps one of the most useful features of air dispersion modeling is its ability to serve as a design tool. By raising or lowering the stack height, a prediction can be made as to how much of the pollutant mass within a plume will be

entrained into the cavity region. The idea is to design a stack height that will be cost effective and keep the plume high enough above this cavity region as to prevent high pollutant concentrations from being brought to the ground before the pollutant mass has had a sufficient time to disperse.

For the Bolivian pipeline modeling, a portion of the plume is being brought to the ground at a distance of 76 meters from the source with the predicted impacts exceeding the Bolivian standards for  $\text{NO}_x$ . A couple of SCREEN3 "design runs" have been performed and it was determined that compliance with the Bolivian  $\text{NO}_x$  NAAQS can be attained by increasing the stack height by just one meter (i.e. raising the current height of 12.0 meters to 13.0 meters).

Another alternative for lowering predicted impacts is to perform refined air dispersion modeling. As stated earlier, SCREEN3 modeling is extremely conservative and over-predictive. Refined modeling techniques would utilize the ISCST3 model; a model that is more realistic and far less over-predictive. The advantages of using ISCST3 to determine source impacts on existing air quality are its use of "actual" meteorological data, and a more accurate simulation of downwash effects from buildings on a source's emissions.

**APPENDIX B**

**ENVIRONMENTAL**

**MANAGEMENT**

**PLAN**

**BOLIVIA-BRAZIL PIPELINE PROJECT**

**TABLE OF CONTENTS**

**ENVIRONMENTAL MANAGEMENT PLAN**

<u>Section</u>	<u>Page</u>
1.0 INTRODUCTION .....	B-1
1.1 OBJECTIVES .....	B-1
1.2 ORGANIZATION .....	B-1
1.3 RESPONSIBILITIES .....	B-2
1.4 SCHEDULE .....	B-2
2.0 ENVIRONMENTAL MANAGEMENT STRATEGIES .....	B-3
2.1 PRECONSTRUCTION STRATEGIES .....	B-3
2.2 WORKERS ENVIRONMENTAL TRAINING .....	B-3
2.3 CONSTRUCTION SUPERVISION AND INSPECTION .....	B-4
2.4 MONITORING .....	B-6
2.5 COMMUNITY RELATIONS .....	B-7
3.0 STANDARD CONSTRUCTION .....	B-7
3.1 EROSION AND SEDIMENT CONTROL .....	B-7
3.2 CLEARING .....	B-8
3.2.1 Standard Procedures .....	B-8
3.2.2 Useable Timber .....	B-9
3.2.3 Trees and Brush Disposal .....	B-9
3.3 GRADING .....	B-10
3.3.1 Removal of Tree Stumps .....	B-11
3.3.2 Disposal of Tree Stumps .....	B-11
3.3.3 Rock Disposal .....	B-11
3.3.4 Water Bars/Terraces (Slope Breakers) .....	B-12
3.3.5 Erosion Control Barriers/Structures .....	B-13
3.3.6 Filter Fabric Fence Installation .....	B-13
3.4 DITCHING .....	B-13
3.4.1 Topsoil Segregation .....	B-13



*ENVIRONMENTAL MANAGEMENT PLAN*

3.4.2	Underground Utilities . . . . .	B-14
3.4.3	Temporary Ditch Plugs . . . . .	B-14
3.5	LOWERING-IN/BACKFILLING . . . . .	B-15
3.5.1	Trench Dewatering . . . . .	B-15
3.5.2	Padding . . . . .	B-16
3.5.3	Trench Breakers . . . . .	B-16
3.5.4	Backfilling . . . . .	B-17
3.5.5	Use or Disposal of Blast Rock . . . . .	B-17
3.6	HYDROSTATIC TESTING . . . . .	B-17
3.7	RESTORATION AND REVEGETATION . . . . .	B-19
3.7.1	Temporary Erosion Control . . . . .	B-19
3.7.2	Permanent Restoration Measures . . . . .	B-19
3.7.3	Permanent Water Bars . . . . .	B-20
3.7.4	Contour Wattling . . . . .	B-20
3.7.5	Revegetation and Seeding . . . . .	B-21
3.7.6	Mulching . . . . .	B-21
3.8	SAFETY . . . . .	B-22
3.9	ACCESS ROADS . . . . .	B-22
4.0	SPECIALIZED CONSTRUCTION . . . . .	B-22
4.1	BLASTING . . . . .	B-23
4.2	THE TWO-TONE APPROACH . . . . .	B-24
4.3	DRAG SECTIONS . . . . .	B-24
4.4	STOVEPIPE . . . . .	B-24
4.5	RESIDENTIAL AREA CONSTRUCTION . . . . .	B-25
4.6	BORING . . . . .	B-25
4.7	JACKING . . . . .	B-25
4.8	DIRECTIONAL DRILLING . . . . .	B-26
4.9	EQUIPMENT CROSSOVERS . . . . .	B-26
4.10	AGRICULTURAL AREA CONSTRUCTION . . . . .	B-26
4.10.1	Grading . . . . .	B-27
4.10.2	Ditching\Lowering\Backfilling . . . . .	B-27
4.10.3	Restoration and Revegetation . . . . .	B-27
4.11	WETLAND CROSSINGS . . . . .	B-28
4.11.1	General Measures . . . . .	B-28
4.11.2	Additional Work Space Areas . . . . .	B-29
4.11.3	Spoil Pile Placement/Control . . . . .	B-29
4.11.4	Wetland Crossing Procedures . . . . .	B-29
4.11.4.1	Method I: Standard Pipeline Construction . . . . .	B-30

## ENVIRONMENTAL MANAGEMENT PLAN

4.11.4.2	Method II: Conventional Wetland Construction	B-32
4.11.4.3	Method III: Push/Pull Wetland Construction	B-34
4.12	WATERBODY CROSSINGS	B-37
4.12.1	General Measures	B-37
4.12.2	General Procedures	B-38
4.12.3	Waterbody Crossing Procedures	B-39
4.12.3.1	Method I: Wet Crossings	B-39
4.12.3.2	Method II: Other (Site-Specific Crossings)	B-41
4.13	COMBINED WETLAND/WATERBODY CROSSINGS	B-41
5.0	SPILL PREVENTION AND CONTROL PLAN	B-41
5.1	PREVENTATIVE MEASURES	B-41
5.1.1	Training	B-41
5.1.2	Equipment Inspection and Maintenance	B-42
5.1.3	Refueling	B-42
5.1.3.1	Refueling Operations	B-42
5.1.3.2	Conditions	B-43
5.1.4	Storage	B-44
5.2	MITIGATION MEASURES	B-44
5.2.1	Containment	B-44
5.2.2	Clean up	B-44
5.2.3	Notification	B-45
5.2.4	Excavation and Disposal	B-45
5.2.4.1	Small Spills	B-45
5.2.4.2	Large Spills	B-45
5.2.5	Reporting	B-45
5.3	CLEAN UP EQUIPMENT	B-46
5.3.1	TERRESTRIAL CONSTRUCTION	B-46
5.3.1.1	General	B-46
5.3.1.2	Fuels and Lubricating Oil Storage	B-47
5.3.1.3	Routine Refueling and Maintenance	B-47
5.3.1.4	Equipment Failure	B-47
5.3.2	Waterbody and Wetland Crossings	B-47
6.0	WASTE AND HAZARDOUS MATERIALS MANAGEMENT AND DISPOSAL	B-48
6.1	SOLID WASTE	B-48
6.2	SANITARY WASTE	B-48
6.3	HAZARDOUS WASTE	B-48

*ENVIRONMENTAL MANAGEMENT PLAN*

7.0	AIR QUALITY PROTECTION AND NOISE CONTROL .....	B-49
7.1	AIR QUALITY .....	B-49
7.2	NOISE CONTROL .....	B-49
8.0	VEGETATION AND WILDLIFE PROTECTION .....	B-49
8.1	GENERAL .....	B-49
8.2	SPECIES OF SPECIAL CONCERN .....	B-50
9.0	ACCIDENTAL DISCOVERY OF CULTURAL RESOURCES AND HUMAN REMAINS .....	B-51
9.1	CULTURAL RESOURCES .....	B-51
	9.1.1 Identification .....	B-51
	9.1.2 Treatment .....	B-52
9.2	HUMAN REMAINS .....	B-53
10.0	ABANDONMENT .....	B-54
11.0	COMPENSATORY MITIGATION PROGRAM .....	B-54
12.0	COST OF THE EMP .....	B-55

**LIST OF TABLES**

<u>No.</u>	<u>Description</u>
EMP-1	List of Endemic, Endangered, and Economically Important Plant and Animal Species in the Study Area
EMP-2	Summary of Estimated Costs Associated with the Implementation of the Environmental Management Program

**LIST OF FIGURES**

<u>No.</u>	<u>Description</u>
1	Typical Construction Right-of-Way
2	Filter Fence Construction
3	Typical Trench Breakers
4	Permanent Water Bars or Terraces
5	Contour Wattling
6	Typical Erosion Control Fabric
7	Typical ROW in Agricultural Areas
8	Conventional Wetland Construction (Method II)
9	Push/Pull Wetland Construction (Method III)
10	Wet Waterbody Crossing (Method I)

## **1.0 INTRODUCTION**

### **1.1 OBJECTIVES**

This Environmental Management Plan (EMP) is a planning tool that establishes guidelines and procedures to manage environmental impacts of the Bolivia to Brazil Gas Pipeline Project. The EMP presents the project guidelines on environmental management strategies, specialized environmental construction procedures, spill prevention and control, waste and hazardous materials management and disposal, air quality protection and noise control, vegetation and wildlife protection, accidental discovery of cultural resources and human remains, and abandonment procedures. The EMP also includes a compensatory mitigation program designed to offset potential impacts in the vicinity of the Gran Chaco National Park.

The main objectives of the EMP are: 1) To avoid, minimize, control, or mitigate potential impacts from the project construction and operation on the physical, biological, and socioeconomic environment, and 2) To ensure continued project compliance with applicable environmental regulations.

The pipeline route and the location of associated facilities were selected in an effort to minimize physical, biological, cultural and socio-economic impacts while making the project economically feasible. However, some unavoidable impacts will occur as a result of construction and operation of the pipeline. Most of the impacts to soils, water quality, and to some extent vegetation and wildlife, will be localized and temporary. These impacts can be controlled or limited to acceptable levels by the application of mitigating measures during and after construction.

The environmental management measures presented in this chapter provide a conceptual approach to establish the environmental procedures to be followed in the execution of the project.

### **1.2 ORGANIZATION**

Due to its complexity and scope, the implementation of the EMP will be executed utilizing a specific organization and specific funding support. An Environmental Manager will coordinate the activities of a technical staff responsible for monitoring and managing EMP compliance.

The Environmental Manager will also be responsible for technical, community, and administrative matters relating to the EMP. The Environmental Manager will be responsible for monitoring compliance with the EMP and will be assisted by an appropriate staff to address all technical questions and project-specific issues relating to the EMP, including liaison between the general public and environmental issues related to the project. This person will interact with local

communities to keep them informed of the project's events and to properly address any items of concern.

### **1.3 RESPONSIBILITIES**

In the execution of this EMP and its associated monitoring and inspections, the responsible parties will be as follows:

**The Project Sponsors** are responsible for providing all necessary funding and administrative support to the EMP. The Project Sponsors are ultimately responsible for carrying out this project within acceptable environmental standards.

**The Environmental Manager**, who will work for the Project Sponsors, will be responsible for coordinating the activities of a technical staff responsible for monitoring and managing EMP compliance.

**The Environmental Inspectors**, will be responsible for monitoring EMP compliance and reporting to the Environmental Manager.

**The Construction Contractor** will be responsible for compliance with the environmental measures related to construction activities described in this EMP.

### **1.4 SCHEDULE**

The implementation of the EMP will begin at the final design stage. Project specifications will be better defined to avoid or minimize potential impacts identified in the Environmental Impact Assessment. During the pre-construction phase a project Environmental Department will be established by the Project Sponsors.

Once a Construction Contractor is hired, environmental training of workers will take place. The Environmental Inspectors will be hired and trained in time to begin their activities as the construction begins.

A contribution will be made to the Endowment Fund at the commencement of commercial operations of the project.

During construction, the EMP will be in full operation, with implementation being the responsibility of the Contractor, and monitored by the Environmental Inspectors.

## 2.0 ENVIRONMENTAL MANAGEMENT STRATEGIES

### 2.1 PRECONSTRUCTION STRATEGIES

Some general mitigation measures are applicable during the final design and preconstruction activities, including the following:

- *Establish an Adequate Construction Schedule.* The construction schedule will be developed to the extent possible to minimize potential adverse impacts due to seasonal considerations.
- *Design Construction Areas in Order to Minimize Impacts.* Final design will favor the use of previously disturbed areas and avoidance of environmentally sensitive areas. The construction area will be minimized while providing necessary work space.
- *Construction of Fences and Gates.* Temporary fences, gates and other devices will be installed to clearly indicate construction areas and restrict access to sensitive areas.
- *Establish Access Restrictions.* Access routes will be monitored as needed to avoid unauthorized entry into the project area.
- *Conduct a Pre-Construction Survey of Right-of-Way Conditions.* A pre-construction survey will be conducted to finalize alignment, determine topography, identify conflicts, identify land owners, land use and other site characteristics necessary to complete the detail design and construction.

### 2.2 WORKERS ENVIRONMENTAL TRAINING

Environmental training will be provided to all employees prior to commencement of work. New workers brought to the project after the initiation of project activities will receive training as soon as is practicable following their arrival. Training will include the following topics:

- Right-of-way
- Community relations
- Erosion control
- Wetlands
- Streams and water bodies
- Water withdrawal and discharge



- Spill prevention, control, and containment
- Species of special concern
- Cultural resources
- Contingency plan

A formal training curriculum will be developed consisting of a written and pictorial presentation of information covering the topics above and a video providing verbal instruction on the topics.

### **2.3 CONSTRUCTION SUPERVISION AND INSPECTION**

The project will have a Chief Environmental Inspector and will use at least one qualified Environmental Inspector (EI) per construction spread. The project will conduct in-house Environmental Inspector training to ensure that the Environmental Inspectors will be able to carry out their assigned duties and that construction activities will be in compliance with requirements of applicable environmental licenses and permits. The Environmental Inspectors will review all project documents (right-of-way descriptions, licenses, alignment sheets, aerial photography and relevant plans) prior to construction. The inspectors will also be responsible for:

1. Identifying areas that require stabilization;
2. Ensuring all erosion and sedimentation control devices are installed and maintained properly;
3. Monitoring restoration of upland areas, waterbodies and wetlands;
4. Ensuring that all construction activities occur within authorized work areas and only approved access roads are used;
5. Ensuring that the requirements set forth in the Spill Prevention Containment and Control Plan (Section 5.0 of this EMP) are met;
6. Monitoring waste collection and disposal;
7. Inspecting construction activities daily to verify and document that contractors are complying with the requirements of this EMP, the environmental provisions included in the construction drawings and the environmental conditions of the license;

## *ENVIRONMENTAL MANAGEMENT PLAN*

8. Photo-documenting the condition of sensitive areas and work spaces prior to, throughout, and after construction;
9. Documenting (including photos/videos) construction activities;
10. Identifying potential problems and initiating appropriate actions prior to occurrence;
11. Ensuring that the soil profile is restored as required;
12. Educating other Inspectors on project specific environmental concerns;
13. Ensuring the repair of all ineffective temporary erosion control measures as soon as possible after identification;
14. Marking of surface and subsurface drainage and irrigation system locations;
15. Performing tests of subsoil and topsoil where appropriate to determine the extent of compaction across the disturbed ROW in agricultural areas;
16. Approving of imported soils used as fill and/or additional cover material in sensitive areas (i.e., agricultural, residential and wetland areas);
17. Monitoring hydrostatic test fill and spill activities and conducting required sampling of the test water; and
18. Ensuring that Waterbody and Wetland Crossing Plans are properly implemented;
19. Locating dewatering structures and slope breakers to ensure they will not direct water into known cultural resource sites or locations of sensitive species;
20. Verifying that trench dewatering activities do not result in the deposition of sand, silt, and/or sediment near the point of discharge into a wetland or waterbody. If such deposition is occurring, the design of the discharge shall be altered to prevent reoccurrence;
21. Advising the Chief Environmental Inspector when conditions (such as wet weather) make it advisable to restrict construction activities in agricultural areas.

The Environmental Inspector will be required to use best judgment in the field at all times to ensure that violations, audits, and other environmental related documentation are transmitted to

appropriate project personnel. Each Environmental Inspector will have peer status with the other inspectors. The Environmental Inspector will report compliance problems to the Environmental Manager.

A Safety Inspector will be responsible for ensuring and documenting that safe conditions are maintained throughout construction.

## **2.4 MONITORING**

During construction, monitoring will be part of the inspection program. Environmental monitoring may include, but not be limited to, erosion control, water quality, indigenous and protected wildlife species, cultural resources, water resources, vegetation, and protected areas.

As stated earlier under the section pertaining to the Environmental Inspector's duties and responsibilities, the Environmental Inspector will prepare a plan to monitor the success of revegetation and stabilization of the right-of-way and temporary work areas following construction.

Monitoring will also include visual inspection and documentation of establishment of temporary vegetation for sediment and substrate stabilization. If deficiencies in the establishment of temporary vegetation cover are discovered, the Environmental Inspector will develop a plan of remediation and implement that plan. All erosion control devices are to remain in place and in a functional condition until stabilization is achieved.

Once stabilization is achieved, all temporary erosion and sedimentation control devices will be removed. All such materials removed will be disposed of in compliance with applicable regulations and conditions of permits/certifications for the project.

During routine inspections of the ROW, personnel will also make visual observations of the re-establishment of native vegetation within disturbed areas. The amount of native vegetational cover returning within areas disturbed by construction will be documented.

During operations, periodic route inspections will be made to identify if the right-of-way shows signs of erosion and if vegetation is being reestablished. These assessments will be made semi-annually during the first two years, and annually thereafter until the area is stabilized. If indicated, remedial action will be implemented.

## 2.5 COMMUNITY RELATIONS

As part of the management of the project, the sponsors will maintain a Community Relations program aimed at promoting good relations with the communities in the area of influence of the project, as well as providing environmental education and increasing awareness about the project and the environment.

The community relations program will include the following components:

1. Maintaining a Public Liaison during construction.
2. Developing an environmental education program.
3. Developing a public information program about the project.
4. Educating the construction labor force regarding proper relations with the host communities.

## 3.0 STANDARD CONSTRUCTION

Construction of a natural gas pipeline consists of distinct phases: clearing, grading, ditching, lowering-in, backfilling, hydrostatic testing and restoration. The construction methods described herein will be used unless site-specific conditions warrant special methods. Figure 1 shows a typical ROW configuration depicting the typical sequence of construction activities that will take place.

Preconstruction surveys will be conducted to determine the specific needs of the project. Information on soils was obtained from the Prefectura's National Secretariat of Natural Resources (Ex-Cordecruz), including land use capacity and soil cartography. Wetlands will be delineated by vegetation type and soil classification.

### 3.1 EROSION AND SEDIMENT CONTROL

The Project's objective is to minimize the potential for erosion and sedimentation during pipeline construction, and to effectively restore the ROW and other disturbed areas. The erosion and sediment control measures contained in this section will serve as minimum standards to be used during construction. In general, the measures are designed to minimize erosion and sedimentation by:

## *ENVIRONMENTAL MANAGEMENT PLAN*

1. Minimizing the quantity and duration of soil exposure;
2. Protecting critical areas during construction by reducing the velocity of water and redirecting runoff;
3. Installing and maintaining erosion and sediment control measures during construction;
4. Establishing vegetation as soon as possible following final grading; and
5. Inspecting the ROW and maintaining erosion and sediment controls as necessary until final stabilization is achieved.

This section includes erosion and sediment control techniques that apply to all areas of construction; and expands on the clearing, grading, ditching, lowering-in/backfilling and restoration phases of construction to describe how these operations will be controlled to minimize potential impacts from construction. This section also discusses the use of safety precautions during construction.

### **3.2 CLEARING**

#### **3.2.1 Standard Procedures**

Clearing involves the removal of trees, brush and other vegetation from the ROW. The following are standard procedures to be followed during clearing:

1. ROW boundaries (e.g., limits of work) will be clearly delineated and the Inspector will ensure that no clearing occurs beyond the boundaries.
2. Trees to be saved shall be marked by flagging, fencing, or some other method before clearing begins.
3. Stemmed vegetation such as brush, shrubs and trees shall be removed at or near the ground level, leaving the root systems intact to the greatest extent practical.

All fences whether they be for livestock or security shall be maintained by the use of a temporary fence section (gap). Prior to the fence being cut, the fence will be properly braced and similar material used to construct the gap. At no time will an opening be left unattended. The gap will be replaced after cleanup with a permanent fence of the same material and in a like condition as was prior to the construction.

When pruning is necessary to clear the ROW, pruning cuts shall be made as follows:

- a. Cuts should be smooth;
- b. Branch collars shall not be cut (i.e., cuts should be made immediately in front of the branch collar);
- c. Large, heavy branches shall be precut on the underside to prevent splitting or peeling of bark; and
- d. Climbing spurs shall not be used, as they will damage the bark.
- e. Trees shall be felled into the ROW.
- f. Any trees which have fallen into waterbodies or beyond the edge of the ROW shall be removed immediately.
- g. Trees located outside of the ROW will not be cut to obtain timber for use elsewhere along the ROW.

### **3.2.2 Useable Timber**

Timber not specifically designated for other uses will be left in tree lengths and stacked along the edge of the ROW, used for rip-rap or to control erosion. Rip-rap must be removed from the ROW after construction is complete.

Timber shall not be stacked in drainage ways or left within wetlands unless site specific conditions warrant and procedures are approved by the Chief Environmental Inspector.

### **3.2.3 Trees and Brush Disposal**

Removed trees and brush shall be disposed of in one of the following ways depending on local restrictions, applicable license stipulations and as approved by the Chief Environmental Inspector:

- **Brush Piles**

- a. Brush shall be piled along the edge of the ROW to provide filter strips, wildlife habitat, or sediment barriers.
- b. In agricultural areas, any toxic vegetation shall be removed and shall not be stockpiled in areas available to livestock.
- c. All brush will be removed from wetland areas.

- **Chipping**

Slash and brush will be chipped or burned. Chips can be left on the ROW, in a manner that does not inhibit revegetation.

- **Burying**

Cleared materials may not be buried in wetlands, agricultural lands or residential areas. Stumps removed on the ROW will be buried.

- **Burning**

Burning of brush is permitted unless specifically prohibited in an area. Appropriate precautions must be exercised to prevent wild fires in the surrounding areas.

- **Off Site Disposal**

- a. Shall be done only when brush piles, chipping or burying are not permitted.
- b. An attempt should be made to find a market for any useable materials.
- c. Woody materials should be restricted to the edge of the ROW .

### 3.3 GRADING

When existing topography does not permit equipment to operate safely and does not provide access or an efficient work area, grading shall be required. Sharp topographic irregularities shall be graded to ensure rapid and safe passage of the work crews and equipment. Rock outcrops, ridges,

boulders and tree stumps shall be removed from the work area. Grading shall be performed by dozers equipped with ripper and grading blades. The following general construction methods will be employed during grading:

### **3.3.1 Removal of Tree Stumps**

Tree stumps are normally removed along the entire width of the ROW to allow adequate clearance for the safe operation of vehicles and equipment.

### **3.3.2 Disposal of Tree Stumps**

Tree stumps shall be disposed of by one of the following methods, pending approval of the landowner and in accordance with regulatory requirements:

1. Stumps may be buried (evenly distributed) along the ROW (except in wetlands and cultivated agricultural lands) in accordance with license or permit conditions.
2. Stumps may be removed from the site and disposed of in an approved site.
3. Stumps may be chipped in upland areas.
4. Stumps may be burned.

### **3.3.3 Rock Disposal**

Rock (including blast rock) shall be used or disposed in one or more of the following ways:

1. Buried on the ROW. Rock can only be buried to the original rock horizon in wetlands, agricultural lands and residential areas.
2. Left on the ROW in a density and pattern similar to the surrounding terrain, or windrowed with the landowner's permission.
3. Used to stabilize side hill cuts and cross ROW drainage areas.
4. Removed and hauled away.



5. Used as rip-rap for stream bank stabilization where available and warranted by field conditions and approved by the Environmental Inspector.
6. Used to construct stonewalls or stone fences.

### 3.3.4 Water Bars/Terraces (Slope Breakers)

1. Water bars/terraces shall be installed diagonally across the ROW on slopes to control erosion by reducing and shortening the length and concentration of runoff.
2. Soil will be slightly excavated and compacted to form a temporary channel with an adjacent downslope berm or ridge of compacted soil.
3. The degree of slope, soil characteristics, runoff area and location of suitable outlets determines the number and shape of water bars required; however, the minimum guidelines for spacing are as follows:

<u>Slope %</u>	<u>Spacing</u>
5 - 15	100 meters apart
16 - 30	65 meters apart
> 30	30 meters apart

4. The bar/terrace shall be broad and gradual to permit traffic to move over it safely without easily destroying it.
5. Water bars/terraces shall be maintained and repaired as necessary during construction.
6. Water bars/terraces shall divert water to a well-vegetated area. If a vegetated area is not available, erosion control barriers shall be installed to filter the runoff at the outlet of the water bar and off of the construction ROW.
7. Filter fabric fences or brush piles may be used in place of water bars/terraces at the discretion of the Environmental Inspector.

### **3.3.5 Erosion Control Barriers/Structures**

Erosion control barriers/structures consist of filter fabric fences, brush piles or rock rip-rap. Erosion control barriers/structures are required, as described below.

1. At the outlet of a water bar when vegetation is not adequate to control erosion.
2. Along banks of waterbodies between the graded ROW and waterbody after clearing.
3. Downslope of any stockpiled soil in the immediate vicinity of waterbodies and wetlands.
4. At the base of slopes adjacent to road crossings where vegetation has been disturbed
5. To be maintained throughout construction and shall remain in place until permanent revegetation measures have been judged successful.
6. To be inspected periodically to ensure its proper functioning, and as soon as possible following a significant rainfall, throughout construction.

### **3.3.6 Filter Fabric Fence Installation (Figure 2)**

1. Filter fabric fences shall be imbedded a minimum of approximately 10 centimeters or anchored as site conditions require.
2. The fence shall be installed in compliance with manufacturer's specifications.
3. Accumulated sediment shall be removed regularly and the fence inspected to ensure that the bottom of fence remains imbedded in ground.
4. A sufficient stockpile of silt fence shall be maintained on site for emergency use.

## **3.4 DITCHING**

### **3.4.1 Topsoil Segregation**

Topsoil is required to be segregated in most wetlands and cultivated agricultural lands. Topsoil is segregated as part of the ditching procedure for wetlands. In agricultural lands topsoil is segregated prior to ditching (see Section 4.10).

1. Topsoil and subsoil will be segregated during ditching and stockpiled separately.
2. Topsoil should be removed to its actual depth or to a maximum depth of 30 centimeters, as determined by the Environmental Inspector.
3. Topsoil shall not be used for padding, backfill or trench breakers, under any circumstances.
4. Topsoil stripping shall be accomplished as follows:
  - a) Cultivated Agricultural areas - Topsoil should be stripped over ditch line.
  - b) Wetland areas - Topsoil must be stripped over ditch line only.
  - c) Forest and other areas - Topsoil stripping is not required.
  - d) Aeolic Plain area - Topsoil will be stripped over the ditch line.

#### 3.4.2 Underground Utilities

1. Shall be located and carefully exposed.
2. Appropriate authorities must be notified.

#### 3.4.3 Temporary Ditch Plugs

Ditch plugs are portions of the ditch which break the continuous open trench. Soft plugs consist of compacted subsoil or sandbags placed across the ditch following excavation. Hard plugs consist of unexcavated portions of the ditch.

On steep slopes, plugs serve to reduce erosion and sedimentation in the trenchline and thus minimize dewatering problems at the base of the slope where sensitive environments, such as waterbodies and wetlands, are frequently located. Plugs adjacent to wetlands and waterbodies prevent diversion of water into upland portions of the pipeline trench during construction. In addition, plugs provide access across the ditch for wildlife and livestock. The following guidelines will apply to trench plugs:

1. To guard against failure, soft plugs constructed to hold water will be longer, along the trenchline, than they are tall, constructed of compacted layers, and inspected regularly by the Contractor to prevent breaching.

2. Installation of plugs will be coordinated with installation of temporary water bars in order to more effectively divert water off the ROW.
3. Topsoil will not be used for plugs.
4. When removing plugs located above waterbodies or wetlands, water accumulated behind the plugs will be pumped out onto a well-vegetated area or filtered before the plug is removed (see trench dewatering Section 3.5 of this EMP).

### **3.5 LOWERING-IN/BACKFILLING**

During lowering-in and backfilling, the following standard techniques will be used:

#### **3.5.1 Trench Dewatering**

Removal of collected water from the trench is one of the potential sources of siltation and erosion during pipeline construction. To minimize the risk, the following procedures should be followed:

The intakes of the hoses used to withdraw the water from the ditch will be elevated above the bottom of the trench to minimize pumping the deposited sediments.

1. Intake of the hoses used to withdraw the water will be screened.
2. The discharge shall be equipped with a device to dissipate the velocity to prevent erosion and scouring.
3. The locations of all areas which are to receive water discharged from trenches will be approved by the Environmental Inspector. The discharged water will be filtered by one of the following methods:
  - a. if greater than approximately 30 meters from a wetland or stream bank, the discharge should be directed into a well vegetated area; or
  - b. if no well vegetated area is available or the discharge point is less than approximately 30 meters from a wetland or stream bank, then the discharge should will be directed through a filter bag and/or into areas contained by erosion control barriers.

Under no circumstances will trench water or other forms of turbid water be directly discharged onto exposed soil or into any wetland or waterbody.

### **3.5.2 Padding**

1. Used where specified so that rock, gravel or other materials will not damage the pipe coating.
2. Consists of a layer of rock-free (less than approximately 4 centimeters in dimension) subsoil or sand placed around the pipe.
3. Under no circumstances will topsoil be used as padding.
4. May need to be hauled to the site from an approved borrow site. Topsoil from borrow site will be stripped prior to excavation of padding material. All borrow sites will be restored following construction.
5. Rocks up to 15 centimeters in dimension may be placed adjacent to the pipeline where specified rock shield is used to protect the pipe.

### **3.5.3 Trench Breakers (Figure 3)**

1. Installed in ditch as a permanent measure prior to backfilling.
2. Constructed on sloping terrain to control runoff from channeling along the buried pipeline.
3. Consists of sandbags, earth-filled sacks or other approved materials.
4. Topsoil shall not be used to fill the sacks.
5. Must be a minimum of two sacks wide and should be embedded in the sides of the ditch to create a seal.
6. Installed on slopes, as required, including the base of slopes, adjacent to waterbodies and/or wetlands and in agricultural fields and residential areas.

7. Installed at the same spacing as permanent water bars unless otherwise determined necessary.

#### **3.5.4 Backfilling**

1. Subsoil shall be placed directly onto the padding material.
2. Excavated and blast rock may be used as backfill above the layer of padding in agricultural, wetland, and residential areas, up to the level of bedrock. Size and quantity of stones in the top 30 centimeters of subsoil backfill in agricultural lands shall be consistent with undisturbed soils adjacent to the right-of-way.
3. Heavy equipment may be used to compact the backfilled ditch to minimize settling, or else a crown of soil will be put over the pipeline to compensate for any future soil settling which may occur. Openings shall be left in the trenchline crown to allow for lateral surface drainage.
4. Excess or unsuitable material shall be disposed of in accordance with applicable regulations.

#### **3.5.5 Use or Disposal of Blast Rock**

1. Excess blast rock may be used as rock walls to prevent unauthorized access to the ROW or windrowed, as approved by the Chief Inspector and in accordance with landowner agreements and license requirements.
2. Blast rock which cannot be used shall be removed from the ROW and disposed of at an approved location or buried along the ROW at locations approved by the Chief Environmental Inspector.

### **3.6 HYDROSTATIC TESTING**

Hydrostatic testing verifies the integrity of pipeline segments. Integrity is tested by capping pipeline segments with test manifolds and filling the capped segments with water. The water is then pressurized and held for approximately eight hours (four hours for pretested fabricated units and short, visible sections). Any significant loss of pressure indicates that a leak may have

## *ENVIRONMENTAL MANAGEMENT PLAN*

occurred. The source of the water used for testing is typically local streams and rivers. Once the pipe is installed, hydrostatic testing will be performed in one or more segments.

The potential for environmental impacts from withdrawal and discharge of test water shall be minimized by utilizing the following procedures:

1. Pipeline sections will be hydrotested before installation under major waterbodies.
2. Hydrostatic test manifolds shall be located outside of wetlands and riparian areas to the maximum extent practicable.
3. Withdrawal from and discharge to all water sources will consider the protection of fisheries resources on a case-by-case basis.
4. Fill and spill activities will be in compliance with any license or permit requirements.
5. The intake shall be screened to avoid entrainment of fish.
6. Adequate flow rates will be maintained to protect aquatic life, provide for all waterbody uses, and provide for downstream withdrawals of water by existing users.
7. The discharge pipe shall be secured in place.
8. Test water shall be discharged either to a suitable receiving body of water, across a well-vegetated area or filtered through a filter bag or erosion control barriers. Water quality standards must be maintained.
9. Water discharge into water bodies and cultivated lands will be avoided where possible.
10. Test water shall be discharged against a splash plate or other dispersive device in order to aerate, slow and disperse the flow.
11. The rate of discharge shall be controlled in order to prevent flooding or erosion.
12. The Environmental Inspector will take samples of the fill and discharge waters, and the receiving waters before and after discharge, to ensure compliance with applicable water quality standards.

13. The Environmental Inspector will coordinate all hydrostatic test water withdrawal and discharge activities with the Chief Environmental Inspector.

### 3.7 RESTORATION AND REVEGETATION

Restoration and revegetation of the pipeline ROW includes permanent erosion and sediment control measures. However, in the event that final restoration cannot occur immediately, temporary erosion and sediment control measures will be employed until the weather is suitable for final cleanup. This section covers restoration and revegetation procedures for upland areas. Procedures for agricultural areas, wetlands and waterbodies are contained in Section 4.10.3, Section 4.11.2 and Section 4.12.2 of this EMP, respectively.

#### 3.7.1 Temporary Erosion Control

1. Initiate stabilization measures as soon as practicable on those portions of the ROW where activities have temporarily or permanently ceased.
2. In the event that construction is completed well in advance of the seeding season for perennial vegetation, all areas adjacent to waterbodies shall be mulched on either side of the waterbody, as directed by the Environmental Inspector.
3. Fertilize temporary plantings in accordance with the recommendations of soil conservation consultants.

#### 3.7.2 Permanent Restoration Measures

Permanent restoration and revegetation measures serve to control erosion and sedimentation by establishing a vegetative cover which protects the soil, and by using mechanical structures which can divert or slow runoff and trap sediment.

1. Final grading shall be completed as soon as practical after the ditch is backfilled, weather permitting, except as approved by the Environmental Inspector.
2. Rock which cannot be windrowed, buried, or exceeds that of the surrounding terrain shall be removed or used for ROW stabilization as specified by the Environmental Inspector.



3. All construction debris shall be removed from the ROW, and the ROW shall be graded to restore the original contour as much as possible.
4. Where trench compaction has not been done, the ROW shall be graded to pre-construction contours, as practical, with a small crown of soil left over the ditch to compensate for settling, but not to interfere with natural drainage.
5. Where topsoil has been segregated, the topsoil shall be spread back along the ditch line in an even layer.
6. All fences which were cut and replaced by gaps during construction shall be repaired to at minimum the equivalent preconstruction conditions.

### **3.7.3 Permanent Water Bars (Figure 4)**

1. Permanent water bars/terraces shall be constructed after final grading and prior to seeding according to the revegetation plan.
2. Where adjacent area is sloped, permanent water bars will be constructed to replace temporary erosion control barriers at road, waterbody and wetland crossings.
3. Soil will be slightly excavated and compacted to form a channel with an adjacent downslope berm or ridge of compacted soil.
4. The berm shall be broad and gradual to permit traffic to move over it safely without easily destroying it.

### **3.7.4 Contour Wattling (Figure 5)**

1. The ideal plant materials for wattling are those that: (1) root easily; (2) are long, straight, and flexible; and (3) are in plentiful supply near the job site.
2. Wattling bundles should be cigar shaped, approximately 20-25 cm in diameter, a minimum of 1 meter in length, and placed in shallow trenches dug perpendicular to the slope.
3. Stakes should be placed on downslope of trenches in a manner which anchors the bundles to the slope.

### 3.7.5 Revegetation and Seeding

1. The ROW will be seeded and fertilized in the sandy Aeolic plain near the San Miguel River with appropriate seed mixes and seeding dates.
2. Slopes steeper than 3:1 shall be seeded immediately after final grading in accordance with recommended procedures and seeding dates, weather permitting.
3. The seed shall be applied uniformly over the area and covered approximately 1 to 2.5 centimeters deep, depending on seed size. A seed drill equipped with a cultipacker (rastra) is preferred, but broadcast or hydro-seeding can be used at double the recommended seeding rates. Where broadcast seeding is used, the seedbed shall be firmed with a cultipacker or roller after seeding.
4. Where broadcast or hydro-seeding is to be done, the seedbed will be scarified to ensure sites for seeds to lodge and germinate.
5. Where hand broadcast seeding is used, the seed shall be applied at one-half the rate in each of two separate passes. The passes will be made perpendicular to each other to ensure complete and uniform coverage.
6. The seedbed will be prepared using appropriate equipment to provide a firm, smooth seedbed.
7. If seeding cannot be done within the recommended seeding dates, temporary erosion and sediment controls shall be used and seeding of permanent cover shall be done at the beginning of the next seeding season.
8. Other alternative seed mixes specifically requested by the landowner or land-managing agency may be used.

### 3.7.6 Mulching

Mulching assists in controlling erosion by: decreasing the impact of rainfall on soil surface; reducing runoff; holding seed, lime and fertilizer in place; reducing loss of soil moisture by evaporation; and moderating soil temperature. Mulching should be used as needed to assist in controlling erosion and assisting in establishing revegetative cover.

Mulch should not be used in wetlands, on lawns, in agricultural (crop) areas, and areas where hydro-mulch is used. In steep slopes, mulch may be anchored with a netting made of jute or similar materials (Figure 6).

### **3.8 SAFETY**

1. Temporary safety fences shall be erected at ROW crossings where necessary, to maintain a safe workplace.
2. The length of time the ditch is left open shall be minimized as much as practical.
3. Unauthorized vehicular use shall be prevented on the access roads.

### **3.9 ACCESS ROADS**

1. Access roads may require side ditches and water bars or terraces to provide drainage. If side ditches are required, they shall be excavated parallel to the road in such a way to channel runoff away from the road.
2. The access roads will be restored to pre-construction conditions or better unless specified by the landowner.
3. If subsoils are unstable, corduroy paths (log, rip-rap or timber matting) may be needed. These materials will be removed during clean-up.
4. Only approved access roads will be used.

### **4.0 SPECIALIZED CONSTRUCTION**

Specialized construction techniques will be used in certain areas along the pipeline route. Specialized construction methods will be used only as required. These methods are described below.

#### 4.1 BLASTING

Installing the pipe may require blasting in some areas, such as those with rock outcrops. During blasting, contractors will take precautions to minimize damage to adjacent areas and structures. These precautions include:

1. Installing blasting mats in congested areas, in shallow waterbodies, or near structures that could be damaged by fly-rock;
2. posting warning signals, flags, and barricades;
3. following procedures for safe storage, handling, loading, firing, and disposal of explosive materials in accordance with country regulations; and
4. manning adjacent pipelines at valves for emergency response.

Blasting standards will meet or exceed all applicable governmental requirements covering the use of explosives. Excessive vibration can be controlled by limiting the size of charges and by using charge delays, which stagger each charge in a series of explosions.

If the Contractor has to blast near buildings, a qualified independent contractor will inspect potentially affected structures prior to blasting, either at the pipeline contractor's request or at the request of the affected landowner. Post-blast inspections by the company's representative will also be performed as warranted. All blasting will be performed by registered blasters. During blasting, the Contractor will monitor ground vibrations at the nearest structure (or well) that is within 60 meters of the blast site, or in accordance with regulations.

If the Contractor has to blast near wells, all wells in potentially affected areas will be inventoried prior to construction. In addition, all wells will be inspected both before and after blasting.

Where blasting occurs in wetlands, topsoil along the ditchline will be segregated prior to blasting. Rock removed from the trench will be stored with subsoil material. In order to limit the equipment operating in wetlands and avoid the need to import replacement fill, rock will not be removed from the wetland but will be returned to the trench as subsoil. Surface rock should not exceed pre-construction conditions as directed by the Environmental Inspector.

## 4.2 THE TWO-TONE APPROACH

When working in areas with homogeneous topography, the surface of the working side of the ROW is usually leveled at a grade equal to the elevation of the top of the ditch. This facilitates the safe passage of equipment and installation of the pipe. Where the pipeline crosses rugged topography, however, such as steep side slopes, contractors often construct the working side of the ROW such that it has two levels, or tones, that parallel the ditch. The tone closest to the ditch is used for construction, while the tone farthest from the ditch is used for travel. The height of the construction tone is usually as close to the height of the ditch as possible. The elevation of the travel tone will be higher or lower than the height of the construction tone, depending on the area's natural grade. The two-tone approach reduces the amount of dirt and rock that must be moved.

## 4.3 DRAG SECTIONS

Drag sections are used when trying to reduce the space necessary to work in a given location. Drag sections are multiple joint sections of pipe which have been pre-assembled (bent, welded, x-rayed, coated, etc.) in a staging area near, but not adjacent to, the ditch where it will eventually be placed.

Drag sections are used for road crossings, waterbody and wetland crossings, residential areas and other locations. This technique is used when there is insufficient room to assemble the pipe in place or where the obstruction of having the pipe sitting along the ditch for a long period of time, such as a road crossing, is unacceptable. This technique is limited to a length of several joints which, can be picked up and carried (it is not dragged) as one piece into place by the available equipment.

## 4.4 STOVEPIPE

Stovepipe construction is often used in congested areas where there is extremely limited work space. This method entails welding together sections of pipe, lowering-in and immediately backfilling the ditch. Simultaneously, the pipeline ditch ahead is being excavated. Only tie-in points will be left excavated during non-working hours and will be fenced and secured.

Stovepipe construction can significantly reduce the amount of land disturbed while reducing the length of time the ditch is left open. However, this method typically progresses more slowly than normal construction methods.

#### **4.5 RESIDENTIAL AREA CONSTRUCTION**

The care exercised by construction crews and the quality of cleanup following construction are paramount concerns of homeowners. The Contractor will make every effort to ensure that all construction activities minimize any adverse impacts to residences and that cleanup is quick and thorough.

Throughout construction, access to homes will be maintained except for the brief periods essential for laying the new pipeline. Temporary safety fences may be erected by the Contractor in the vicinity of streets and homes to keep the public away from the construction zone. Techniques such as stovepipe and drag section construction may be used in order to minimize the impacts of construction in residential areas on a site-specific basis.

Homeowners will be notified in advance of any scheduled disruption of household utilities, and the duration of the interruption will be kept as brief as possible. Representatives of local utility companies will be on-site during construction when necessary. In addition, the Contractor should strive to accommodate any special concerns regarding shrubs, trees, or structures by avoiding them, as long as such avoidances will not unduly interfere with construction and operation of the pipeline.

Immediately after backfilling, residential areas will be cleaned up and all construction debris will be removed.

#### **4.6 BORING**

Boring entails drilling a hole below travel arteries, such as highways and railroads through which the pipe will pass. This method may be used in sensitive areas where the artery cannot be crossed by conventional open cut methods. Tunneling may be acceptable in some areas.

#### **4.7 JACKING**

Jacking is similar to boring except that an open-ended casing is forced, or jacked through the earth below the artery. Soils are then removed from the casing. The remainder of the installation procedure is identical to that described for boring.

#### 4.8 DIRECTIONAL DRILLING

Directional drilling requires the drilling of a small diameter hole, or pilot hole, along a predetermined design path. The pilot hole is then enlarged sufficiently to accommodate the pipeline to be installed. The pipeline may or may not be installed concurrently with the hole enlargement depending upon the final diameter of the enlarged hole and the soil conditions encountered. The following conditions also apply to directional drilling:

1. Excavation of the drill entry and exit locations will be necessary to contain drilling fluids during all phases of the installation. These fluids and cuttings must be disposed of in an approved manner periodically or at the completion of the crossing installation.
2. The crossing length and cross sectional geometry is dependent upon the pipeline design parameters, the obstacle to be crossed, and the subsurface conditions.
3. Additional temporary work space, including pipe staging areas and storage areas for drilling mud and borehole cuttings, will be located in upland areas outside of wetlands and riparian zones wherever practicable.

This method requires a large amount of additional temporary work space and is only used in areas where boring and conventional open cut methods are not suitable.

#### 4.9 EQUIPMENT CROSSOVERS

In an equipment crossover, the working side of the ROW is temporarily shifted to the other side of the ROW. Equipment crossovers are used to reduce impacts to sensitive areas such as residential, wetlands, and archaeological sites.

The use of equipment crossovers will be reserved for extreme circumstances because of the requirements for the construction equipment to work backwards.

#### 4.10 AGRICULTURAL AREA CONSTRUCTION (Figure 7)

Agricultural areas include crops, orchards, and vineyards. Prior to construction, landowners will be contacted to locate any existing and determine future locations of drainage tiles and irrigation systems. Water flow in crop irrigation systems will be maintained unless shutoff is coordinated with the affected parties.

Wetlands and waterbodies in agricultural areas shall be crossed as specified in Section 4.11 and Section 4.12 of this EMP, respectively.

At a minimum, the following measures will be adopted in actively farmed areas affected by project construction:

#### **4.10.1 Grading**

1. Prior to grading, the Environmental Inspector will determine the depth of topsoil to be stripped and segregated and enter the information into a field book for future reference. The depth to which the topsoil will be stripped will be to its actual depth or to a maximum depth of approximately 30 centimeters.
2. Natural flow patterns of fields will be maintained by providing breaks in topsoil and subsoil stockpiles.
3. In all actively cultivated agricultural lands, which includes permanent or rotated cropland, hayfields, or improved pastures, topsoil stripping over the ditch line shall be used. Additional temporary work space will be used for topsoil storage in agricultural areas.

#### **4.10.2 Ditching\Lowering\Backfilling**

1. It is necessary to maintain flow in the drainage system during construction.
2. All drainage systems shall be probed to determine if damage has occurred. All tiles damaged during construction shall be flagged by the trench inspector, then repaired to its original or better condition.
3. Records of drainage system repairs shall be kept and given to the landowner for future reference upon request.

#### **4.10.3 Restoration and Revegetation**

1. Final grading shall be completed as soon as possible after the ditch is backfilled, weather permitting.



2. Construction debris shall be removed from the ROW.
3. Any rutting or compaction shall be repaired prior to revegetating disturbed areas.
4. The ROW shall be graded to pre-construction contours, except where original contours were irregular and more uniform contours may be acceptable.
5. Subsoil compaction shall be relieved using a harrow, paraplow, paratill or other equipment. All stones greater than those in adjacent undisturbed soils which are brought to the surface during the decompaction process shall be removed. Decompaction activities shall be conducted only during periods of relatively low soil moisture to ensure the desired mitigation and prevent additional subsurface compaction. The subsoil shall be decompacted prior to replacement of the segregated topsoil.
6. Topsoil shall be replaced last. Soils shall be crowned along the ditchline to allow for settling, unless otherwise directed by the Chief Environmental Inspector. Openings shall be left in the ditch line crown to allow lateral surface drainage.
7. Size and quantity of stones in the top 30 centimeters of subsoil backfill in agricultural lands shall be consistent with undisturbed soils adjacent to the right-of-way.

#### **4.11 WETLAND CROSSINGS**

##### **4.11.1 General Measures**

Potential adverse impacts to wetlands will be minimized by:

1. Expediting construction in and around wetlands, and limiting the amount of equipment and mainline construction activities within wetlands to reduce disturbances of wetland soils;
2. Restoring wetlands to their original configurations and contours;
3. Stabilizing upland areas near wetlands as required to prevent erosion using control measures and vegetative cover as soon as possible after backfilling; and
4. Inspecting the ROW periodically during and after construction, and repairing any erosion control or restoration features as needed in a timely manner.

#### **4.11.2 Additional Work Space Areas**

The size of staging areas at wetland crossings will be limited to the space necessary for fabricating only those pipe segments required for the crossing. Other additional work spaces, such as additional spoil storage areas, at wetland crossings will also be limited to the size necessary to perform their function. All additional work space areas will be located at least 10 meters from the edge of the wetland where topographic conditions permit. The wetlands and setbacks will be clearly marked prior to the start of construction.

To avoid contaminants entering the wetland, the Contractor will follow the spill prevention measures described in Section 5.0 of this EMP. Hazardous materials, chemicals, fuels or lubricating oils will not be stored nor will concrete coating activities (excluding field joints) be performed within 15 meters of any water body. If field joints are concrete coated within 15 meters of a wetland, protective ground coverings will be used in the area of the coating operation. In addition, construction equipment will typically not be refueled or serviced within 15 meters of all wetlands. If the equipment cannot be reasonably moved 15 meters or more away from the wetland without unnecessarily harming the environment, or the equipment being fueled or serviced is mounted on a barge, Contractors will complete such activities in accordance with the measures specified in Section 5.0 of this EMP and supervised by on-site Environmental Inspectors.

#### **4.11.3 Spoil Pile Placement/Control**

Spoil placed up-gradient of wetlands will be contained with sediment control devices as necessary to prevent spoil materials from flowing into wetlands or off of the ROW.

#### **4.11.4 Wetland Crossing Procedures**

Unless a site-specific method is recommended, one of the following four methods will be used for crossing wetlands during construction. The four wetland crossing methods are:

- Method I: Standard Pipeline Construction Method
- Method II: Conventional Wetland Construction Method
- Method III: Push/Pull Wetland Construction Method
- Method IV: Other (Site-Specific concerns)

This section discusses Methods I, II and III which are based on standard wetland pipeline construction practices. The proposed method of crossing each wetland will be determined in the field based on the site conditions found in the field at the time of construction.

#### **4.11.4.1 Method I: Standard Pipeline Construction**

The Standard Pipeline Construction, Wetland Method I, can be used in wetlands where soils are dry enough at the time of construction to support equipment. Thus, this method is typically used when rainfall is at a minimum and the water table is lowest. This crossing method requires the segregation of topsoil from subsoil.

Specific mitigative measures which will be employed when using this method are as follows.

##### **Clearing**

1. This method requires no special stabilization techniques because conditions can support construction equipment.
2. No equipment with rubber tires will be allowed to work in wetlands unless the equipment will not damage existing root systems and its use is approved by the Chief Environmental Inspector. Hydroaxe and bulldozers will be used to remove timber, trees or brush.
3. All timber and brush will be removed from the wetland.
4. Debris and stumps will not be buried within wetlands, but may be buried in the ROW outside of wetlands.
5. Contractors will not cut trees located outside of the ROW.
6. The Environmental Inspector will photo document areas before and after clearing for use in later revegetation/restoration.

##### **Grading**

1. Extensive grading will normally be unnecessary because the topography of most wetlands is level. Grading will be limited to the areas directly over the trenchline, except where topography, such as side slopes, requires additional grading for safety reasons. Where grading is required, topsoil will be segregated and returned as an even layer to all graded areas.
2. Grading along waterbodies within wetlands will be done according to requirements specified in Section 4.12.

**Trenching**

1. The wetland topsoil, to a depth determined by the Environmental Inspector up to a maximum of 30 centimeters, will be stripped from over the ditchline and stockpiled separately from subsoil for later restoration of the ROW.
2. Following segregation of the topsoil, the remainder of the ditch will be excavated so that the pipe will have a minimum of approximately 1 meter of cover unless otherwise specified.
3. Where rock has been removed from the ditch, it will be stored with subsoil material.
4. Spoil will be contained with filter fabric fences or other sediment barriers to prevent the spoil from flowing off of the ROW or into waterbodies.

**Lowering-in\Backfilling**

1. The trench will be backfilled with subsoil first. After the subsoil has been rough graded, topsoil will be replaced in an even layer. The topsoil contains seeds, rhizomes and other plant propagules which will aid rapid recolonization by indigenous wetland species.
2. Because wetland soils are generally soft, and the pipe is concrete coated to provide negative buoyancy, pipeline padding is usually unnecessary.
3. The trench will be dewatered as needed and in accordance with erosion and sediment control specifications detailed in Section 3.5.
4. Any additional spoil material imported from off the ROW must be approved by the Environmental Inspector.
5. In order to limit the equipment operating in wetlands and avoid the need to import replacement fill, rock excavated from the trench will not be removed from the wetland but will be returned to the trench with the subsoil.
6. Where rock (boulders, etc) was part of the surface features prior to construction of the pipeline, rock will be placed back in the wetland in approximately the same configuration as had been the pre-construction situation.

7. Permanent trench plugs shall be installed at both ends of the wetland where drainage of the wetland along the pipeline trench may occur.

#### **Cleanup/Restoration**

1. All work mats, timber rip-rap and other construction debris shall be removed following backfilling of the pipeline.
2. Once backfilling is complete, the affected areas will be restored to their original contours and flow regimes to the extent practicable, with the exceptions of unnatural features and unstable grades.

#### **4.11.4.2 Method II: Conventional Wetland Construction (Figure 8)**

Conventional Wetland Construction, Wetland Method II, will be used for crossing wetlands with saturated soils or soils otherwise unable to support mainline construction equipment. Because the soils are saturated, there is a need to stabilize the ROW during construction. Method II addresses this need for stabilization.

The following mitigation measures will be used when constructing by this method:

#### **Clearing**

1. The ROW will be stabilized by the use of: timber rip-rap (corduroy roads), fabricated timber mats or gravel over geotextile fabric.
2. Contractors will not use soil, rockfill, pulled tree stumps or slash rip-rap to stabilize the travel lane.
3. No equipment with rubber tires will be allowed to work in wetlands unless the equipment will not damage existing root systems and its use is approved by the Chief Environmental Inspector.
4. All timber and brush will be removed from the wetland.
5. Debris and stumps will not be buried within wetlands, but may be buried in the ROW outside of wetlands where permitted.
6. Contractors will not cut trees located outside of the ROW.

### Grading

1. Because of the construction constraints associated with saturated wetland soils, and because of the level nature of these wetlands, grading will most likely not be required. Should grading be necessary, it will be limited to the areas directly over the trenchline, except where topography requires additional grading for safety reasons. Where grading is required, topsoil will be segregated and returned as an even layer to all graded areas.
2. Grading along waterbodies within wetlands will be done according to requirements specified in Section 4.12.2.1 of this EMP.

### Trenching

1. The wetland topsoil, to a depth determined by the Environmental Inspector up to a maximum of 30 centimeters, will be stripped from over the ditchline and stockpiled separately from subsoil removed during trenching except where standing water is present.
2. Following segregation of the topsoil, the remainder of the ditch will be excavated so that the pipe will have a minimum of 1 meter of cover unless otherwise specified.
3. Where rock has been removed from the ditch, it will be stored with subsoil material.
4. Spoil will be contained with filter fabric fences or other sediment barriers to prevent the spoil from flowing off of the ROW or into waterbodies.

### Lowering-in\Backfilling

1. The trench will be backfilled with subsoil first. After the subsoil has been rough graded, topsoil will be replaced in an even layer. The topsoil contains seeds, rhizomes and other plant propagules which will aid in the rapid recolonization by indigenous wetland species.
2. Because wetland soils are generally soft, and the pipe is concrete coated to provide negative buoyancy, pipeline padding is usually unnecessary.
3. The trench will be dewatered as needed and in accordance with erosion and sediment control specifications detailed in Section 3.5.
4. Any additional spoil material imported from off the ROW must be approved by the Environmental Inspector.

5. In order to limit the equipment operating in wetlands and avoid the need to import replacement fill, rock excavated from the trench will not be removed from the wetland but will be returned to the trench as subsoil.
6. Where rock (boulders, etc) was part of the surface features prior to construction of the pipeline, rock will be placed back in the wetland in approximately the same configuration as had been the pre-construction situation.
7. Permanent trench plugs shall be installed at both ends of the wetland where drainage of the wetland along the pipeline trench may occur.

#### **Cleanup/Restoration**

1. All work mats, timber rip-rap, and other construction debris shall be removed following backfilling of the pipeline.
2. Once backfilling is complete, Contractors will restore the affected area's original contours and flow regimes to the extent practicable, with the exceptions of unnatural features and unstable grades.

#### **4.11.4.3 Method III: Push/Pull Wetland Construction (Figure 9)**

Push/Pull Wetland Construction, Wetland Method III, entails pushing or pulling a floating section of pre-assembled pipe into position over an inundated trench. The floats are removed and the concrete-coated pipe sinks into the trench. The section of pipeline to be floated into place must be straight or nearly straight to be able to float within the confines of the excavated ditch. This method should be used in large wetland areas where water levels are high enough at the time of construction to float the pipeline into the trench and where such levels can be maintained without damming.

Through the use of this crossing method, impacts to the wetland are minimized. The Push/Pull Method requires less clearing than Methods I and II because construction space is only required to allow the backhoe to traverse the wetland and to stockpile excavated soil. Although all equipment will be allowed to pass through wetlands as necessary, only equipment needed to clear, excavate, and backfill will be permitted to work in the wetland area. Also, because the pipe will be assembled outside the wetland, this technique will not require work space adjacent to the trench to operate sidebooms. Additional work space may be needed adjacent to the wetland boundaries for pipe fabrication.

The following impact minimization measures will be followed when using the Push/Pull Method of construction:

**Clearing**

1. Clearing within the wetland will be minimized. (The width cleared will be limited to only that necessary to install the pipeline.)
2. Trees and brush will be cleared using low ground pressure or pontoon mounted equipment, or with equipment supported by timber work mats.
3. No equipment with rubber tires will be allowed to work in wetlands.
4. All timber and brush will be removed from the wetland.
5. Debris and stumps will not be buried within wetlands, but may be buried in the ROW outside of wetlands where permitted.
6. Trees located outside of the ROW shall not be cut.
7. The Environmental Inspector will photo document areas before and after clearing.

**Grading**

1. Grading in inundated wetlands will be held to a minimum and generally will not be necessary due to the typically level topography and the absence of rock outcrops in such areas.

**Trenching**

1. Amphibious excavators (pontoon mounted backhoes) or tracked backhoes (supported by fabricated timber work mats or floats) will be used to dig trenches.
2. If fabricated timber work mats are used for stabilization, the backhoe will gradually move across the wetland by moving the mat from immediately behind to the front of the backhoe's path. This "leap frog" process minimizes impact to the wetland by distributing the weight of the backhoe, reducing the number of passes through the wetland, and minimizing the area covered by timber mats at any given time. Amphibious excavators and floats are self-supporting and do not require the use of timber mats.



3. The wetland topsoil, to a depth determined by the Environmental Inspector up to a maximum of 30 centimeters, will be stripped from over the ditchline and stockpiled separately from subsoil removed during trenching except in submerged areas unless determined by the Environmental Inspector that segregation is not feasible.
4. Following segregation of the topsoil, the remainder of the ditch will be excavated so that the pipe will have a minimum of approximately 1 meter of cover unless otherwise specified.
5. Where rock has been removed from the ditch, it will be stored with the subsoil material.

#### **Lowering-in**

1. Each pipeline section will be floated and pushed/pulled through the trench in the wetland. Once the appropriate location is reached, the floats will be released and the concrete-coated pipe will be allowed to sink to the bottom of the trench.

#### **Backfilling**

1. Backfilling (with backhoe or amphibious excavator) and obtaining final elevations will be done in one pass. Original excavated material will be used to backfill the trench.
2. Wherever topsoil and subsoil have been segregated, the trench will be backfilled with subsoil first. After the subsoil has been rough graded, topsoil will be replaced in an even layer. The topsoil contains seeds, rhizomes and other plant propagules which will aid in the rapid recolonization by indigenous wetland species.
3. Because wetland soils are generally soft, and the pipe is concrete coated to provide negative buoyancy, pipeline padding is usually unnecessary.
4. The trench will be dewatered as needed and in accordance with erosion and sediment control specifications detailed in Section 3.5.
5. Permanent trench plugs shall be installed at both ends of the wetland where drainage of the wetland along the pipeline trench may occur.

**Cleanup/Restoration**

1. All work mats, timber rip-rap, and other construction debris shall be removed following backfilling of the pipeline.
2. Once backfilling is complete, the affected area's original contours and flow regimes will be restored to the extent practicable, with the exceptions of unnatural features and unstable grades.

**4.12 WATERBODY CROSSINGS**

**4.12.1 General Measures**

Contractors shall protect and minimize potential adverse impacts to waterbodies by:

1. Expediting construction and limiting the amount of equipment and mainline construction activities within waterbodies to minimize disturbances to streambeds and adjacent soils, thereby minimizing the amount of suspended sediments attributable to the project;
2. Reducing clearing, leaving in place as many trees as possible on stream banks;
3. Constructing waterbody crossings as perpendicular to the axis of the waterbody channel as engineering and routing conditions allow;
4. Maintaining ambient downstream flow rates;
5. Removing all material and structures related to construction from each waterbody bed after construction;
6. Restoring stream channels and bottoms to their original configurations and contours;
7. Permanently stabilizing stream banks and adjacent upland areas using erosion control measures and vegetative cover as soon as possible after construction; and
8. Inspecting ROWs periodically during and after construction and repairing any erosion controls and/or performing restoration, as needed, in a timely manner.

#### **4.12.2 General Procedures**

The following general conditions apply to all waterbody crossings:

##### **Schedule**

Construction across waterbodies should be completed in the shortest amount of time possible to minimize the duration of potential adverse impacts. Installing pipe and backfilling of waterbody crossings should be completed in the shortest time possible unless site conditions prohibit the completion, or in the case that blasting is required. If site-specific physical conditions make these time restrictions impractical, then a site-specific plan should be developed.

##### **Additional Work Space Areas**

Construction staging areas for waterbody crossings will be as small as possible while still allowing for prefabrication of pipe segments that will cross the waterbody. Other additional work spaces, such as additional spoil storage areas, at waterbody crossings will also be limited to the size necessary to perform the required function. All additional work space areas will be located approximately 10 meters from the stream banks, where topographic conditions permit.

To minimize the potential for contaminants entering the waterbody, Contractors will follow the spill prevention measures described in Section 5.0. Hazardous materials, chemicals, fuels, or lubricating oils will not be stored nor will concrete coating activities be performed within 15 meters of stream banks. In addition, construction equipment will not be refueled or serviced within 15 meters of stream banks in most cases. If the equipment cannot be reasonably moved 15 or more meters away from the stream banks, without unnecessarily harming the environment, or the equipment being fueled or serviced is mounted on a barge, such activities will be performed according to spill prevention measures described in Section 5.0.

##### **Spoil Pile Placement/Control**

Trench spoil will be stored at least 3 meters back from stream banks at waterbody crossings, where possible. Spoil placed up-gradient of stream banks will be contained with sediment control devices to prevent spoil materials from flowing into waterbodies or off of the ROW.

### Equipment Crossings

Construction of equipment crossings, will occur during the clearing or grading process. Protective measures will include the use of timber mats laid adjacent to and across streambeds if banks are high enough, flume pipes covered by fill material or portable bridges approved by the Environmental Inspector. The size and number of the flume pipes will be sufficient for maximum anticipated flows.

If fill for equipment crossings includes soil or other material which could erode into the waterbody, sandbags will be used on both sides of the crossing. Sandbags will be placed in the waterbody, at the upstream and downstream ends of the crossing, to stabilize and seal any flume pipes used. To prevent erosion, sandbags will be placed high enough along both sides of the equipment crossing to contain the fill material during construction.

#### 4.12.3 Waterbody Crossing Procedures

The methods applied to waterbodies are:

**Method I: Wet Crossings**

- intermittent streams
- non-sensitive, perennial streams

**Method II: Other (Site-Specific Crossings)**

- waterbodies that can not be crossed by Method I or Method II
- rivers, ponds and lakes

This section discusses Method I which is based upon standard waterbody pipeline construction practices. The proposed method of crossing each waterbody will be determined in the field based on conditions found in the field at the time of construction.

##### 4.12.3.1 Method I: Wet Crossings (Figure 10)

#### Clearing/Grading

1. Clearing crews may cross waterbodies once, prior to installing equipment crossings. Clearing crews may construct temporary crossings by using timber mats or, occasionally, logs. Temporary crossings may not be used by grading or any subsequent crews; these crews will be responsible for constructing the long term equipment crossing.

2. The construction of the equipment crossing will use one of the following:
  - a. timber mats with or without flume(s), or
  - b. clean fill and flume(s), or
  - c. a Flexi-float or portable bridge.
3. Contractors will install flume pipes, as necessary, in the streambed for the equipment crossing in order to maintain the existing flow and course of the waterway. The size and number of the flume pipes will be sufficient for anticipated flows.
4. If it is likely that more than one week will pass between the time when the area is cleared and when the pipe is installed, the clearing crew may install sediment barriers at the top of the stream bank, if no vegetative strip is left.
5. Contractors will implement erosion and sedimentation controls, and bank stabilization procedures at all stream banks as described in Section 3.0.

#### **Trenching/Lowering-in/Backfilling**

1. If mainline ditching crews excavate waterbody crossings, ditching, lowering-in, backfilling, and restoration will be completed within the shortest time possible. If ditching, lowering-in, backfilling, and restoration of the waterbody crossing cannot be completed in a short time frame, a site specific work plan will be developed.
2. Where blasting is required, the banks of the waterbody are to be left intact (hard plugs). If soft plugs must be installed, then the pipe installation shall be completed as soon as possible upon completion of the blasting.
3. Contractors will use a backhoe or dragline to excavate the trench across the waterbody. Equipment used to dig the trench will work from the stream banks, equipment crossings, or by straddling the trenchline where the width of the waterbody prohibits excavations solely from the banks. The depth of trench will be sufficient to allow a minimum of 1 meter of cover over the pipeline below the streambed, unless otherwise specified.
4. Where necessary, the grade of the stream banks will be reduced to form a gradual slope and soil will be pushed or pulled away from the waterbody to minimize siltation.

### **Cleanup/Restoration**

1. Stream channels will be backfilled, re-contoured and restored immediately.
2. During restoration, flume pipes, sand bags and other material used for the waterbody crossing will be removed and the stream bottom and banks will be restored to their preconstruction contours or better to the extent practical.
3. Equipment crossings will be left in place if they are determined to be needed for access.
4. Jute thatching or other erosion control matting or material will be used to stabilize stream banks where necessary.

#### **4.12.3.2 Method II: Other (Site-Specific Crossings)**

Procedures for crossing rivers, ponds and lakes which cannot be crossed by Method I will be developed on a site specific basis.

### **4.13 COMBINED WETLAND/WATERBODY CROSSINGS**

Wetlands and waterbodies are commonly found together as one ecosystem. The crossing methods used will be based on field conditions to protect both resources equally. It is essential to recognize that individual construction methods will be assigned to both the wetland(s) and the waterbody(ies) to protect the resources. For complex systems, site-specific crossing methods will be designed.

## **5.0 SPILL PREVENTION AND CONTROL PLAN**

Contractors are responsible for implementing and maintaining spill control measures which address actions used to prevent spills and measures which should be taken should any spills occur.

### **5.1 PREVENTATIVE MEASURES**

#### **5.1.1 Training**

The Contractor will instruct construction personnel on the operation and maintenance of construction equipment to prevent the accidental discharge or spill of fuel, oil, and lubricants.

Personnel will also be made aware of the pollution control laws, rules, and regulations applicable to their work.

Spill prevention briefings with the construction crew will be scheduled and conducted by the Environmental Inspector at intervals frequent enough to assure adequate understanding of spill prevention measures. These briefings will highlight the following:

- precautionary measures to prevent spills;
- sources of spills, such as equipment failure or malfunction;
- standard operating procedures in case of a spill;
- equipment, materials, and supplies available for clean-up of a spill; and
- a list of known spill events.

#### **5.1.2 Equipment Inspection and Maintenance**

The Contractor will inspect and maintain equipment that must be fueled and/or lubricated according to a strict schedule. The Contractor will submit to the Environmental Inspector for approval written documentation of the methods used and work performed.

All containers, valves, pipelines, and hoses will be examined regularly to assess their general condition. The examination will identify any signs of deterioration that could cause a spill and signs of leaks, such as accumulated fluids. All leaks will be promptly corrected and/or repaired.

#### **5.1.3 Refueling**

##### **5.1.3.1 Refueling Operations**

The Contractor will assure that all equipment is refueled and lubricated within the ROW and at least 15 meters away from all waterbodies and wetlands with the following exceptions:

1. Areas such as rugged terrain or steep slopes where movement of equipment to refueling stations would cause excessive disturbance to the surface of the ROW;

2. Areas where removing equipment from a wetland for servicing would increase adverse impacts to the wetland;
3. Construction sites where moving equipment to refueling stations from pre-fabricated equipment pads is impracticable or where there is a natural barrier from the waterbody or wetland (i.e., road or railroad);
4. Locations where the waterbody or wetland is located adjacent to a road crossing (from which the equipment can be serviced);
5. Areas where flotation equipment will be used which will be refueled at designated docking locations; and
6. Refueling of immobile equipment including, but not limited to, bending and boring machines, air compressors, padding machines, and hydro-test fill pumps.

In these areas, auxiliary fuel tanks will be used to reduce the frequency of refueling operations and in no case will refueling take place within 30 meters of any known potable water wells.

#### **5.1.3.2 Conditions**

The Contractor will assure that all refueling be done pursuant to the following conditions:

1. Mitigation measures and equipment will be sufficient to prevent discharged fluids from leaving the ROW or reaching wetlands or waterbodies, and be readily available for use. These will include some combination of the following:
  - a. dikes, berms or retaining walls sufficiently impervious to contain spilled oil;
  - b. sorbent and barrier materials in quantities determined by the Contractor to be sufficient to capture the largest reasonably foreseeable spill;
  - c. disposable drums or containers suitable for holding and transporting contaminated materials;
  - d. curbing;
  - e. culverts, gutters, or other drainage systems;



- f. weirs, booms, or other barriers;
  - g. spill diversion or retention ponds; and
  - h. sumps and collection systems.
2. The Contractor will prepare a list of the type, quantity, and the storage location of containment and clean up equipment to be used during construction. The list will include the procedures and impact minimization measures to be used in case of a spill.
  3. The Contractor will prepare a pre-job, written inventory of lubricants, fuel, and other materials which could be accidentally discharged during construction.
  4. All spills will be cleaned up immediately. In no case will containment equipment be used for the storage of contaminated equipment.

#### **5.1.4 Storage**

Storage containment areas will not have drains, unless such drains lead to a containment area or vessel where the entire spill can be recovered.

## **5.2 MITIGATION MEASURES**

### **5.2.1 Containment**

Containment is the immediate priority in the case of a spill. A spill will be contained on the property or ROW if possible.

### **5.2.2 Clean up**

Clean up procedures will begin immediately after a spill is contained. In no case will containment equipment be used to store contaminated material. Equipment that will be used to facilitate cleanup and minimize damage to the environment is listed in Section 5.3.

### **5.2.3 Notification**

In case of a spill, the Contractor or utility inspector will notify the appropriate Environmental Inspector and construction supervisors.

### **5.2.4 Excavation and Disposal**

#### **5.2.4.1 Small Spills**

If the Environmental Inspector determines that a spill is small enough such that the construction crew can safely handle it, the crew will use construction equipment to containerize all spilled material, contaminated soil, and sorbent material in a manner consistent with the spilled materials' characterization.

#### **5.2.4.2 Large Spills**

If the Environmental Inspector determines that a spill cannot be adequately excavated and disposed of by the construction crew alone, the Contractor will follow procedures outlined in the Waste Management Plan.

### **5.2.5 Reporting**

The Contractor will prepare a Construction Site Spill Report form to be given to the Environmental Inspector that includes the following details of the incident:

1. the date, time and location of the occurrence;
2. a description of the material spilled;
3. the quantity spilled;
4. the circumstances that caused the spill;
5. a list of waterbodies affected or potentially affected by the spill;
6. a statement verifying whether a sheen is present;
7. the size of the affected area;
8. an estimate of the depth that the material has reached in water or on soil;
9. a determination of whether the spill will migrate off the ROW;
10. a determination of whether the spill is under control;

11. a statement verifying that clean-up has begun and a description of the methods being used to clean up the spill.

### 5.3 CLEAN UP EQUIPMENT

The Contractor will prepare a list of the type, quantity, and location of storage or containment and clean up equipment to be used on the construction site. The list will include the procedures and impact minimization measures to be used in response to a spill. The Contractor's choice of mitigation measures and equipment will be tailored to meet the characteristics of the affected terrain as well as the types and amounts of material that could potentially be spilled.

#### 5.3.1 TERRESTRIAL CONSTRUCTION

##### 5.3.1.1 General

General equipment for spill containment and cleanup on terrestrial areas includes:

1. Sorbents including pillows, socks, and wipe sheets for containment and pick up of spilled liquids;
2. Commercially available spill kits (or the functional equivalent thereof) that are self-contained and prepackaged with a large variety of sorbents for both small to large spills;
3. Structures such as gutters, culverts, and dikes for immediate spill containment, where available and appropriate;
4. Shovels, backhoes, etc, for excavating contaminated materials;
5. Sumps and collection systems; and
6. Drums, barrels, and temporary storage bags to clean up and transport contaminated materials.

### **5.3.1.2 Fuels and Lubricating Oil Storage**

The potential for large spills exists wherever fuels and hydraulic fluids are stored. The Contractor will take precautions in areas where trucks carrying fuel are loaded and areas where oil barrels are loaded, and will implement special measures to prevent spills in these areas. Containment equipment will be kept close to tanks and barrels to minimize spill response time, and will include absorbent pads or mats. The quantity and capabilities of the mats will be sufficient to capture the largest foreseeable spill, given ROW characteristics and crankcase and other fuel vessel capacities.

### **5.3.1.3 Routine Refueling and Maintenance**

Prevention is the preferred alternative for controlling common, small spills that often occur when crankcase oil is changed, hydraulic lines are repaired, and coolants are added to equipment. Absorbent pads and mats, will be placed on the ground beneath equipment before refueling and maintenance. Sorbent materials will be carried to each piece of equipment by maintenance personnel. Equipment that will be stored on site for routine refueling and maintenance includes small sorbent kits (or their functional equivalent).

### **5.3.1.4 Equipment Failure**

Spills can result from unforeseen events such as the rupturing of fuel tanks, radiators, and hydraulic lines. Kits with the capacity of absorbing up to 20 liters of liquid can fit beneath the operator's seat on construction equipment.

## **5.3.2 Waterbody and Wetland Crossings**

For each waterbody and wetland crossed, the equipment listed below will be available in addition to that needed for terrestrial construction. This equipment will be stored close to the water or wetland to minimize response time, and will include:

1. Oil containment booms and the related equipment needed for rapid deployment, and
2. Equipment to remove oils from water, such as oleophilic and hydrophobic absorbent booms and mats, and/or mechanical skimmers.

## **6.0 WASTE AND HAZARDOUS MATERIALS MANAGEMENT AND DISPOSAL**

### **6.1 SOLID WASTE**

Solid waste management will be implemented based on the following principles:

1. Minimize waste generation.
2. Maximize recycling and reusing.
3. Dispose waste appropriately.

Appropriate disposal facilities will be provided during the construction phase. Solid waste will be collected in clearly identified receptacles located at strategic points along the pipeline route and within work camps, staging areas, and other associated facilities. Plastics, metals, or any other non-biodegradable materials brought to the work site will be discarded into appropriate containers and/or containment facilities and/or disposed of at appropriate facilities, which may include sanitary landfills at workers camps. Recycling of materials will occur whenever possible. Paper, wood and other dry refuse may be burned in a pre-constructed pit. No plastics or synthetic polymer materials will be burned.

### **6.2 SANITARY WASTE**

Extended aeration package plants or conventional septic systems will be constructed for disposal of sanitary wastes in areas of high worker concentration such as work camps. Where possible, discharge of treated effluent will be to upland areas away from water bodies. If discharge is to receiving waters, the potential for assimilation of treated effluent will be considered in selecting receiving streams. Waste water from work camps may be disposed by land application in appropriate areas.

### **6.3 HAZARDOUS WASTE**

Hazardous waste generated during the construction of the pipeline will be collected, properly contained, and transported to temporary storage areas at work camps or at designated locations along the pipeline route. Temporary storage areas will be sited away from surface waters, wetlands, and agricultural areas. Such wastes will be transported to a central location for collection and disposal. One person (or one person at each collection/disposal facility) will be responsible

for collecting, inventorying, and disposing of hazardous waste. The management and disposal of hazardous waste will be conducted and documented in accordance with Bolivian regulations and/or sound environmental management practices.

## **7.0 AIR QUALITY PROTECTION AND NOISE CONTROL**

### **7.1 AIR QUALITY**

The following measures will be applied to prevent or minimize impacts to air quality.

1. All engines will be properly maintained to minimize emissions of contaminants.
2. A schedule for the operation of engines will be established to minimize, to the extent practicable, the time of operation of emission sources.
3. Detail design will consider modifications to stack height and other parameters related to the operation of the compressor stations to ensure compliance with applicable regulations.
4. If water is available, wetting will be used to minimize dust dispersion.

### **7.2 NOISE CONTROL**

Noise impacts are expected to be less than significant. Workers who are exposed to noise generators, such as compressors or heavy machinery, will be provided with hearing protection, appropriate for the noise level and time weighted exposure.

## **8.0 VEGETATION AND WILDLIFE PROTECTION**

### **8.1 GENERAL**

While some direct effects on vegetation and wildlife as a result of right-of-way clearing and construction activities are unavoidable, the objectives of these measures are to minimize those impacts and to prevent secondary impacts such as increased hunting pressure. Primary goals of the vegetation and wildlife protection plan include:

- Protection of rare, threatened, or endangered species.
- Minimization of disturbance during construction.
- Avoidance of hunting pressure on protected species or important indigenous species.
- Restoration of disturbed areas to extent possible to prevent long-term impacts.

## **8.2 SPECIES OF SPECIAL CONCERN**

While no specific regulations are in place to prevent harm to species of special concern, efforts will be made to minimize disturbance to flora and fauna encountered along the pipeline corridor and in the vicinity of work camps, storage yards, and other facilities associated with the project. Such efforts include:

1. Avoiding disturbance to areas outside approved construction zones.
2. Limiting access to construction areas or associated facilities/activities.
3. Informing workers of status and protection of wildlife and penalties for infractions.
4. Providing workers with materials depicting protected species which must not be harmed or harassed.
5. Instructing workers on appropriate protocols in the event of accidental injury or mortality to wildlife.

Clearing of vegetation outside construction areas will be strictly prohibited. The collection of plants or plant parts outside the construction area will be discouraged. Adherence to these rules will be emphasized during training and enforced during construction.

Indigenous wildlife may be abundant in some locations. Hunting or harassing of any wildlife will not be allowed or tolerated. Possession of weapons and hunting or killing of any wildlife by workers will be grounds for immediate dismissal. Access may be limited in certain areas to minimize further hunting pressure. Species of special concern likely to be encountered during construction activities include those listed in Table EMP-1.

If a species of special concern is encountered, injured, or killed during construction, the Environmental Inspector must be notified immediately. No attempt should be made to move or handle such animals until the Environmental Inspector approves it. If animals are in the way of construction, they should be allowed to leave the area on their own.

## **9.0 ACCIDENTAL DISCOVERY OF CULTURAL RESOURCES AND HUMAN REMAINS**

### **9.1 CULTURAL RESOURCES**

Cultural sites (archeological or historical) are occasionally encountered during construction. Project planning and a preliminary resource review will minimize discoveries, but it is possible that construction may have an effect on a site. This plan will be implemented during project construction in the unlikely event of such unanticipated discoveries.

#### **9.1.1 Identification**

If unidentified archeological or historical resources are discovered in spite of avoidance measures, the following steps will be undertaken:

1. The Environmental Inspector will halt activities in the immediate area of the discovery and make reasonable efforts to avoid or minimize damage to the cultural resource.
2. The Archaeological Department of the Bolivian Ministry of Education and Culture and local authorities will be contacted by the Chief Environmental Inspector and advised of the nature of the discovery.
3. As much information as possible concerning the cultural resource, such as resource type (archaeological or architectural), location, size as well as any information on its significance, will be provided.

If necessary, the Project Sponsors, in consultation with the Archaeological Department of the Ministry of Education and Culture, will order a technical reconnaissance to define the importance or merit of the discovery. The Chief Environmental Inspector will consult a qualified archaeologist and draw up a certificate that will record the discovery, and specifications and conditions of the objects encountered. Construction activities will not resume in the discovery area until approval is received from the Project Sponsors' Environmental Manager.



**9.1.2 Treatment**

If the site requires special treatment, a mitigation plan will be prepared by the Project Sponsors in concert with the Archaeological Department of the Ministry of Education and Culture for the cultural resource discovered.

Whenever feasible, preservation in place shall be preferred treatment. Historic properties may be avoided through:

1. Project design changes such as realignments and shifts in the pipeline right-of-way.
2. Shifts in the locations of the aboveground facilities.
3. Shifts in the location of construction staging areas, extra work spaces, access roads, disposal areas, or other support areas.
4. The use of temporary fencing or barricades to protect sites so that the sites will not be disturbed.

Special design changes include:

1. Directional drilling or boring beneath the property; or
2. Specialized mitigation measures or construction techniques, such as matting, with a plan for monitoring effects and/or a data recovery plan; or
3. Data recovery.

If data recovery is determined to be the most feasible and prudent treatment option, then the Project Sponsors will develop a data recovery plan in consultation with the Archaeological Department of the Ministry of Education and Culture. The Project Sponsors will make a reasonable effort to avoid any further impacts to the resource until a formal data recovery mitigation plan can be approved and implemented.

Any archaeological pieces encountered will be presented to the nearest authority within jurisdiction; the authority will then remit the pieces to the Archaeological National Institute.

## **9.2 HUMAN REMAINS**

The discovery and/or disturbance of human remains is a sensitive issue that must be addressed if the situation arises. It is possible that human remains could be encountered if an unmarked grave or a cemetery is impacted by construction. If human remains are discovered inadvertently or cannot be avoided, the following guidelines will be followed:

1. In the event human remains are discovered during line survey or prior to construction, the Project Sponsors will consult with local authorities or appropriate interested parties to determine which groups and/or representatives should be notified of the discovery. The Chief Environmental Inspector will notify those groups and or representatives of the nature and location of the discovery.
2. If unexpected human remains are encountered during construction, the work in that locale will be stopped immediately, and the Environmental Inspector will take steps to avoid damage to those remains, as well as to protect them, pending consultation with the local authorities and the Archaeological Department of the Ministry of Education and Culture.
3. The Chief Environmental Inspector will notify local authorities and the Archaeological Department of the Ministry of Education and Culture as soon as practical after learning about the presence of human remains.
4. If the remains are of archaeological importance, local authorities and the Archaeological Department of Ministry of Education and Culture will be asked to provide technical advice and guidance in preparing a plan for the avoidance of any further impact on the discovered human remains and/or mitigative excavation, re-interment, or a combination of these treatments, as appropriate. The Project Sponsors will implement such plan at its expense.
5. If warranted, the Project Sponsors will provide a qualified professional archaeologist to investigate the reported discovery. If necessary, alternative work areas that will avoid any further effect on the burial site will be evaluated.
6. The Project Sponsors or its agent will treat all discovered human remains with dignity and respect until they are re-interred. Any costs that accrue as a result of consultation, treatment, re-interment, etc., will be the responsibility of the Project Sponsors.

## **10.0 ABANDONMENT**

The pipeline is being constructed as part of a contract between the countries of Bolivia and Brazil for the supplies of additional natural gas to Brazil over the next twenty years. No plans for abandonment have been developed at this time.

Should abandonment become necessary, standard industry accepted procedures will be followed. Such procedures typically include removal of sections of pipe where necessary due to exposure or potential conflicts with future use, and capping and abandoning in place sections of pipe where removal is not necessary. Both ends of the pipeline will be disconnected and all openings will be closed and sealed. Where the pipeline is subject to pressures or external forces such as those caused by geologic fault sites or landslides, the pipe will be filled with an inert material from the local area (if possible) and sealed. Abandonment in place is preferred as a means of limiting environmental impacts.

All equipment from compressor stations will be dismantled and removed from the area. If appropriate, building structures will be assigned to alternate uses compatible with the station environment. Otherwise, such structures will be demolished and their foundations will be removed to allow site restoration to preconstruction conditions to the extent possible.

## **11.0 COMPENSATORY MITIGATION PROGRAM**

In addition to the mitigating measures which will be implemented during construction and operation of the pipeline to minimize environmental impacts, a compensatory mitigation program will be provided to offset potential impacts in the vicinity of the Gran Chaco National Park. The pipeline will mark the northern boundary of the Gran Chaco National Park, and will be within the boundary of the Integrated Management Area. Secondary impacts of the pipeline may include the risk of colonization of areas in and around the park due to the establishment and maintenance of the right-of-way; however this potential is deemed low. These impacts may affect the physical environment, biological, and human environment.

The Project Sponsors will make a contribution to the endowment fund for the park as an offset mitigation for direct and potential indirect impacts of the project. Revenues from the contribution will be earmarked for management of the parks in the Department of Santa Cruz funded through this program. Administration of the funds will be managed by the National Secretary of Natural Resources and the Environment.

The project will require the establishment of water wells and generators at different locations. During detail design, provisions will be incorporated to the extent possible to ensure that these

## *ENVIRONMENTAL MANAGEMENT PLAN*

facilities are left for the continuing benefit of the neighboring communities. The additional water and energy sources will help the communities satisfy their growing needs for water and energy.

Provisions will be made to compensate land owners for damages resulting from the project. During final design, a complete assessment of land ownership and agricultural areas will be made in order to carry out any necessary negotiations to compensate anticipated impacts.

### **12.0 COST OF THE EMP**

A budget will be established by the project sponsors to fund the implementation of the Environmental Management Plan. The Turnkey Contractor will be responsible for implementation and QA/QC for the EMP. Costs are included in the lump sum Turnkey Contract. All activities and costs represented in Table EMP-2 are the responsibility of the Turnkey Contractor and are included in the Turnkey price. In addition, the project sponsors will have an owners' technical staff that will include an Environmental Manager and Environmental Inspectors to audit the Contractor to ensure that QA/QC is being properly managed.

- o o o -

**TABLE EMP-1**  
**LIST OF ENDEMIC, ENDANGERED, AND ECONOMICALLY IMPORTANT PLANT AND ANIMAL SPECIES IN THE STUDY AREA**

PLANTS							
COMMON NAME	SCIENTIFIC NAME	FAMILY	GROWTH FORM	USES	HABITAT	STATUS	SOURCE
Cuchi, Urundel	<i>Astronium urundeuva</i>	ANACARDIACEAE	Tree to 20 m	Timber, medicinal	Forests of the Cerrado, subhumid-humedo Chaco	Threatened, excessive cutting	Bibliography
Guayacan	<i>Bulnesia sarmientoi</i>	ZIGOPHYLLACEAE	Tree to 20 m	Timber, essential oils	Forests of the Chaco	Threatened	CITES, Bibliography
Alcornoque	<i>Tabebuia aurea</i>	BIGNONIACEAE	Tree to 6 m	Forestry, medicinal	Wooded savannahs of the Cerrado	Very frequent	Bibliography
Ajo ajo	<i>Gallesia integrifolia</i>	PHYTOLACACEAE	Tree to 20 m	Forestry, medicinal	Forests of the Cerrado, gallery forests	Very frequent	Bibliography
Chaáco	<i>Curatela americana</i>	DILLENACEAE	Tree to 5 m	Medicinal	Wooded savannahs	Very frequent	Bibliography
Cupesí	<i>Prosopis chilensis</i>	FABACEAE	Tree to 12 m	Forestry, medicinal	Alluvial plains in forests of the Chaco	Very frequent	Bibliography
Curupaú	<i>Anadenanthera colubrina</i>	FABACEAE	Tree to 15 m	Forestry, medicinal	Tall forest of the Cerrado	Very frequent	Bibliography
Cusi	<i>Attalea phaleratta</i>	ARECACEAE	Palm to 15 m	Forestry, oil extraction, medicinal	Forests of the Cerrado	Very frequent	Bibliography

Table 4.2 continuation...

PLANTS							
COMMON NAME	SCIENTIFIC NAME	FAMILY	GROWTH FORM	USES	HABITAT	STATUS	SOURCE
Carandai	<i>Copernicia alba</i>	ARECACEAE	Palm to 15 m	Leaves used for hats, trunk for posts, ornamental	Marsh areas, Bañados, Pantanal	Very frequent	Bibliography
Caparosa	<i>Victoria amazonica</i>	NYMPHACEAE	Aquatic plant, floating leaves	Medicinal, ornamental	Ponds, Pantanal	Very frequent	Bibliography
Coco	<i>Guazuma ulmifolia</i>	STERCULIACEAE	Tree to 12 m	Forestry, medicinal	Gallery forests	Frequent	Bibliography
Guayacán	<i>Caesalpinia paraguariensis</i>	FABACEAE	Tree to 12 m	Forestry	Gallery forests	Frequent, need to protect	Bibliography
Motacuchi	<i>Allagoptera leucocalyx</i>	ARECACEAE	Stemless palm	Medicinal, essential oils extracted from seeds	Wooded savannahs	Very frequent	Bibliography
Paraparau	<i>Jacaranda cuspidifolia</i>	BIGNONIACEAE	Tree to 12 m	Forestry, medicinal	Wooded savannahs, forests of the Cerrado	Very frequent	Bibliography
Penoco	<i>Samanea saman</i>	FABACEAE	Tree to 8 m	Medicinal	Wooded savannahs	Very frequent	Bibliography
Paquió	<i>Hymenaea courbaril</i>	FABACEAE	Tree to 7 m	Forestry, used for making tools	Forests of the Cerrado, Subhumid Chaco	Frequent	Bibliography
Soto	<i>Schinopsis brasiliensis</i>	ANACARDIACEAE	Tree to 15 m	Forestry, used for making tools	Forests of the Cerrado, Subhumid Chaco	Frequent	Bibliography

Table 4.2 continuation...

PLANTS							
COMMON NAME	SCIENTIFIC NAME	FAMILY	GROWTH FORM	USES	HABITAT	STATUS	SOURCE
Roble	<i>Amburana cearensis</i>	FABACEAE	Tree to 12 m	Forestry, used for making musical instruments	Forests of the Cerrado	Ocassional	Bibliography
Cacha	<i>Aspidosperma quebracho-blanco</i>	APOCYNACEAE	Tree to 20 m	Forestry, used for tracks, posts, constructions	Forests of the Chaco	Frequent	Bibliography
	<i>Cleitocactus chacoanus</i>	CACTACEAE	Columnar to 1 m		Forests of the Chaco	Endemic, dry Chaco	Bibliography
	<i>Echinopsis klingeriana</i>	CACTACEAE	Globular		Forests of the Chaco	Endemic, dry Chaco	Bibliography
	<i>Gymnocalycium damsii var torulosum</i>	CACTACEAE	Globular		Forests of the Chaco	Endemic Chaco	Bibliography
	<i>Gymnocalycium damsii var tucavocense</i>	CACTACEAE	Globular		Forests of the Chaco	Endemic Chaco	Bibliography
	<i>Gymnocalycium griseo-pallidum</i>	CACTACEAE	Globular		Forests of the Chaco	Endemic Chaco	Bibliography
	<i>Gymnocalycium pflanzii var izozogsii</i>	CACTACEAE	Globular		Forests of the Chaco	Endemic Chaco	Bibliography
	<i>Monvillea chacoana</i>	CACTACEAE	Columnar		Forests of the Chaco	Endemic Chaco	Bibliography

Table 4.2 continuation...

PLANTS							
COMMON NAME	SCIENTIFIC NAME	FAMILY	GROWTH FORM	USES	HABITAT	STATUS	SOURCE
Cacha	<i>Monvillea ebenacantha</i>	CACTACEAE	Columnnar		Forests of the Chaco	Endemic Chaco	Bibliography
	<i>Monvillea parapetiensis</i>	CACTACEAE	Columnnar		Forests of the Chaco	Endemic Chaco	Bibliography

ANIMALS					
MAMMALS:					
COMMON NAME	SCIENTIFIC NAME	CATEGORY	CAUSES	HABITAT	SOURCE
Anta	<i>Tapirus terrestris</i>	CITES II	Uncontrolled hunting, habitat destruction, meat consumption	Subhumid forests, wetlands of the Chaco and the Cerrado	Bibliography, CITES
Pecarí	<i>Tayassu tajacu</i>	CITES II	Uncontrolled hunting, meat consumption	Subhumid forests, wetlands of the Chaco and the Cerrado	Bibliography, CITES
Tropero	<i>Tayassu albirostris</i>	CITES II	Hunting, meat consumption	Subhumid forests, wetlands of the Chaco and the Cerrado	Bibliography, CITES
Choco	<i>Catagonus wagneri</i>	CITES I, endemic	Hunting, meat consumption	Subhumid forests, wetlands of the Chaco	Bibliography
Urina	<i>Mazama americana</i>	Threatened	Hunting, meat consumption	Forests of the Cerrado and the Chaco	Bibliography



Table 4.2 continuation...

MAMMALS:					
COMMON NAME	SCIENTIFIC NAME	CATEGORY	CAUSES	HABITAT	SOURCE
Pejichi, Tatú carreta	<i>Priodontes maximus</i>	Threatened	Habitat destruction	Forests of the Cerrado and the Chaco	Bibliography
Jaguar, Tigre	<i>Panthera onca</i>	Threatened	Habitat destruction, uncontrolled hunting, fur trade	Forests of the Cerrado and the Chaco	Bibliography
León, Puma	<i>Felis concolor</i>	Threatened	Habitat destruction, uncontrolled hunting	Forests of the Cerrado and the Chaco	Bibliography
Ciervo de los pantanos	<i>Blastocerus dichotomus</i>	CITES I	Uncontrolled hunting, meat consumption	Bañados and Pantanal areas	Bibliography, CITES
Venado	<i>Ozotocerus bezoarticus</i>	Threatened	Hunting, meat consumption	Forests of the Chaco and the Cerrado	Bibliography
Capibara, Carpincho	<i>Hydrochaeris hydrochaeris</i>	Threatened	Hunting, meat consumption, fur trade	Ponds of the Pantanal and Bañados	Bibliography
Londra	<i>Pteronura brasiliensis</i>	CITES II, endangered	Hunting, fur trade	Ponds of the Pantanal, Bañados, and rivers	Bibliography, CITES
Lobito de río	<i>Lutra longicaudis</i>	CITES II, endangered	Hunting, fur trade	Ponds of the Pantanal, Bañados, and rivers	Bibliography, CITES
Borocho	<i>Chrysocyon brachiurus</i>	CITES	Habitat destruction	Hills and forests of the Cerrado and the Chaco	Bibliography, CITES
Mono araña	<i>Alouatta caraya</i>	CITES II	Habitat destruction	Subhumid-humid forests of the Cerrado and the Chaco	Bibliography, CITES

Table 4.2 continuation...

BIRDS:					
COMMON NAME	SCIENTIFIC NAME	CATEGORY	CAUSES	HABITAT	SOURCE
Paraba jacinta	<i>Anodorhynchus hyacinthinus</i>	CITES I, endemic	Trading, habitat destruction	Mountainous areas of the Mutún	Bibliography, CITES
Paraba roja	<i>Ara chloroptera</i>	CITES II, need to protect	Trading	Forests of the Cerrado and the Chaco	Bibliography, CITES
Tuyuyú, Bato	<i>Jabiru mycteria</i>	Need to protect	Habitat destruction	Area of the Pantanal, Bañados	Bibliography
Bato cabeza seca	<i>Mycteria americana</i>	Need to protect	Habitat destruction	Area of the Pantanal, Bañados	Bibliography
Cigüeña	<i>Ciconia maguari</i>	Need to protect	Habitat destruction	Area of the Pantanal, Bañados	Bibliography
Pato negro	<i>Cairina moschata</i>	Need to protect	Hunting, meat consumption	Ponds, Pantanal, and Bañados	Bibliography
Pava pintada	<i>Penelope jacquacu</i>	Endangered	Hunting, meat consumption	Forests of the Cerrado and the Chaco	Bibliography
Loro hablador	<i>Amazona aestiva</i>	CITES II, to protect	Commercialization	Forests of the Cerrado and the Chaco	Bibliography
Piyu, Ñandu	<i>Rhea americana</i>	Need to protect	Habitat destruction	Wood savannahs of the Cerrado	Bibliography
Cardenal	<i>Paroaria coronata</i>	CITES II, need to protect	Commercialization	Forests of the Cerrado and the Chaco	Bibliography, CITES
Tucán	<i>Ramphastos toco</i>	Threatened	Commercialization	Forests of the Cerrado and the Chaco	Bibliography

Table 4.2 continuation...

REPTILES:					
COMMON NAME	SCIENTIFIC NAME	CATEGORY	CAUSES	HABITAT	SOURCE
Peta	<i>Geochelone carbonaria</i>	CITES II, threatened	Hunting	Forests of the Cerrado and the Chaco	Bibliography
Lagarto	<i>Caiman yacare</i>	CITES II, endangered	Hunting, meat consumption, skin trading	Area of the Pantanal and Bañados	Bibliography, CITES
Iguana colorada, peni	<i>Tupinambis rufescens</i>	Threatened	Hunting, meat consumption	Region of the Cerrado and the Chaco	Bibliography
Peni	<i>Tupinambis teguixin</i>	CITES II, threatened	Hunting, meat consumption	Region of the Cerrado and the Chaco	Bibliography, CITES
Sicurí	<i>Eunectes notaeus</i>	Threatened	Hunting, skin trading	Region of the Pantanal and Bañados	Bibliography
Boyé	<i>Boa constrictor</i>	Threatened	Hunting, skin trading	Region of the Cerrado and the Chaco	Bibliography

FISHES:					
COMMON NAME	SCIENTIFIC NAME	CATEGORY	CAUSES	HABITAT	SOURCE
Surubí	<i>Pseudoplatistoma fasciatum</i>	Threatened, require management plan	Uncontrolled fishing, meat consumption	Area of the Pantanal	Bibliography
Pacú	<i>Colossoma macropomum</i>	Require management plan	Uncontrolled fishing, meat consumption	Area of the Pantanal	Bibliography
Dorado	<i>Salminus maxillosus</i>	Require management plan	Uncontrolled fishing, meat consumption	Area of the Pantanal	Bibliography

TABLE EMP-2 SUMMARY OF ESTIMATED COSTS ASSOCIATED WITH THE IMPLEMENTATION OF THE ENVIRONMENTAL MANAGEMENT PROGRAM					
EMP COMPONENT (CHAPTER SECTION)	MEASURE	UNIT	UNIT COST	NUMBER OF UNITS	TOTAL COST
Erosion Control, Revegetation	Revegetation of aeolic plains at Río San Miguel	Plants	Install plants; one-year survival guarantee included	12 ha (120,000 m <sup>2</sup> )	<b>Total \$180,000</b>
Environmental Inspection	Inspection Plan	Environmental Manager <sup>(1)</sup>	\$13,000/mo.	1 Manager (15 mos)	\$195,000
		Chief Inspector <sup>(1)</sup>	\$9,000/mo.	2 Chief Inspectors (10 mos)	\$180,000
		Inspectors <sup>(1)</sup>	\$7,000/mo.	4 Inspectors (9 mos)	\$252,000
		Trucks	\$3,200/mo.	1 Truck (15 mos) 2 Trucks (10 mos) 4 Trucks (9 mos)	\$227,200
		Fuel & Maintenance	\$750/mo.	1 Truck (15 mos) 2 Trucks (10 mos) 4 Trucks (9 mos)	\$53,250
					<b>Total \$907,450</b>
Compensatory Mitigation	National Park Management	Rangers, facilities, operations, and maintenance	Annual interest contributed toward operational cost	Donation to National Endowment Fund, estimated at 10% yearly return to cover investment and operating expenses	<b>Total \$1,000,000</b>

TABLE EMP-2					
SUMMARY OF ESTIMATED COSTS ASSOCIATED WITH THE IMPLEMENTATION OF THE ENVIRONMENTAL MANAGEMENT PROGRAM					
EMP COMPONENT (CHAPTER SECTION)	MEASURE	UNIT	UNIT COST	NUMBER OF UNITS	TOTAL COST
Protection of Wildlife and the Right-of-Way	Signage and Barricade Program	Signs & ROW	\$200/sign	560	\$112,000
		Barriers & Gates	\$1,400/gate	82	\$115,000
		<b>Total \$227,000</b>			
Community Relations	Water and Generator donation to the community	Well	\$80,000	4 - San José, Roboré, El Carmen, CABI	\$320,000
		Pumps and Other	\$25,000	4	\$100,000
		<b>Total \$420,000</b>			
		Generator (3)	\$76,000	1 - San José	\$76,000
			\$93,000	2 - El Carmen	\$186,000
<b>Total \$262,000</b>					
	Building	\$30,000	1 - Pailón	<b>Total \$30,000</b>	

TABLE EMP-2					
SUMMARY OF ESTIMATED COSTS ASSOCIATED WITH THE IMPLEMENTATION OF THE ENVIRONMENTAL MANAGEMENT PROGRAM					
EMP COMPONENT (CHAPTER SECTION)	MEASURE	UNIT	UNIT COST	NUMBER OF UNITS	TOTAL COST
Community Relations	Public Education Program	Professionals	Public Education Manager at \$40/hr	520 hr	\$20,800
			Public Education Trainers at \$20/hr	Two for 520 hr each	\$20,800
		Materials	Miscellaneous supplies and brochure materials	Enough to cover 3,000 people (panphlets)	\$20,000
				<b>Total</b>	<b>\$61,600</b>
	Public Communications Program	Public Communications Officer	One at \$2000/mo	For 2 years	<b>Total \$48,000</b>
<b>Total Cost of Mitigation Measures:</b>					<b>\$3,136,050</b>

<sup>(1)</sup> Salary plus living expenses.

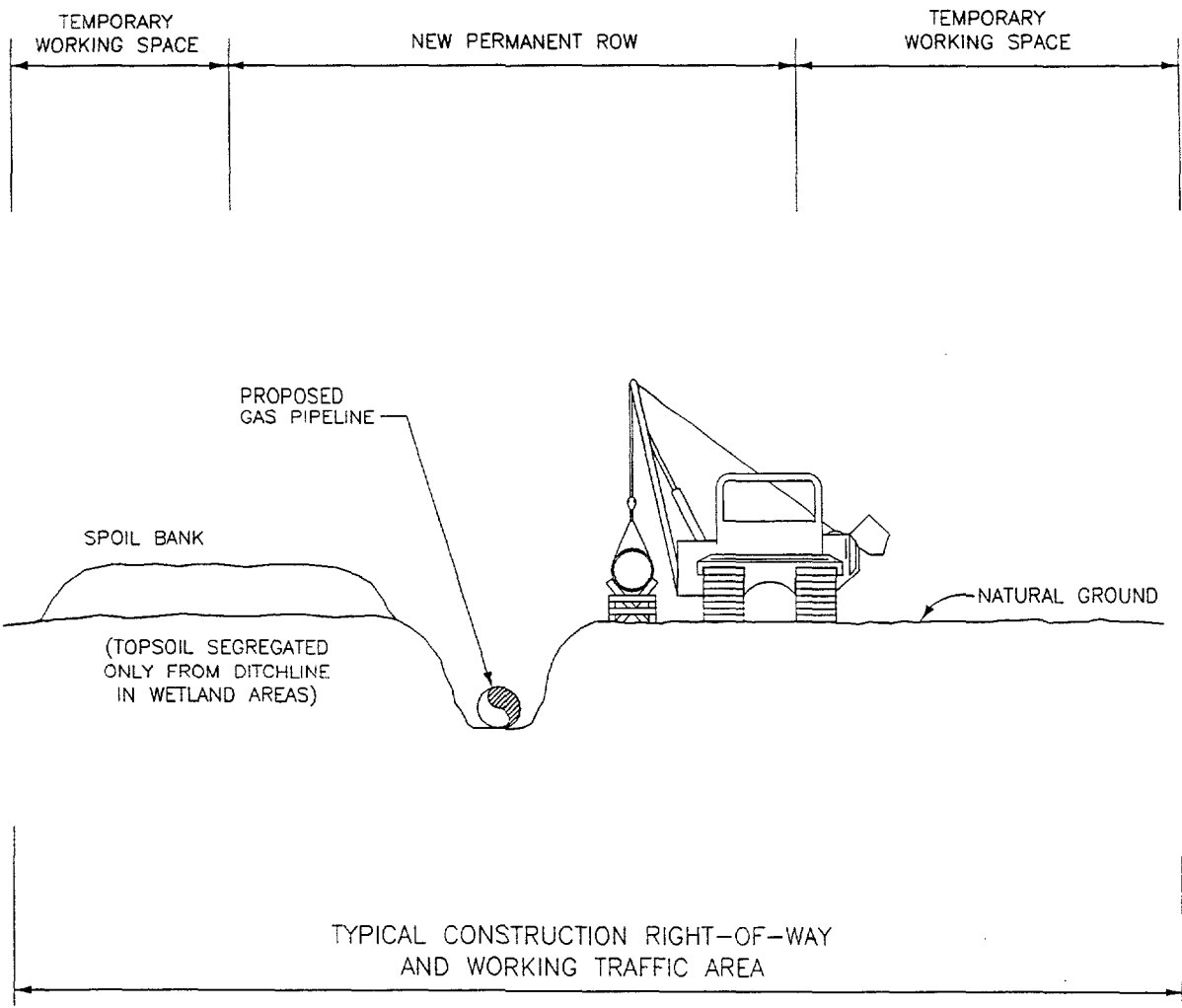

BOLIVIA TO BRAZIL GAS PIPELINE (BOLIVIAN PORTION)

TYPICAL CONSTRUCTION RIGHT-OF-WAY

 **Dames & Moore**

FIGURE 1

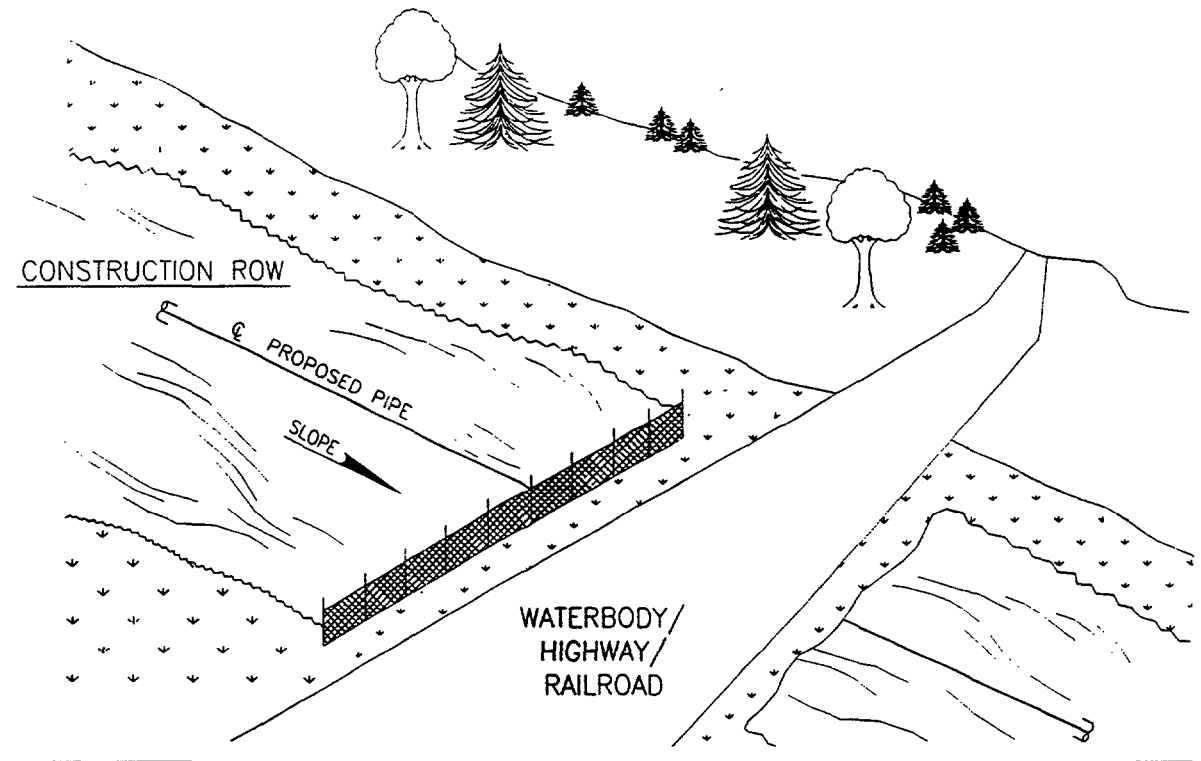

FRONT VIEW

1 Meter MIN. FENCE POSTS, DRIVEN  
MIN. 40cm INTO GROUND AS SITE  
CONDITIONS ALLOW

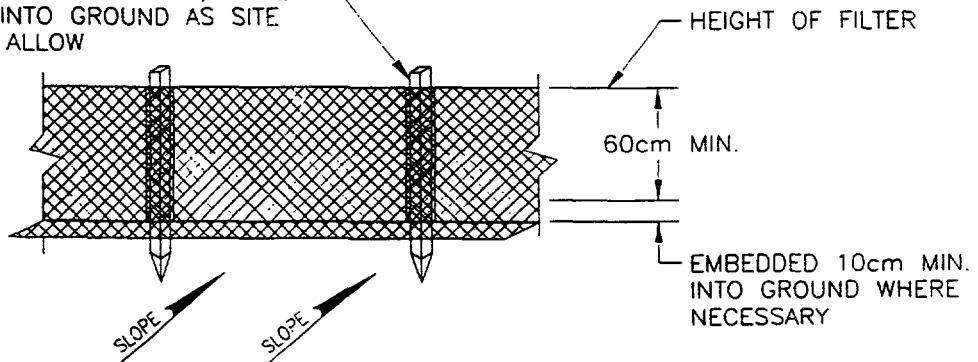

NOTE:

FENCE SHOULD BE INSTALLED SO POSTS  
ARE ON THE DOWNSLOPE SIDE OF THE FABRIC.

BOLIVIA TO BRAZIL GAS PIPELINE (BOLIVIAN PORTION)

FILTER FENCE CONSTRUCTION

 **Dames & Moore**

FIGURE 2



SIDE VIEW CROSS SECTION

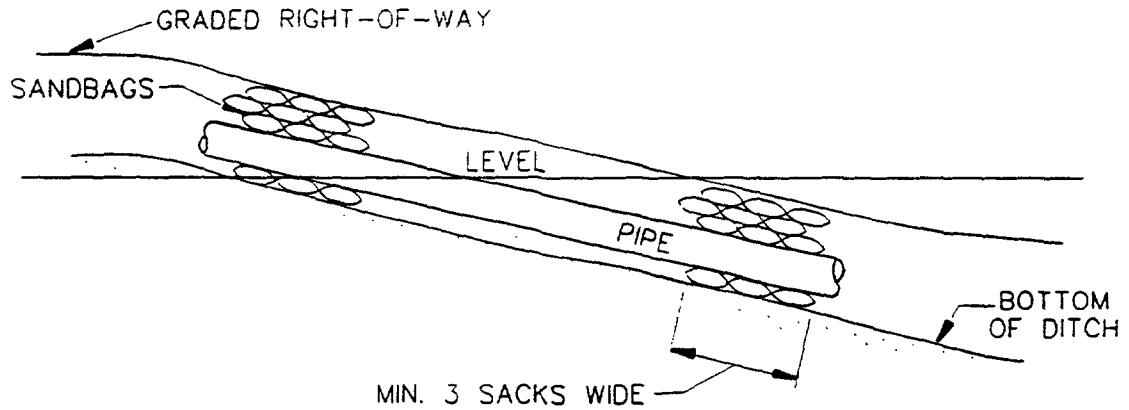

END VIEW CROSS SECTION

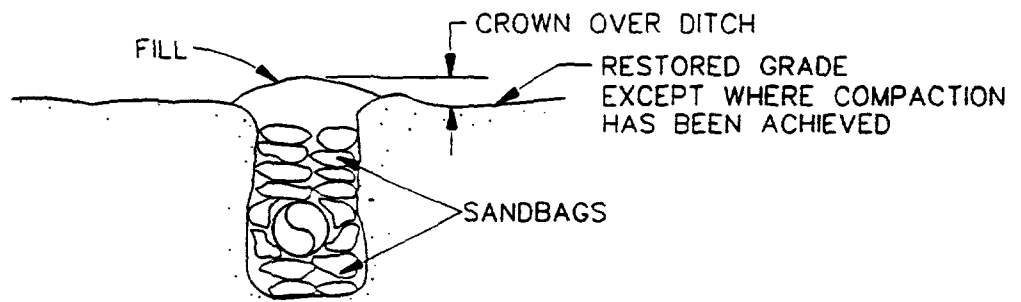

NOTE:

1. CONSTRUCT ON SLOPING TERRAIN.
2. PRIOR TO LOWERING IN PIPE REMOVE ALL DECOMPOSABLE MATERIAL AND LARGE ROCKS.
3. BREAKERS MAY BE COMPOSED OF SANDBAGS OR OTHER APPROVED MATERIAL.

BOLIVIA TO BRAZIL GAS PIPELINE (BOLIVIAN PORTION)

TYPICAL TRENCH BREAKERS

 **Dames & Moore**

FIGURE 3

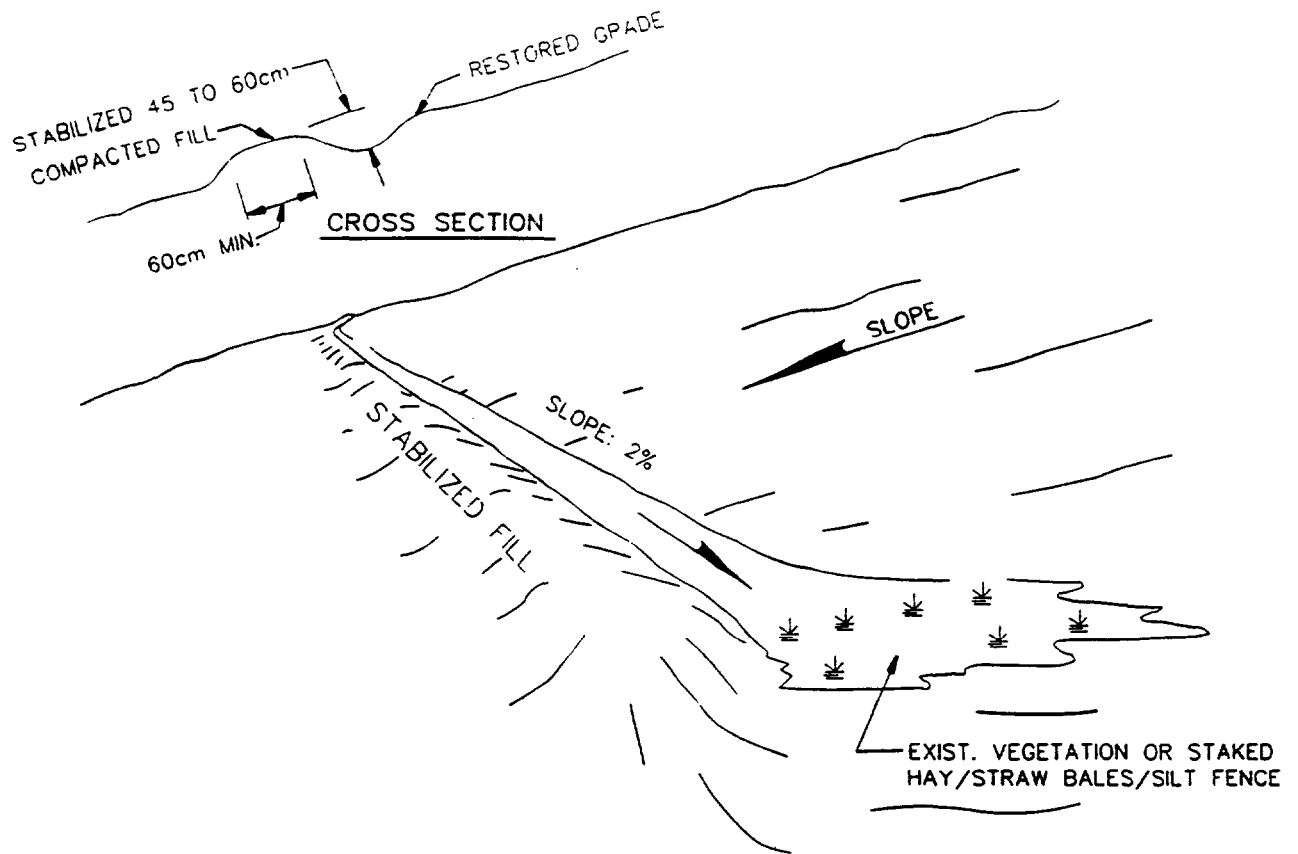

NOTES:

1. INSTALL ON SLOPING TERRAIN. AS REQUIRED
2. MAINTAIN THROUGHOUT CONSTRUCTION AND REPAIR AT THE END OF EACH DAY.
3. OUTLET INTO AREAS STABILIZED BY EXISTING VEGETATION OR INSTALL STAKED HAY/STRAW BALES/SILT FENCE.
4. CONTOUR TO ALLOW PASSAGE OF CONSTRUCTION EQUIPMENT.
5. MINIMUM 2% LATERAL SLOPE.
6. TERRACES SHOULD BE LOCATED AT INTERVALS NOT TO EXCEED 4.5m IN VERTICAL ELEVATION.

BOLIVIA TO BRAZIL GAS PIPELINE (BOLIVIAN PORTION)

PERMANENT WATER BARS OR TERRACES

 **Dames & Moore**

FIGURE 4

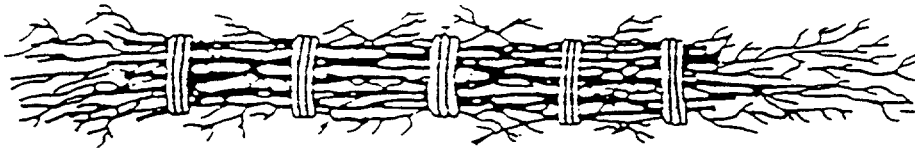

Prepare Wattling: Cigar-shaped bundles of live brush with butts alternating, 20-25cm dia, tied 30-40cm o.c. Species which root are preferred.

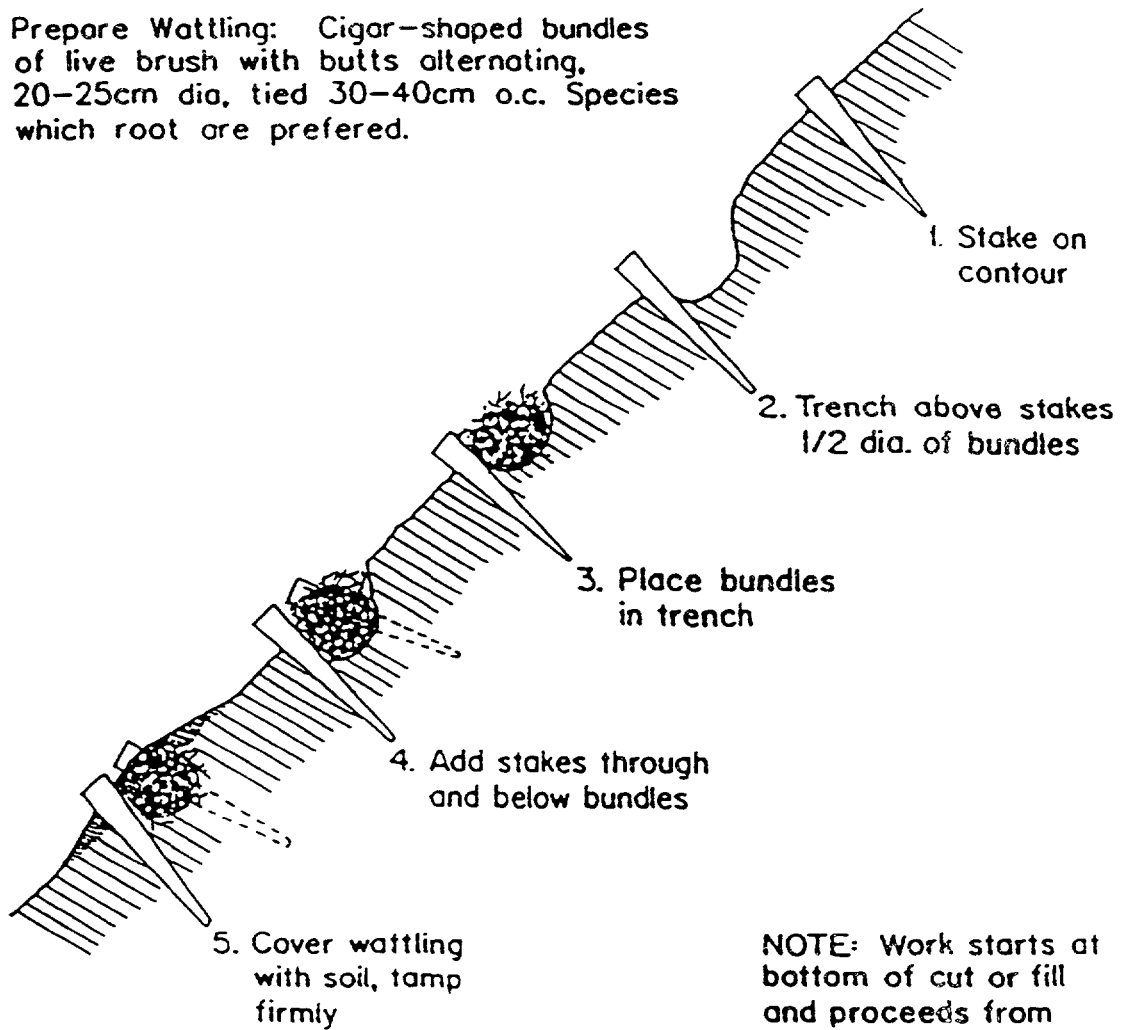

NOTE: Work starts at bottom of cut or fill and proceeds from Step 1 through Step 5

STAKE TO THE SLOPE WITH WOOD PEGS OR STAPLE PER MANUFACTURERS SPECIFICATION

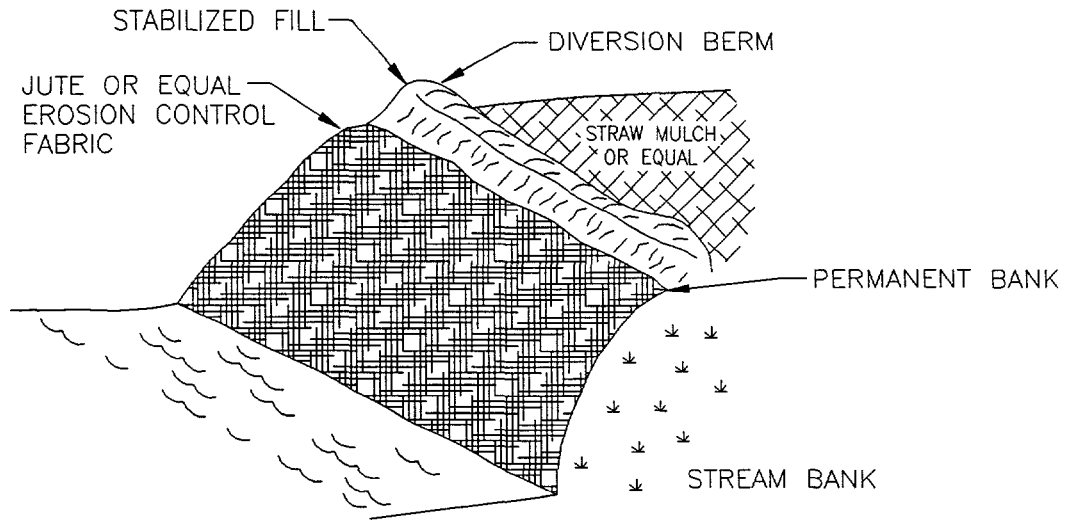

STRAW MULCH OR EQUAL OVER SEED & FERTILIZER

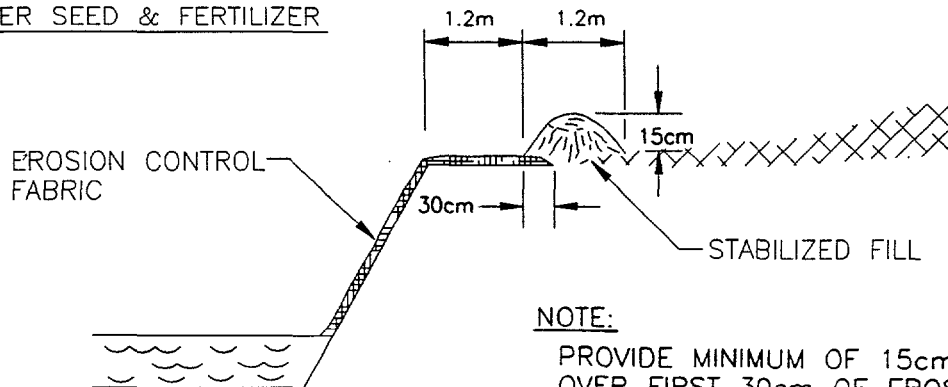

NOTE:

PROVIDE MINIMUM OF 15cm OF SOIL COVER OVER FIRST 30cm OF EROSION CONTROL FABRIC AS SHOWN.

SLOPE SECTION

BOLIVIA TO BRAZIL GAS PIPELINE (BOLIVIAN PORTION)

TYPICAL EROSION CONTROL FABRIC

 **Dames & Moore**

FIGURE 6

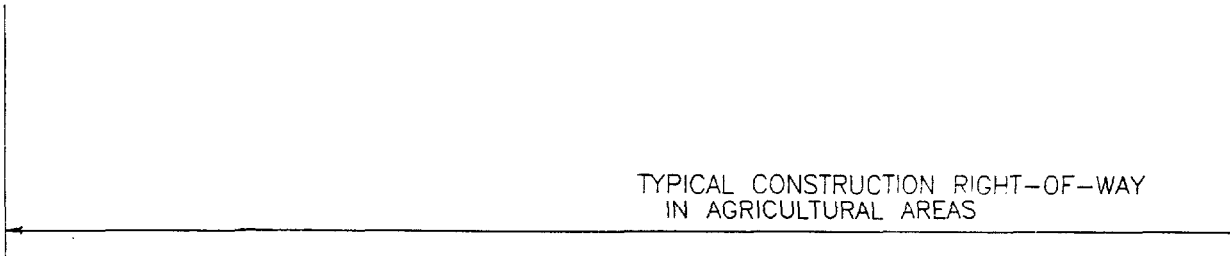
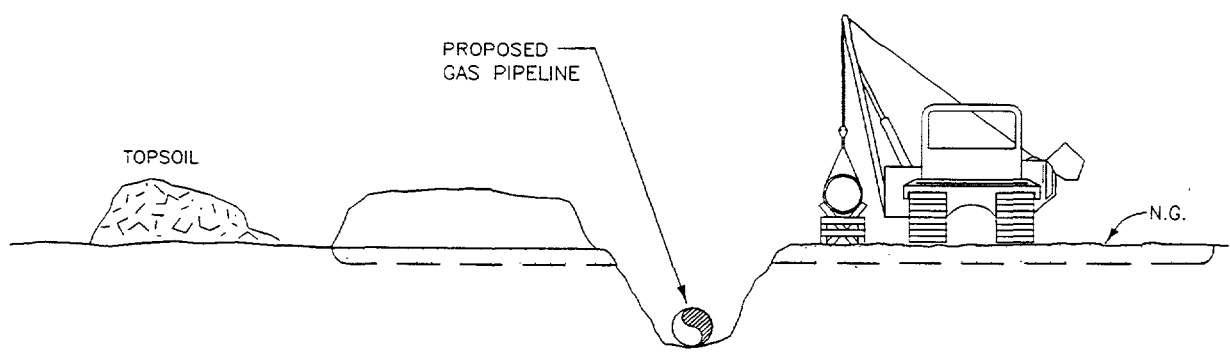
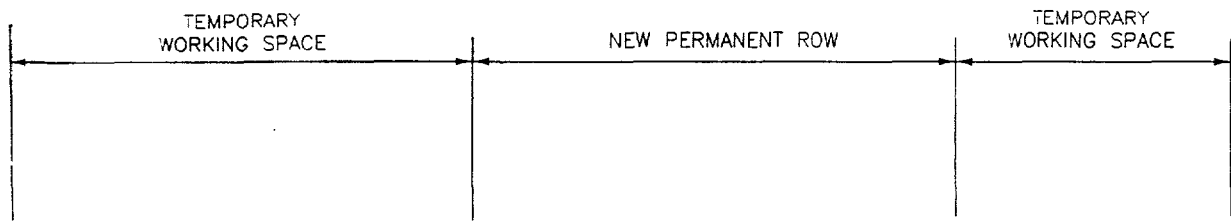

TYPICAL CONSTRUCTION RIGHT-OF-WAY  
IN AGRICULTURAL AREAS

BOLIVIA TO BRAZIL GAS PIPELINE (BOLIVIAN PORTION)  
TYPICAL ROW IN AGRICULTURAL  
AREAS



FIGURE 7

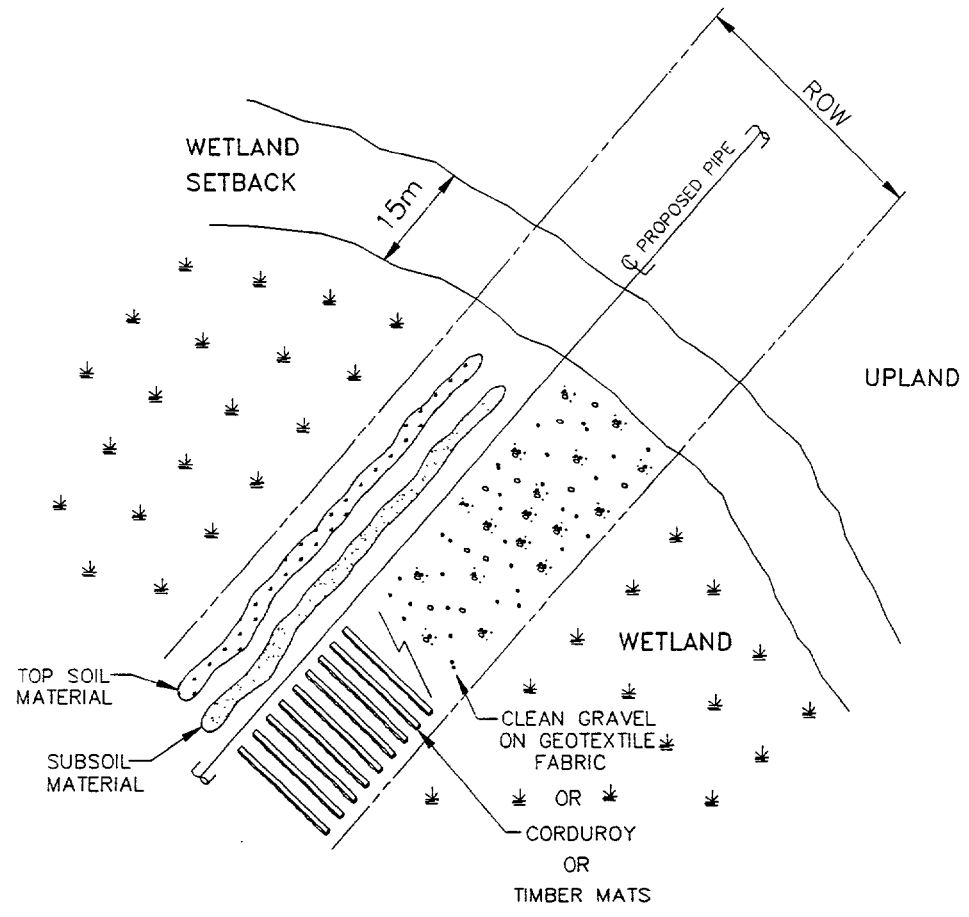
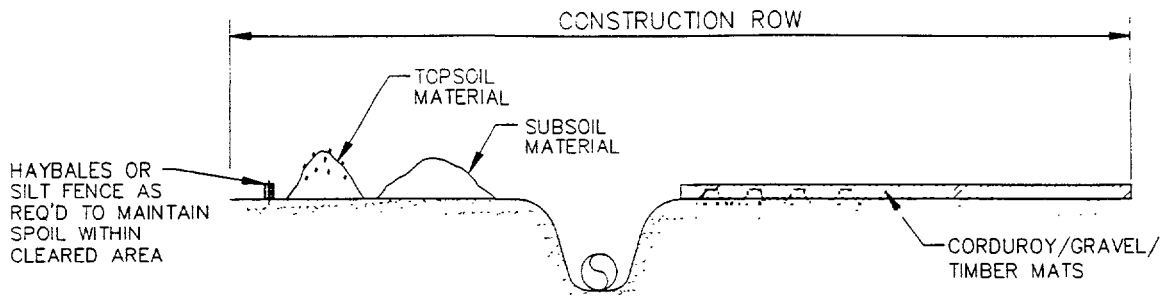

BOLIVIA TO BRAZIL GAS PIPELINE (BOLIVIAN PORTION)

CONVENTIONAL WETLAND CONSTRUCTION  
(METHOD II)



FIGURE 8

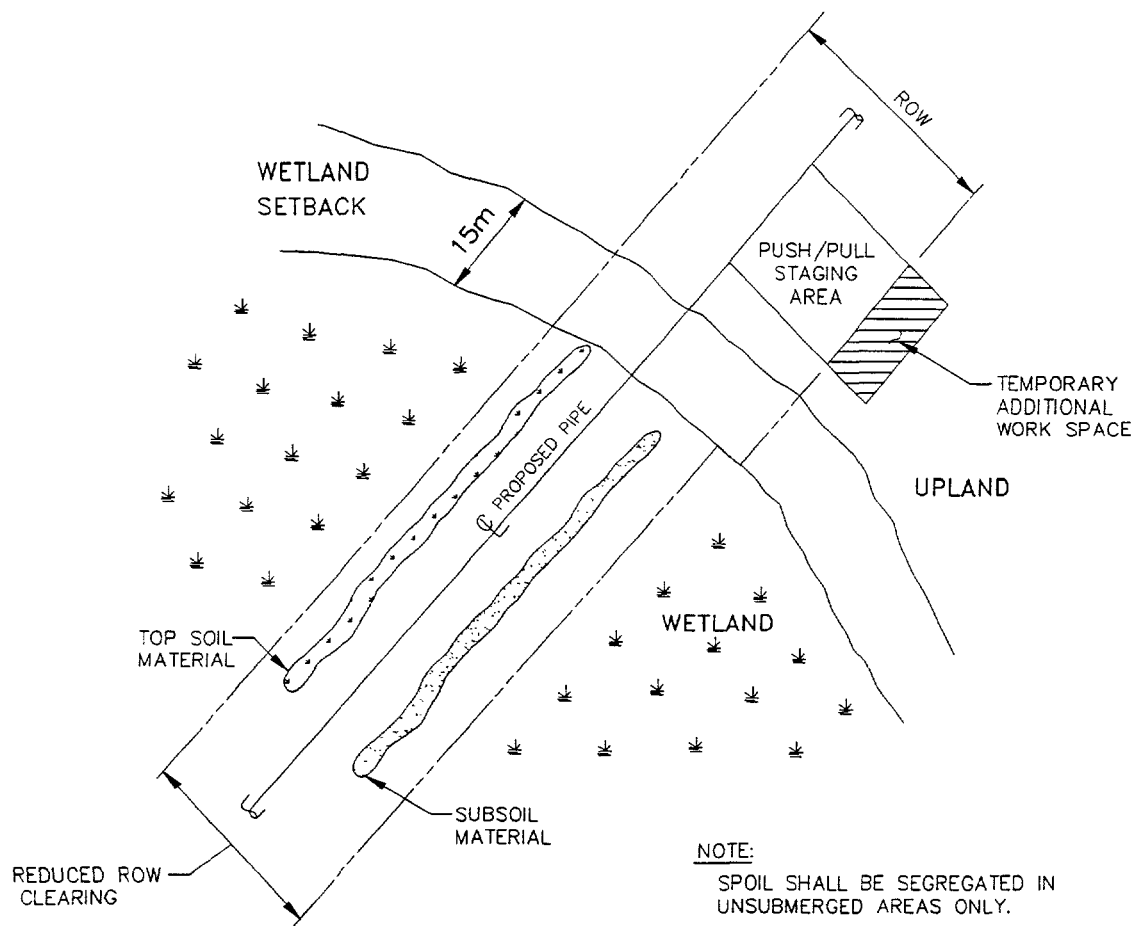
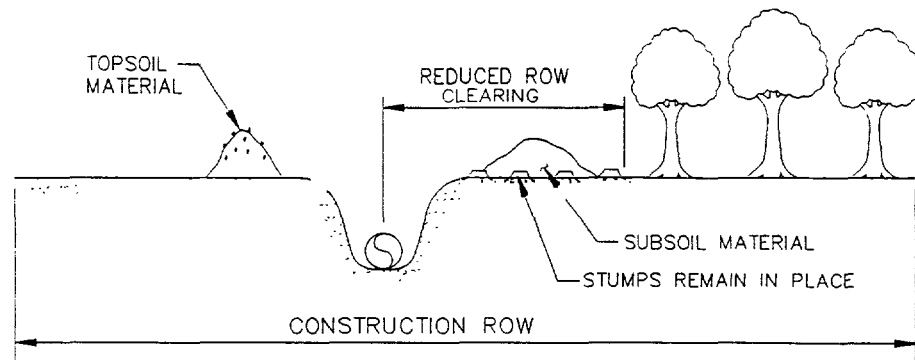

NOTE:  
SPOIL SHALL BE SEGREGATED IN UNSUBMERGED AREAS ONLY.

BOLIVIA TO BRAZIL GAS PIPELINE (BOLIVIAN PORTION)  
PUSH/PULL WETLAND CONSTRUCTION  
(METHOD III)

 **Dames & Moore**

FIGURE 9

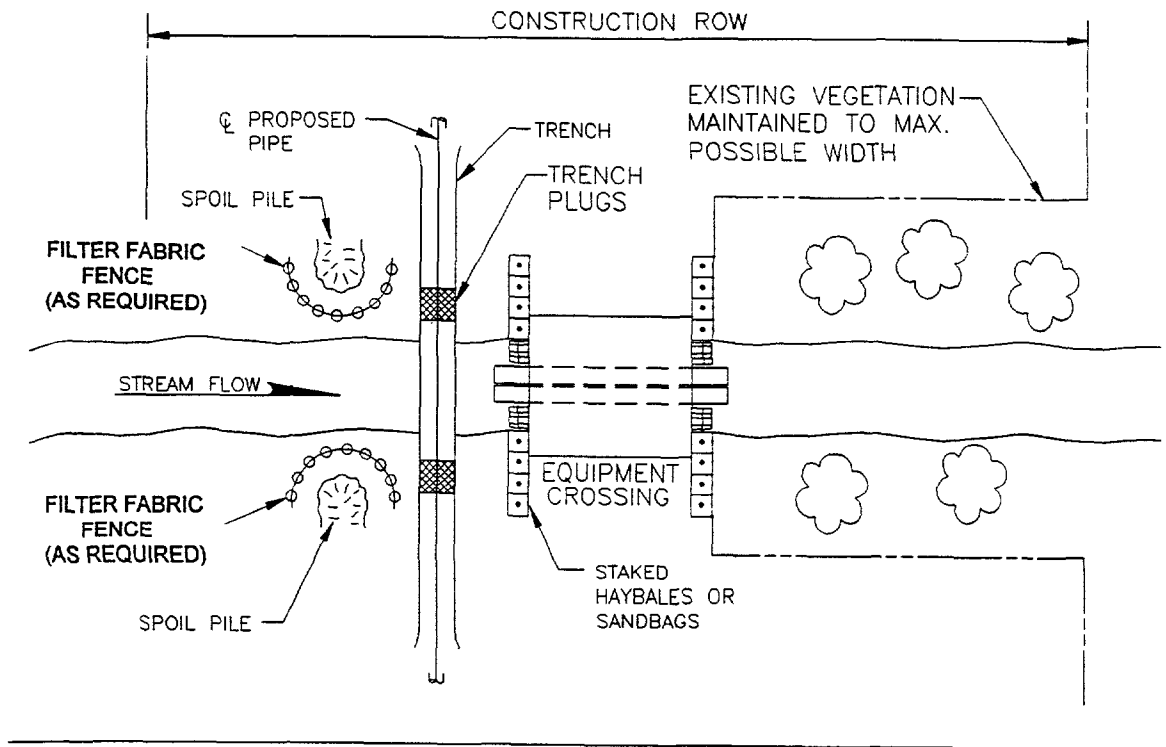

CROSS SECTION FOR EQUIPMENT CROSSING

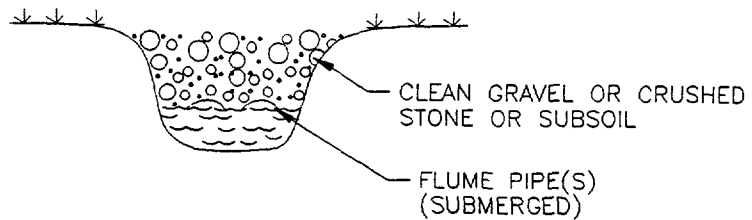

NOTE:

PORTABLE BRIDGES OR MATS MAY BE USED FOR EQUIPMENT CROSSING IF CONTOURS ALLOW.

BOLIVIA TO BRAZIL GAS PIPELINE (BOLIVIAN PORTION)

WET WATERBODY CROSSING  
(METHOD 1)

 **Dames & Moore**

FIGURE 10



**APPENDIX C**

**CONSTRUCTION SAFETY PLAN**

***BOLIVIA-BRAZIL GAS PIPELINE PROJECT***

## TABLE OF CONTENTS

1.0 SAFETY POLICY: .....	C-1
2.0 GENERAL INSTRUCTIONS: .....	C-1
3.0 RESPONSIBILITIES: .....	C-2
4.0 CONSTRUCTION SAFETY PROGRAM FOR CONTRACTORS AND SUBCONTRACTORS: .....	C-3
5.0 ACCIDENT PREVENTION: .....	C-5
6.0 HAZARD COMMUNICATION: .....	C-5
7.0 SAFETY TRAINING AND EDUCATION: .....	C-7
8.0 PERSONAL PROTECTIVE EQUIPMENT .....	C-7
A. FOOT PROTECTION .....	C-8
B. HEAD PROTECTION .....	C-8
C. HEARING PROTECTION .....	C-8
D. EYES AND FACE PROTECTION .....	C-8
9.0 FALL PROTECTION: .....	C-9
10.0 FIRST AID: .....	C-10
11.0 GOOD HOUSEKEEPING: .....	C-11
12.0 DRINKING WATER .....	C-11

13.0 SANITATION .....	C-12
14.0 OCCUPATIONAL NOISE EXPOSURE .....	C-12
15.0 RADIATION .....	C-14
A. IONIZING .....	C-14
B. NON-IONIZING RADIATION .....	C-14
16.0 ILLUMINATION.....	C-15
17.0 GASES, VAPORS, FUMES, DUSTS AND MISTS .....	C-16
18.0 VENTILATION .....	C-16
A. GENERAL .....	C-16
B. LOCAL EXHAUST VENTILATION .....	C-16
C. DESIGN AND OPERATION .....	C-16
D. DURATION OF OPERATION .....	C-17
E. DISPOSAL OF EXHAUST MATERIALS .....	C-17
19.0 RESPIRATOR PROTECTION .....	C-17
20.0 FIRE PROTECTION AND PREVENTION .....	C-19
A. FIRE PROTECTION .....	C-19
B. FIRE PREVENTION .....	C-20
21.0 FLAMMABLE AND COMBUSTIBLE LIQUIDS .....	C-23
22.0 SIGNS, SIGNALS AND BARRICADES .....	C-23
23.0 TOOLS - HAND AND POWER OPERATED .....	C-24

A. GENERAL REQUIREMENTS .....	C-24
B. HAND TOOLS .....	C-24
C. POWER-OPERATED HAND TOOLS .....	C-25
D. ABRASIVE WHEELS AND TOOLS .....	C-26
E. WOODWORKING TOOLS .....	C-26
F. JACKS-LEVER AND RATCHET, SCREW, AND HYDRAULIC ..	C-26
24.0 BLASTING AND THE USE OF EXPLOSIVES: .....	C-26
A. GENERAL .....	C-26
B. BLASTER QUALIFICATIONS .....	C-27
C. TRANSPORTATION OF EXPLOSIVES .....	C-28
D. STORAGE OF EXPLOSIVES AND BLASTING AGENTS .....	C-29
E. LOADING OF EXPLOSIVES .....	C-29
F. INITIATION OF EXPLOSIVE CHARGES - ELECTRIC BLASTING .....	C-30
G. USE OF SAFETY FUSE .....	C-32
H. USE OF DETONATING CORD .....	C-33
I. FIRING THE BLAST .....	C-33
J. INSPECTION AFTER BLASTING .....	C-34
K. MISFIRES .....	C-34
L. UNDER WATER BLASTING .....	C-34
25.0 WELDING .....	C-35
A. GAS WELDING AND CUTTING .....	C-35
B. ARC WELDING AND CUTTING .....	C-38
C. FIRE PREVENTION .....	C-40
D. VENTILATION AND PROTECTION IN WELDING, CUTTING AND HEATING .....	C-41

E. WELDING, CUTTING AND HEATING ON PRESERVATIVE COATINGS	C-43
26.0 RIGGING EQUIPMENT FOR MATERIAL HANDLING	C-44
A. GENERAL	C-44
B. ALLOY STEEL CHAINS	C-44
C. WIRE ROPE	C-44
27.0 AUTOMOTIVE EQUIPMENT:	C-46
A. GENERAL	C-46
B. TRANSPORTATION OF PERSONNEL	C-47
C. TRANSPORTATION OF MATERIALS	C-47
28.0 MATERIAL HANDLING EQUIPMENT	C-48
A. GENERAL	C-48
B. LIFTING EQUIPMENT	C-49
C. EARTHMOVING EQUIPMENT	C-51
D. PILE DRIVING EQUIPMENT	C-52
E. DITCHING MACHINES	C-53
F. BULLDOZERS	C-53
G. SIDEBOOMS AND TOW TRACTORS	C-54
H. FUELING OF EQUIPMENT	C-55
I. MAINTENANCE, REPAIRS, SERVICING	C-56
29.0 WORKING OVER OR NEAR WATER	C-57
A. PERSONNEL SAFETY	C-57
B. MATERIAL HANDLING OPERATIONS	C-57
C. WORKING SURFACES OR BARGES	C-58
30.0 CONSTRUCTION GUIDELINES	C-59
A. CLEARING AND GRADING	C-59

B. EXCAVATION AND SHORING .....	C-61
C. UNLOADING AND STRINGING PIPE .....	C-63
D. BENDING AND CUTTING .....	C-64
E. PIPE LAYING .....	C-64
F. CLEANING, COATING AND WRAPPING .....	C-65
G. LOWER-IN AND TIE-IN .....	C-65
H. BACKFILL AND CLEAN UP .....	C-66
I. ROADWAY AND RAILROAD CROSSINGS .....	C-66
J. UNLOADING AND SETTING MAINLINE VALVES .....	C-68
31.0 SPILL RESPONSE: .....	C-68

## TABLES

<u>No.</u>	<u>Description</u>
1	Recommended Eye and Face Protection
2	Sanitation Facilities
3	Permissible Noise Exposures
4	Selecting Laser Safety Glass
5	Minimum Illumination Intensities in Foot-Candles
6	Selection of Respirators
7	Fire Extinguisher Data
8	Number and Spacing of U-Bolt Wire Rope Clips

## FORMS

Incident Report Form

## **1.0 SAFETY POLICY:**

It is the policy of the Bolivia-Brazil Gas Pipeline Project Sponsors to conduct operations in a manner that protects the safety and health of employees, contractors and the general public. Accordingly, the project organization will:

- A. Comply fully with all applicable health and safety laws and regulations.
- B. Provide a professional staff to develop and support risk management activities and enforce adherence to safety rules and regulations.
- C. Endorse safety and health methods which will control human loss and protect the project's physical and financial resources.
- D. Rank safety and health equally with economic objectives.
- E. Consider safety, health, and environmental criteria in awarding contracts.
- F. Provide appropriate training for employees, contractors and subcontractors to ensure all personnel are properly trained in matters pertaining to health, safety, and protection of the environment.
- G. Assess progress toward safe systems and a safe and healthy work environment.
- H. Design facilities with high safety standards, and operate facilities with best safety and health practices.

## **2.0 GENERAL INSTRUCTIONS:**

These instructions have been prepared to inform all personnel, including employees, contractors and subcontractors of the safety requirements of the project and the rules governing the work to be performed. These instructions cannot cover every situation that will arise on a job. Accordingly, it will be necessary for all personnel to use good judgment and follow acceptable construction practices at all times.

The rules and regulations contained in this manual will be applicable to Project Sponsors' personnel as well as all contractors and subcontractors involved in the project.



### **3.0 RESPONSIBILITIES:**

All employees, contractors and subcontractors will share the responsibility for eliminating injuries, promoting maximum efficiency, and effecting savings by avoiding unplanned business interruptions from occupational accidents during construction. The effectiveness in accomplishing these goals will depend upon the participation and cooperation of construction management, supervisors, and employees, and the coordination of efforts in carrying out their assigned duties. All managers, supervisors and employees will be advised of their responsibilities and performance will be regularly measured. General responsibilities are summarized as follows:

#### **Managers/Supervisors**

- A. Plan all work to minimize personal injury, property damage and loss of productive time.
- B. Maintain a system for review and correction of procedures, practices and unsafe conditions.
- C. Make available and enforce the use of personal protective equipment and mechanical guards where required.
- D. Provide appropriate tools and establish an effective inspection and maintenance program for tools and equipment.
- E. Investigate all accidents to determine cause, and take prompt and necessary corrective action.
- F. Hold and document regular safety and environmental meetings.
- G. Communicate and enforce rules and minimum safety standards for employees and contractors.

#### **Employees**

- A. Comply with all rules, regulations and standards in performance of assigned duties.
- B. Participate in safety and environmental meetings.
- C. Report all incidents, injuries, and spills immediately.

- D. Assist in health, safety and environmental investigations.

### **Contractors**

- A. Ensure that all employees and subcontractors are properly trained in safety and health requirements of the project and their specific jobs.
- B. Comply with all project rules and local regulations.
- C. Report injuries, spills and accidents immediately to project management.
- D. Hold pre-job meetings and other safety meetings during the job.

## **4.0 CONSTRUCTION SAFETY PROGRAM FOR CONTRACTORS AND SUBCONTRACTORS:**

### **A. Contractor Record-keeping Requirements**

- 1. Maintain accurate injury and illness records.
- 2. Send Incident Report to Sponsor representative on-site.

### **B. Contractor and Subcontractor Safety and Health Responsibilities**

- 1. Designate an individual as Safety Inspector and First Aid Attendant.
- 2. Hold safety meetings for supervisors on a monthly basis. Include safety on agenda at all supervisor's meetings.
- 3. Hold employee safety orientations before work starts and periodically throughout the life of the project.
- 4. Personal protective equipment requirements:
  - a. Safety Shoes - Required based on job exposure.
  - b. Hard Hats - Required in all areas posted.
  - c. Eye Protection - Required, based on job exposure as determined by construction superintendent.
  - d. Hearing Protection - Required, based on job exposure as determined by construction superintendent.
  - e. Personnel Safety Harnesses - Required, based on job exposure as determined by construction superintendent.

- f. Respirators - Required, based on job exposure as determined by construction superintendent.
  - g. Welders' Helmets - Required, based on job exposure as determined by construction superintendent.
5. The construction chief or his designated representative will make a monthly inspection of contractor equipment.
6. Make accident investigations by contractor's representative for the following:
  - a. First Aid Injuries - Description, cause and prevention. Keep report form on-site.
  - b. Doctor's Care Injuries - Description, cause and prevention. Send report form to Sponsors' representative on the site.
  - c. Equipment Damage - Description, cause and prevention. Send report form to Sponsor representative on-site.
  - d. Forward copies of the Incident Report to Sponsor representative on-site.
7. Perform and document facility inspection of premises monthly by contractor and construction superintendent or designated representative.
8. Provide fire protection equipment with trained personnel. Test equipment monthly.
9. Post the following emergency telephone numbers:
  - a. Ambulance
  - b. Doctor
  - c. Hospital
  - d. Police
  - e. Fire Department
10. Require that safety review meetings be held with construction groups as needed (subcontractors) by construction chief or designated representative.
11. Require subcontractors to hold weekly tool box meetings for their employees.
12. Perform equipment inspections (personal protective equipment and hand tools) on a monthly basis.
13. Store flammable liquids in accordance with Section XXI of this Manual.
14. Erect scaffolds in accordance with applicable industry standards.
15. Use manufactured wood and/or metal ladders that are in proper working condition and suitable for the assigned task. The use of ladders with broken or missing rungs or steps, broken or split side rails, or other faulty or defective construction is prohibited.

16. Weld or use spark-producing devices for cutting or burning in accordance with Section XXV B. of this Manual.
17. Excavate, trench and shore in accordance with Section XXX B. of this Manual.
18. Develop emergency procedures pertaining to fire, medical assistance of equipment failure.
19. Give names and telephone numbers of contractor and subcontractor supervisors to Sponsor's on-site representative for posting in the Sponsor office.
20. Each contractor shall read, understand and use this construction safety manual as a basic minimum guideline for use in each respective operation.

## **5.0 ACCIDENT PREVENTION:**

- A. It shall be the responsibility of the contractor to initiate and maintain such programs as may be necessary to comply with project policies, applicable laws and regulations.
- B. Such programs shall provide for frequent and regular inspections of the job sites, materials and equipment to be made by competent persons designated by the employers.
- C. The use of any machinery, tool, material or equipment which is not in compliance with general industry construction safety standards is prohibited. Such machine, tool, material or equipment shall either be identified as unsafe by tagging and locking the controls to render them inoperable or shall be physically removed from its place of operation.
- D. The contractor shall permit only those employees qualified by training or experience to operate equipment and machinery.

## **6.0 HAZARD COMMUNICATION:**

- A. Multi-employer workplaces. Employers who produce, use, or store hazardous chemicals at a workplace in such a way that the employees of other employer(s) may be exposed (for example, employees of a construction contractor working on-site) shall additionally ensure that the hazard communication programs developed include the following:
  1. The methods the employer will use to provide the other employer(s) on-site access to material safety data sheets for each hazardous chemical the other employer(s)' employees may be exposed to while working;

2. The methods the employer will use to inform the other employer(s) of any precautionary measures that need to be taken to protect employees during the workplace's normal operating conditions and in foreseeable emergencies; and
  3. The methods the employer will use to inform the other employer(s) of the labeling system used in the workplace.
- B. Employers shall provide employees with effective information and training on hazardous chemicals in their work area at the time of their initial assignment, and whenever a new physical or health hazard the employees have not previously been trained about is introduced into their work area. Information and training may be designed to cover categories of hazards (e.g., flammability, carcinogenicity) or specific chemicals. Chemical-specific information must always be available through labels and material safety data sheets.
- C. Information. Employees shall be informed of:
1. Any operations in their work area where hazardous chemicals are present; and
  2. The location and availability of the written hazard communication program, including the required list(s) of hazardous chemicals, and material safety data sheets required by this section.
- D. Training. Employee training shall include at least:
1. Methods and observations that may be used to detect the presence or release of a hazardous chemical in the work area (such as monitoring conducted by the employer, continuous monitoring devices, visual appearance or odor of hazardous chemicals when being released, etc.);
  2. The physical and health hazards of the chemicals in the work area;
  3. The measures employees can take to protect themselves from these hazards, including specific procedures the employer has implemented to protect employees from exposure to hazardous chemicals, such as appropriate work practices, emergency procedures, and personal protective equipment to be used; and
  4. The details of the hazard communication program developed by the employer, including an explanation of the labeling system and the material safety data sheet, and how employees can obtain and use the appropriate hazard information.

## **7.0 SAFETY TRAINING AND EDUCATION:**

- A. The contractor shall instruct each employee in the recognition and avoidance of unsafe conditions and the regulations applicable to his or her work environment to control or eliminate any hazards or other exposure to illness or injury.
- B. Employees required to handle or use hazardous materials shall be instructed regarding the safe handling and use, and be made aware of the potential hazards, personal hygiene and personal protective measures required.
- C. In job site areas where harmful plants or dangerous animals are present, employees who may be exposed shall be instructed regarding the potential hazards, how to avoid injury and the first aid procedures to be used in the event of injury.
- D. All employees required to enter into confined or enclosed spaces shall be instructed as to the nature of the hazards involved, necessary precautions to be taken and the use of protective and emergency equipment required. The employer shall comply with any specific regulations that apply to work in dangerous or potentially dangerous areas.
- E. Every contractor must keep occupational injury and illness records for their employees in the establishment at which his employees usually report to work.
- F. Every contractor must maintain in each establishment:
  - 1. A log of recordable occupational injuries and illnesses.
  - 2. Supplementary records of each occupational injury or illness.
- G. Every contractor must keep records up to date, have them available to authorized government representatives or other authorities, and publish a summary of all occupational injuries and illnesses at the conclusion of the calendar year.
- H. To keep these records, the Incident Report Form must be completed.

## **8.0 PERSONAL PROTECTIVE EQUIPMENT:**

Contractors are responsible for requiring the wearing of appropriate personal protective equipment in all operations where there is an exposure to hazardous conditions.

#### A. FOOT PROTECTION

Safety shoes must be worn by employees exposed to potential foot hazards. Canvas or weave type shoes are not allowed on construction sites.

#### B. HEAD PROTECTION

Employees working in areas where there is a possible danger of head injury from impact or from falling or flying objects, or from electrical shock and burns, shall wear protective helmets.

#### C. HEARING PROTECTION

1. Whenever it is not feasible to reduce excessive noise levels or duration of exposure, hearing protective devices shall be provided.
2. Hearing protective devices inserted in the ear shall be fitted or determined individually by competent persons. Plain cotton is not an acceptable protective device.

#### D. EYES AND FACE PROTECTION

1. Employees shall be provided with eye and face protection equipment when machines or operations present potential eye or face injury from physical, chemical or radiation agents.
2. Employees whose vision requires the use of corrective lenses in spectacles shall be protected by goggles or spectacles of one of the following types:
  - a. Spectacles whose protective lenses provide optical correction.
  - b. Goggles that can be worn over corrective spectacles without disturbing the adjustment of the spectacles.
  - c. Goggles that incorporate corrective lenses mounted behind the protective lenses.
  - d. The following information shall be used as a guide in the selection of face and eye protection for the hazards and operations noted.

<b>TABLE 1 - Recommended Eye and Face Protection</b>		
<b>OPERATION</b>	<b>HAZARDS</b>	<b>RECOMMENDED PROTECTORS</b>
Acetylene - Burning Acetylene- Cutting Acetylene - Welding	Sparks, harmful rays, molten metal, flying particles	7,8,9

<b>TABLE 1 - Recommended Eye and Face Protection</b>		
<b>OPERATION</b>	<b>HAZARDS</b>	<b>RECOMMENDED PROTECTORS</b>
Chemical Handling	Splash, acid burns, fumes	2, 10 (For severe exposure add 10 over 2)
Chipping	Flying particles	1, 3, 4, 5, 6, 7A, 8A
Electric (arc) welding	Sparks, intense rays, molten metal	9, 11 (11 in combination with 4, 5, 6, in tinted lenses, advisable)
Grinding - Light	Flying particles	1, 3, 4, 5, 6, 10
Grinding - Heavy	Flying particles	1, 3, 7A, 8A (For severe exposure add 10)
Machining	Flying particles	1, 3, 4, 5, 6, 10
Molten metals	Heat, glare, sparks, splash	7, 8 (10 in combination with 4, 5, 6, in tinted lenses)
Spot welding	Flying particles, sparks	1, 3, 4, 5, 6, 10

Source: 29 CFR Part 1926

**Legend:**

- |   |   |
|---|---|
| 1. Goggles, flexible fitting, regular ventilation     | 7. Welding goggles, eyecup type, tinted lenses            |
| 2. Goggles, flexible fitting, hooded ventilation      | 7A. Chipping goggles, eyecup type, clear safety lenses    |
| 3. Goggles, cushioned fitting, rigid body             | 8. Welding goggles, coverspec type tinted lenses          |
| 4. Spectacles, metal frame, with side shields         | 8A. Chipping goggles, coverspec type, clear safety lenses |
| 5. Spectacles, plastic frame, with side shields       | 9. Welding goggles, coverspec type, tinted plate lens     |
| 6. Spectacles, metal-plastic frame, with side shields | 10. Face shield (Available with plastic or mesh window)   |
|   | 11. Welding helmets                                       |

**9.0 FALL PROTECTION:**

- A. Employees must wear approved fall protection at all times when working six feet or more above grade unless adequate alternate protection against falling is provided.
- B. Equipment requirements are:
  - 1. All harnesses shall be Class III full body safety harnesses.



2. When working from heights between two to five meters above grade, a lanyard without a deceleration device must be used.
  3. When working five meters or more above grade, a deceleration device is required between the lanyard and harness.
- C. Lanyards should be secured above the point of work being done whenever possible.
- D. Any anchor point that a lanyard or body harness safety line is attached to, must have a minimum breaking strength of 2,267.57 kg, or five times the live load. Steel cables are recommended for horizontal anchor lines.
- E. Safety harnesses or lanyards must be of a minimum 1.27 cm nylon or equivalent. Their normal breaking strength should be 2,267.57 kg.
- F. Lifelines attached to harnesses must be a minimum of 1.91 cm manila or equivalent, with a breaking strength of 2,267.57 kg.
- G. Each body harness and lanyard must be inspected before each use. Destroy and discard harness and lanyards that are worn or damaged.

## **10.0 FIRST AID:**

Provisions for prompt medical care and first aid services shall be made prior to commencement of the project for every employee. First aid is the immediate and temporary care given the victim of an accident or sudden illness until the services of a doctor can be obtained. Often an accident victim is hurt rather than helped by persons who want to do something, but do not know how to give first aid properly. Only people qualified in first aid should be permitted to attend an injured person. All construction crews shall be provided with a First Aid Kit, which shall be on the supply truck of the crew. A qualified first aid person shall be placed in charge of that particular kit.

- A. The First Aid Kit shall consist of material approved by a consulting physician in a weatherproof container with individual sealed packages for each type of item. The contents of the first aid kit shall be checked by the employer before being sent out on each job to ensure that any expended items have been replaced.
- B. Telephone numbers of physicians, hospital or ambulances shall be conspicuously posted.

- C. The foreman of each construction crew is responsible for first aid treatment and should have a person qualified to render first aid in his crew.
- D. An injured employee shall immediately report an injury to his foreman, regardless of how small.
- E. All accidents shall be reported to the field office by the foreman, and the foreman shall see that a proper accident report is made regarding this injury.

### **11.0 GOOD HOUSEKEEPING:**

Good housekeeping is the first law of accident prevention and shall be of primary concern to all construction personnel. Good housekeeping practices shall be planned at the beginning of the job by supervisory personnel and carefully supervised through the final clean up of the job.

- A. During the course of construction keep work areas clean of scrap and debris of all kinds.
- B. Rubbish debris, waste and useless materials constitute fire and accident hazards and shall be removed from the work area as fast as they accumulate. This applies in particular to field warehouse and field shop areas where operations remain at one place over a period of time. Machinery, particularly draglines and backhoes, should be checked to be sure all oil has been wiped off from areas where employees may step in order to prevent the employee from slipping on that surface.

### **12.0 DRINKING WATER:**

Typhoid fever, dysentery, cholera, and other diseases are often the result of contaminated drinking water and lack of proper sanitation on the job. Pipeline work requires the job to be constantly moving so the source of water supply is important.

- A. An adequate supply of potable water shall be provided in all work areas.
- B. Portable containers used to dispense drinking water shall be capable of being tightly closed, and equipped with a tap. Water shall not be dipped from the container.
- C. Any container used to distribute drinking water shall be clearly marked as to the nature of its contents and not used for any other purpose.

- D. The common drinking cup is prohibited.
- E. Where single service cups (to be used but once) are supplied, both a sanitary container for the unused cups and a receptacle for disposing of the used cups shall be provided.

**13.0 SANITATION:**

- A. Toilets at construction job sites shall be provided for personnel according to the following table.

<b>TABLE 2 - Sanitation Facilities</b>	
<b>Personnel</b>	<b>Minimum Number of Facilities</b>
20 or less	1 toilet seat
20 to 199	1 toilet seat and 1 urinal per 40 workers
200 or more	1 toilet seat and 1 urinal per 50 workers

**14.0 OCCUPATIONAL NOISE EXPOSURE:**

- A. Protection against the effects of noise exposure shall be provided when the sound levels exceed those shown in Table 3 of this section when measured on the A-scale of a standard sound level meter at slow response.
- B. When employees are subjected to sound levels exceeding those listed in Table 3 of this section, feasible administrative or engineering controls shall be utilized. If such controls fail to reduce sound levels within the levels of the table, personal protective equipment shall be provided and used to reduce sound levels within the levels of the table.
- C. If the variations in noise level reaches the maximum at intervals of 1 second or less, it is to be considered continuous.
- D. In all cases where the sound levels exceed the values shown herein, a continuing, effective hearing conservation program shall be administered.

TABLE 3 - Permissible Noise Exposures	
Duration per day, hours:	Sound level DB slow response
8	90
6	92
4	95
3	97
2	100
1-1/2	102
1	105
1/2	110
1/4 or less	115

- E. When the daily noise exposure is composed of two or more periods of noise exposure of different levels, their combined effect should be considered, rather than the individual effect of each. Exposure to different levels for various periods of time shall be computed according to the following formula:

$$Fe = \frac{T1}{L1} + \frac{T2}{L2} + \dots + \frac{Tn}{Ln}$$

Fe = The equivalent noise exposure factor

T = The period of noise exposure at any essentially constant level

L = The duration of the permissible noise exposure at the constant level (from Table 3)

If the value Fe exceeds unity (1) the exposure exceeds permissible levels.

- F. Exposure to impulsive or impact noise should not exceed 140 DB peak sound pressure level.

## 15.0 RADIATION:

### A. IONIZING

1. In construction and related activities involving the use of sources of ionizing radiation, the pertinent provisions of the Atomic Energy Commission's Standards for Protection against Radiation, relating to protection against occupational radiation exposure, shall apply.
2. Any activity which involves the use of radioactive materials or X-rays, shall be performed by competent persons especially trained in the proper and safe operation of such equipment.

### B. NON-IONIZING RADIATION

1. Only qualified and trained employees shall be assigned to install, adjust and operate laser equipment.
2. Proof of qualification of the laser equipment operator shall be available and in possession of the operator at all times.
3. Employees, when working in areas in which a potential exposure to direct or reflected laser light greater than 0.005 watts (5 milli-watts) exists, shall be provided with anti-laser eye protection devices. Table 4 provides guidelines for the proper selection of laser safety glass for worker eye protection.
4. Areas in which lasers are used shall be posted with standard laser warning placards.
5. Beam shutters or caps shall be utilized, or the laser turned off, when laser transmission is not actually required. When the laser is left unattended for a substantial period of time, such as during the lunch hour, overnight or at change of shifts, the laser shall be turned off.
6. Only mechanical or electronic means shall be used as a detector for guiding the internal alignment of the laser.
7. The laser beam shall not be directed at employees.
8. When it is raining or snowing, or when there is dust or fog in the air, the operation of laser systems shall be prohibited where practicable; in any event, employees shall be kept out of range of the area of source and target during such weather conditions.

TABLE 4 - Selecting Laser Safety Glass	
INTENSITY	ATTENUATION

<b>CW Maximum Power Density (Watts/cm<sup>2</sup>)</b>	<b>Optical Density (O.D.)</b>	<b>Attenuation Factor</b>
10.0	5	10
10.0	6	10
1.0	7	10
10.0	8	10

## 16.0 ILLUMINATION

Construction areas, corridors, offices, shops and storage areas shall be lighted to not less than the minimum illumination intensities listed in Table 5 while any work is in progress.

<b>TABLE 5 - Minimum Illumination Intensities in Foot-Candles</b>	
<b>Foot-Candles</b>	<b>Area of Operation</b>
5	General construction area lighting
3	General construction areas, concrete placement, excavation and waste areas, access-ways, active storage areas, loading platforms, refueling and field maintenance areas
5	Indoors; warehouse, corridors, hallways and exit-ways
5	Tunnels, shafts and general underground work areas; (Exception: minimum of 10 foot-candles is required at tunnel and shaft heading during drilling, mucking and scaling).
10	General construction plant and shops (e.g., batch plants, screening plants, mechanical and electrical equipment rooms, carpenter shops, rigging lofts and active storerooms, barracks or living quarters, locker or dressing rooms, mess halls, and indoor toilets and workrooms)
30	First aid stations, infirmaries and offices

## **17.0 GASES, VAPORS, FUMES, DUSTS AND MISTS:**

- A. Exposure of personnel to inhalation, ingestion, skin absorption or contact with any material or substance at a concentration above those which might be hazardous to human health shall be avoided.
- B. Administrative or engineering controls may be implemented if indicated. When such controls are not feasible, protective measures shall be used to keep the exposure of employees to air contaminants within acceptable limits. Any equipment and technical measures used for this purpose must first be approved for each particular use by a competent industrial hygienist or other technically qualified person. Whenever respirators are used, their use shall comply with Table 6 under Section XIX Respirator Protection.
- C. Paragraphs (A) and (B) of this section do not apply to the exposure of employees to airborne asbestos dust for which special regulations apply.

## **18.0 VENTILATION:**

### **A. GENERAL**

Whenever hazardous substances such as dust, fumes, mists, vapors or gases exist or are produced in the course of construction work, their concentrations shall not exceed the limits, which might be hazardous to human health. When ventilation is used as an engineering control method, the system shall be installed and operated according to the requirements of this section.

### **B. LOCAL EXHAUST VENTILATION**

Local exhaust ventilation when used as described in (A) shall be designed to prevent dispersion into the air of dusts, fumes, mists, vapors and gases in concentrations causing harmful exposure. Such exhaust systems shall be so designed that dusts, fumes, mists, vapors or gases are not drawn through the work area of employees.

### **C. DESIGN AND OPERATION**

Exhaust fans, jets, ducts, hoods, separators and all necessary appurtenances, including refuse receptacles, shall be so designed, constructed, maintained and operated as to ensure the required protection by maintaining a volume and velocity of exhaust air sufficient to gather dusts, fumes,

vapors or gases from said equipment or process, and to convey them to suitable points of safe disposal, thereby preventing their dispersion in harmful quantities into the atmosphere where employees work.

#### D. DURATION OF OPERATION

1. The exhaust system shall be in operation continually during all operations which it is designed to serve. If the employee remains in the contaminated zone, the system shall continue to operate after the cessation of said operations, the length of time depends upon the individual circumstances and effectiveness of the general ventilation system.
2. Since dust capable of causing disability is, according to the best medical opinion, of microscopic size, tending to remain for hours in suspension in still air, it is essential that the exhaust system be in continuous operation for a time after the work process or equipment served by the same shall have ceased, in order to ensure the removal of the harmful elements to the required extent. Employees wearing respiratory equipment should not remove the respirator until the atmosphere seems clear.

#### E. DISPOSAL OF EXHAUST MATERIALS

The air outlet from every dust separator, and the dusts, fumes, mists, vapors or gases collected by an exhaust or ventilation system shall discharge to the outside atmosphere. Collecting systems which return air to work areas may be used if concentrations which accumulate in the work area air do not result in harmful exposure to employees. Dust and refuse discharged from an exhaust system shall be disposed in such a manner that it will not result in harmful exposure to employees.

### 19.0 RESPIRATOR PROTECTION:

- A. In emergencies, or when controls are required to prevent harmful exposure to personnel appropriate respiratory protective devices shall be provided by the contractor and shall be used.
- B. Respiratory protective devices shall be those tested and certified by the National Institute for Occupational Safety and Health (NIOSH) and/or the Mine Safety and Health Administration (MSHA), or equivalent agency(ies), for the specific contaminant to which the employee is exposed.



- C. The chemical and physical properties of the contaminant, as well as the toxicity and concentration of the hazardous material, shall be considered in selecting the proper respirators.
- D. The nature and extent of the hazard, work requirements, and conditions, as well as the limitations and characteristics of the available respirators, shall also be factors considered in making the proper selection.
- E. Personnel required to use respiratory protective equipment shall be instructed in the use and limitations of such equipment.
- F. Personnel required to wear a respirator should have a lung function test to be sure they are physically capable to use one.
- G. All personnel subject to respirator protection must have a fit test conducted with the type of respirator they will be using.
- H. Respiratory protective equipment shall be inspected regularly and maintained in good condition. Gas mask canisters and chemical cartridges shall be replaced as necessary so as to provide complete protection. Mechanical filters shall be cleaned or replaced as necessary so as to avoid undue resistance to breathing.
- I. Respiratory protective equipment which has been previously used shall be cleaned and disinfected before it is issued by the contractor to another person. Emergency rescue equipment shall be cleaned and disinfected immediately after each use.
- J. The following table lists the types of respirators required for protection in dangerous atmospheres:

<b>TABLE 6 - Selection of Respirators</b>	
<b>Hazard</b>	<b>Respirator (See Note)</b>
Oxygen deficiency	Positive Pressure, Self-contained breathing apparatus. A combination airline respirator with auxiliary self-contained air supply or an air-storage receiver with alarm.

<b>TABLE 6 - Selection of Respirators</b>	
<b>Hazard</b>	<b>Respirator (See Note)</b>
Gas and vapor contaminants immediately dangerous to life and health.	Positive Pressure, Self-contained breathing apparatus. Self-rescue mouthpiece respirator (for escape only). Combination airline respirator with auxiliary self-contained air supply or an air-storage receiver with alarm.
Not immediately dangerous of life and health.	Airline respirator. Air-purifying, half-mask or mouthpiece respirator with chemical cartridge.
Particulate contaminants immediately dangerous to life and health.	Positive Pressure, Self-contained breathing apparatus. Self-rescue mouthpiece respirator (for escape only). Combination airline respirator with auxiliary self-contained air supply or an air-storage receiver with alarm.
Not immediately dangerous to life and health.	Air-purifying, half-mask or mouthpiece respirator with filter pad or cartridge. Airline respirator. Airline abrasive-blasting respirator.
Combination gas, vapor, and particulate contaminants immediately dangerous to life and health.	Positive Pressure, Self-contained breathing apparatus. Self-rescue mouthpiece respirator (for escape only). Combination air-line respirator with auxiliary self-contained air supply or an air-storage receiver with alarm.
Not immediately dangerous.	Airline respirator. Air-purifying, half-mask or mouthpiece respirator with chemical cartridge and appropriate filter.

Note: For the purpose of this part, "immediately dangerous to life and health" is defined as a condition that poses either an immediate threat to life and health or an immediate threat of severe exposure to contaminants, such as radioactive materials, which are likely to have adverse delayed effects on health.

## **20.0 FIRE PROTECTION AND PREVENTION:**

### **A. FIRE PROTECTION**

1. The contractor shall be responsible for the development and maintenance of an effective fire protection and prevention program at the job site throughout all phases of the construction work and shall ensure the availability of the fire protection and

- suppression equipment required.
2. Access to all available firefighting equipment shall be maintained at all times.
  3. All firefighting equipment shall be conspicuously located.
  4. All firefighting equipment shall be periodically inspected and maintained in operating condition. Defective equipment shall be immediately replaced.
  5. As warranted by the project, the contractor shall provide a trained and equipped firefighting organization (Fire Brigade) to assume adequate protection for life and property.
  6. Extinguishers and water drums, subject to freezing, shall be protected from freezing.
  7. A fire extinguisher, rated not less than 20 ABC, shall be provided within 15 meters of wherever more than 25 liters of flammable or combustible liquids or 3 kg of flammable gas are being used on the job site. This requirement does not apply to the integral fuel tanks of motor vehicles.
  8. Carbon tetrachloride and other toxic vaporizing liquid fire extinguishers are prohibited.
  9. Table 7 may be used as a guide for selecting the appropriate portable fire extinguishers.

<b>TABLE 7 - Fire Extinguishers Data</b>					
<b>Class</b>	<b>Water Type</b>	<b>Foam</b>	<b>Carbon Dioxide</b>	<b>Sodium or Potassium Bicarbonate</b>	<b>Multi-Purpose ABC</b>
<b>A</b> Wood, Paper, Trash Having Glowing Embers	YES	YES	NO	NO	YES
<b>B</b> Flammable Liquids, Gasoline, Oil, Paints, Grease, Etc.	NO	YES	YES	YES	YES
<b>C</b> Electrical Equipment	NO	NO	YES	YES	YES
<b>D</b> Combustible Metals			Special Extinguishing Agents Approved by Recognized Testing Laboratories		

Source: 29 CFR Part 1926

## B. FIRE PREVENTION

1. Electrical wiring and equipment for light, heat or power purposes shall be installed in compliance with the requirements of applicable country codes.

2. Smoking shall be prohibited at or in the vicinity of operations which constitute a fire hazard, and shall be conspicuously posted: "No Smoking or Unauthorized Ignition Sources."
3. Open Yard Storage.
  - a. Combustible materials shall be piled with due regard to the stability of piles and in no case higher than 6 meters.
  - b. Driveways between and around combustible storage piles shall be at least 5 meters wide and maintained free from rubbish, equipment, or other articles or materials. Driveways shall be so spaced that a maximum grid system of 15 meters by 45 meters is produced.
  - c. The entire storage site shall be kept free from accumulation of unnecessary combustible materials. Weeds and grass shall be kept down and a regular procedure provided for the periodic cleanup of the entire area.
  - d. Method of piling shall be solid wherever possible and in orderly and regular piles. No combustible material shall be stored outdoors within 3 meters of a building or structure.
  - e. Portable fire extinguishing equipment, suitable for the fire hazard involved, shall be provided at convenient, conspicuously accessible locations in the yard area. Portable fire extinguishers, rated not less than 2A, shall be placed so that maximum travel distance to the nearest unit shall not exceed 30 meters.
4. Indoor Storage.
  - a. Storage shall not obstruct, or adversely affect, means of exit.
  - b. All materials shall be stored, handled and piled with due regard to their fire characteristics.
  - c. Non-compatible materials, which may create a fire hazard, shall be segregated by a barrier having a fire resistance of at least 1 hour.
  - d. Materials shall be piled to minimize the spread of fire internally and to permit convenient access for firefighting. Stable piling shall be maintained at all times. Aisle space shall be maintained to safely accommodate the widest vehicle that may be used within the building for firefighting purposes.
  - e. Clearance of at least 1 meter shall be maintained between the top level of the stored material and sprinkler reflector.
  - f. Clearance shall be maintained around lights and heating units to prevent ignition of combustible materials.

- g. A clearance of 60 centimeters shall be maintained around the path of travel of fire doors unless a barricade is provided, in which case no clearance is needed. Material shall not be stored within 1 meter of a fire door opening.

## 5. Right-of-Way and Access Roads

The preservation of wildlife, vegetation and human resources is an important aspect of the endeavor. Following simple and effective methods of prevention and control by personnel operating equipment in the area will assure land preservation. The following requirements must be included as part of each employee's daily operation.

Due to the low amount of precipitation, drought conditions may be existent before and during the construction period. Help prevent the ignition source that could devastate the area by following these mandatory precautions:

- a. Catalytic mufflers on passenger cars and trucks are sources of ignition. Vehicle operators must be aware of the environment and not drive into a high grassy area unless the area has been cleared or wet down.
- b. Four wheel drive vehicles are preferred on the right-of-way because of the distance between the ground and the muffler.
- c. Exhaust and mufflers on trucks should be extended up the side of the vehicle, where possible.
- d. A major source of rangeland fires can be attributed to cigarettes being flipped out an open window. Avoid this habit and dispose of the cigarettes in the ashtray of the automobile in which you are riding.
- e. Right-of-Way and Access Roads. Fire extinguishers are to be carried in all vehicles that are required to be on the ROW where dry foliage conditions exist. 5# ABC units are preferred.
- f. Extreme caution must be taken while smoking on the ROW. Dispose of cigarettes or other smoking material in designated containers.
- g. No open fires will be allowed.
- h. Cooking on the ROW will not be allowed.
- i. Where designated parking areas exist, park only in these areas where the grass and other vegetation has been cut or wet down to avoid ignition.
- j. Should access continuously be required across high foliage areas and during dry conditions, four-wheel drive vehicles equipped with a 100 liter water tank and pressure pump must be available on the site.

## **21.0 FLAMMABLE AND COMBUSTIBLE LIQUIDS:**

- A. Only approved containers and portable tanks shall be used for storage and handling of flammable and combustible liquids. Approved metal safety cans shall be used for the handling and use of flammable liquids in quantities greater than one gallon, except that this shall not apply to those flammable liquid materials which are highly viscid (extremely hard to pour), which may be used and handled in original shipping containers. For quantities of one gallon or less, only the original container or approved metal safety cans shall be used for storage, use and handling of flammable liquids.
- B. Storage areas shall be kept free of weeds, debris and other combustible material not necessary to the storage.
- C. At least one portable fire extinguisher having a rating of not less than 20-ABC units shall be located not less than 8 meters, nor more than 24 meters, from any flammable liquid storage area located outside.
- D. At least one portable-fire extinguisher having a rating of not less than 20-ABC units shall be provided on all tank trucks or other vehicles used for transporting and/or dispensing flammable or combustible liquids.
- E. There shall be no smoking or unauthorized ignition sources in areas used for fueling, servicing fuel systems for internal combustion engines, receiving or dispensing of flammable or combustible liquids.
- F. Conspicuous and legible signs prohibiting smoking shall be posted.
- G. The motors of all equipment being fueled shall be shut off during the fueling operation.

## **22.0 SIGNS, SIGNALS AND BARRICADES:**

- A. Signs and symbols required for accident prevention shall be visible at all times when work is being performed, and shall be removed or covered promptly when the hazards no longer exist.
- B. Accident prevention tags shall be used as a temporary means of warning employees of an existing hazard, such as defective tools, equipment, etc.

- C. Construction areas shall be posted with visible and legible traffic signs at points of hazards.
- D. When operations are such that signs, signals and barricades do not provide the necessary protection on or adjacent to a highway or street, flaggers or other appropriate traffic controls shall be provided.
- E. Hand signaling by flaggers shall be by use of red flags at least 1/2 meter square or sign paddles, and in periods of darkness, red lights.
- F. Flaggers shall be provided with and shall wear a red or orange warning garment while flagging. Warning garments worn at night shall be of reflectorized material.
- G. The flaggers shall stand on the shoulder of the road next to the lane of traffic being controlled, NEVER on the road itself unless flaggers are behind barricades.
- H. Be sure the flaggers are far enough ahead of the place where the work is so motorists can slow down and stop safely.
- I. The flaggers should always face the traffic being controlled but be sure the flaggers can also see what is going on where the workers are working, or, if the flaggers cannot, they should have direct and continuous communication with the place where fellow workers are, such as two-way radio or telephone.

## **23.0 TOOLS - HAND AND POWER OPERATED:**

### **A. GENERAL REQUIREMENTS**

1. All hand and power tools and similar equipment, whether furnished by the contractor or the employee, shall be maintained in a safe condition.
2. When power operated tools are designed to accommodate guards, they shall be equipped with such guards when in use.

### **B. HAND TOOLS**

1. Contractors shall not issue or permit the use of unsafe hand tools.
2. Wrenches, including adjustable pipe, end and socket wrenches shall not be used when jaws are sprung to the point that slippage occurs.

3. Impact tools, such as drift pins, wedges and chisels, shall be kept free of mushroomed heads.
4. The wooden handles of tools shall be kept free of splinters or cracks and shall be kept tight in the tool.

#### C. POWER-OPERATED HAND TOOLS

1. Electric power operated tools shall either be of the approved double-insulated type or grounded.
2. Extension cords used with portable electric tools and appliances shall be of three-wire type.
3. The use of electric cords for hoisting or lowering tools shall not be permitted.
4. Pneumatic power tools shall be secured to the hose or whip by some positive means to prevent the tool from becoming accidentally disconnected.
5. All hoses exceeding 1 1/2 centimeter inside diameter shall have a safety device at the source of supply or branch line to reduce pressure in case of hose failure.
6. The fluid used in hydraulic powered tools shall be fire-resistant, and shall retain its operation characteristics at the most extreme temperatures to which it will be exposed.
7. The manufacturer's safe operating pressures for hoses, valves, pipe fittings and other fittings shall not be exceeded.
8. Only personnel who have been trained in the operation of Power-Actuated Tools shall be allowed to operate that particular tool.
9. The tool shall be inspected each day before loading to see that safety devices are in proper working condition.
10. Any tool found not in proper working order, or that develops a defect during use, shall be immediately removed from service and not used until properly repaired.
11. Tools shall not be loaded until just prior to the intended firing time. Neither loaded nor empty tools are to be pointed at any employees. Hands shall be kept clear of the open barrel end.
12. Loaded tools shall not be left unattended.
13. Tools shall not be used in an explosive or flammable atmosphere.
14. All tools shall be used with correct shields, guard or attachment recommended by the manufacturer.



#### D. ABRASIVE WHEELS AND TOOLS

1. All grinding machines shall be supplied with sufficient power to maintain the spindle speed at safe levels under all conditions of normal operation, and shall be equipped with safety guards.
2. Floor and bench-mounted grinders shall be provided with work rests which are rigidly supported and readily adjustable. Such work rests shall be kept at a distance not to exceed one-eighth from the surface of the wheel.
3. All employees using abrasive wheels shall be protected by eye protection equipment.

#### E. WOODWORKING TOOLS

1. All fixed power driven woodworking tools shall be provided with a disconnect switch that can either be locked or tagged in the off position.
2. All portable, power driven circular saws shall be equipped with guards above and below the base plate or shoe.

#### F. JACKS-LEVER AND RATCHET, SCREW, AND HYDRAULIC

1. The manufacturer's rated capacity shall be legibly marked on all jacks and shall not be exceeded.
2. All jacks shall have a positive stop to prevent overtravel.

### 24.0 BLASTING AND THE USE OF EXPLOSIVES:

#### A. GENERAL

1. The contractor shall permit only authorized and qualified persons to handle and use explosives.
2. Smoking, firearms, matches, open flame lamps, and other fires, flame or heat producing devices and sparks shall be prohibited in or near explosive magazines or while explosives are being handled, transported or used.
3. No person shall be allowed to handle or use explosives while under the influence of intoxicating liquors, narcotics, or other dangerous drugs.
4. All explosives shall be accounted for at all times. Explosives not being used shall be kept in a locked magazine, unavailable to persons not authorized to handle them. The contractor shall maintain an inventory and use record of all explosives. Appropriate authorities shall be notified of any loss, theft, or unauthorized entry into a magazine.

5. No explosives or blasting agents shall be abandoned.
6. No fire shall be fought where the fire is in imminent danger of contact with explosives. All personnel shall be removed to a safe area and the fire area guarded against intruders.
7. Original containers, or Class I magazines, shall be used for taking detonators and other explosives from storage magazines to be blasting area.
8. When blasting is done in congested areas or in proximity to a structure, railway, or highway, or any other installation that may be damaged,
  - a. the requisite authority to blast, if required, shall have been obtained.
  - b. the blaster shall take special precautions in the loading, delaying, initiation, and confinement of each blast with mats or other methods so as to control the throw of fragments, and thus prevent bodily injury to employees or damage to buildings, etc.
9. Personnel authorized to prepare explosive charges or conduct blasing operations shall use every reasonable precaution including, but not limited to, visual and audible warning signals, flags, or barricades, to ensure employee safety.
10. Blasting operations above ground shall be conducted between sunup and sundown.
11. Due precautions shall be taken to prevent accidental discharge of electricl blasting caps from current induced by radar, radio transmitters, lightning, adjacent power lines, dust storms, or other sources of extraneous electricity.
12. Empty boxes and paper and fibre packing materials, which have previously contained high explosives, shall not be used again for any purpose, but shall be destroyed by burning at an approved location.
13. Explosives, blasting agents, and blasting supplies that are obviously deteriorated or damaged shall not be used.
14. Delivery and issue of explosives shall only be made by and to authorized persons and into authorized magazines or approved temporary storage or handling areas.
15. Blasting operations in the proximity of overhead power line communication lines, utility services, or other services and structures shall not be initiated on until the operators and/or owners have been notified and measures for safe control have been taken.
16. The use of black powder shall be prohibited.
17. All loading and firing shall be directed and supervised by competent persons thoroughly experienced in this field.

## B. BLASTER QUALIFICATIONS

1. A blaster shall be able to understand and give written and verbal orders.

2. A blaster shall be in good physical condition and not be addicted to narcotics, intoxicants, or similar types of drugs.
3. A blaster shall be qualified, by reason of training, knowledge, or experience, in the field of transporting, storing, handling, and the use of explosives, and have a working knowledge of the laws and regulations which pertain to explosives in the country in which the work is being carried out.
4. Blasters shall be required to furnish satisfactory evidence of competency in handling explosives and performing in a safe manner the type of blasting that will be required.
5. The blaster shall be knowledgeable and competent in the use of each type of blasting method used.

### C. TRANSPORTATION OF EXPLOSIVES

1. Transportation of explosives shall meet the provisions of local regulations.
2. Motor vehicles or conveyances transporting explosives shall only be driven by, and be in the charge of, a licensed driver who is physically fit. He shall be familiar with local regulations governing the transportation of explosives.
3. No person shall smoke, or carry matches or any other flame producing device, nor shall firearms or loaded cartridges be carried while in or near a motor vehicle or conveyance transporting explosives.
4. Explosives, blasting agents, and blasting supplies shall not be transported with other materials or cargoes. Blasting caps (including electric) shall not be transported in the same vehicle with other explosives.
5. Vehicles used for transporting explosives shall be strong enough to carry the load without difficulty, and shall be in good mechanical condition.
6. When explosives are transported by a vehicle with an open body, a Class II magazine or original manufacturer's container shall be securely mounted on the bed to contain the cargo.
7. All vehicles used for the transportation of explosives shall have tight floors and any exposed spark-producing metal on the inside of the body shall be covered with wood, or other non-sparking material, to prevent contact with containers of explosives.
8. Every motor vehicle or conveyance used for transporting explosives shall be marked or placarded on both sides, the front, and the rear with the word "EXPLOSIVES" in red letters, not less than four inches in height, on white background. In addition to such marking or placarding, the motor vehicle or conveyance may display in such a manner that it will be readily visible from all directions, a red flag, 18 inches by 30 inches, with the word "EXPLOSIVES" painted, stamped, or sewn thereon, in white letters, at least six inches in height.

9. Each vehicle used for transportation of explosives shall be equipped with a fully charged fire extinguisher, in good condition. The driver shall be trained in the use of the extinguisher on his vehicle.
10. Motor vehicles or conveyances carrying explosives, blasting agents, or blasting supplies, shall not be taken inside a garage or shop for repairs or servicing.
11. No motor vehicle transporting explosives shall be left unattended.

#### D. STORAGE OF EXPLOSIVES AND BLASTING AGENTS

1. Explosives and related materials shall be stored in approved facilities.
2. Blasting caps, electric blasting caps, detonating primers, and primed cartridges shall not be stored in the same magazine with other explosives or blasting agents.
3. Smoking and open flames shall not be permitted within 30 meters of explosives and detonator storage magazine.

#### E. LOADING OF EXPLOSIVES

1. Procedures that permit safe and efficient loading shall be established before loading is started.
2. All drill holes shall be sufficiently large to admit freely the insertion of the cartridges of explosives.
3. Tamping shall be done only with wood rods or plastic tamping poles without exposed metal parts, but non-sparking metal connectors may be used for jointed poles. Violent tamping shall be avoided. The primer shall never be tamped.
4. No holes shall be loaded except those to be fired in the next round of blasting. After loading, all remaining explosives and detonators shall be immediately returned to an authorized magazine.
5. Drilling shall not be started until all remaining butts of old holes are examined for unexploded charges, and if any are found, they shall be refired before work proceeds.
6. No person shall be allowed to deepen drill holes which have contained explosives or blasting agents.
7. No explosives or blasting agents shall be left unattended at the blast site.
8. Machines and all tools not used for loading explosives into bore holes shall be removed from the immediate location of holes before explosives are delivered. Equipment shall not be operated within 50 feet of loaded holes.
9. No activity of any nature other than that which is required for loading holes with explosives shall be permitted in a blast area.

10. Power lines and portable electric cables for equipment being used shall be kept a safe distance from explosives or blasting agents being loaded into drill holes. Cables in the proximity of the blast area shall be de-energized and locked out by the blaster.
11. Holes shall be checked prior to loading to determine depth and conditions. Where a hole has been loaded with explosives but the explosives have failed to detonate, there shall be no drilling within 50 feet of the hole.
12. When loading a long line of holes with more than one loading crew, the crews shall be separated by practical distance consistent with efficient operation and supervision of crews.
13. No explosive shall be loaded or used underground in the presence of combustible gases or combustible dusts.
14. All blast holes in open work shall be stemmed to the collar or to a point which will confine the charge.
15. Warning signs, indicating a blast area, shall be maintained at all approaches to the blast area. The warning sign lettering shall not be less than four inches in height, RED on a contrasting background.
16. A bore hole shall never be sprung when it is adjacent to or near a hole that is loaded. Flashlight batteries shall not be used for springing holes.
17. Drill holes which have been sprung or chambered, and which are not water-filled, shall be allowed to cool before explosives are loaded.
18. No loaded holes shall be left unattended or unprotected.
19. The blaster shall keep an accurate, up to date record of explosives, blasting agents, and blasting supplies used in a blast and shall keep an accurate running inventory of all explosives and blasting agents stored on the operation.

#### F. INITIATION OF EXPLOSIVE CHARGES - ELECTRIC BLASTING

1. Electric blasting caps shall not be used where sources of extraneous electricity make the use of electric blasting caps dangerous. Blasting cap leg wires shall be kept short-circuited (shunted) until they are connected into the circuit for firing.
2. Before adopting any system of electrical firing, the blaster shall conduct a thorough survey for extraneous currents, and all dangerous currents shall be eliminated before any holes are loaded.
3. In any single blast using electric blasting caps, all caps shall be of the same style or function, and of the same manufacture.
4. Electric blasting shall be carried out by using blasting circuits or power circuits in accordance with the electric blasting cap manufacturer's recommendations, or an approved contractor or his designated representative.

5. When firing a circuit of electric blasting caps, care must be exercised to ensure that an adequate quantity of delivered current is available, in accordance with the manufacturer's recommendations.
6. Connecting wires and lead wires shall be insulated single solid wires of sufficient current carrying capacity.
7. Bus wires shall be solid single wires of sufficient current-carrying capacity.
8. When firing electrically, the insulation on all firing lines shall be adequate and in good condition.
9. A power circuit used for firing electric blasting caps shall not be grouted.
10. In underground operations when firing from a power circuit, a safety switch shall be placed in the permanent firing line at intervals. This switch shall be made so it can be locked only in the "Off" position and shall be provided with a short-circuiting arrangement of the firing lines to the cap circuit.
11. In underground operations there shall be a "lightning" gap of at least 1 1/2 meters in the firing system ahead of the main firing switch; that is, between the switch and the source of power. This gap shall be bridged by a flexible jumper cord just before firing the blast.
12. When firing from a power circuit, the firing switch shall be locked in the open or "Off" position at all times, except when firing. It shall be so designed that the firing lines to the cap circuit are automatically short-circuited when the switch is in the "Off" position. Keys to this switch shall be entrusted only to the blaster.
13. Blasting machines shall be in good condition and the efficiency of the machine shall be tested periodically to make certain that it can deliver power at its rated capacity.
14. When firing with blasting machines, the connections shall be made as recommended by the manufacturer of the electric blasting caps used.
15. The number of electric blasting caps connected to a blasting machine shall not be in excess of its rated capacity. Furthermore, in primary blasting, a series circuit shall contain no more caps than the limits recommended by the manufacturer of the electric blasting caps in use.
16. The blaster shall be in charge of the blasting machines, and no other person shall connect the leading wires to the machine.
17. Blasters, when testing circuits to charged holes, shall use only blasting galvanometers equipped with a silver chloride cell especially designed for this purpose.
18. Whenever the possibility exists that a leading line or blasting wire might be thrown over a live power line by the force of an explosion, care shall be taken to see that the total length of wires are kept too short to hit the lines, or that the wires are securely anchored to the ground. If neither of these requirements can be satisfied, a non-electric system shall be used.

19. In electrical firing, only the man making leading wire connections shall fire the shot. All connections shall be made from the bore hole back to the source of firing current, and the leading wires shall remain shorted and not be connected to the blasting machine or other source of current until the charge is to be fired.
20. After firing an electric blast from a blasting machine, the leading wires shall be immediately disconnected from the machine and short-circuited.

#### G. USE OF SAFETY FUSE

1. Safety fuses shall only be used where sources of extraneous electricity make the use of electric blasting caps dangerous. The use of a fuse that has been hammered or injured in any way shall be forbidden.
2. The hanging of a fuse on nails or other projections which will cause a sharp bend to be formed in the fuse is prohibited.
3. Before capping safety fuse, a short length shall be cut from the end of the supply reel so as to assure a fresh cut end in each blasting cap.
4. Only a cap crimper of an approved design shall be used for attaching blasting caps to safety fuse. Crimpers shall be kept in good repair and accessible for use.
5. No unused cap or short capped fuse shall be placed in any hole to be blasted; such unused detonators shall be removed from the working place and destroyed.
6. No fuse shall be capped, or primers made up, in any magazine or near any possible source of ignition.
7. No one shall be permitted to carry detonators or primers of any kind on his person.
8. The minimum length of safety fuse to be used in blasting shall be less than 75 centimeters.
9. At least two persons shall be present when multiple cap and fuse blasting is done by hand lighting methods.
10. Not more than 12 fuses shall be lit by each blaster when hand lighting devices are used. However, when two or more safety fuses in a group are lighted as one by means of igniter cord, or other similar fuse-lighting devices, they may be considered as one fuse.
11. The so-called "drop fuse" method of dropping or pushing a primer or any explosive with a lighted fuse attached is forbidden.
12. Cap and fuse shall not be used for firing mud cap charges unless charges are separated sufficiently to prevent one charge from dislodging other shots in the blast.
13. When blasting with safety fuses, consideration shall be given to the length and burning rate of the fuse. Sufficient time, with a margin of safety, shall always be provided for the blaster to reach a place of safety.

## H. USE OF DETONATING CORD

1. Care shall be taken to select a detonating cord consistent with the type and physical condition of the bore hole and the type of explosive used.
2. Detonating cord shall be handled and used with the same respect and care given other explosives.
3. The line of detonating cord extending out of a bore hole or from a charge shall be cut from the supply spool before loading the remainder of the bore hole or placing additional charges.
4. Detonating cord shall be handled and used with care to avoid damaging or severing the cord during and after loading and hooking-up.
5. Detonating cord connections shall be made in accordance with approved and recommended methods. Knot-type or other cord-to-cord connections shall be made only with detonating cord in which the explosive core is dry.
6. All detonating cord trunklines and branch lines shall be free of loops, sharp kinks, or angles that direct the cord back toward the oncoming line of detonation.
7. All detonating cord connections shall be inspected before firing the blast.
8. When detonating cord millisecond delay connectors or short interval delay electric blasting caps are used with detonating cord, the practice shall conform strictly to the manufacturer's recommendations.
9. When connecting a blasting cap or an electric blasting cap to detonating cord, the cap shall be taped or otherwise attached securely along the side or the end of the detonating cord, with the end of the cap containing the explosive charge pointed in the direction in which the detonation is to proceed.
10. Detonators for firing the trunk-line shall not be brought to the loading area nor attached to the detonating cord until everything else is in readiness for the blast.

## I. FIRING THE BLAST

1. A code of warning signals as set out in 4. below shall be posed on one or more conspicuous places at the operation, and all employees shall be required to familiarize themselves with the code and conform to it. Danger signs shall be placed at suitable locations.
2. Before a blast is fired, a loud warning signal shall be given by the blaster in charge, who has made certain that all surplus explosives are in a safe place and all personnel, vehicles and equipment are at a safe distance, or under cover.
3. Flaggers shall be safely stationed on highways which pass through the danger zone so as to stop traffic during blasting operations.



4. It shall be the duty of the blaster to fix the time of blasting.
  - a. Warning Signal. A 1 minute series of long audible warning signals 5 minutes prior to the blast signal and the waving of a red flag.
  - b. Blast Signal. A series of short audible warning signals 1 minute prior to the shot and the waving of a red flag.
  - c. All Clear Signal. A prolonged audible signal following the inspection of the blast area and the waving of a green flag.

#### J. INSPECTION AFTER BLASTING

1. Immediately after the blast has been fired, the firing line shall be disconnected from the blasting machine, or where power switches are used, they shall be locked open or in the off position.
2. Sufficient time shall be allowed, for the smoke and fumes to leave the blasted area before returning to the shot. An inspection of the area and the surrounding rubble shall be made by the blaster to determine if all charges have been exploded before personnel are allowed to return to the operation.

#### K. MISFIRES

1. If a misfire is found, the blaster shall provide proper safeguards excluding all personnel from the danger zone.
2. No other work shall be done except that necessary to remove the hazard of the misfire and only personnel necessary to do the work shall remain in the danger zone.
3. No attempt shall be made to extract explosives from any charged or misfired hole; a new primer shall be put in and the hole re-blasted. If re-firing of the misfired hole presents a hazard, the explosives may be removed by washing out with water or, where the misfire is under water, blown out with air.

#### L. UNDER WATER BLASTING

1. A blaster shall conduct all blasting operations, and no shot shall be fired without his approval.
2. Loading tubes and casings of dissimilar metals shall not be used because of possible electric transient currents from galvanic action of the metals and water.
3. Only water-resistant blasting caps and detonating cords shall be used for all marine blasting. Loading shall be done through a non-sparking metal loading tube when tube is necessary.

4. No blast shall be fired while any vessel under water is closer than 1,500 feet to the blasting area. Those on board vessels or craft moored or anchored within 1,500 feet shall be notified before a blast is fired.
5. No blast shall be fired while any swimming or diving operations are in progress in the vicinity of the blasting area. If such operations are in progress, signals and arrangements shall be agreed upon to assure that no blast shall be fired while any person is in the water.
6. Blasting Flags shall be displayed.
7. The storage and handling of explosives aboard vessels used in underwater blasting operations shall be according to provisions outlined herein on handling and storing explosives.
8. When more than one charge is placed under water, a float device shall be attached to an element of each charge in such manner that it will be released by the firing. Misfires shall be handled in accordance with provisions outlined herein on misfires.

## **25.0 WELDING:**

### **A. GAS WELDING AND CUTTING**

1. Transporting, moving and storing compressed gas cylinders.
  - a. Valve protection caps shall be in place and secured.
  - b. When cylinders are hoisted, they shall be secured on a cradle, sling board or pallet. They shall not be hoisted or transported by means of magnets or choker slings.
  - c. Cylinders shall be moved by tilting and rolling them on their bottom edges. They shall not be intentionally dropped, stuck or permitted to strike each other violently.
  - d. When cylinders are transported by powered vehicles, they shall be secured in a vertical position.
  - e. Valve protection caps shall not be used for lifting cylinders from one vertical position to another. Bars shall not be used under valves or valve protection caps to pry cylinders loose when frozen. Warm, not boiling, waters shall be used to thaw cylinders loose.
  - f. Unless cylinders are firmly secured on a special carrier intended for this purpose, regulators shall be removed and valve protection caps put in place before cylinders are moved.
  - g. Suitable cylinder truck, chain or other steadying device shall be used to keep cylinders from being knocked over while in use.
  - h. When work is finished, when cylinders are empty, or when cylinders are moved at any time, the cylinder valve shall be closed.

- i. Compressed gas cylinders shall be secured in an upright position at all times except, if necessary, for short periods of time while cylinders are actually being hoisted or carried.
  - j. Oxygen cylinders in storage shall be separated from fuel gas cylinders or combustible materials (especially oil or grease), a minimum distance of six meters or by a non-combustible barrier at least 1 1/2 meters high having a fire-resistance rating of at least one half hour.
2. Placing cylinders.
    - a. Cylinders shall be kept far enough away from the actual welding or cutting operation so that sparks, hot slag or flame will not reach them. When this is impractical, fire resistant shields shall be provided.
    - b. Cylinders shall be placed where they cannot become part of an electrical circuit. Electrodes shall not be struck against a cylinder to strike an arc.
    - c. Fuel gas cylinders shall be placed with valve end up whenever they are in use. They shall not be placed in a location where they would be subject to open flame, hot metal or other sources of artificial heat.
    - d. Cylinders containing oxygen or acetylene or other fuel gas shall not be taken into confined spaces.
  3. Treatment of cylinders.
    - a. Cylinders, whether full or empty, shall not be used as rollers or supports.
    - b. No person other than the gas supplier shall attempt to mix gases in a cylinder. No one except the owner of the cylinder or person authorized by owner, shall refill a cylinder. No one shall use a cylinder's contents for purposes other than those intended by the supplier.
    - c. No damaged or defective cylinder shall be used.
  4. Use of fuel gas. The contractor shall thoroughly instruct personnel in the safe use of fuel gas, as follows:
    - a. Before a regulator to a cylinder valve is connected, the valve shall be opened slightly and closed immediately. (This action is generally termed "cracking" and is intended to clear the valve of dust or dirt that might otherwise enter the regulator.) The person cracking the valve shall stand to one side of the outlet, not in front of it. The valve of a fuel gas cylinder shall not be cracked where the gas would reach welding work, sparks, flame or other possible sources of ignition.
    - b. The cylinder valve shall always be opened slowly to prevent damage to the regulator. For quick closing, valves on fuel gas cylinders shall not be opened more than 1-1/2 turns. When a special wrench is required, it shall be left in position on the stem of the valve while the cylinder is in use so that the fuel gas flow can be shut off quickly in case of an emergency. In the case of manifolded or coupled cylinders, at least one such

wrench shall always be available for immediate use. Nothing shall be placed on top of a fuel gas cylinder, when in use, which may damage the safety device or interfere with the quick closing of the valve.

- c. Fuel gas shall not be used from cylinders through torches or other devices which are equipped with shutoff valves without reducing the pressure through a suitable regulator attached to the cylinder valve or manifold.
- d. Before a regulator is removed from a cylinder valve, the cylinder valve shall always be closed and the gas released from the regulator.
- e. If, when the valve on a fuel gas cylinder is opened, there is found to be a leak around the valve stem, the valve shall be closed and the gland nut tightened. If this action does not stop the leak, the use of the cylinder shall be discontinued, and it shall be properly tagged and removed from the work area. In the event that fuel gas should leak from the cylinder valve, rather than from the valve stem, and the gas cannot be shut off, the cylinder shall be properly tagged and removed from the work area. If a regulator attached to a cylinder valve will effectively stop a leak through the valve seat, the cylinder need not be removed from the work area.
- f. If a leak should develop at a fuse plug or other safety device, the cylinder shall be removed from the work area.

5. Hose.

- a. Fuel gas hose and oxygen hose shall be easily distinguishable from each other. The contrast may be made by different colors or by surface characteristics readily distinguishable by the sense of touch. Oxygen and fuel gas hoses shall not be interchangeable. A single hose having more than one gas passage shall not be used.
- b. When parallel sections of oxygen and fuel gas hose are taped together, not more than 10 centimeters out of 30 centimeters shall be covered by tape.
- c. All hoses in use, carrying acetylene, oxygen, natural or manufactured fuel gas, or any gas or substance which may ignite or enter into combustion, or be in any way harmful to personnel, shall be inspected at the beginning of each working shift. Defective hose shall be removed from service.
- d. Hose which has been subject to flashback, or which shows evidence of severe wear or damage, shall be tested to twice the normal pressure to which is it subject, but in no case less than 300 p.s.i. Defective hose, or hose in doubtful condition shall not be used.
- e. Hose couplings shall be of the type that cannot be unlocked or disconnected by means of a straight pull without rotary motion.
- f. Boxes used for the storage of gas hose shall be ventilated.
- g. Hoses, cables and other equipment shall be kept clear of passageways, ladders and stairs.

6. Torches.
  - a. Clogged torch tip openings shall be cleaned with suitable cleaning wires, drills or other devices designed for such purposes.
  - b. Torches in use shall be inspected at the beginning of each working shift for leaking shutoff valves, hose couplings and tip connections. Defective torches shall not be used.
  - c. Torches shall be lighted by friction lighters or other approved devices, and not by matches or from hot work.
7. Regulators and gauges.

Oxygen and fuel gas pressure regulator, including their related gauges, shall be in proper working order while in use.
8. Oil and grease hazards.

Oxygen cylinders and fittings shall be kept away from oil or grease. Cylinders, cylinder caps and valves, couplings, regulators, hose and apparatus shall be kept free from oil or greasy substances and shall not be handled with oily hands or gloves. Oxygen shall not be directed at oily surfaces, greasy clothes, or storage tank or vessel.

## B. ARC WELDING AND CUTTING

1. Manual electrode holders.
  - a. Only manual electrode holders which are specifically designed for arc welding and cutting, and are of a capacity capable of safely handling the maximum rated current required by the electrodes, shall be used.
  - b. Any current-carrying parts passing through the portion of the holder which the arc welder or cutter grips in their hand, and the outer surfaces of the jaws of the holder, shall be fully insulated against the maximum voltage encountered to ground.
2. Welding cables and connectors.
  - a. All arc welding and cutting cables shall be of the completely insulated, flexible type, capable of handling the maximum current requirements of the work in progress, taking into account the duty cycle under which the arc welder or cutter is working.
  - b. Only cable free from repair or splices for a minimum distance of three meters from the cable end to which the electrode holder is connected shall be used, except that cables with standard insulated connectors or with splices whose insulating quality is equal to that of the cable are permitted.
  - c. When it becomes necessary to connect or splice lengths of cable one to another, substantial insulated connectors of a capacity at least equivalent to that of the

- cable shall be used. If connections are effected by means of cable lugs, they shall be securely fastened together to give good electrical contact, and the exposed metal parts of the lugs shall be completely insulated.
- d. Cables in need of repair shall not be used. When a cable, other than the cable lead referred to in Subparagraph (B) of this section, becomes worn to the extent of exposing bare conductors, the portion thus exposed shall be protected by means of rubber and friction tape or other equivalent insulation.
3. Ground returns and machine grounding.
    - a. A ground return cable shall have a safe current carrying capacity equal to or exceeding the specified maximum output capacity of the arc welding or cutting unit which it services. When a single ground return cable services more than one unit, its safe current-carrying capacity shall equal or exceed the total specified maximum output capacities of all the units which it services.
    - b. Pipelines containing gases or flammable liquids, or conduits containing electrical circuits, shall not be used as a ground return.
    - c. When a structure or pipeline is employed as a ground return circuit, it shall be determined that the required electrical contact exists at all joints. The generation of an arc, sparks or heat at any point shall cause rejection of the structures as a ground circuit.
    - d. When a structure or pipeline is continuously employed as a ground return circuit, all joints shall be bonded, and periodic inspections shall be conducted to ensure that no condition of electrolysis or fire hazard exist by virtue of such use.
    - e. The frames of all arc welding and cutting machines shall be grounded either through a third wire in the cable containing the circuit conductor or through a separate wire which is grounded at the source of the current. Grounding circuits, other than by means of the structure, shall be checked to ensure that the circuit between the ground and the grounded power conductor has resistance low enough to permit sufficient current to flow to cause the fuse or circuit breaker to interrupt the current.
    - f. All ground connections shall be inspected to ensure that they are mechanically strong and electrically adequate for the required current.
  4. Operating Instructions. Contractors shall instruct personnel in the safe means of arc welding and cutting as follows:
    - a. When electrode holders are to be left unattended, the electrodes shall be removed and the holders shall be so placed or protected that they cannot make electrical contact with personnel or conducting objects.
    - b. Hot electrode holders shall not be dipped in water, to do so may expose the arc welder or cutter to electric shock.

- c. When the arc welder or cutter has occasion to leave their work or to stop work for any appreciable length of time, or when the arc welding or cutting machine is to be moved, the power supply switch to the equipment shall be opened.
  - d. Any faulty or defective equipment shall be reported to the supervisor.
5. Shielding.
- a. Whenever practicable, all arc welding and cutting operations shall be shielded by noncombustible or flameproof screens which will protect employees and other persons working in the vicinity from the direct rays of the arc.

### C. FIRE PREVENTION

1. When practical, objects to be welded, cut or heated shall be moved to a designated safe location or, if the objects to be welded, cut or heated cannot be readily moved, all movable fire hazards in the vicinity shall be taken to a safe place, or otherwise protected.
2. If the object to be welded, cut or heated cannot be moved and if all the fire hazards cannot be removed, positive means shall be taken to confine the heat, sparks, and slag, and to protect the immovable fire hazards from them.
3. No welding, cutting or heating shall be done where the application of flammable paints, or the presence of other flammable compounds, or heavy dust concentrations create a hazard.
4. Suitable fire extinguishing equipment shall be immediately available in the work area and shall be maintained in a state of readiness for instant use.
5. When the welding, cutting or heating operation is such that normal fire prevention precautions are not sufficient, additional personnel shall be assigned to guard against fire while the actual welding, cutting or heating operation is being performed, and for a sufficient period of time after completion of the work to ensure that no possibility of fire exists. Such personnel shall be instructed as to the specific anticipated fire hazards and how the firefighting equipment provided is to be used.
6. Drums, containers or hollow structures which have contained toxic or flammable substances shall, before welding, cutting or heating is undertaken on them, either be filled with water or thoroughly cleaned of such substances and ventilated and tested.
7. Before heat is applied to a drum, container or hollow structure, a vent or opening shall be provided for the release of any built-up pressure during the application of heat.

## D. VENTILATION AND PROTECTION IN WELDING, CUTTING AND HEATING

1. Mechanical Ventilation: For purposes of this section, mechanical ventilation shall meet the following requirements:
  - a. Mechanical ventilation shall consist of either general mechanical ventilation systems or local exhaust systems.
  - b. General mechanical ventilation shall be of sufficient capacity and so arranged as to produce the number of air changes necessary to maintain welding fumes and smoke within safe limits, as defined in the section under ventilation.
  - c. Local exhaust ventilation shall consist of freely movable hoods intended to be placed by the welder or burner as close as practicable to the work. This system shall be of sufficient capacity and so arranged as to remove fumes and smoke at the source and keep the concentration of them in the breathing zone within safe limits, as defined in the section under ventilation.
  - d. Contaminated air exhausted from a working space shall be discharged into the open air or otherwise clear of the source of intake air.
  - e. All air replacing that withdrawn shall be clean and respirable.
  - f. Oxygen shall not be used for ventilation purposes, comfort cooling, blowing dust from clothing or for cleaning the work area.
2. Welding, cutting and heating in confined spaces.
  - a. Except as provided in Subparagraph (b) of this paragraph either general mechanical or local exhaust ventilation meeting the requirements of Paragraph (A) of this section shall be provided whenever welding, cutting or heating is performed in a confined space.
  - b. When sufficient ventilation cannot be obtained without blocking the means of access, employees in the confined space shall be protected by airline respirators and an employee on the outside of such a confined space shall be assigned to maintain communication with those working within it and to aid them in an emergency.
  - c. Where a welder must enter a confined space through a manhole or other small opening, means shall be provided for quickly removing him in case of emergency. When safety belts and lifelines are used for this purpose, they shall be so attached to the welder's body that his body cannot be jammed in a small exit opening. An attendant with a pre-planned rescue procedure shall be stationed outside to observe the welder at all times and be capable of putting rescue operations into effect.
3. Welding, cutting, or heating of metals of toxic significance



- a. Welding, cutting, or heating in any enclosed spaces involving zinc-bearing base or filler metals, or metals coated with zinc-bearing materials; lead base metals; cadmium-bearing filler materials; or chromium-bearing metals or metals coated with chromium-bearing materials shall be performed with either general mechanical or local exhaust ventilation meeting the requirements of Paragraph A of this section.
  - b. Welding, cutting, or heating in any enclosed spaces involving metals containing lead, other than as an impurity, or metals coated with lead-bearing materials; cadmium-bearing or cadmium-coated base metals; metals coated with mercury-bearing materials; or beryllium-containing base or filler metals shall be performed with local exhaust ventilation in accordance with the requirements or paragraph A of this section, or employees shall be protected by air line respirators. Because of its high toxicity, work involving beryllium shall be done with both local exhaust ventilation and air line respirators.
  - c. Employees performing such operations in the open air shall be protected by filter-type respirators in accordance with the requirements of Section XIX of this part, except that employees performing such operations on beryllium-containing base or filler metals shall be protected by air line respirators.
  - d. Other employees exposed to the same atmosphere as the welders or burners shall be protected in the same manner as the welder or burner.
4. Inert-Gas Metal-Arc Welding.
- a. Since the inert-gas metal-arc welding process involves the production of ultraviolet radiation of intensities of 5 to 30 times higher than that produced during shielded metal-arc welding, the decomposition of chlorinated solvents by ultraviolet rays, and the liberation of toxic fumes and gases, employees shall not be permitted to engage in, or be exposed to the process until the following special precautions have been taken:
    - 1) The use of chlorinated solvents shall be kept at least 60.6 meters unless shielded, from the exposed arc, and surfaces prepared with chlorinated solvents shall be thoroughly dry before welding is permitted on such surfaces.
    - 2) Employees in the area not protected from the arc by screening shall be protected by filter lenses meeting the requirements under eye protection of this Manual. When two or more welders are exposed to each other's arc, filter lens goggles of a suitable type, meeting the requirements of eye protection of this Manual shall be worn under welding helmets. Hand shields to protect the welder against flashes and radiant energy shall be used when either the helmet is lifted or the shield is removed.

- 3) Welders and other personnel who are exposed to radiation shall be suitably protected so that the skin is covered completely to prevent burns and other damage by ultraviolet rays. Welding helmets and hand shields shall be free of leaks and openings, and free of highly reflective surfaces.
  - b. When inert gas metal-arc welding is being performed on stainless steel, the requirements of paragraph 3.B. above shall be met to protect against dangerous concentrations of nitrogen dioxide.
5. General welding, cutting and heating.
  - a. Welding, cutting and heating, not involving conditions described in Paragraph (2) or (3) of this section, may normally be done without mechanical ventilation or respiratory protective equipment, but where, because of unusual physical or atmospheric conditions, an unsafe accumulation of contaminants exists, suitable mechanical ventilation or respiratory protective equipment shall be provided.
  - b. Personnel performing any type of welding, cutting or heating shall be protected by suitable eye protective equipment.
  - c. Necessary precautions shall be taken by the welder to protect their ears when welding in a bellhole.
  - d. Eye protection shall be worn by all personnel doing any buffing or grinding work.
  - e. Welding trucks shall be equipped with approved fire extinguishers, first aid materials, etc.

#### E. WELDING, CUTTING AND HEATING ON PRESERVATIVE COATINGS

1. Before welding, cutting or heating is commenced on any surface covered by a preservative coating whose flammability is not known, a test shall be made by a competent person to determine its flammability. Preservative coatings shall be considered to be highly flammable when scrapings burn with extreme rapidity.
2. Precautions shall be taken to prevent ignition of highly flammable hardened preservative coatings. When coatings are determined to be flammable, they shall be stripped from the area to be heated to prevent ignition.
3. Protection against toxic preservative coatings.
  - a. In enclosed spaces, all surfaces covered with toxic preservatives shall be stripped of all toxic coatings for a distance of at least 4 inches from the area of heat application, or the employees shall be protected by airline respirators.
  - b. In the open air, personnel shall be protected by a respirator, in accordance with requirements of Table 6 of this Manual (Section XIX).
4. The preservative coatings shall be removed a sufficient distance from the area to be heated to ensure that the temperature of the unstripped metal will not be appreciably

raised. Artificial cooling of the metal surrounding the heating area may be used to limit the size of the area required to be cleaned.

## **26.0 RIGGING EQUIPMENT FOR MATERIAL HANDLING:**

### **A. GENERAL**

1. Rigging equipment for material handling shall be inspected prior to use on each shift and as necessary during its use to ensure that it is safe. Defective rigging equipment shall be removed from service.
2. Rigging equipment shall not be loaded in excess of its recommended safe working load.
3. Rigging equipment, when not in use, shall be removed from the immediate work area so as not to present a hazard to personnel.
4. Special custom design grabs, hooks, clamps, or other lifting accessories, shall be marked to indicate the safe working loads and shall be proof-tested prior to use to 125 percent of their rated load.

### **B. ALLOY STEEL CHAINS**

1. Welded alloy steel chain slings shall have permanently affixed durable identification stating size, grade, rated capacity and sling manufacturer.
2. Hooks, rings, oblong links, pear-shaped links, welded or mechanical coupling links, or other attachments, when used with alloy steel chains, shall have a rated capacity at least equal to that of the chain.
3. Job or shop hooks and links, or makeshift fasteners, formed from bolts, rods, etc., or other such attachments, shall not be used.
4. Rated capacity (work load limits) for alloy steel chain slings shall conform to the specified standard and/or manufacturer's recommendations.
5. Whenever wear at any point of any chain link exceeds that set out in the specified standard and/or manufacturer's recommendations, the assembly shall be removed from service.

### **C. WIRE ROPE**

1. Refer to the manufacturer's recommendations as to the safe working loads, classifications, and grades for steel wire rope and slings with various terminations. The safe working load recommended by the manufacturer shall be followed, provided that a safety factor of not less than 5 is maintained.

2. Protruding ends of strands in splices on slings and bridles shall be covered or blunted.
3. Wire rope shall not be secured by knots.
4. The following limitations shall apply to the use of wire rope:
  - a. An eye splice made in any wire rope shall have not less than four full tucks. However, this requirement shall not operate to preclude the use of another form of splice or connection which can be shown to be as efficient and which is not otherwise prohibited.
  - b. Except for eye splices in the ends of wires and for endless rope slights, each wire rope used in hoisting or lowering, or in pulling loads, shall consist of one continuous piece without knot or splice.
  - c. Eyes in wire rope bridles, slings or bull wires shall not be formed by wire rope clips or knots.
  - d. Wire rope shall not be used if, in any length of eight diameters, the total number of visible broken wires exceeds 10 percent of the total number of wires, or if the rope shows other signs of excessive wear, corrosion or defect.
  - e. When U-Bolt wire rope clips are used to form eyes, the following table shall be used to determine the number and spacing of clips.

<b>TABLE 8</b>			
<b>Number and Spacing of U-Bolt Wire Rope Clips</b>			
<b>Number of Clips</b>			
Improved plow steel, rope diameter inches	Drop forged	Other material	Minimum spacing (inches)
1/2	3	4	3
5/8	3	4	3 3/4
3/4	4	5	4 1/2
7/8	4	5	5 1/4
1	5	6	6
1 1/8	6	6	6 3/4
1 1/4	6	7	7 1/2
1 3/8	7	7	8 1/4
1 1/2	7	8	9

- f. When used for eye splices, the U-Bolt shall be applied so that the "U" section is in contact with the dead end of the rope.

## **27.0 AUTOMOTIVE EQUIPMENT:**

### **A. GENERAL**

1. No contractor shall allow the use of any motor vehicle equipment having an obstructed view to the rear unless:
  - a. The vehicle has a reverse signal alarm audible above the surrounding noise level or;
  - b. The vehicle is backed up only when an observer signals that it is safe to do so.
2. All vehicles in use shall be inspected at the beginning of each shift to assure that the following parts, equipment and accessories are in safe operating condition and free of apparent damage that could cause failure while in use: service brakes, including trailer brake connections; parking system (hand brakes); emergency stopping system (brakes); tires; horn; steering mechanism; coupling devices; seat belts; operating controls; and safety devices. All defects shall be corrected before the vehicle is placed in service. These requirements also apply to equipment such as lights, reflectors, windshield wipers, defroster, fire extinguishers, etc., where such equipment is necessary.
3. The winch-block used on trucks or tractors shall have a safety bridle on the hook.
4. Cables and hoisting equipment shall be inspected daily. Damaged cable or hoisting equipment shall be replaced or repaired immediately.
5. The use or possession of alcoholic beverages on company property or during work hours is strictly prohibited.
6. Never stop in the center of the road. Always pull over to one side before stopping. If a breakdown occurs at night and the vehicle lights go out, protect the truck with appropriate signals until aid is secured.
7. Before stopping or attempting to turn, always give proper signal to vehicle approaching from rear.
8. The driver should look both ways before crossing railroad tracks, and should put the truck in low until the tracks are crossed.
9. The driver must stop and look in both directions before driving onto a major highway from a minor road.

10. The driver shall slow down and sound horn of the vehicle when approaching a blind curve.
11. Drive as close to the right-hand side of the road as safety permits.
12. Do not fail to slow down the moment children are seen on the sidewalk or roadway. Drivers must stop when school buses are loading or unloading children.
13. Keep rear view mirror in good condition and use it for purposes intended. Make it as easy as possible for the approaching traffic to pass. Do not monopolize the highway.
14. The drivers of all trucks loaded with employees or materials, when starting down a steep hill shall shift gears to such a position as is necessary to insure complete control.
15. Truck and car drivers shall report all accidents involving personal injury or property damage to their supervisor immediately.
16. All trucks operating in a convoy shall travel a minimum of 100 meters apart.
17. All truck drivers shall be responsible for the safety of employees on their trucks, for compliance with safety regulations and for speed limits set by host country laws.

#### B. TRANSPORTATION OF PERSONNEL

1. Vehicles used to transport personnel shall have seats firmly secured and adequate for the number of employees to be carried.
2. Seat belts shall be installed and worn in all motor vehicles.
3. Tools and materials shall be secured to prevent movement when transported in the same compartment with personnel.
4. Personnel shall not ride with their arms or legs outside of the truck body, in standing position, on running boards, seated on fenders, or seated on or in trucks with loads.
5. The driver of a crew truck shall require that personnel not unload until the truck has come to a complete stop.
6. Truck drivers shall not drive faster than the speed prescribed by the local laws and shall have the vehicle under control at all times.
7. Drivers must not permit non-employees to operate company equipment or vehicles.
8. No flammable liquids or loose materials of any kind shall be permitted in the compartment where people are riding.

#### C. TRANSPORTATION OF MATERIALS

1. All pipe loads shall be boomed with not less than three chains, and the chains shall not be less than 1 centimeter, good quality, with adequate strength for application. Loose end of boomer chains shall not be allowed to drag. Boomer handles shall be operated

from the ground and on the right side of the vehicle. Employees should never stand over a boomer when releasing or taking up on loads.

2. All haulage vehicles, whose pay load is loaded by means of cranes, power shovels, loaders or similar equipment, shall have a cab shield and/or canopy adequate to protect the operator from shifting or falling materials.
3. Operating levers controlling hoisting or dumping devices on haulage bodies shall be equipped with a latch or other device which will prevent accidental starting or tripping of the mechanism.
4. Leather or leather-palm gloves shall be worn by employees when unloading pipe.
5. The load shall be examined carefully to see that stakes on both sides of the truck or wagon bed are securely set to prevent pipe from rolling when the boomers are released.
6. A power line pole should not be used as a snub for a winch when materials are moved or truck is pulled when stuck, as there is a danger of shorting the wires when the strain is taken off the pole.
7. Skids shall be properly placed when handling pipe or heavy materials.
8. Hooks or calipers on "A" frame of trucks shall be securely fastened to prevent swinging when not in use. Never stand under "A" frame.
9. Trailers being pulled by king pins shall have a safety chain of sufficient size to hold load should the king pin break.
10. Materials shall be properly loaded to prevent shifting or falling while in transit.
11. Loads extending beyond the rear of the bed should be protected by red flags during the day and red lights at night. Over width loads shall not be permitted except when necessary, and then shall travel only during the day with necessary warning flags.
12. Overhead clearance and width shall be checked before passing under low wires, cables, underpasses and bridges.
13. When vehicles are parked, engines shall be stopped and emergency brakes set.

## **28.0 MATERIAL HANDLING EQUIPMENT:**

### **A. GENERAL**

1. Only qualified personnel shall be assigned as operators. Proper regard for safety of employees and the public shall be shown by contractors.
2. All equipment shall be inspected daily and maintained in good working condition. An inspection report shall be given to the supervisor immediately upon completion.
3. All equipment shall be driven off roads or highways at night. Where any portion of any machine or equipment projects into the road it shall be marked by red lights or flares.

4. Operators shall not permit oiling or greasing, refueling or repairs until motors on the vehicles have been stopped.
5. All drive chains, sprockets, gears, V-belts, and open shafting shall be properly guarded and guards shall be kept in position when the machine is in operation.
6. Personnel sleeping or resting under equipment during rest periods shall be prohibited.
7. If there is any question as to visibility, or when working close to people on the ground, the operator should get a signal from an employee or foreman before moving.
8. Persons shall not be permitted to ride on equipment unless it is suitably equipped for such transport.
9. Personnel shall not go in between to hitch or unhitch tractor or other equipment such as trailers, dope pots and sleds until they have been stopped and the operator shall not move equipment until the employee is clear of the equipment.
10. All machine operators shall familiarize themselves with safety rules for "Road and Railroad Crossings," Section XXX 1 of this manual.
11. All blades and booms shall be lowered when equipment is not in use.
12. Workers shall not ride pipe except for balancing pipe in line up and then not in standing position.
13. Workers shall not ride boom lines, crane hooks, headache balls.
14. Pipe lines being constructed in the vicinity of high tension power lines shall be properly grounded at all times.
15. Whenever equipment is parked, the parking brake must be set. In addition, equipment parked on inclines shall have the wheels chocked.
16. Do not move construction equipment or vehicles upon any access roadway or grade unless the access roadway or grade is constructed and maintained to accommodate safely the movement of equipment and vehicles involved.

#### B. LIFTING EQUIPMENT

1. The contractor shall comply with the manufacturer's specifications and limitations applicable to the operation of any and all cranes. Where manufacturers' specifications are not available, the limitations assigned to the equipment shall be based on the determinations of a qualified engineer competent in this field and such determinations will be appropriately documented and recorded. Attachments used with cranes shall not exceed the capacity, rating or scope recommended by the manufacturer.
2. Rated load capacities, and recommended operating speeds, special hazard warnings or instructions, shall be conspicuously posted on all equipment. Instructions or warnings shall be visible to the operator while at their control station.



3. Hand signals to crane operators shall be those prescribed by the applicable ANSI standard for the type of crane in use. An illustration of the signals shall be posted at the job site.
4. The contractor shall designate a competent person who shall inspect all machinery and equipment prior to each use, and during use, to make sure it is in safe operating condition. Any deficiencies shall be repaired, or defective parts replaced, before continued use.
5. A thorough, annual inspection of the hoisting machinery shall be made by a competent person. The contractor shall maintain a record of the dates and results of inspections for each hoisting machine and piece of equipment.
6. Wire rope shall be taken out of service when any of the following conditions exist:
  - a. In running ropes, six randomly distributed broken wires in one lay or three broken wires in one strand in one lay.
  - b. Wear of one-third the original diameter of outside individual wires. Kinking, crushing, bird caging or any other damage resulting in distortion of the rope structure.
  - c. Evidence of any heat damage from any cause.
  - d. Reductions from nominal diameter of more than 1/64" for diameters up to and including 5/16", 1/32" for diameters 3/8" to and including 1/2", 3/64" for diameters 9/16" to and including 3/4", 1/16" for diameters 7/8" to 1-1/8" inclusive, 3/32" for diameters 1-1/4" to 1-1/2" inclusive.
  - e. In standing ropes, more than two broken wires in one lay in sections beyond end connections or more than one broken wire at an end connection.
  - f. Wire rope safety factors shall be in accordance with American National Standards Institute B30.5-1968 or SE J959-1966.
7. Belts, gears, shafts, pulleys, sprockets, spindles, drums, fly wheels, chains or other reciprocating, rotation, or other moving parts or equipment shall be guarded if such parts are exposed to contact by employees, or otherwise create a hazard. Guarding shall meet the requirements of the latest American National Standards Institute B15.1, Safety Code for Mechanical Power Transmission apparatus.
8. Accessible areas within the swing radius of the rear of the rotating superstructure of the crane, either permanently or temporarily mounted, shall be barricaded in such a manner as to prevent an employee from being struck or crushed by the crane.
9. All exhaust pipes shall be guarded or insulated in areas where contact by personnel is possible in the performance of normal duties.
10. Whenever internal combustion engine powered equipment exhausts in enclosed spaces, tests shall be made and recorded to see that employees are not exposed to unsafe concentrations of toxic gases or oxygen deficient atmosphere.

11. All windows in cabs shall be of safety glass, or equivalent, that introduces no visible distortion that will interfere with the safe operation of the machine.
12. Where necessary for rigging or service requirements, a ladder, or steps shall be provided to give access to a cab roof.
13. Guardrails, handholds and steps shall be provided on cranes for easy access to the car and cab, conforming to the American National Standards Institute B30.5.
14. Platforms and walkways shall have anti-skid surfaces.
15. Fuel tank filler pipe shall be located in such a position, or protected in such a manner, as to not allow spill or overflow to run onto the engine, exhaust or electrical equipment of any machine being fueled.
16. An accessible fire extinguisher of 5BC rating, or higher, shall be available at all operator stations or cabs of equipment.
17. Except where electrical distribution and transmission lines have been de-energized and visibly grounded at point of work or where insulating barriers, not a part of or an attachment to the equipment or machinery, have been erected to prevent physical contact with the lines equipment or machines shall be operated proximate to power lines only in accordance with the following:
  - a. For lines rated 50 KV or below, minimum clearance between the lines and any part of the crane or load shall be 3 meters.
  - b. For lines rated over 50 KV, minimum clearance between the lines and any part of the crane or load shall be 3 meters plus 1 centimeter for each 1 KV over 50 KV, or twice the length of the line insulator, but never less than 3 meters.
  - c. In transit with no load and boom lowered, the equipment clearance shall be a minimum of 1 meter for voltages less than 50 KV, and 3 meters for voltages over 50 KV, up to and including 345 KV, and 5 meters for voltages up to and including 750 KV.
  - d. A person shall be designated to observe clearance of the equipment and give timely warning for all operations where it is difficult for the operator to maintain the desired clearance by visual means.
  - e. If the boom or cables accidentally come into contact with an energized wire, the operator should swing the crane to get clear. If the crane cannot be cleared, the operator should stay on the crane and remain calm.
18. All employees shall be kept clear of loads about to be lifted and of suspended loads.

### C. EARTHMOVING EQUIPMENT

1. These rules apply to the following types of earthmoving equipment; scrapers, loaders, crawler or wheel tractors, bulldozers, off-highway trucks and graders.

2. Seat belts shall be provided on all equipment covered by this section.
3. Seat belts need not be provided equipment which is designed only for stand-up operation.
4. Seat belts need not be provided for equipment which does not have rollover protective structure (ROPS) or adequate canopy protection.
5. No contractor shall move or cause to be moved construction equipment or vehicles upon any access roadway or grade unless the access roadway or grade is constructed and maintained to accommodate safely the movement of the equipment and vehicle involved.
6. Every emergency access ramp and berm used by a contractor shall be constructed to restrain and control runaway vehicles.
7. All earthmoving equipment mentioned in this section shall have a service braking system capable of stopping and holding the equipment fully loaded.
8. All bidirectional machines, such as rollers, compactors, front-end loaders, bulldozers and similar equipment, shall be equipped with a horn, distinguishable from the surrounding noise level, which shall be operated as needed when the machine is moving in either direction. The horn shall be maintained in an operative condition.
9. No contractor shall permit earthmoving or compacting equipment which has an obstructed view to the rear to be used in reverse gear unless the equipment has in operation a reverse signal alarm distinguishable from the surrounding noise level or an employee signals that it is safe to do so.
10. Scissor points on all front-end loaders, which constitute a hazard to the operator during normal operation, shall be guarded.

#### D. PILE DRIVING EQUIPMENT

1. Overhead protection, which will not obscure the vision of the operator shall be provided. Protection shall be the equivalent of five centimeter planking or other solid material of equivalent strength.
2. Stop blocks shall be provided for the leads to prevent the hammer from being raised against the head block.
3. A blocking device, capable of safely supporting the weight of the hammer, shall be provided for placement in the leads under the hammer at all times while employees are working under the hammer.
4. Guards shall be provided across the tip of the head block to prevent the cable from jumping out of the sheaves.
5. When the leads must be inclined in the driving of batter piles, provisions shall be made to stabilize the leads.

6. Fixed leads shall be provided with ladder, and adequate rings, or similar attachment points, so that loft workers may engage their safety belt lanyard to the leads. If the leads are provided with loft platform(s), such platform(s) shall be protected by standard guardrails.
7. Steam hose leading to a steam hammer or jet pipe shall be securely attached to the hammer with an adequate length of at least 1/2 centimeter diameter chain or cable to prevent whipping in the event the joint at the hammer is broken. Air hammer hoses shall be provided with the same protection as required for steam lines.
8. Safety chains, or equivalent means, shall be provided for each hose connection to prevent the line from thrashing.
9. Steam line controls shall consist of two shutoff valves, one of which shall be a quick acting lever type within easy reach of the hammer operator.
10. Guys, outriggers, thrustouts or counterbalances shall be provided as necessary to maintain stability of pile driver rigs.
11. Engineers and winchers shall accept signals only from the designated signalers.
12. All personnel shall be kept clear when piling is being hoisted into the leads.

#### E. DITCHING MACHINES

1. All machine guards shall be properly maintained and kept in position when the ditching machine is in operation.
2. The machine operator shall be held responsible for maintaining the machine and equipment in a safe and satisfactory operating condition.
3. Cleaning rocks, roots, or dirt from buckets on digging wheel or conveyor shall not be done while machine is in motion.
4. Cables and fastenings shall be checked daily on digging wheel, and conveyors and brakes shall be checked before operating machine on inclines.
5. Operator shall demand that all employees or public stand in the clear of the conveyor as well as the digging wheel while machine is in operation.
6. Operator shall make sure that all employees are clear of the machine, and that all persons employed in the operation have been located or accounted for before operator moves the machine or engages the clutch of the digging wheel.
7. Employees shall stand clear of skids or timbers placed under the ditcher tracks.

In addition to the requirement specified in the preceding paragraphs, all of the requirements under Material Handling Equipment in this manual shall be followed and observed.

#### F. BULLDOZERS

1. All steps, tracks or any surface used to mount the rig shall be clean, dry, free of grease, oil, mud or dirt.
2. All controls are properly set for start-up and all guards and safety devices are in place and working.
3. The bulldozer operator shall make certain that all employees are off and completely clear of the bulldozer before any operations are initiated.
4. Bulldozers shall be equipped with headache racks or protective cover constructed of material sufficiently strong to protect operator when they are used in clearing operations.
5. The bulldozer shall not be operated on right-of-way unless the brush crew is in the clear.
6. Operators shall make certain that helpers are in the clear when stumps are pulled by winch and cable.
7. Operator shall never attempt to make any repairs or adjustments or grease machine without first disengaging clutch, and shutting machine down.
8. Substantial cribbing should be provided if necessary to work on or under the raised blade.

In addition to the requirements specified in the preceding paragraphs, all of the requirements under Material Handling in this manual shall be followed and observed.

#### G. SIDEBOOMS AND TOW TRACTORS

1. Before operating a sideboom or tow tractor, operator shall make sure everyone is in the clear. Workers shall not stand beneath tractor boom when lifting or lowering.
2. No tractor or sideboom shall be operated until all controls have been inspected, tested and are in good working order.
3. Operators are responsible for winch brakes, cable and pipe on side booms. Faulty winch brakes must be repaired before using tractor.
4. Personnel shall not stand directly in front of cable hitches, tractors and pipe during "bending" operations or moving of pipe.
5. Personnel shall not pass under or work under a suspended load inside the angle of winch line, or near a cable, chain or rope.
6. Pipe shall never be picked up or lowered while any personnel are between the tractor and the pipe, and pipe shall never be carried over heads of personnel.
7. No one should give signals, directions or other instructions to an equipment operator unless they have been trained, authorized and directed to do so.

8. No operator shall leave their operating position while a load is hanging or held up by the sideboom without blocking under the load.
9. Operator shall not allow anyone to ride on the machine unless specific preparation is made for such transport.
10. All sideboom hooks shall be equipped with a safety catch or lock to prevent cable slipping out.
12. A chain shall be attached to each sideboom and belt or line chained to boom when tractor is not carrying a load and is moving along the right-of-way.
13. A tractor or sideboom shall not be run across a ditch until it has been ascertained that no injury can result if ground does cave in.
14. When dozing sides of ditch or backfilling, no workers shall be in the ditch.

In addition to the requirements specified in the preceding paragraphs, all of the requirements under Material Handling in this manual shall be followed and observed.

#### H. FUELING OF EQUIPMENT

1. Tank trucks used to transport split loads of gasoline, diesel and other fuels shall be the type provided with double bulkheads and drainage between compartments to prevent contamination from leaks. A separate pump shall be used for gasoline only, and there shall be no connecting lines between compartments.
2. The dome openings and draw-off faucets shall be painted identifying colors such as red for gasoline; green for kerosene; and black for diesel fuel. The dome openings for the tank trucks compartments shall have the names of the products stenciled around them.
3. An outer shield shall be placed over the muffler on all fuel trucks. The tail pipe shall be extended to a safe point clear of the unloading connections and the pump.
4. Each fuel truck shall be provided with at least one approved fire extinguisher, such as a seven kilogram dry chemical type.
5. Motors on equipment shall be stopped and burners on dope pots extinguished before refueling.
6. Smoking within 30 meters shall be prohibited while equipment is being fueled and in the case of gasoline, there shall be no open fires, welding or burning in the nearby area.
7. Care shall be taken not to overfill any equipment with fuel. If fuel is spilled the engine or burner shall not be started.
8. In fueling equipment, the metal fill nozzle shall be kept in contact with the lip of the tank opening to eliminate any static accumulation.
9. Gasoline shall never be handled in open containers, and safety cans shall be used when handling small quantities.

10. The washing of equipment parts, hands or any object with gasoline shall be prohibited, and fuel truck drivers shall not dispense it for that purpose. A standard solvent, kerosene or diesel fuel shall be used for washing equipment parts. Hands can be cleaned with water less, grease removing creams and/or soap and water.
11. Fuel trucks shall be equipped with reflectors or approved dry cell battery type warning lights for emergency highway use.
12. Stationary storage fuel tanks shall be vented and entirely clear of buildings or equipment at the warehouse. If the tanks are not buried, they shall be grounded and properly vented.
13. The fill nozzle opening on all equipment shall have a fastened cap in place except when the tank is being filled.
14. Fueling equipment shall be equipped with grounding wire that will be attached to the equipment it is serving to eliminate static electrical charges.

#### I. MAINTENANCE, REPAIRS, SERVICING

1. No service, repairs or maintenance shall be done on any machine or equipment until it has been moved to a place where the machine will not be exposed to vehicle or equipment traffic and out of the work area unless and until proper barricades and guards have been set up to provide a safe working area.
2. No work shall be done on any machines or equipment for any purpose until and unless the equipment has been shut down and locked out, brakes set, and all blades, buckets, etc., have been lowered completely to the ground or properly blocked.
3. Machine parts shall not be washed in gasoline; either kerosene, diesel oil, or a safety solvent shall be used.
4. Suspended motors or machinery, etc., beneath which mechanics must work shall be blocked or cribbed.
5. Hoisting equipment shall be carefully examined before using on heavy loads.
6. All guards should be replaced after repairs have been completed.
7. New parts for installation and old parts removed from a machine must be placed in the clear.
8. Tools, such as hammers, chisels and wrenches, shall be kept in safe workable condition and each employee shall be responsible for the condition of that equipment and tools which he uses.
9. Employees shall wear goggles when using buffers, emery wheels and grinders, and while chipping and cutting.

10. Do not strike two hardened metal surfaces together, such as a ball peen hammer against a shaft. Use a wooden block between high carbon surfaces, or a soft-headed hammer.
11. All electrical equipment shall be adequately grounded. Extension cords and outlets shall be kept in good repair.
12. Mechanics' truck shall have at least one 15-pound dry chemical fire extinguisher.
13. No welding, brazing, or cutting should be done on any tank or vessel which has contained flammable liquids unless it has been gas freed and/or thoroughly washed and completely filled with water.
14. Drivers of fuel trucks shall be required to keep the equipment in good condition and such drivers shall follow all applicable rules under "Operation of Automotive Equipment."

## **29.0 WORKING OVER OR NEAR WATER:**

### **A. PERSONNEL SAFETY**

1. Employees working over or near water, where the danger of drowning exists, shall be provided with life jackets or buoyant work vests.
2. Prior to and after each use, the buoyant work vests or life preservers shall be inspected for defects which would alter their strength or buoyancy. Defective units shall not be used.
3. Ring buoys with at least 25 meters of line shall be provided and readily available for emergency rescue operations. Distance between ring buoys shall not exceed 60 meters.
4. At least one lifesaving skiff shall be immediately available at locations where employees are working over or adjacent to water.

### **B. MATERIAL HANDLING OPERATIONS**

1. Ramps for access of vehicles to or between barges shall be of adequate strength, provided with side boards, well maintained and properly secured.
2. Unless personnel can step safely to or from the wharf, float, barge or river towboat, either a ramp, or a safe walkway, shall be provided.
3. When the upper end of the means of access rests on or is flush with the top of the bulwark, substantial steps, properly secured and equipped with at least one substantial handrail approximately 80 centimeters in height, shall be provided between the top of the bulwark and the deck.
4. Obstructions shall not be laid on or across the gangway.



5. Unless the structure makes it impossible, the means of access shall be so located that the load will not pass over employees.
6. Only experienced and qualified personnel shall be allowed to handle boats of any type.
7. Every launch or motor boat shall be equipped with two oars and shall never leave dock without them.
8. Each boat, barge and dredge shall be equipped with sufficient fire extinguishers to control fires, and with other appropriate marine safety equipment.
9. A spare motor of sufficient power shall be provided for each boat for emergency use.
10. Boats and work barges shall never be overloaded either with personnel and/or equipment and/or supplies. The load shall be properly distributed to prevent capsizing.
11. Fuel supply shall not be kept on work barges or dredges because of the fire hazard.
12. When a dragline is used on a barge for digging, it shall be firmly secured to the barge.

### C. WORKING SURFACES OR BARGES

1. Only authorized personnel shall be allowed on barges and dredges.
2. Personnel shall not be permitted to walk along the sides of covered lighters or barges with coamings more than 1 1/2 meters high, unless there is a 1 meter clear walkway, or grab rail, or taut handline is provided.
3. Decks and other working surfaces shall be maintained in a safe condition.
4. Personnel shall not be permitted to pass fore and aft, over, or around deckloads, unless there is a safe passage.
5. Personnel shall not be permitted to walk over deckloads from rail to coaming unless there is a safe passage. If it is necessary to stand at the outboard or inboard edge of the deckload where less than 60 centimeters of bulwark, rail coaming, or other protection exists, all employees shall be provided with a suitable means of protection against falling from the deckload.
6. The contractor shall ensure that there is in the vicinity of each barge in use at least one 7 1/2 meter lifering with not less than 25 meters of line attached, and at least one portable or permanent ladder which will reach the top of the apron to the surface of the water. If the above equipment is not available at the pier, the employer shall furnish it during the time that he is working the barge.
7. Employees walking or working on the unguarded decks of barges shall be protected with work vests or buoyant vests.

## 30.0 CONSTRUCTION GUIDELINES

### A. CLEARING AND GRADING

1. Employees engaged in site clearing shall be protected from hazards of irritant and toxic plants and suitably instructed in the first aid treatment available.
2. All equipment used on site or right-of-way clearing operations shall be equipped with rollover guards. In addition, rider operated equipment shall be equipped with an overhead and rear canopy guard meeting the following requirements.
  - a. The overhead covering on this canopy structure shall be of not less than 1/4 centimeter steel plate or 1/2 centimeter woven wire mesh with openings no greater than 1 inch, or equivalent.
  - b. The opening in the rear of the canopy structure shall be covered with not less than 1/2 centimeter woven wire mesh with openings no greater than 2 1/2 centimeters.
3. Area to be graded and cleared shall be checked for underground cables, lines, etc.
4. Timber clearing and felling shall be done under the direction of an experienced and competent person familiar with safe practices necessary in these operations.
5. The contractor shall provide and assure that each employee who operates a chain saw wears leg protection constructed with cut-resistant material, such as ballistic nylon. The leg protection shall cover the full length of the thigh to the top of the boot on each leg to protect against contact with a moving chain saw. Exception: This requirement does not apply when an employee is working as a climber if the employer demonstrates that a greater hazard is posed by wearing leg protection in the particular situation, or when an employee is working from a vehicular mounted elevating and rotating work platform.
6. Employees cutting underbrush shall be well ahead of the tree felling operations.
7. Axes shall be carried at the side with the hand grasping the axe handle close to the axe head.
8. Power saw operators shall stay back of the saw and not reach in front of it to untangle vines, etc., while the saw is in motion.
9. All cutting tools shall be sharpened regularly and inspected daily for defects. Double bitted axes shall not be used where there is much heavy underbrush and vines. Employees shall be spaced well apart so there will be no danger of one person hitting another.
10. Care shall be taken to keep legs and feet out of the line of swing of the axe in case it glances off timber.
11. Fellers or buckers shall not be placed on hillsides immediately below each other where there is danger from skidding or rolling timber.

12. Fellers shall give timely warning to buckers and other persons in the vicinity where trees are being felled so they are not only out of the reach of the tree, but are also out of danger of possible sidewinders, snags, or other trees which may be knocked by the tree being felled.
13. The following precautions shall be taken at all times:
  - a. Watch out for loose limbs and bark on all snags and trees; particularly if previously felled trees have struck them.
  - b. Watch out for kickbacks of saplings and kickbacks from butts of felled trees.
  - c. All dangerous snags shall be felled.
  - d. Put large undercuts on heavy leaners.
  - e. Do not trust "holding wood" on the trees with heavy center rot.
  - f. Prior to felling any tree, brush or other potential obstacles which might interfere with cutting the tree or the retreat path shall be removed.
  - g. Employees in charge of cutting crews shall be careful when approaching a set of fellers.
14. Fellers and buckers shall not work if the wind is strong enough to prevent the falling of trees in the direction desired.
15. All work shall terminate and each employee shall move to a place of safety when environmental conditions, such as but not limited to, electrical storms, strong winds which may affect the fall of a tree, heavy rain or snow, extreme cold, dense fog, fires, mudslides, and darkness, create a hazard for the employee in the performance of the job.
16. Buckers shall not stand on the lower side of the log unless the log has been chocked.
17. Buckers shall not work alone.
18. At all power line crossings, the "Danger-Power Line" signs shall be installed immediately after clearing has been completed. These signs shall be placed approximately one hundred feet on each side of the power line and in a position where the sign will be seen by all vehicles traveling the right-of-way.
19. Slash and small timber shall be piled and burned in a clearing of sufficient size to prevent the spread of fire.
20. Where there may be danger of fire spreading to adjacent standing timber or ripe grain fields or grass lands, a safety strip of sufficient width shall be plowed.
21. Fire fighting equipment shall be on hand whenever brush or other materials are to be burned.
22. Long handle torches shall be used in firing piles.
23. A check shall be made to see that all fires are out before leaving the area.
24. Each chain saw shall be equipped with a chain brake and must be operated and adjusted in accordance with the manufacturer's instructions.

## B. EXCAVATION AND SHORING

### 1. Specific Excavation Requirements

- a. Prior to opening an excavation, effort shall be made to determine whether underground installation ( i.e., sewer, telephone, water, pipelines, etc.), will be encountered, and if so, where such underground installations are located. When the excavation approaches the estimated locations of such an installation, the exact location shall be determined and when it is uncovered, proper supports shall be provided for the existing installation. Utility companies shall be contacted and advised of proposed work prior to the start of actual excavation.
- b. Trees, boulders and other surface encumbrances, located so as to create a hazard to employees involved in excavation work or in the vicinity thereof at any time during operations, shall be removed or made safe before excavating is begun.
- c. The walls and faces of all excavations in which employees are exposed to danger from moving ground shall be guarded by a shoring system, sloping of the ground, or some other equivalent means, or by a combination of such means.
- d. Daily inspections of excavations, the adjacent areas, and protective systems shall be made by a competent person for evidence of a situation that could result in possible cave-ins, indications of failure of protective systems, hazardous atmospheres, or other hazardous conditions. An inspection shall be conducted by the competent person prior to the start of work and as needed throughout the shift. Inspections shall also be made after every rainstorm or other hazard increasing occurrence. These inspections are only required when employee exposure can be reasonably anticipated.
- e. Where the competent person finds evidence of a situation that could result in a possible cave-in, indications of failure of protective systems, hazardous atmospheres, or other hazardous conditions, exposed employees shall be removed from the hazardous area until the necessary precautions have been taken to ensure their safety.
- f. The determination of the angle of repose and design of the supporting system shall be based on careful evaluation of pertinent factors such as: depth of cut; possible variation in water content of the material while the excavation is open; anticipated changes in materials from exposure to air, sun, water or freezing; loading imposed by structures, equipments, overlying material or stored material; and vibration from equipment, blasting, traffic or other sources.
- g. Supporting systems ( i.e., piling cribbing, shoring, etc.), shall be designed by a qualified person and meet accepted engineering requirements. When tie rods are

used to restrain the top of sheeting or other retaining systems, the rods shall be securely anchored well back of the angle of repose. When tight sheeting or sheet piling is used, full loading due to ground water table shall be assumed, unless prevented by weep holes or drains or other means. Additional stringers, ties and bracing shall be provided to allow for any necessary temporary removal of individual supports.

- h. All slopes shall be excavated to at least the angle of repose except for areas where solid rock allows for line drilling or pre-splitting.
- i. The angle of repose shall be flattened when an excavation has water conditions, silty materials, loose boulders and areas where erosion, deep frost action and slide planes appear.
- j. In excavations which are being hand excavated or where employees may be required to enter, excavated or other material shall be effectively stored and retained at least 1/2 meter or more from the edge of the excavation.
- k. If it is necessary to place or operate equipment, or other heavy objects on a level above and near an excavation, the side of the excavation shall be sheet-piled, shored and braced as necessary to resist the extra pressure due to such superimposed loads.
- l. Adequate barrier physical protection shall be provided, and where personnel or equipment are required or permitted to cross over excavations, walkways or bridges with standard guardrails shall be provided.
- m. Workers directing clam or bucket operations shall stand clear of edge of ditch because of danger of cave-ins.

## 2. Specific Trenching and Shoring Requirements

- a. Banks more than 1 1/2 meters high shall be shored, laid back to stable slope or some other equivalent means of protection shall be provided where employees may be exposed to moving ground or cave-ins. Trenches less than 1 1/2 meters in depth shall also be effectively protected when examination of the ground indicates hazardous ground movement may be expected.
- b. Sides of trenches in unstable or soft material, 1 1/2 meters or more in depth, shall be shored, sheeted, braced, sloped, or other wise supported by means of sufficient strength to protect the employees working within them.
- c. Sides of trenches in hard or compact soil, including embankments, shall be shored or otherwise supported when the trench is more than 1 1/2 meters in depth and 8 feet or more in length. In lieu of shoring, the sides of the trench above the 1 1/2

meter level may be sloped to preclude collapse, but shall not be steeper than a 30 centimeter rise to each 15 centimeter horizontal.

- d. Materials used for sheeting and sheet piling, bracing, shoring and underpinning, shall be in good serviceable condition, and timbers used shall be sound and free from large or loose knots, and shall be designed and installed so as to be effective to the bottom of the excavation.
- e. Additional precautions by way of shoring and bracing shall be taken to prevent slides or cave-ins when excavations or trenches are made in locations adjacent to backfilled excavations, or where excavations are subjected to vibrations from railroad or highway traffic, the operation of machinery or any other source.
- f. When employees are required to be in trenches 1 meter deep or more, an adequate means of exit, such as ladders or steps, shall be provided and located so as to require no more than 8 meters of lateral travel.
- g. Bracing or shoring of trenches shall be carried along with the excavation.
- h. Cross braces or trench jacks shall be placed in true horizontal position, be spaced vertically and be secured to prevent sliding, falling or kickouts.
- i. Portable trench boxes or slinging trench shields may be used for the protection of personnel in lieu of shoring system or sloping. Where such trench boxes or shields are used, they shall be designed, constructed and maintained in a manner which will provide a protection equal to or greater than the sheeting or shoring required for the trench.
- j. Backfilling and removal of trench supports shall progress together from the bottom of the trench. Jacks or braces shall be released slowly and, in unstable soil, ropes shall be used to pull out the jacks or braces from above after employees have cleared the trench.

#### C. UNLOADING AND STRINGING PIPE

1. Care shall be taken to keep personnel in the clear when cutting steel bands securing pipe to the railroad car.
2. Extreme care shall be exercised in spotting the lifting equipment at a railroad siding when unloading pipe so that there is adequate clearance of overhead wires, particularly of high voltage electric power lines.
3. The tail rope shall be of sufficient length to enable the man hooking the pipe to stand in the clear while guiding the pipe.
4. Where ramp skids are used, they shall be of ample size, sound hardwood, securely fastened, and shall have a gradual incline. Long ramp skids shall be supported. Pipe

shall extend three or four feet over each end, and employees shall work at the ends of the pipe to avoid being caught between two sections or joints.

5. Each tier of pipe shall be scotched when spacers are used in racking pipe.
6. A red flag shall be placed at the rear end of trucks hauling pipe.
7. Fence gaps shall be kept closed and trucks shall stay on the right-of-way.
8. Suitable signs or flags shall be placed on highways at points where trucks are turning off to string pipe.

#### D. BENDING AND CUTTING

1. All personnel shall stand in the clear when actual bending operations are in progress.
2. The bending machine operator shall be held responsible for making daily inspection of all cables, cable clamps, brakes, etc., and any defects discovered shall be corrected immediately and reported to the supervisor.
3. Swamper or helper shall not ride pipe being moved to and from the bending machine.
4. Pipe shall be adequately supported in pipe cutting operations; where short sections are cut off, employees shall be in the clear of falling pipe.
5. Rules on tractor operations and power machinery shall be applied to all power equipment used in pipe bending.

In addition to the requirements specified in the preceding paragraphs, all of the requirements under Material Handling Equipment (Section XXVIII) shall be followed and they shall be observed.

#### E. PIPE LAYING

1. Employees guiding pipe shall handle it from the side and not place hands over the ends.
2. Care shall be taken to see that pipe is securely set on skids. Pipe shall be scotched at intervals and at all loose ends to prevent moving.
3. All skids shall be of a size adequate for the load.
4. All skid material shall be carefully inspected by workers on skid trucks, and any defective and broken skids shall be rejected and destroyed.
5. Employees handling skids shall wear leather or leather-pad gloves.
6. Workers shall move from under the boom after the caliper or cable has been secured.
7. No more than 3 or 4 skids shall be placed together. If more skids are needed, a four square crib shall be built to support the pipe.
8. Skids being transported shall be securely boomed to the truck bed.

9. Care shall be taken in the use of hammers to prevent injuries to other employees.

#### F. CLEANING, COATING AND WRAPPING

1. Employees handling or working around hot dope or primer shall wear top shoes or boots with trouser legs on the outside and have full length sleeves extending over the top of gloves.
2. Employees engaged in cleaning, priming, or doping operations, where fumes, rust, dust, and other particles are excessive, shall wear safety goggles and respirators.
3. Where fumes from hot dope cause irritation to the face and neck a protective cream shall be provided and applied before work is started.
4. Buckets shall never be filled over two-thirds capacity to prevent hot dope splashing over the edge of the bucket. Defective buckets shall not be used.
5. Employees engaged in cutting the dope and charging dope kettles shall wear suitable goggles.
6. Burners on dope kettles shall be cleaned and inspected at regular intervals to keep them in good condition, and kettle firemen shall be cautioned about "flashbacks."
7. Dope kettles shall be equipped with down spouts, and cut off valves shall be of the quick-closing type.
8. When small hot dope kettles are being moved, lids shall be closed and the fire shall be cut down and employees warned to stay in the clear of splashing.
9. Always remove caps or plugs from primer or cold dope carefully as pressure often builds up in the drum.
10. Employees shall not place body over the outrigger pole in balancing the cleaning or wrapping machine, due to the possibility of a "kick." The pole shall be grasped in the hands.

In addition to the requirements specified in the preceding paragraphs, all of the requirements under Head Protection, Hearing Protection, Eye and Face Protection, Respiratory Protection, Fire Protection, Fire Prevention, and Flammable and Combustible Liquids shall be followed and they shall be observed.

#### G. LOWER-IN AND TIE-IN

1. Lowering shall be directed by the foreman in charge. Signals and other orders to the tractor operators must come from the foreman only.



2. No employee shall be in the ditch, or on the pipe, or between the pipe and ditch along the entire length of the continuous section of the line while pipe is in process of being lowered.
3. All belt slings and wire rope connection shall be checked before each lowering operation, and the belt slings and boom lines should not be hooked to the boom while the tractor is moving.
4. Bell holes shall be of adequate size and properly sloped to enable the welders to work without danger of cave-ins.
5. Adequate preparations shall be taken to prevent sideboom tractor from falling into ditch while lowering pipe.

In addition to the requirements specified in the preceding paragraphs, all of the requirements under Signaling, Material Handling Equipment, Specific Excavation Requirements, and Specific Trenching Requirements shall be followed and they shall be observed.

#### H. BACKFILL AND CLEAN UP

1. The machine operator shall be careful to keep his machine on the right-of-way and not damage crops or other property over the designated right-of-way lines.
2. The clean up crew shall be careful to see that all dynamite wrappers, chunks of dope, and miscellaneous metal and glass are removed so that animals will not be injured by eating or walking on same.

#### I. ROADWAY AND RAILROAD CROSSINGS

1. Be sure any necessary permits have been obtained before cutting or boring any railroad or road. Any host country regulations relative to cutting, backfilling and compaction shall also be observed.
2. Check with proper authorities to determine if any lines are located under or near railroad or highway to be bored or cut.
3. Barricades, warning signs, etc., shall be erected on each side of the road before excavation is started.
4. On heavily traveled primary roads, adequate warning signs shall be placed at intervals of 60, 120, and 180 meters from the center line of the pipe line ditch. Flashers shall be placed at signs at night for illumination.
5. On secondary roads, adequate warning signs shall be placed 60 meters from the center line of the pipe line ditch, with flashers at each sign for illumination at night.

6. Hoe, dragline and ditching machine operators shall instruct oilers to inspect ditch for any sign of uncharted lines, drain tiles, etc.
7. Flaggers shall be stationed 60 meters on each side of the center line of the ditch when equipment is being moved across a highway.
8. A watchman shall make the rounds at night to see that "flashers" are being used and that they are in proper location and operating satisfactorily.
9. Temporary bridges with guardrails on each side shall be constructed over excavations crossing secondary highways. Materials used shall be satisfactory to handle load to cross bridge.
10. No cleated equipment shall be driven across hard surfaced highways without protecting the surface of the highway.
11. Warning signs and flashers shall not be removed until road crossings are properly tamped, leveled, shoulders repaired and drainage ditches cleared.
12. One rail shall always be covered before crossing mainline railroads with tractors, sleds or other equipment which might create a short in the signal equipment.
13. Equipment shall not cross railroad tracks until flaggers have indicated that it is safe to do so.
14. Care shall be taken in crossing railroad tracks that all mud, broken skids, planks, etc., are clear of the rail before leaving the crossing.
15. Supervisors shall make an inspection of the rails and/or ties immediately after crossing equipment to be certain the rails and/or ties have not been damaged.
16. If damage is discovered to the rails, ties or any part of the railroad, two flaggers shall be stationed, one on each side at least 100 meters in each direction, of the damaged point, to stop all trains. Notify the nearest railroad agent immediately so that the damage can be repaired.
17. Where there is doubt as to soil conditions, especially when boring under highways and railroads, proper shoring shall be provided or the ditch sloped well back because of the danger of vibration from moving traffic.
18. Material from ditch shall be recast a safe distance from edge so the ditch wall is not overloaded and in danger of caving in.
19. Extreme caution shall be used to protect against ditch caving when bottom soil condition is wet or rain has occurred overnight.
20. Moving parts of the road boring equipment shall be well guarded and protection provided to keep employees clear of snatch blocks and cables under strain.

In addition to the requirements specified in the preceding paragraphs, all of the requirements under Accident Prevention, Signs and Barricades, Material Handling

Equipment, Specific Excavation Requirements, and Specific Trenching Requirements shall be followed and they shall be observed.

J. UNLOADING AND SETTING MAINLINE VALVES

1. Extreme caution must be followed in unloading main line valves due to their weight.
2. A competent person must determine soil conditions in and around the ditch for the purpose of evaluating soil compactness or cave-in potential due to weight.
3. Keep unauthorized personnel away from the lift area during the lifting.
4. Hand lines should be used for the condition of the sling and proper sizing.
5. Under no circumstances shall a valve be winched from a low boy or trailer.
6. Properly designed cribbing must be used for storage of valves.

**31.0 SPILL RESPONSE:**

- A. Employees should be informed of the hazards of a release or spill of any hazardous substance present at the construction sites.
- B. The contractor should designate the type of equipment, personal protective equipment that needs to be used in the event of a spill or release of a hazardous substance.
- C. Qualified employees should be instructed in the procedures to be used to control and/or clean up the hazardous spill or release.

**APPENDIX D**  
**CONTINGENCY PLAN**

*BOLIVIA-BRAZIL GAS PIPELINE PROJECT*

**APPENDIX D  
CONTINGENCY PLAN**

**TABLE OF CONTENTS**

1.0	INTRODUCTION .....	D- 1
1.1	GENERAL .....	D- 1
1.2	CONTINGENCY PLAN DISTRIBUTION .....	D- 2
2.0	CONTINGENCY MANAGEMENT STRATEGIES .....	D- 3
2.1	PREVENTIVE MEASURES .....	D- 3
2.2	REQUIRED EMERGENCY EQUIPMENT .....	D- 3
2.3	PERSONNEL TRAINING .....	D- 5
2.4	MEDIA RESPONSE .....	D- 6
3.0	EMERGENCY RESPONSIBILITIES .....	D- 7
4.0	GENERAL EMERGENCY PROCEDURES .....	D- 9
4.1	EMERGENCY REPORTING .....	D- 9
4.2	EMERGENCY TEAM NOTIFICATION .....	D- 11
4.3	EVACUATION PROCEDURES .....	D- 13
4.4	EMERGENCY SITE SECURITY .....	D- 14
5.0	HAZARDOUS SUBSTANCE RELEASE RESPONSE PROCEDURES .....	D- 14
6.0	EXPLOSION/FIRE PROCEDURES .....	D- 16
6.1	STATION .....	D- 16
6.2	PIPELINE .....	D- 17
7.0	GAS RELEASE/PIPELINE LEAK .....	D- 19
7.1	STATION .....	D- 19
7.2	PIPELINE .....	D- 19
8.0	NATURAL DISASTERS (STATION AND PIPELINE) .....	D- 20
9.0	OPERATIONS WITH LOSS OF COMMUNICATIONS (STATION AND PIPELINE) .....	D- 21
10.0	EMERGENCY REPAIRS/SERVICE RESTORATION .....	D- 22
10.1	PIPELINE REPAIR PROCEDURES .....	D- 22
10.2	RESTORATION OF PIPELINE SERVICE .....	D- 23

## APPENDIX D CONTINGENCY PLAN

### 1.0 INTRODUCTION

#### 1.1 GENERAL

This Appendix presents a preliminary contingency plan for the Bolivia to Brazil gas pipeline project. This plan is intended to provide general procedures to be implemented along the pipeline right-of-way and at each of the proposed four compressor station facilities in the event of an emergency situation caused by natural, accidental, or subversive events during the construction and operation phases of the project.

The procedures presented in the plan are to be followed by project personnel in the event of an emergency situation to facilitate a quick and effective response to protect human lives and environmental resources present at or near any affected project facilities. These procedures do not replace responsible action based on experience, but they do establish guidelines which serve to call attention to the many people - employees, customers, law enforcement agencies, bystanders - involved in an emergency located close to or within the pipeline right-of-way or any of its related facility facilities.

The purpose of the contingency plan is to outline the procedures to be carried out by project personnel in case of an emergency caused by unexpected events (earthquake, flood, explosion, or other events related to human errors). The plan has been prepared to minimize hazards to human health and the environment from fire and any unplanned sudden or non-sudden release of hazardous materials to the air, soil, groundwater or surface water.

It should be recognized that during construction, the project will require the use and storage of several types of hazardous substances at or near the sites of the proposed facilities. During the operational phase of the project, the pipeline will transport natural gas on a permanent basis

during the entire life of the project. A release of any of these substances could result in an emergency situation.

Should a hazardous substance release occur, the Emergency Coordinator shall deploy such manpower, equipment, and any other resources as may be required, to minimize the risk to human health or the environment. Any released material shall be cleaned up and disposed of in an environmentally acceptable manner.

## 1.2 CONTINGENCY PLAN DISTRIBUTION

Manuals of this contingency plan will be distributed as follows:

1. Superintendents, Foremen
2. Specialty Technician
3. Control Rooms
4. Administrative office of each location
5. All unassigned company field vehicles
6. Division staff, except administrative personnel
7. Pipeline Services
8. Division and district specified emergency response

## **2.0 CONTINGENCY MANAGEMENT STRATEGIES**

### **2.1 PREVENTIVE MEASURES**

Preventive measures required to handle the project hazardous materials include storage locations for fire prevention, secondary containment for outside aboveground tanks and container labeling, and automatic shutdown safety valves for the gas pipeline. The areas for accumulation of hazardous waste shall be maintained in a manner to minimize health hazards and environmental pollution. These areas shall remain clear of fire and explosion hazards. The access to these areas shall remain free from obstruction to allow admission of emergency response teams. When the drums are not being used, they shall be kept closed. An Environmental Specialist shall perform area inspections and check all Accumulation Areas. These inspections will determine if the regulations outlined previously are being followed. If a discrepancy is noticed, the appropriate foreman shall be notified to have the problem corrected immediately.

### **2.2 REQUIRED EMERGENCY EQUIPMENT**

The following is a list of the emergency equipment that should be available at each compressor station.

#### **A. Fire Protection:**

- Fire Equipment Buildings
- Portable fire extinguishers
- Carbon Dioxide System
- Halon Extinguisher System
- Wall-mounted fire extinguishers



B. Spill Containment Equipment: Safe Step and Oil Sorb or equivalent. Each of these adsorbents is capable of containing and absorbing a spill to promote an expedient cleanup of the area. These can be used to contain a spill until an absorbent can be applied.

C. Neutralizing Agents:

1. Soda Ash in solid and liquid form is available for neutralizing acid spills.
2. Nalco 295 and Sulfamic Acid shall be available for neutralizing caustic spills of less than 100 gallons.

D. Protective Clothing:

1. Rubber Suits: Complete rubber suits including head, hand and foot protection. The suits are suitable for use with self-contained breathing apparatus and provide protection from corrosives.
2. Rubber Gloves: Rubber gloves will be kept in the warehouse and in work areas throughout the facility.
3. Rubber Boots: Rubber boots will be kept in the warehouse and in work areas throughout the facility.
4. Respirators: Personal respirators will be issued to all certified personnel whose job description indicates a need. The respirators use interchangeable cartridges to protect from different hazards such as organic vapors, acid fumes, particulates, etc. The different cartridges for the respirators will be available in the warehouse.
5. Face Shields: Face shields that attach to hard hats will be available to protect the face from chemical splashes and other hazards.

6. Chemical Goggles: Chemical goggles that provide protection for the eyes will be kept in the warehouse.

E. Communication Systems:

1. Phone System: If feasible, phones will be located at each of the compressor stations and other facilities.
2. Radio System: Two-way radios will be carried by facility personnel.

F. Alarm Systems:

1. Facility Evacuation Alarm: An alarm system will be installed in each compressor station to alert station personnel of the occurrence of an emergency.
2. Alarm Siren: The alarm siren, used to alert emergency response teams, is activated in the Control Room by an operator and sounds throughout the facility.

- G. First Aid Supplies: Each compressor station will be equipped with first aid supplies, stretchers, and eye wash stations. In addition, at least one staff member trained in first aid techniques.

### 2.3 PERSONNEL TRAINING

All Maintenance, Operation, Engineering and Warehouse personnel involved with the handling or management of hazardous substances shall be instructed on the applicable hazardous substance regulations and appropriate chemical safety procedures. New employees shall be instructed on the applicable regulations during the first 6 month period after their employment date. Also, the Emergency Coordinators and the Warehouse managers shall receive additional training concerning the specific aspects of their duties. This training will be coordinated and conducted by the Facility Representative and Safety/Security Coordinator. Additionally, members of the

Emergency Response Team are trained in emergency response tactics using the Incident Command System.

## 2.4 MEDIA RESPONSE

Only personnel who have been trained on how to deal with the media in an emergency situation will field press inquiries. Company personnel should direct any media inquiries to trained individuals and should tell any press at the scene that someone with responsibility for communicating with them will arrive soon. If no trained media personnel are available, refer all inquiries to appropriate Public Affairs personnel.

### What the Trained Media Spokesperson Should Tell the Media

If you are a trained media spokesperson, use the following guidelines to communicate with the media at an emergency situation. Refer to separate list below of do's and dont's.

1. Confirm that there is a problem and state its nature. Do not speculate about its cause.
2. State the number of persons hurt and/or unaccounted for, if this number is verifiable. Do not speculate. Do not provide any names.
3. State that we are working with local emergency response agencies to rectify the problem.
4. Stress that you will release additional information as it becomes available.

Use the following do's and dont's when talking to the media.

<b>DO</b>	<b>DON'T</b>
Get a brief list of facts.	Speculate on the cause of the crisis/accident.
Be truthful.	Estimate damages.
Identify yourself as the designated project spokesperson.	Discuss identities or medical conditions of injured or missing.
End interviews promptly after giving a brief summary of the facts.	Allow reporters to sightsee or wander around the crisis site.
Advise other employees to refer all inquiries to you.	Discuss confidential information within earshot of persons you do not know.
Set up a safe, secure area where reporters can be briefed.	

### **3.0 EMERGENCY RESPONSIBILITIES**

Any employee is responsible for initiating emergency response procedures. The employee is considered the incident commander liaison until relieved.

#### **Key Areas of Responsibilities**

- Safety/Environmental
- Site Security
- Fire Protection
- Media Relations
- Communications/Personnel
- Local Emergency Response
- Transportation/Equipment
- Hospital liaison

A list of responsibilities for each area is presented below.

1. *Safety/Environmental Responsibilities*

- Be prepared to provide cardio-pulmonary resuscitation and first aid.
- Be a liaison between emergency medical respondents and the company.
- Make company safety/environmental supplies available as needed.
- Ensure appropriate measures are taken to protect the environment.
- Ensure that safe work procedures are being followed.

2. *Fire Protection Responsibilities*

- Coordinate company and outside fire-fighting forces.

3. *Communications/Personnel Responsibilities:*

- Relay messages and information by whatever means is available and necessary from an established command center.

4. *Transportation/Equipment Responsibilities:*

- Organize all vehicles for use during an emergency.
- Coordinate equipment, tools and materials that may be needed.

5. *Site Security Responsibilities:*

- Control traffic and limit site accessibility to only company or authorized personnel.

6. *Media Relations Responsibilities:*

- Respond promptly and accurately to media inquiries.
- Briefly summarize the situation for reporters, utilizing techniques learned in the company's crisis media training program.
- Contact company public affairs personnel regarding any incident which has, or could cause media attention.

7. *Local Emergency Response Responsibilities:*

- Establish temporary command center until relieved by public authorities.
- Interface with on-site incident commander (local emergency response official).

8. *Hospital Liaison Responsibilities:*

- Represent company at local medical facilities for injuries requiring hospital transport.
- Report information regarding injuries to company management.

#### **4.0 GENERAL EMERGENCY PROCEDURES**

##### **4.1 EMERGENCY REPORTING**

In the event of a hazardous/fire emergency or a hazardous substance spill, the Incident Command System (ICS) will be activated following the procedure described below:

A. The individual discovering the incident is to:

1. Notify the Control Room by radio or telephone.
  2. Give location of the emergency.
  3. Describe what is needed e.g., fire brigade, ambulance, or Emergency Medical Treatment (EMT).
  4. Give name and telephone number you are calling from.
  5. SHALL NOT break communication until directed.
- B. The Control Operator will notify the on-duty Shift Supervisor.
- C. The Shift Supervisor on duty will immediately take on the role of Emergency Coordinator, and as such he/she will become the Incident Commander responsible for coordinating all emergency response efforts. Those responsibilities include the following:
1. Complete emergency notifications.
  2. Activate internal alarms or communication systems to notify personnel.
  3. Evaluate and execute evacuation requirements, if necessary.
  4. Identify the character, exact source, amount and extent of any released material.
  5. Assess possible hazards to human health or the environment.
  6. Establish safe zones.
  7. Take all reasonable measures to ensure that fires, explosions, and releases do not occur, recur, or spread. This may include stopping processes and operations.

8. If facility stops operations, he/she will direct efforts to monitor for leaks, pressure buildup, etc., when appropriate.
9. Note in the Shift Supervisor's log the details of any incident requiring the implementation of this Contingency Plan.
10. Ensure the decontamination of reusable materials, including tools, boots, SCBAs and vehicles. All solutions used during decontamination procedures will be collected to allow proper disposal. Disposable suits and gloves will be collected and discarded in an appropriate manner.

#### 4.2 EMERGENCY TEAM NOTIFICATION

In the event of a medical, fire and or chemical emergency, the following procedures will be implemented:

- A. The Control Operator, under direction of the Emergency Coordinator, will notify the Emergency Response Team as follows:
  1. By radio, dispatch the Emergency Response Team to the scene along with Ambulance(s) and Fire Truck(s).
  2. Activate the alarm siren for 20 seconds followed by the appropriate voice announcement over the facility public address system. Do this a total of three times with an appropriate voice announcement such as:

"WE HAVE A MEDICAL/FIRE/CHEMICAL EMERGENCY ON (state specific location), ALL AVAILABLE EMERGENCY RESPONSE TEAM MEMBERS PLEASE REPORT TO (repeat specific location). ALL OTHERS STAY CLEAR."

(For chemical emergencies, have all ERT members report to the fire house.)



3. Repeat the emergency message on the facility and pipeline radio.
- B. The Emergency Coordinator, or his designated representative, will be responsible for the following notifications as appropriate:
1. Notify the Facility Nurse, or other available medical personnel
  2. Notify the Superintendent of Operations
  3. Notify the Safety/Security Coordinator
  4. Notify the Facility Representative
  5. Notify the Facility Manager

Any accident requiring the transportation of any employee to a medical facility for treatment, should be reported to the Area Superintendent or the Safety/Security Coordinator. In case of serious injuries or a fatality, notification should be made to the Facility Manager and the Superintendent of the individual involved.

- C. When the emergency situation has been resolved, the Emergency Coordinator will be responsible to notify the Control Operator that the emergency is over. The Control Operator will then make a voice announcement that the medical, chemical, and/or fire emergency is over and the area is clear.
- D. It is not necessary to evacuate an area automatically upon hearing the emergency warning. These warnings should have voice instructions. Employees in areas not affected by the emergency should continue to work.
- E. After a few hours, all Supervisors not involved with the emergency must report to the Control Room.

- F. Local Authorities: Because the pipeline and the compressor stations are located in a rural area, the Emergency Response Team, safety, and medical personnel will respond to all facility related emergencies. The Local Emergency Fire Department and the selected project medical facilities will be given copies of this plan. All hospitals in the area will be notified concerning the hazardous materials used during construction and operation of the pipeline and compressor facilities.

#### 4.3 EVACUATION PROCEDURES

If a facility evacuation becomes necessary, as determined by the Emergency Coordinator, the following procedure shall be used:

- A. The Control Operator will activate the evacuation siren. The siren will activate and operate for approximately 3-5 minutes before automatically shutting off.
- B. The Control Operator will also activate the alarm siren for 20 seconds followed by the appropriate voice announcement over the facility PA system. Do this a total of three times.

An example of an appropriate voice announcement is:

“THIS IS AN EMERGENCY EVACUATION. PLEASE REPORT TO YOUR (PRIMARY/SECONDARY) EVACUATION AREA IMMEDIATELY.”

- C. All personnel will evacuate and gather at the primary evacuation area (main parking lot of the facilities or other pre-established areas along the pipeline) and assigned areas unless otherwise directed by the Emergency Coordinator. The exception of this would be those operators that the Emergency Coordinator requests to remain to stay in the facility.

Supervisors will be responsible to account for their personnel in their assigned area, and will report results of personnel count to the their superintendent, who

will report to the Emergency Coordinator or his designee. The Emergency Coordinator will be responsible for locating missing employees.

- D. Personnel will remain at the assembly area until released by the Emergency Coordinator.
- F. Radio transmission shall be for essential use only.

#### **4.4 EMERGENCY SITE SECURITY**

During an emergency, security personnel will maintain facility and/or right-of-way security to control access of unauthorized individuals. In addition, all supervisors that are not required at the emergency site shall handle crowd control by keeping their employees in their working areas or account for and keep their employees in their evacuation area when appropriate.

#### **5.0 HAZARDOUS SUBSTANCE RELEASE RESPONSE PROCEDURES**

In the event of a hazardous material release, the Facility Representative and the Safety/Security Coordinator will assist the Emergency Coordinator by performing the following functions:

- A. The Facility Representative will be responsible for determining the environmental hazard and the degree of remedial action necessary. The Facility Representative will ensure that the outlined procedure is followed:
  - 1. Provide for treating, storing, or disposing of recovered hazardous substance and contaminated debris; and ensure that incompatible wastes are separated, and emergency equipment is cleaned before operations resume.
  - 2. Supervise the solidification and containment of the material in a manner that minimizes the danger posed to personnel and the environment.
  - 3. Ensure that the solidified material is placed in an approved drum that is properly labeled and weighed before shipment to a disposal facility.

4. If the material released was not a hazardous waste, the Facility Representative will determine the appropriate disposal method.
  5. Ensure the area is sufficiently decontaminated.
  6. Determine proper disposal requirements for wastes generated during decontamination procedures.
- B. The Safety/Security Coordinator will ensure work at the emergency site is carried out in a manner that protects the workers from heat stress and chemical exposure. He will aid the Emergency Coordinator by working with all sectors (Resource, Medical, and Hazard/Fire) to ensure safety. If the Safety/Security Coordinator is absent, the Emergency Coordinator shall appoint a Safety Officer from the Emergency Response Team. The Safety/Security Coordinator or appointed Safety Officer has the authority to alter or suspend work when activities are considered to be immediately dangerous to life and health or involves imminent danger.
- C. The chart below shows the procedures to follow when containing a spill.
1. Stop source of spill
  2. Check and close drain valve
  3. Add absorbent
  4. Build temporary berm
  5. Contain spill on site
  6. Initiate SPCC plan (at location when applicable)

## 7. Make Spill Card (notifications)

Be prepared to report the following to Spill Card contacts:

- Date and time of occurrence
- Material and quantity spilled
- Cause of spill
- Bodies of water potentially affected
- Size of affected area
- Presence or lack of sheen
- Whether the spill is off company property
- Whether the spill is under control
- Whether clean up has begun and the clean-up methods
- Whether the spill control contractor needs to be called

## 6.0 EXPLOSION/FIRE PROCEDURES

### 6.1 STATION

A. For stations without fire or smoke detection and automatic shutdown systems:

1. Sound the alarm.

2. Evacuate the building.
3. Pull emergency shutdown handle (ESD) for building, as appropriate.
4. Assemble at a predetermined location for head count and to determine course of action.
5. Call local fire department, if necessary.
6. Make notifications (go to tab 4 - *Notifications*).

B. For stations with fire or smoke detection and automatic shutdown systems:

1. The alarm system automatically sounds.
2. Evacuate the area.
3. Assemble at a predetermined location for head count and to determine course of action.
4. Call local fire department, if necessary.
5. Make necessary notifications.

## 6.2 PIPELINE

If notified by phone (otherwise proceed to step B below):

- A. Gather all critical information.
- B. Investigate pressure on system to determine whether any major changes indicate a rupture.

If pressure indicates a rupture:

1. Determine whether the pressure drop is on the suction or discharge side of the station.
2. Make notifications.
3. Dispatch personnel to appropriate valve locations to isolate and bypass the rupture, if necessary.
4. Notify appropriate purchase and sales stations. Gas Control and Measurement personnel will be available to help in this notification and shut in appropriate facilities.
5. Report all injuries and property damage to the division manager.
6. Survey the emergency site for damage.
7. If emergency repairs are required, notify the district office of the materials and equipment needed.
8. The district office will notify Gas Control and the division manager of the materials and equipment needed, as well as the time required to repair and put the line back into service.

If the pressure does not indicate a rupture:

1. Dispatch appropriate personnel to isolate gas flow, if necessary.
2. Consult local authorities regarding nature of problem.

3. Isolate valve section if emergency escalates, otherwise stand by until emergency passes.

## **7.0 GAS RELEASE/PIPELINE LEAK**

### **7.1 STATION**

A. For stations without gas detectors and automatic shutdown systems:

1. Determine source of gas leak.
2. Shut down affected engines.
3. Perform emergency shutdown (ESD) of building, if appropriate.

B. For stations with gas detector and automatic shutdown systems:

Gas detectors automatically cause building to shut down.

### **7.2 PIPELINE**

If notified by phone (otherwise, proceed to step 2 below):

1. Determine whether person making the call is safe.

If caller is safe:

Gather all critical information.

If caller is not safe:

Tell person to leave phone without hanging up, and move to a safe location. Tell person to call back from the safe location.



2. Determine location of the gas leak.

If the location of the gas leak involves a project facility:

Send a crew to evaluate the situation.

If the gas leak does not involve project facilities:

Ensure that either the gas distribution company responsible for the pipeline or the fire department is dealing with the leak. Document organization name, contact name, title, phone number, and time of discussion.

3. If company facilities are involved, make primary notifications.

## **8.0 NATURAL DISASTERS (STATION AND PIPELINE)**

If disaster is one for which warning can be given (such tornados, electrical storms and flooding) begin with step 1 below; otherwise, proceed from step 4 below:

1. Receive warning of impending disaster.
2. Secure facilities and evacuate personnel, as appropriate.
3. Notify Gas Control of impending disaster and of the actions you have taken.

If, and when, disaster strikes:

4. Assess damage.

If disaster results in ...	Go to Section
Explosion or fire	6.0
Gas detected inside or near a building/pipeline leak	7.0

5. Secure unsafe situations immediately.
6. Make notifications.
7. Return undamaged facilities back to service.
8. Repair damages.

#### **9.0 OPERATIONS WITH LOSS OF COMMUNICATIONS (STATION AND PIPELINE)**

In the event that an operating facility loses communication with Gas Control or other necessary authority, that operating facility will:

1. Attempt to hold the last given operation order until such time as temporary or normal communication can be established.
2. Under no circumstances should this operating facility exceed or allow to be exceeded the maximum operating limits (i.e., MAOP) of the facility, or adjoining pipelines.

## 10.0 EMERGENCY REPAIRS/SERVICE RESTORATION

### 10.1 PIPELINE REPAIR PROCEDURES

Extra lengths of pipe, which are tested and available for immediate installation, leak clamps and repair sleeves will be kept at strategic locations along the pipeline. The appropriate tools and equipment for installation will be maintained in proper working order and available for use. Personnel will be trained in the proper procedures for making needed repairs. The emergency repair procedures include:

- receipt of notification of an emergency at any hour on any day of the week;
- prompt and effective response to various types of incidents;
- availability of personnel, equipment, tools, and materials at the scene;
- emergency shutdown of sections of the system as necessary;
- continuing liaison with fire, police, and other appropriate public officials;
- action protecting people and then property from any existing or potential hazard;
- safe restoration of service;
- investigation of incident;
- training of personnel; and
- distribution of plan.

Implementation of the plan will be the responsibility of the location manager/supervisor. Location managers/supervisors will coordinate activities so that assistance or "first response" can be provided by an adjacent location if the emergency is more closely located thereto.

## **10.2 RESTORATION OF PIPELINE SERVICE**

Generic instructions for the restoration of service for a pipeline valve section follows:

1. Inform Gas Control of plan to return to service.
2. Properly position all side valves.
3. Purge valve section per O & M Procedure.
4. Notify Gas Control and adjoining districts of intention to load valve section.
5. Load valve section per O & M Procedure.
6. Check for leaks at all mechanical connections (flanges, unions, threaded connections).
7. Open mainline valves.
8. Notify Gas Control of time returned to service.
9. Position side valves and bring on producers and/or customers as appropriate.
10. Verify that applicable relief valves or other over pressure protection devices are in service.
11. A more specific procedure may have to be developed before returning a pipeline section to service.