

ENVIRONMENTAL CAMEROON PORTION

MANAGEMENT PLAN

... APPENDIX VI

Chad

E-202

VOL. II

Export

Project

Appendix VI

BP/SE/H-Related Project Specifications

⇒ Job Specification Coordination Procedures (JSCP):

- JSCP 19 Changes in Work / Deviations from Job Specifications
- JSCP 22 Project Safety Practices
- JSCP 23 Occupational Health, Medical Facilities, and Sanitation
- JSCP 27 Training
- JSCP 29 Socioeconomic Interactions
- JSCP 30 Environmental Management
- JSCP 31 Interface Management

⇒ General Project Specifications (GPS):

- GPS-001 Camps and Facilities
- GPS-002 Catering Services
- GPS-003 Potable Water Treatment, Storage, and Distribution (Temporary)
- GPS-004 Packaged Sewage Treatment System (Temporary)
- GPS-005 Water Wells (Temporary)
- GPS-006 Waste Incinerator (Temporary)
- GPS-007 Non-Hazardous Solid Waste Landfill
- GPS-008 Project Safety Requirements
- GPS-010 Health Plan
- GPS-011 Waste Management
- GPS-012 Socioeconomic Action Plan
- GPS-018 Septic Tank and Effluent Disposal into Drainage Field (Temporary)
- GPS-020 Survey Camps and Facilities
- GPS-021 Survey Catering Services

⇒ Cameroon/Chad Specifications (CCS):

- CCS 7-1-10 Waste Incinerator
- CCS 11-10-1 Water Wells
- CCS 11-10-2 Potable Water Treatment, Storage, and Distribution
- CCS 11-11-1 Packaged Sewage Treatment System
- CCS 13-4-1 Solid Waste Landfill
- CCS 21-20-107 Soil Erosion Mitigation
- CCS 21-20-108 Environmental Impact Mitigation

This document is available in English only.

CHANGES IN WORK/DEVIATIONS FROM JOB SPECIFICATION

1.0 Scope

This section sets forth Esso's minimum requirements for processing requests for changes in the Work or deviations from the Job Specification.

2.0 Contractor's Duties

Contractor's principal duties with respect to initiating and processing change or deviation requests and implementing Change Orders or Job Specification deviations shall include:

- 2.1 Preparing, maintaining and implementing a Change Management Plan which includes procedures covering all aspects of processing change/deviation requests and change/deviation proposals and implementing Change Orders or Job Specification deviations for the Work.
- 2.2 Initiating a request for a revision to or deviation from the Job Specification on a timely basis. This would include requests that, if implemented, would benefit the overall execution of the Work.
- 2.3 Responding within seven (7) calendar days to a request from Esso for an estimate of the effect, if any, that the following will have upon the Contract Price and/or Scheduled Completion Date:
 - 2.3.1 A proposed revision to or deviation from the Job Specification.
 - 2.3.2 Other circumstances identified in Article 7 of the Principal Document for which a Change Order is allowable.
- 2.4 Implementing revisions to or deviations from the Job Specification when authorized by Esso.

3.0 Contractor's Change Management Plan

Contractor's Plan shall be issued within thirty (30) calendar days after date of Contract. The Plan shall include procedures for initiating and processing requests for Change Orders or deviations, as well as implementing authorized Change Orders or approved deviations, shall include a detailed description of:

- 3.1 How change/deviation requests will be initiated.
- 3.2 The preparation of change/deviation proposals by Contractor, and the schedule for their completion and submission to Esso.

- 3.3 The methodology for recording and tracking change/deviation requests, change/deviation proposals and Change Orders / deviation approvals.
- 3.4 How revisions to or deviations from the Job Specification will be implemented when authorized by Esso.
- 3.5 The forms that will be used in the entire process, including a sample of each.

4.0 Procedural Requirements

Contractor's procedures for initiating and processing change/deviation requests and implementing Change Orders or approved deviations shall incorporate the following requirements of Esso, at a minimum:

- 4.1 Contractor (or Esso) may initiate a request for a revision to or deviation from the Job Specification. However, Contractor shall obtain Esso's approval to initiate a change/deviation request prior to expending any engineering, cost estimating, scheduling or other effort in support of it. If accepted, Esso shall issue a change/deviation request to Contractor. The change/deviation request shall include:
 - 4.1.1 A brief description of the proposed revision/deviation to the Job Specification including the safety and environmental implications and the required Contractor's services.
 - 4.1.2 An identification of who initiated the change/deviation request (e.g., Esso, Contractor) and the reason for the change/deviation request (e.g., safety, operability, Esso preference, investment return).

Contractor shall assign a Change Order number to each change request and enter it into the Change Order log (4.6 below) at the time that it is issued. Deviation requests shall similarly be assigned a number and entered in the deviation log (4.6 below).

- 4.2 Contractor shall respond to a change/deviation request by submitting a completed change/deviation proposal to Esso within seven (7) calendar days of the initial request. If Contractor determines that the change/deviation proposal cannot be completed within seven days, Contractor shall promptly advise Esso of that fact, the reason for the delay and the date that the change/deviation proposal will be available for Esso's review. The change/deviation proposal shall include:
 - 4.2.1 The effect, if any, on the Contract Price with subtotals in the components of the Contract Price specified in Exhibit A of the Principal Document. The estimated effects shall be supported by accompanying backup data which clearly define how the subtotals were developed.

- 4.2.2 The effect, if any, on the Scheduled Completion Date with appropriate accompanying backup data.
- 4.2.3 A statement regarding the effect of the proposed change/deviation, if any, on Contractor's guarantees.
- 4.2.4 The effect, if any, on process or utility requirements.
- 4.2.5 The cost to process a Change Order shall be separately identified for each Change Order.
- 4.3 Contractor shall use unit and/or all inclusive rates from the Contract in preparing the change/deviation proposal in order to: (i) minimize the time required for estimating; and (ii) to facilitate Esso's review of the proposal. Where rates do not exist, Contractor shall propose a new rate based on rates for similar activities already included in the Contract, when applicable.
- 4.4 If Esso authorization to proceed with the revision to or deviation from the Job Specification has not accompanied the change/deviation request, the change proposal shall include the latest date such authorization can be given without further affecting the Scheduled Completion Date.
- 4.5 Esso will issue the Change Order or deviation if it agrees to implement the requested change/deviation.
- 4.6 Contractor shall maintain separate Change Order and deviation logs of approved and pending changes/deviations that shall include: the Change Order or deviation number, a brief description of the change/deviation, the date that the change/deviation request was received by Contractor, the date that the change/deviation proposal was submitted to Esso, the date that it was approved or rejected, the action taken by Esso (approval or rejection), the effect upon the Contract Price and Scheduled Completion Date, and any remarks. The logs should be maintained in a comprehensive database for easy sorting and retrieval. Contractor shall keep the logs current and include a summary of them in its monthly progress report as defined in the Change Management Plan agreed with Esso.
- 4.7 Esso's authorization for Contractor to perform Work associated with a change/deviation will normally accompany the approved deviation or Change Order. However, Esso may authorize Contractor to perform part or all of the Work associated with the change/deviation at the time that it issues the change/deviation request.

PROJECT SAFETY PRACTICES

1.0 Scope

This section sets forth Esso's minimum safety requirements of Contractor during the execution of the Work.

2.0 General

- 2.1 This procedure in conjunction with the Project Safety Requirements, GPS-008, have been prepared to assist each project Work Site employer/Contractor in satisfying its moral, contractual, and legal accident prevention responsibilities, in such a manner that a safe, efficient operation is assured. For additional advice and assistance each employer should consult with its safety organization, insurance carrier or similar available source.
- 2.2 Esso at all levels is dedicated to assuring that its employees and others are provided a safe and healthy place to work on each of its projects.
- 2.3 The safety goals and objectives that Esso has established for the project are as follows:
- Incur zero fatalities, zero lost time injuries and zero recordable accidents/incidents for all Work Sites and the promotion of off-the-job safety;
 - Incur no long term debilitating occupational related illnesses and minimize short term illnesses associated with work activities and job site locations through a proactive medical and health program;
 - Limit personnel injuries and other losses due to emergencies through an Emergency Preparedness and Response Plan;
 - Prevent recurring accidents/incidents through a program of a Root Cause Analysis and lessons learned.
- 2.4 Contractor shall develop and maintain a safe working environment and institute a safety program aimed at eliminating accidents, injuries and property damage at the Work Site.
- 2.5 The safety, medical rules and regulations contained herein are not all inclusive. OSHA, EPA, ANSI, MSHA and ACGIH standards not specifically referenced in these rules and regulations shall apply as minimum safety and health requirements as applicable to Chad and Cameroon. The use of alternative standards, which meet or exceed these minimum requirements, shall be submitted to Esso for review and approval.
- 2.6 This material must not be considered to be all inclusive as to the hazards that might be encountered, safety practices that should be performed, or safe conditions that should be maintained during the course of this project.

- 2.7 All line managers, supervisors and foremen of Contractor and its Subcontractors share in Contractor's responsibility for the safety of their personnel at the Work Site and shall make safety the highest priority of their day-to-day work assignments.

3.0 Importance of Safety

- 3.1 The first consideration for all Contractors and their Subcontractors is the safety and health of their employees through all phases contracted. It is Contractor's responsibility to ensure that all of its employees are fully aware of the safety requirements on the site and to conform to same.
- 3.2 Esso cannot and will not relieve or accept liability for any Contractor or Subcontractor in regard to safety responsibility to its employees. Each Contractor must enforce and each of its employees must comply with the safety regulations and standards established on this project.

4.0 Contractor's Organization

- 4.1 Contractor shall assign a qualified, full-time safety advisor to coordinate all of the safety activities of Contractor and its Subcontractors at the Work Site. The safety advisor shall report directly to Contractor's Project Manager and not to anyone else with direct responsibility for construction. The safety advisor shall be present at the Work Site on a full-time basis from the time that Contractor begins construction operations until Contractor leaves the Work Site. Contractor's safety advisor shall provide leadership for Contractor's safety program and advise Contractor's line management at the Work Site, who remains responsible for the safety of their personnel on the project.
- 4.2 Contractor shall designate a safety representative who will coordinate with Esso's safety advisor or Regional Safety Office. Contractor safety representatives will attend all meetings pertinent to safety, medical, security or fire information presented by Esso.
- 4.3 Contractor safety representatives shall also conduct a safety orientation with all Subcontractors to ensure that the safety requirements are fully understood and complied with.
- 4.4 Contractor shall submit to Esso a detailed description of its safety organization for the project, the identity of the assigned safety advisor and assistant safety advisors, and a detailed description of their assigned duties including safety advisor's qualifications. This information should be submitted along with the Contractor's overall project construction organization required by 2.2 of Section 1.

5.0 Contractor's Duties

Contractor's principal duties with respect to Safety shall include:

- 5.1 Instructing each employee on the Work Site in the recognition and avoidance of unsafe acts and/or conditions applicable to the work environment to control or eliminate injury and/or illness. Contractor shall enforce the project and statutory safety rules with its employees.
- 5.2 Providing and requiring the use of appropriate personal protective equipment in all operations where there is an exposure to potentially hazardous conditions or materials. All records shall be maintained at a location accessible to Esso.
- 5.3 Notifying Esso of any hazardous chemicals or substances that are brought to the Work Site. Contractor shall provide Esso with a copy of Contractor's Hazardous Communication Program and the Material Safety Data Sheet(s) (MSDS) for the chemical(s) or substance(s) intended for use on the site. A bookcase, centrally located, should be dedicated for this information. Contractor is responsible for maintaining a copy of Contractor's Hazardous Communication Program and Material Safety Data Sheet(s) on site for Contractor's own reference and employee training. The legal storage, use and disposal of wastes of any hazardous chemicals or substances is the responsibility of Contractor in accordance with Contractor's Waste Management Plan.
- 5.4 Developing, publishing and enforcing appropriate work standards and safety rules for the Work Site, including a Alcohol and Drug Use Policy pursuant to GPS-008, Appendix II and in accordance with the Alcohol and Drug Use Policy stated in Article 13, Principal Document.
- 5.5 Developing a program for the safe use and storage of explosives. This program must meet the minimum requirements outlined in OSHA 1926.900 and 1926.914.
- 5.6 Developing a fire protection and prevention program conforming to Section 24, Coordination Procedure. Contractor shall also comply with all fire and safety rules and regulations established on the project.
- 5.7 Preparing, maintaining and implementing a safety execution plan for the Work Site.
- 5.8 Preparing, maintaining a detailed, site specific safety manual for the project.
- 5.9 Developing and conducting a safety indoctrination and training program to instruct the work force in maintaining safe working conditions, in following safe construction practices and in improving their safety awareness.
- 5.10 Conducting accident and incident investigations and analyses; issuing reports of the investigations and analyses to appropriate parties.

- 5.11 Utilizing OSHA standards as the minimum safety requirements for the project. Any Work Site safety regulations which exceed the minimum standards established shall be incorporated into Contractor's safety program.
- 5.12 Before starting work at the Work Site, attending a pre-construction meeting with Esso to understand the project conditions and safety requirements. A Work Site tour shall be made to confirm Contractor's awareness of potential safety hazards. Appropriate methods, equipment, devices and material shall be provided by Contractor to assure a safe work place. Contractor shall provide or develop its own project specific safety program and submit it to Esso for review prior to starting work at the Work Site as per 6.1 of this Section. Such review shall not relieve Contractor of its responsibility for safety, nor shall such reviews be construed as limiting in any manner. It is Contractor's obligation to undertake any action which may be necessary or required to establish and maintain safe working conditions at the Work Site.

6.0 Contractor's Safety Execution Plan

- 6.1 Contractor shall submit its safety execution plan to Esso for its review and approval within six (6) months after date of Contract, but not later than four (4) months prior to field mobilization.
- 6.2 As the project progresses, Contractor shall constantly evaluate the effectiveness of its safety execution plan and propose to Esso appropriate modifications to it.
- 6.3 The safety execution plan shall address at the minimum the topics shown in the following typical Table of Contents for such a plan and shall discuss the actions and processes that will be used to achieve the safety standards including identification of responsible parties. The plan's elements shall also address the following:
 - 6.3.1 Discussion of the approval process and milestones for deliverables as applicable,
 - 6.3.2 A mechanism for monitoring and enforcing compliance with the plan, including responsibilities of Contractor auditors, interaction with Esso, implementation of remedial actions to resolve deficiencies, and documentation of management approval of remedial actions,
 - 6.3.3 A process for resolving conflicts between the objectives of safety and construction personnel,
 - 6.3.4 Reports on safety performance that will be provided to Esso,
 - 6.3.5 Procedures for managing change of personnel/organizations responsible for a task,

6.3.6 Provisions for incorporating improvements to the safety program.

CONSTRUCTION SAFETY EXECUTION PLAN

TYPICAL TABLE OF CONTENT

Introduction

Purpose of Plan

- Objectives
- Esso's Safety Philosophy and Policy
- Contractor's Role

Safety Considerations in Subcontracting

Safety Screening

- Invitations to Bid
- Bid Review

Construction Safety Planning

General Requirements

- Site Safety Manual
- Training and Indoctrination
- Ordering Safety Materials
- Heavy Lifts
- Construction Tools and Equipment
- Layout of Temporary Construction Facilities
- Work Permits
- Air Transportation Safety for On Site Aircraft, ie; Approaching Running Aircraft, Loading & Unloading
- Driver Education and Training; Safe Driving Enforcement
- Safe Handling and Storage of Explosives
- Industrial Hygiene

Construction Site Activities

Responsibilities

- Safety Indoctrination
- Alcohol and Drug Use Program and Responsibilities
- Publicity
- Safety Incentive Programs/Motivation
- Job Safety Analysis
- Safety and Health Meetings
- Management Meetings
- Workers' Meetings
- Site Safety Inspections and Audits

- Personal Protection Equipment
- Accident Investigation, including Root Cause Analysis
- Safety Reporting/Record Keeping
- Process Safety Management of Highly Hazardous Chemicals
- Work Site Hazard Communication Program (HAZCOM)
- Multi-Lingual Training, Signs and Manuals.

Industrial Hygiene

- Hazard Communication (Right To Know)
- Employee Exposure and Medical Records
- Applicant Medical History
- Medical Examinations
- Respirators
- Respirator Wearer Medical Qualification
- Breathing Air Quality
- Noise
- Asbestos Handling Procedures
- Heat Stress
- Pre-Employment History and Partial Physical
- Radiation Control
- Alcohol and Drug Use Policy
- Process Safety Management
- Lead Exposure

7.0 Procedural Requirements

- 7.1 Any work standards, safety rules, or safety procedures and reporting forms which Contractor develops for the project shall incorporate appropriate provisions of, and be consistent with, applicable Esso safety regulations and documents.
- 7.2 Contractor's site specific safety manual shall include the work standards, safety rules and the detailed safety procedures for the Work Site. Contractor shall submit the completed manual to Esso for its review and agreement six (6) months after date of Contract but not later than four (4) months prior to field mobilization and prior to distributing it to supervisors and workers at the Work Site. The safety manual should be written in the local language, and/or other language(s) designated by Esso.
- 7.3 The safety manual shall be distributed to all Contractor and Subcontractor supervisors upon arrival at the Work Site. An abridged version of the safety manual (the contents of which is to be agreed by Esso prior to publication) may be developed by the Contractor and distributed to other workers at the Work Site. Otherwise, individual workers shall be issued the same safety manual that the supervisors receive.

7.4 Contractor's site specific safety manual shall address the following topics as a minimum:

- Esso's safety philosophy and policy
- Contractor's safety policy
- Contractor's safety organization
- General safety rules; general behavior required of workers at the Work Site
- Safety orientation, safety training and safety motivation programs
- Site medical facilities, provisions for medivac ambulances, doctors, hospitals, etc., for handling emergencies beyond site treatment capability
- Fire protection
- Security procedures
- Traffic regulations
- Use of personal protective equipment and clothing
- Fall protection
- Industrial hygiene
- Cranes and lifting equipment; conduct of critical and heavy lifts (defined as those lifts in excess of 50 tons, those which exceed 75% of the capacity of lifting equipment being utilized, those requiring two or more pieces of equipment operating in unison, those conducted over process piping, electrical instrument cable trays, live or sensitive operating equipment, and those lifts requiring special lifting gear such as helicopters or ginpoles.)
- Minimizing the number of personnel working in any one area, or above one another, at the same time.
- Use of man baskets and boatswains chairs
- Excavations
- Working near or around water
- Rules for dealing with specific potential hazards including operation of potentially hazardous tools, machinery and equipment, such as: electrical tools, construction vehicles and motorized equipment, welders and grinders

- Hot and cold work permit procedures
- Entry into confined spaces
- Lockout and tagout of electrical and mechanical equipment
- General blanking procedures; blanking of piping and other safeguards during construction near operating units, testing and commissioning
- Housekeeping, to include marking and isolating potential hazards
- Safety inspections of construction equipment and vehicles
- Emergency procedures and site evacuation plan, including emergency signals and responses thereto
- Ionization radiation
- Welding and burning
- Emergency response to hazardous release
- Hot tap procedures
- Minimum requirements for provision of temporary power
- Location/layout of temporary buildings
- Demolition/removal of equipment and facilities

8.0 Instruction and Training

Contractor's safety indoctrination and training program shall be in languages understood by the workers and shall incorporate the following elements.

- 8.1 A safety indoctrination session for each visitor and worker of Contractor, Esso and Subcontractors, prior to the time the person begins work or visits at the Work Site. The indoctrination will:
- (i) Acquaint the employee or visitor with Esso's prioritized project objectives.
 - (ii) Acquaint the employee or visitor with the Work Site, the nature of the Work, the hazards that the employee or visitor may encounter, and the work standards and safety rules that must be followed to eliminate accidents, injuries and incidents on the Work Site.

(iii) Distribute the appropriate safety manual for the Work Site and review its contents, stressing those sections applicable to the employee and his/her job.

(iv) Advise the employee of the requirements for working safely, and that failure to follow safety rules may result in disciplinary action, including dismissal.

- 8.2 Appropriate safety instructions for each worker of Contractor and its Subcontractors from his/her supervisor with every work assignment.
- 8.3 Development of a safe working plan for each new work assignment which shall be analyzed for potential hazards using the Job Safety Analysis procedure as outlined in the Project Safety Requirements, GPS-008. This Analysis shall be used as the basis for providing safety instructions.
- 8.4 Contractor shall assess the effectiveness of the training and record methods used to make the assessment.
- 8.5 A record shall be kept of all personnel who undertake safety indoctrination and training.
- 8.6 Instruction and training of employees will be required on this project. Examples of such required training to be provided by Contractor are:
- Indoctrination - Newly employed, promoted and/or transferred personnel shall be verbally instructed in the safety practices required by their work assignments.
 - Work Assignments - All work assignments must include specific attention to safety. Follow-up monitoring is required in order to prevent accidents.
 - Meetings - Properly conducted and recorded weekly craft "tool box" safety meetings are required.
 - Specific Instructions - Employees performing specific tasks or operating specific equipment shall be properly trained.
 - Job site visitors shall receive indoctrination for specific hazards that may be encountered at each Work Site.

9.0 Record Keeping

A log of safety activities, accident investigations, employee instruction, training, "tool box" meetings, etc., shall be maintained on Work Site and copies shall be promptly provided to Esso upon request.

10.0 Fire Prevention

Contractor shall be responsible for fire protection in its work and operational areas, including offices, tool rooms, and storage areas twenty-four (24) hours per day, seven days per week through the duration of the Contract. Approved fire fighting equipment in adequate quantities must be provided by Contractor, and its employees must be trained in the usage of such equipment per Section 24 of the Coordination Procedure.

11.0 Third Party Safety Inspections

In addition to visits and safety inspections by its own corporate and/or insurance representatives, Contractor is advised that the Project may be inspected from time to time by authorized third parties. Among others so authorized are representatives of Esso, insurance companies and enforcement authority. Upon their proper identification, they are entitled to access and courteous consideration. Esso shall be made aware, if possible upon their arrival, but in any case as soon as possible for the purpose and results of such visits which relate to safety.

12.0 Emergency Preparedness and Response

Contractor will provide to Esso for review and approval ninety (90) calendar days prior to field mobilization, an Emergency Preparedness, Response and Contingency Management Plan per Section 6 of GPS-009 and Section 25 of Coordination Procedure for evacuation of the work area in the event of a natural disaster and/or project emergency. Contractor will be responsible for advising its employees of the emergency signals and primary evacuation route.

OCCUPATIONAL HEALTH, MEDICAL FACILITIES AND SANITATION

1.0 Scope

This section sets forth Esso's minimum requirements of Contractor for implementing a health program including Contractor's camps, food services and other temporary facilities, as well as for providing the required medical and sanitation facilities and services.

2.0 General

Contractor's occupational health and medical program shall be in compliance with all applicable regulations and be consistent with Esso's Health Plan and Medical Service Guidelines for Remote Sites, GPS-010, included in this Job Specification.

In addition, Contractor shall comply with Specifications for Camps and Facilities; GPS-001; Catering Services, GPS-002; Water Wells, GPS-005; Potable Water Treatment, Storage and Distribution, GPS-003; and Packaged Sewage Treatment System, GPS-004.

Plans and procedures relating to this section of the Coordination Procedure document are to be submitted to Esso for approval within six (6) months after date of Contract or three (3) months prior to in-country mobilization whichever is sooner.

3.0 Contractor's Organization

- 3.1 Contractor shall retain, for each Work Site, a health/medical supervisor who shall be responsible for implementing Contractor's health program.
- 3.2 Contractor shall engage a consulting physician, trained in the United States, Canada or Western Europe with special training and experience in vector-borne and infectious medicine, to provide advice on medical supplies and equipment to be maintained, selection of medical attendants, appropriate procedures for the evacuation and care of employees requiring hospitalization or specialized treatment, and to advise on field sanitation.
- 3.3 Contractor shall identify its safety, health, and environment manager, health/medical supervisor and consulting physician and provide a detailed description of their qualifications (resumes and affiliations) and assigned duties to Esso with Contractor's overall project Work organization required by Paragraph 2.2 of Section 1 of this Coordination Procedure.

4.0 Contractor's Duties

Contractor's principal duties on the project with respect to health, sanitation and medical facilities and services shall include:

- 4.1 Developing, publishing and enforcing project health and sanitation standards for the Work Site and camp area that meet or exceed those described in Esso's "Health Plan" and "Medical Services Guidelines for Remote Sites".
- 4.2 Preparing, implementing and maintaining a plan for providing the required health, sanitation and medical facilities and services for the work force (including Esso representatives associated with Contractor's operations).
- 4.3 Complying with Esso guidelines (reference Section 22 of this Coordination Procedure) and relevant Government regulations regarding safe handling of toxic materials and hazardous chemicals and other work practices. Although local or regional regulations may take precedence, project health and safety standards shall be applied as a minimum.
- 4.4 Providing, with Esso's prior review, qualified medical attendants, space, equipment and supplies to provide first aid, medical treatment and triage for industrial injuries, illness or exposure to chemicals or other toxic substances that may occur.
- 4.5 Providing adequate health education for the project work force (including Esso representatives associated with Contractor's operations).
- 4.6 Providing employees with prophylaxis and inoculations against specific diseases, as appropriate.
- 4.7 Providing emergency medical evacuation, as appropriate, for Contractor, Subcontractor, Vendor personnel. Esso will provide emergency medical evacuation for Esso representatives.
- 4.8 Consulting with Esso on health regulations and inspections required by governmental authorities.
- 4.9 Detecting, reporting to the onsite Esso representative and removing un-healthy or environmentally unsound conditions or hazards under Contractor's control.
- 4.10 Maintaining appropriate health, medical and sanitation records; preparing and issuing required health, medical and sanitation reports as requested by Esso.
- 4.11 Ensuring that food services workers are medically certified for food handling and preparation. Minimum standards for the organization of food services and certification requirements for food handlers are available in the Catering Services Specification, GPS-002.
- 4.12 Evaluating those persons with detected contagious diseases and taking necessary actions so that epidemics are not triggered in the rest of the work force. These persons may be returned to work only after receiving proper medical clearance. In the event of any outbreak of illness of an epidemic nature, Contractor shall comply

with and carry out such requirements as may be made by the Government, the local medical or sanitary authorities, and Esso for the purpose of dealing with and overcoming the same.

- 4.13 Providing clean, disease free camp facilities for Esso and Contractor employees. Minimum standards for camp operation are presented in Camps and Facilities Specification, GPS-001.
 - 4.14 Developing disease prevention and surveillance programs for utilization at the project site. The prevention programs shall include regularly scheduled treatments to prevent the breeding of insects and vermin, particularly those associated with vector-borne diseases. Maintaining records of such treatment. This program should be developed by Contractor's consulting physician described in Paragraph 3.2.
 - 4.15 Providing sufficient potable water for all site personnel (including Contractor and Esso employees and authorized visitors). Testing water for organic and inorganic pollutants initially and at the completion of its operations at a given site, (at a minimum) and testing for micro-biological pollutants at least weekly. Recording results. Testing for pollutants shall be carried out using methods in Standard Methods for the Examination of Water and Wastewater (Mary Ann H. Franson, editor, American Public Health Association, 1995). Minimum standards for potable water are discussed in the Potable Water Supply and Distribution Specification, GPS-003.
 - 4.16 Disposing of all wastes, including domestic waste water, in conformance with Esso's Waste Management Requirements, GPS-011 included in this Job Specification.
 - 4.17 Cooperating with and assisting Esso medical representatives conducting inspections and audits of Contractor's occupational health, medical and sanitation performance, monitoring, and reporting. Implementing corrective and preventive actions recommended by Esso as necessary to ensure Contractor fulfills the scope and intent of the Contract.
- 5.0 Contractor's Occupational Health, Medical Facilities, and Sanitation Plans
- 5.1 Contractor shall submit its health, medical facilities, and sanitation plans to Esso for approval within six (6) months after date of Contract or three (3) months prior to in-country mobilization whichever is sooner. The plans shall be revised and re-submitted, as necessary, in order to receive Esso approval prior to in-country mobilization.
 - 5.2 As a minimum, the plans shall describe how Contractor proposes to discharge the duties set forth in Paragraph 4.0 above, and shall also include the following topics:

- 5.2.1 Actions and processes that will be used to achieve project health/medical objectives.
- 5.2.2 Organization charts and resumes of personnel that will organize and manage the health/medical program.
- 5.2.3 Scheduled dates for deliverables.
- 5.2.4 Mechanism for monitoring and enforcing health/medical responsibilities of Contractor and proposed methods for interacting with the Esso medical staff.
- 5.2.5 Process for resolving conflicts between medical and construction personnel, goals, schedules, deliverables, or procedures.
- 5.2.6 Procedure for incorporating change to the health/medical plan.
- 5.2.7 Layout of temporary facilities including construction camps, washrooms, toilets and similar facilities, and catering services to conform to accepted health and sanitation principles and in accordance with applicable governmental regulations and relevant project specifications.
- 5.2.8 Medical attendants, facilities, equipment and supplies that Contractor proposes to provide to comply with the Contract.
- 5.2.9 Method of treatment and/or evacuation of workers who have experienced an injury or illness, or have been exposed to harmful chemicals or other toxic substances.
- 5.2.10 Health education training program for Contractor's workers. At least ten (10) percent of Contractor's work force shall be trained in first response level first aid. Each work area should have, at a minimum, one first aid trained worker.
- 5.2.11 Health, sanitation and medical records that will be maintained and the frequency, format and content of such reports that will be submitted on the project to comply with the Contract.

6.0 Procedural Requirements

Contractor's occupational health, medical facilities and sanitation programs shall incorporate the following requirements, at a minimum:

- 6.1 Contractor shall provide transportation of personnel who are taken ill or injured to an approved hospital or other suitable medical facility for further treatment when required.

- 6.2 Contractor shall conduct regular inspections of its facilities to ensure that they are being maintained in a healthy, clean and sanitary condition. Contractor shall immediately investigate all potentially serious illnesses and injuries that occur to determine if their cause is work related, and to prevent them from recurring or spreading.
- 6.3 Contractor shall conduct monthly formal training programs for the work force to inform them of the health and environmental hazards and of Contractor's health program.
- 6.4 Contractor shall prepare documentation as described below, keep these records for three (3) years after Acceptance, and make all documentation available for review at the request of Esso.
 - 6.4.1 Medical attendants shall record all cases seen or treated by them. Records shall include the identification of the worker, date and nature of the injury or illness, treatment provided, further care recommended and any work restrictions caused by the injury, illness and/or treatment.
 - 6.4.2 Contractor shall maintain routine health and sanitation records, such as the results of pre-employment physical examinations, individual employee record of injury or illness, results of medical examinations of food handlers, results of Work Site sanitation inspections, measures taken to control vermin or pests and trend analyses of injuries and illness based on standard WHO Panel of Experts on Environmental Management for Vector Control (PEEM).
 - 6.4.3 Contractor shall immediately notify Esso of a fatality, an injury or illness that requires hospitalization, or a possible lost time injury, as per Section 25 of Project Safety Requirements, GPS-008.
 - 6.4.4 Contractor shall maintain weekly and monthly logs of all occupational injuries and illnesses, including first aid cases, and submit them to Esso for review by the tenth of the following month.
- 6.5 Contractor shall develop and implement a Work Site Hazard Communication Program (HAZCOM) as per Section 22 of this Coordination Procedure. It shall address exposure to and handling of potentially toxic and hazardous materials. It shall also include provisions for container labeling, collection and availability of Material Safety Data Sheets, and appropriate training programs to ensure that all employees are informed of Work Site hazards. Provisions for maintaining up-to-date Material Safety Data Sheets (MSDS) for chemicals brought on site during the Work shall also be included.

- 6.6 Contractor shall develop industrial hygiene procedures for work that entails health hazards, as per Section 22 of this Coordination Procedure.

TRAINING

1.0 Scope

This section sets forth the minimum component of the development of a competent national/local work force. This development effort is to include the craftsmen, foreman, supervisors, and support personnel. It shall be the responsibility of Contractor to develop and administer a Training Program to meet the training requirements of the Work force. Some of these requirements are described in this Section.

2.0 Definition

For the definition of a National and a Local, see Section 29 - Socioeconomic Interactions.

3.0 Contractor's Training Plan

Contractor shall submit to Esso for review and approval within ninety (90) calendar days after date of Contract, a Training Plan which includes:

- 3.1 An organization chart and associated mobilization schedule for Esso's review and approval of personnel assigned to the training efforts. The minimum standard shall be one (1) trainer and one (1) trainer aide per one hundred (100) trainees, The Training Program is to be staffed with one (1) manager, one (1) curriculum coordinator, one (1) secretary and one (1) placement coordinator per 500 trainees and one (1) recruiter.
- 3.2 Recruiting and placement plans for national/local hires. Contractor shall document their recruitment efforts in their hiring practices and training program and have this documentation available for review by Esso.
- 3.3 A comprehensive description of all planned training including environmental, safety, craft, fire protection, health, the associated training schedule and refresher training. Descriptions shall include course content, course attendees, testing, assessment and verification methods.
- 3.4 A description of the training tracking program and the records system which documents all employee orientation and construction training assuring compliance with the minimum training requirements and local, regional, and host country laws and regulations.
- 3.5 Cultural Orientation

Contractor shall ensure that training orientation is both consistent with Esso standards and incorporates cultural norms of national/local hires. Safety, health

and environment is more a result of worker values than mastering facts. The Contractor must ensure workers have learning material that has the potential of changing values associated with performance.

4.0 Contractor's Duties

- 4.1 Contractor shall mobilize the Training Program thirty (30) days prior to start of Construction.
- 4.2 Contractor shall develop and implement a Training Program which provides for a minimum of ten (10) hours of Safety, Security, Cross Cultural/Community Awareness and Environmental training for each employee during employment orientation. The program shall also implement continuing Safety, Security, Cross Cultural/Community Awareness and Environmental training for the duration of the Contract. The health and safety orientation training applies to all Project employees and visitors at the Work Site including Contractor, Subcontractor, Vendor and Esso personnel.
- 4.3 Contractor shall devote forty (40) hours to basic craft skills and work process orientation training for unskilled labors and/or craftsmen. At the conclusion of the forty (40) hours of training, Contractor shall evaluate the labors'/craftsmen's progress and assign those who are qualified to on-the-job training (OJT). Those who do not qualify are to be assigned to a maximum of 120 hours of skills development.
- 4.4 Contractor shall implement a minimum of twenty (20) hours of high skills orientation in the Training Program for skilled and semi-skilled national/local hire which includes craft training and certification for helpers, craftsmen and foremen.
- 4.5 Contractor shall pay the national/local hires prevailing wage during their participation of the approved Training Program.
- 4.6 Contractor shall demonstrate on-the-job-training (OJT) which results in advancement and promotion of national/local hire craftworkers.
- 4.7 Contractor shall maintain a file on each national/local hire which will include performance evaluations, evaluation schedule, certification, and promotion record. This information is to be made available to Esso to be used in the identification of potential operations and maintenance personnel and to provide periodic feedback to employee on his performance in the areas of skills, safety, health and environment.
- 4.8 Contractor shall maintain a file of Training Program compliance with local, regional and country labor laws and regulations. Record of compliance shall be made available to Esso upon request.

- 4.9 Contractor shall conduct a survey of labor availability prior to construction startup within the regional area of their work responsibility to determine the availability of skilled/unskilled labor and make available to Esso the results/conclusions of this survey. Contractor shall maintain a file demonstrating compliance in conducting a labor survey.
- 4.10 Contractor shall develop a craft work force profile for each regional area of their work responsibility. This information is to be used in the development of the Training Plan.
- 4.11 Contractor shall provide training facility(s) which is to be equipped with the standard tools and materials needed to provide training in those crafts germane to its Contract. Each training facility shall have a minimum of 30 square meters of classroom space for a maximum of 20 trainees per classroom session. Each facility shall be equipped with a minimum class "C" furniture and typically include a video recorder (VCR), television, overhead projector and white board (1.5m by 4.5m). Class "C" furniture is described as folding chairs or bucket seats, folding tables or nonfolding tables and metal instructors desk and chair.
- 4.12 Contractor shall supply each trainee, including helper, craftsman, and foreman, an industry standard basic tool kit of the craft in which the trainee is receiving training.
- 4.13 Contractor shall supply each worker/trainee a full set of work clothes including safety shoes, socks, trousers, and shirt to be worn while working on a Project Work Site. Contractor has the option of issuing clothing or using change rooms; regardless, Esso requires the allocation of only one (1) pair of safety shoes, three (3) pairs of socks, two (2) trousers and three (3) shirts annually per worker. The clothing to be supplied shall be approved by Esso.
- 4.13 In addition to the requirements of this section, Contractor shall incorporate the specific training requirements specified in the following Sections of the Coordination Procedure and the referenced General Project Specifications:

Safety Training	Section 22 (GPS-008)
Health Education Training	Section 23 (GPS-010)
Fire Prevention Training	Section 24
Security Force Training	Section 25 (GPS-009)
Environmental Training	Section 30

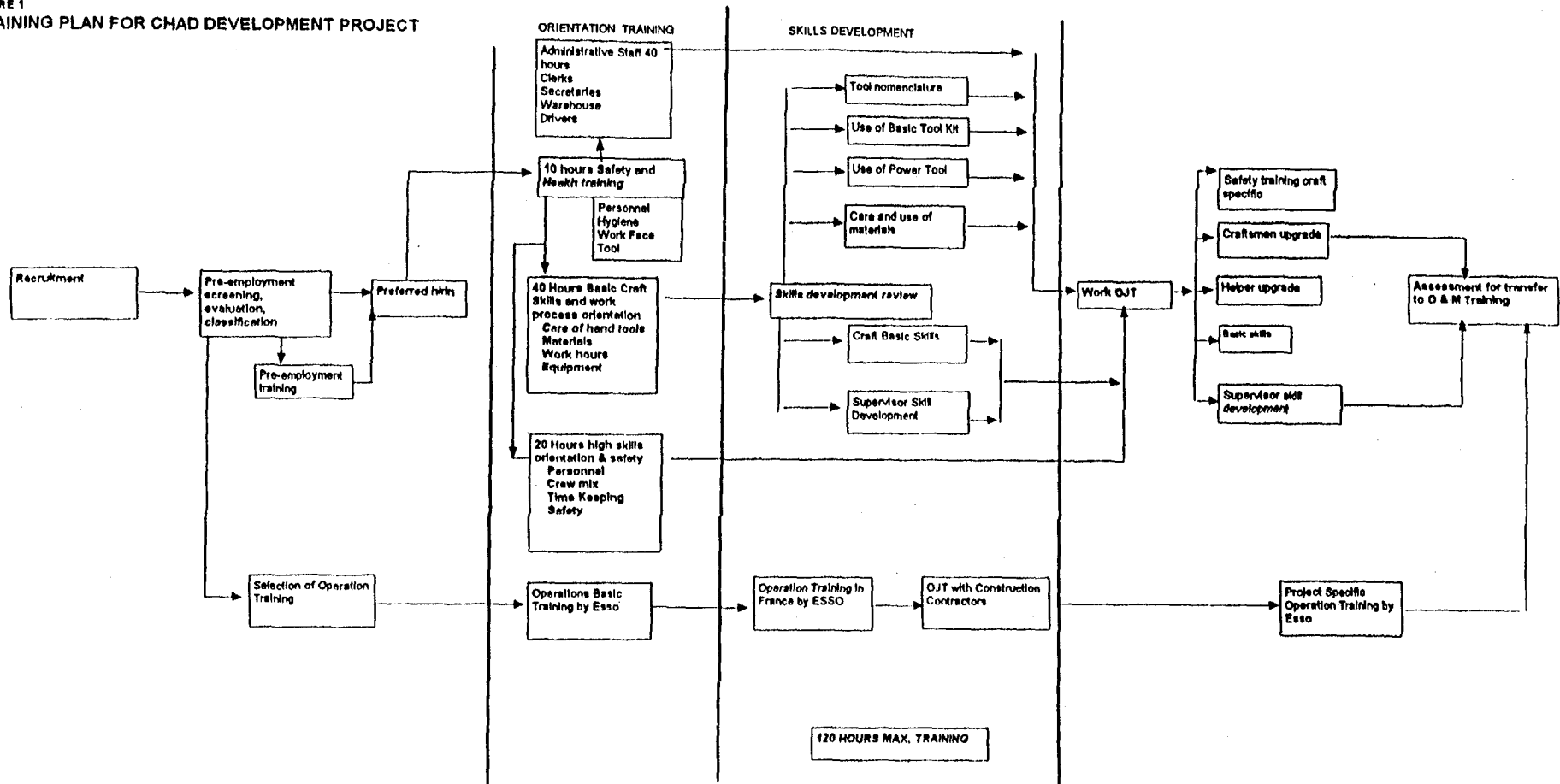
5.0 Other Training

- 5.1 Contractor, in cooperation with Esso, shall identify national/local hires to receive additional training for maintenance and operations. In an effort to develop the

necessary cadre of local talent to maintain and operate the pipeline after construction, Contractor or Esso may identify certain national/local workers who have demonstrated the ability and initiative to receive additional training as directed by Esso.

- 5.2 Contractor shall agree to release to Esso any national/local hire employee identified, and accepted by Esso, for additional training. The additional training will be provided by Esso. No additional compensation will be made to replace the released employee.

FIGURE 1
 TRAINING PLAN FOR CHAD DEVELOPMENT PROJECT



SOCIOECONOMIC INTERACTIONS

1.0 Scope

This section sets forth Esso's minimum requirements of Contractor for interactions with the populations in Chad and Cameroon, including Contractor's engagement and payment of staff and labor, provisions for care of staff and labor, and procurement of goods and services from local vendors/ businesses.

2.0 Definitions

For purposes of this Section 29, the following definitions will apply:

Expatriate	Citizen of a country other than the country in which the Work is being performed.
Local	Permanent resident of the project area (less than one hour commute to the Work Site)
National	Person who is a citizen or permanent resident of the country in which the Work is being performed.

3.0 General

- 3.1 Contractor's socioeconomic policies shall be consistent with Esso's Socioeconomic Action Plan, GPS-012, included in this Job Specification.
- 3.2 Contractor shall make every reasonable effort to consult with responsible authorities to avoid or mitigate potential conflicts over cultural or religious issues.
- 3.3 Contractor shall prepare and present to Esso, for review and approval, a Socioeconomic Action Plan. This Plan, further described in Paragraph 7.0, shall be based on Contractor's draft Socioeconomic Action Plan submitted with its bid and shall be updated within six (6) months after the date of Contract or three (3) months prior to in-country mobilization, whichever is sooner.
- 3.4 After initial submittal, all plans relating to this section of this Coordination Procedure shall be revised and resubmitted, as necessary, in order to obtain Esso approval prior to in-country mobilization.

4.0 Contractor's Organization and Assignments

- 4.1 Contractor shall identify its Socioeconomic Supervisor and provide a detailed description of assigned duties (coordinating all socioeconomic interactions) to Esso with Contractor's overall organization required by Paragraph 2.2 of Section 1 of this Coordination Procedure.

- 4.2 Contractor shall employ Business and Employment Coordinator(s) to work together with Esso's Business and Employment Coordinator(s) to accomplish the tasks outlined in GPS-012 and further defined in Contractor's Socioeconomic Action Plan. The Business and Employment Coordinator(s) shall be fluent in French.
- 4.3 A reasonable proportion of Contractor's superintendence staff shall have a working knowledge of French in order to communicate with the National work force. Contractor shall have available at Work Site at all times, a sufficient number of competent interpreters to ensure proper communication of instructions and information (in English, French, Arabic, and Local languages, as appropriate).

5.0 Contractor's Duties

Contractor's duties with respect to Socioeconomic Interactions include the following:

General

- 5.1 Developing, publishing, implementing and enforcing project standards, as defined herein and in Esso's Socioeconomic Action Plan, GPS-012, included in this Job Specification, for socioeconomic interactions between Contractor, its employees, and the general populations in Chad and/or Cameroon.
- 5.2 Utilizing local businesses for goods and services, provided they meet quality, and reliability requirements on a competitive basis.
- 5.3 Ensuring that water wells used by the local population are not impacted by project water supply wells by drilling deeper and/or screening a lower water-bearing layer than that used by the local population. If water supplies are adversely affected, Contractor shall provide an alternate potable water supply to users of impacted wells.
- 5.4 Reporting conditions to Esso that may lead to strained relations with Local populations and working with Esso to mitigate effects from these situations.
- 5.5 Following guidelines in Esso's Socioeconomic Action Plan, GPS-012 in this Job Specification, for hiring of Local and National employees. The objective of these guidelines is to provide National and Local labor with employment opportunities in a manner that distributes the economic benefits of the Work equitably between Local villages. This could involve hiring a cross-section of employees from the towns or villages near the Work Site and keeping these employees for the entire Work in their country.
- 5.6 Providing orientation training for all employees covering health, safety, environmental awareness, and fire response procedures as per Section 27 of the Coordination Procedure.

- 5.7 Providing basic skill and skill development training for Local and National employees, per Section 27 of this Coordination Procedure, to prepare them to meet the requirements of their assigned jobs.
- 5.8 Consulting with Esso on relevant regulations and inspections required by governmental authorities (e.g., labor law, visas, overtime, etc.).
- 5.9 Recognizing the importance of religious and other customs in all dealings with its staff and labor.
- 5.10 Taking all reasonable precautions to prevent any unlawful or disorderly conduct by or amongst its staff and labor. Contractor shall provide protection of persons and property in association with the Work Site and against the same.
- 5.11 If sites of archaeological value are discovered during construction, Contractor shall leave the archaeological findings undisturbed and shall immediately report the event to Esso. Esso will instruct the Contractor how to proceed with the Work.

Engagement and Payment of Staff and Labor

- 5.12 Making arrangements for the engagement of all labor, Local or otherwise, and providing transportation, housing, feeding and payment thereof. To the extent practicable and reasonable, employing staff and labor with the required qualifications and experience from sources within the country where the Work is being performed (Chad or Cameroon respectively). As far as practicable all labor, both skilled and unskilled, shall be residents of the region in which the Work Site is situated.
- 5.13 Contractor shall not recruit or attempt to recruit its staff and labor from amongst persons in the service of Esso or any of Esso's Contractors on the Project.
- 5.14 Contractor shall pay rates of wages and observe conditions of labor as specified Clause 2.1.12 of the Principal Document.
- 5.15 Preparing an Employment Plan that describes its proposed method of employee payment. The plan submitted with Contractor's bid, shall be updated and resubmitted with Contractor's Socioeconomic Action Plan. Elements of this plan are outlined in Paragraph 7.0.

Provisions for Care of Staff and Labor

- 5.16 Contractor's principal duties with respect to industrial hygiene, health, sanitation and medical facilities and services are described in Section 23 of this Coordination Procedure. Additional Contractor safety and health care duties are described in Section 22 of this Coordination Procedure.

- 5.17 Unless stated otherwise herein, Contractor shall provide and maintain such accommodations and amenities as it considers necessary for all its staff and labor, employed for the purposes of or in connection with the Contract.
- 5.18 Contractor shall arrange for the provision of a sufficient supply of suitable food for all its staff, labor and Subcontractors, for the purposes of or in connection with the Contract. If sources of adequate quality and quantity can be reasonably secured, Contractor shall purchase beef, poultry, fruits, vegetables, etc. from Local/National vendors. In order to prevent hunting of wild game in support of project food needs, wild game will not be served/consumed at project camps.
- 5.19 In cases where Contractor's camp moves during a work season, Contractor shall house non-Local labor at its camp(s) and have the option of housing Local labor. In cases where Contractor's camp does not move during the work season, Contractor may choose to house workers in its camp(s) or shall work with the community, local entrepreneurs and Esso to ensure that adequate housing and facilities are available in the local community to accommodate workers without displacing or adversely affecting the existing population or environment, or overloading existing infrastructure.
- 5.20 Contractor shall provide, or make available, transportation to and from the Work Site to workers living away from the Work Site. Pick-up and return shall be at central points in multiple villages as necessary.
- 5.21 Within two weeks of cessation of temporary camp site usage, unless otherwise required by Contractor or agreed with Esso, the temporary camps/housing provided by Contractor shall be removed and the site restored, all to the approval of Esso. Water wells shall be plugged when abandoned unless Esso specifically requests that they be left functional.
- 5.22 Contractor shall be responsible for the return to the place where they were recruited or to their domicile of all persons employed for the purposes of or in connection with the Contract. Contractor shall also maintain such persons as are to be so returned in a suitable manner until they shall have left the Work Site or have left Chad and Cameroon in the case of persons who are not Nationals and have been recruited from outside Chad and Cameroon.
- 5.23 Contractor shall make all necessary arrangements for the transport, to any place as required for burial, of any of its Expatriate employees who may die in Chad or Cameroon or while in transit to or from Chad or Cameroon to perform the Work. Contractor shall also be responsible, to the extent required by the local and national regulations and customs, for making any arrangements with regard to burial of any of its Local or National employees who may die while engaged in the Work.

6.0 Esso's Duties

- 6.1 Provide Contractor with a framework to hire Locals and Nationals in an equitable manner as per Esso's Socioeconomic Action Plan, GPS-012.
- 6.2 Consult with village and government officials to identify Work Site areas that may be sensitive for religious, cultural or other reasons. Identify appropriate actions to mitigate Local concerns, and notify Contractor of any related actions required by it.
- 6.3 Provide a Business and Employment Coordinator to interface with Contractor and the Local/National population regarding employment, business opportunities and other socioeconomic issues.

7.0 Contractor's Socioeconomic Action Plan

Prior to Contractor beginning in-country construction activities, it shall provide an overall Socioeconomic Action Plan Pursuant to paragraph 3.0 that details how Contractor will meet the provisions of paragraph 5.0. This plan shall include , at a minimum, the following sections:

7.1 Public Awareness

Contractor shall develop a Public Awareness Plan that details how the Contractor will perform the following tasks:

- Assist Esso with general consultation and public awareness plans.
- Prepare public awareness material and presentations that define labor needs for local/national presentations.
- Interact with Esso's Business and Employment Coordinator(s).
- Be aware of and respond to changes in public attitude that might require additional public awareness action(s).

7.2 Employment

Contractor shall develop an Employment Plan that details how the Contractor will perform the following tasks:

- Utilize Local/National labor.
- Estimate the number and type of positions to be filled by Locals/Nationals and expatriates.
- Feed, house and transport Local/National labor.
- Hire, pay and return home at the end of the project or at termination Local/National labor.

7.3 Business Opportunities

Contractor shall develop a Business Opportunities Plan that details how the Contractor will perform the following tasks:

- Estimate and communicate the number and type of services and goods to be provided by Local/National subcontractors and the corresponding estimated revenues/value of these business opportunities.
- Utilize local/national subcontractors/vendors for services and goods.
- Identify, hire and pay Local/National subcontractors.

7.4 Land Use

Contractor shall develop a Land Use Plan that details how the Contractor will perform the following tasks:

- Establish sites for construction activities.
- Maintain sites in accordance with Job Specification.
- Comply with all applicable government statutes and regulations.
- Complete reinstatement of work to the satisfaction of Esso, and initialize damage claims to Esso's satisfaction.

7.5 Procedures

In addition to the Socioeconomic Action Plan elements discussed above, Contractor shall provide procedures that define:

- Actions and processes that will be used to achieve Socioeconomic Action Plan objectives.
- Socioeconomic action approval process and scheduled dates for deliverables.
- Mechanism for monitoring, enforcing, and modifying the Socioeconomic Action Plan, including responsibilities of contractor auditors and proposed methods for interacting with Esso representatives.
- Process for resolving conflicts between socioeconomic and construction related issues.
- Procedure for managing the change of socioeconomic personnel, goals, schedules, deliverables, or procedures.
- Method for obtaining Esso approval for changes in the Socioeconomic Action Plan goals, schedule, deliverables, or procedures.
- Procedure for incorporating change (improvements) to the Socioeconomic Action Plan.

8.0 Procedural Requirements

- 8.1 Contractor shall keep proper records of the time worked by every employee engaged in the Work, the class of work on which employed, the wages paid and the training received. Records shall also reflect the numbers and types of positions held by Locals and Nationals.

Such records shall be available for review at any time by Esso or any duly authorized government representative, and monthly labor reports summarizing this information will be submitted to Esso. Contractor shall produce, if required, such other records as may be necessary as evidence of its compliance with the requirements of Chadian or Cameroonian labor/employment laws, as well as Esso's Socioeconomic Action Plan, GPS-012.

- 8.2 Contractor shall submit quarterly summaries of the Local/National goods and services purchased/utilized and the rationale for selection of all subcontractors/suppliers.
- 8.3 Contractor shall provide by 1 October of each year, an annual forecast of goods and service needs which could be filled by Local/National entrepreneurs and businesses in the following calendar year.
- 8.4 Contractor shall provide monthly reports to verify compliance with Esso's Socioeconomic Action Plan(s) and government regulations as per Section 21 of this Coordination Procedure.

ENVIRONMENTAL MANAGEMENT

1.0 Scope

This section sets forth Esso's minimum requirements of Contractor for implementing an environmental management program to protect the Work Site and surrounding areas from unacceptable impacts. This program shall include Contractor's waste management facilities and services; soil preservation and site restoration practices, protection of plant and animal species; air, noise, and water pollution prevention measures; and environmental monitoring program.

2.0 Definitions

For the purposes of this Section 30, the definitions in Section 29 of this Coordination Procedure as well as the following definition will apply:

Hazardous Material Reactive, flammable, radioactive, corrosive or toxic material posing risk of harm to those exposed to it. Hazardous materials most likely to be used in project areas include explosives, fuels (gasoline, diesel), lubricants, solvents, chemicals for developing radiographs and sources of radiation.

3.0 General

- 3.1 A key factor in environmental protection is that each organization and its employees must be committed to implementing and adhering to programs that will protect environmental resources. Contractor shall develop an environmental management plan which outlines its objectives, implementation strategies to meet those objectives, and how compliance with this plan will be monitored and enforced.
- 3.2 Contractor shall ensure that its operations and any facilities built (or equipment installed) for Esso's use are in compliance with all applicable environmental regulations as well as Esso project environmental standards, specifications and procedures in this Job Specification.
- 3.3 In order to prevent the generation of unnecessary hazardous wastes, certain chemicals and substances shall not be used on the project. These substances are listed in Table 30-1. If Contractor feels that reasonable alternatives do not exist for certain applications, Contractor may contact Esso and petition for a deviation from this requirement of the Job Specification.

- 3.4 Contractor must satisfy project environmental standards with respect to site clean-up, restoration and reclamation and receive Esso's written acceptance of compliance before it can abandon a site.
- 3.5 With the exception of Contractor's soil erosion mitigation plan (described in Paragraph 9.0, below) for which a draft is required with the Contractor's bid, all plans and procedures relating to this section of this Coordination Procedure are to be submitted to Esso for approval within six (6) months of date of Contract award or three (3) months prior to in-country mobilization, whichever is sooner.
- 3.6 After initial submittal, all plans relating to this section of this Coordination Procedure shall be revised and resubmitted, as necessary, in order to obtain Esso approval prior to in-country mobilization.

4.0 Contractor's Organization

- 4.1 Contractor shall appoint an environmental manager, environmental supervisor(s) and field environmental monitor(s) and provide a detailed description of their assigned duties and responsibilities to Esso with Contractor's overall project organization required by Paragraph 2.2 of Section 1 of this Coordination Procedure. Qualifications and required training for environmental staff shall also be provided for Esso review and approval.
- 4.2 Contractor's environmental organization shall have lines of authority that avoid conflict of interest with its construction/operations organization.

5.0 Contractor's Duties

Contractor's principal duties with respect to environmental management shall include:

5.1 Permits

- 5.1.1 Consulting with Esso on environmental regulations and inspections required by governmental authorities. Contractor shall comply with all requirements and obtain any permits that may be necessary.
- 5.1.2 Obtaining all necessary licenses and permits prior to start of Work. Regular liaison with government field representatives will be the responsibility of an assigned Esso representative. All conditions of agreements between the governments and Esso, and conditions of permits shall be met by Contractor. Inconsistencies between conditions of different permits will be rectified prior to start of Work.

5.2 Publication, Monitoring and Enforcement of Rules and Standards

- 5.2.1 Detecting, reporting and removing unhealthy or environmentally unsound conditions.
- 5.2.2 Developing, publishing (in English and French) and enforcing project environmental standards for the Work Site.
- 5.2.3 Preparing, maintaining and implementing a plan for providing the required environmental protection measures as specified in this Section 30 of the Coordination Procedure and Specifications CCS 21-20-107, CCS 21-20-108 and GPS-011.
- 5.2.4 Implementing a monitoring program for the Work. Employing qualified and trained environmental monitors for monitoring and reporting Contractor's compliance with the environmental management standards and for documenting site conditions before Contractor begins Work in a given area (e.g. type of environment, evidence of human impacts or natural soil erosion, water quality).

5.3 Worker Education

- 5.3.1 Providing all workers with a resource conservation/protection briefing (in English or French, as appropriate) before they begin work (while being inducted into the on-site work force). The briefing shall contain information on sensitive and protected biological resources in the Work area, mitigation measures and environmental management prescriptions to be implemented, the importance of mitigation compliance, and any environmental hazards in the Work area.
- 5.3.2 Conducting monthly formal training programs (the duration of which shall depend on the number of topics requiring review) for the work force (in English or French, as appropriate) to discuss environmental hazards and environmental protection measures for the Work area and review Contractor's environmental mitigation program requirements.

5.4 Management of Chemicals and Wastes

Complying with relevant Government regulations and Esso guidelines regarding safe handling, storage and transport of toxic materials and hazardous chemicals (reference Section 22 of this Coordination Procedure). Although local or regional regulations may take precedence, as a minimum Esso's project environmental standards shall be applied (reference this Section 30 and related specifications in this Job Specification).

5.4.1 General Waste Management

- 5.4.1.1 Developing and implementing a waste management program that is consistent with Esso's environmental standards and addresses the items below. Minimum requirements are provided in the Waste Management Requirements, GPS-011.
- 5.4.1.2 Providing domestic waste water collection and treatment systems for the Work camps. Minimum standards for collection and treatment systems are included in the Packaged Sewage Treatment System Specification, GPS-004.
- 5.4.1.3 Managing and disposing (and segregating) its wastes, and delivering its non-recyclable hazardous wastes (e.g., batteries) to Esso approved facilities for treatment/disposal (facilities will be located in the oil field area in Chad and at the pump station locations in Cameroon) in conformance with Esso's "Waste Management Guidelines". Hazardous wastes shall not be transported across country borders. Minimum standards for incinerators and for landfill construction and operation are provided in GPS-006 and GPS-007 in this Job Specification.
- 5.4.1.4 Providing sufficient covered garbage containers at appropriate locations to ensure adequate storage capacity and prevent litter from accumulating.
- 5.4.1.5 Collecting and disposing of garbage and refuse on a daily basis. To avoid attracting rodents and potential predators prior to final disposal, all food-related trash and litter (wrappers, cans, bottles, food scraps, etc.) shall be placed in closed containers having tight fitting lids.

5.4.2 Handling and Disposal of Hazardous Materials

- 5.4.2.1 Ensuring that refueling or refilling activities, storage and maintenance activities involving hazardous materials occur in previously disturbed areas whenever possible.

- 5.4.2.2 Ensuring that no maintenance, refueling or storage of hazardous materials occurs within 100 meters of a perennial or intermittent stream, riparian habitat or wetland unless this is unavoidable (e.g., with certain barge mounted operations, and trench dewatering pumps). Contractor's environmental manager shall approve areas to be used for storage, and handling activities involving hazardous materials.
 - 5.4.2.3 Storing all hazardous (reactive, flammable, radioactive, corrosive and toxic) materials in appropriate and clearly labeled (in English and French) containers or vessels. Storage shall be in lined storage areas large enough to contain the inventory in the event of a spill.
 - 5.4.2.4 Storing and handling all hazardous materials in a manner appropriate to their hazard characteristics and in accordance with Section 22 of this Coordination Procedure.
 - 5.4.2.5 Providing sufficient fire protection systems for storage facilities to control fires and/or the release of hazardous materials to the environment.
- 5.4.3 Spill Prevention and Response
- 5.4.3.1 Developing and implementing a spill prevention and response plan to minimize the likelihood and impacts of any spills and provide for disposal of contaminated soil and debris during the Work.
 - 5.4.3.2 Ensuring that all storage tanks and pumps are located within properly bermed areas with impervious liners to ensure that no fuel, oil, solvents, lubricants, chemical additives, or other potentially harmful substances can migrate into surface or ground water resources at any time.
 - 5.4.3.3 Ensuring that proper precautions are followed in the special cases where mobile equipment is required to operate and refuel within 100 meters of a water-body or wetland in order to minimize the risk of fuel spills into the water-body.
 - 5.4.3.4 Ensuring that fuel and service vehicles carry at least 10 kg of suitable commercial sorbent material for spill response so that spill containment and recovery operations can begin immediately after any release of hazardous liquids.

5.4.3.5 Providing adequate labor and supplies for all recovery and remediation of spill sites and for the proper disposal of related waste materials.

5.5 Protection of Plant and Animal Species and Habitat

5.5.1 Ensuring that Contractor's personnel do not engage in poaching; hunting; fishing; collection of vegetative material; keeping of pets; or purchase, possession, transportation, capture, sale or trade of wild plants or animals (or any parts or derivatives thereof) on the Work Site, associated right-of-way and camps, or surrounding areas.

5.5.2 Ensuring that Contractor's personnel do not engage in other prohibited activities including:

- keeping of domestic stock on the Work Site and associated areas,
- littering on the Work Site and associated areas,
- harassing or feeding wildlife in the Work Site and associated areas,
- unsanctioned recreational use of project vehicles throughout the Work Site and surrounding areas,
- possession of firearms or weapons while in the project area (except for security personnel).

5.5.3 Making it a condition of employment that expatriate employees, and all other employees housed by Contractor, comply with the restrictions above both on and off the Work Site. Monitoring project workers for compliance with these restrictions at the entrance to camps, in vehicles carrying workers and at Work Sites.

5.5.4 Working with Esso to identify trees/areas to be preserved as the Work area is defined and cleared, and protecting these from damage.

5.5.5 Inspecting all excavated trenches or other steep walled excavations, e.g. riverbank excavations, and removing any entrapped animals each morning and before backfilling.

5.5.6 Implementing suitable techniques and practices (including keeping soil disturbance to a minimum) to reduce creation of disease vector and invasive weed habitat. Using chemical or biological control as required and with the approval of Esso.

5.5.7 Cleaning newly-arrived equipment with appropriate cleansers to minimize the introduction of invasive or non-native agricultural pests or plant species.

- 5.5.7a Ensuring that, if construction proceeds from south to north, all equipment is thoroughly cleaned as it enters the southern end of the Mbere Rift Valley (290 km).
- 5.5.8 Disking areas where native invasive or weed species have begun to grow on the right-of-way, or other cleared project areas, before site reclamation. Disking shall occur before re-spreading the topsoil. If non-native species or particularly undesirable native weeds are growing in the area, then physical removal or application of herbicides to eliminate the weeds shall be performed by Contractor before site restoration begins.
- 5.5.9 Utilizing only existing upgradable access roads to the Work Site, whenever possible. Any new access roads shall be routed to avoid or minimize effects on sensitive environmental resources.
- 5.5.10 Controlling access along the Work Site right-of-way and on upgraded access roads to prevent access to and exploitation of previously undisturbed areas during construction. Erecting vehicle barriers where the Work Site crosses roads to prevent vehicular traffic from using the Work Site right-of-way. Guarding access roads at the barrier location when they are open for project-related traffic during the Work.
- 5.5.11 Reinstating natural barriers along the Work Site right-of-way when access is no longer needed especially near the limits of the core area of the Mbere Rift Valley (230-290 km).
- 5.5.12 Ensuring that the following special provisions are incorporated when the Work is near the core area of the Mbere Rift Valley (forested savanna at 230-290 km) or relatively undegraded portions of semideciduous forest (patches within 480-520 km and 570-675 km) and Atlantic littoral evergreen forest (patches between Kribi and Lolodorf):
- camps and storage facilities are located outside of these sensitive zones, except where approved by Esso,
 - workers are transported into and out of the construction areas each day,
 - worker movements and activities are restricted in these areas,
 - construction access is restricted to the right-of-way,
 - right-of-way width is minimized to the extent practical, and
 - all entry points to these sensitive zones are patrolled to prevent unauthorized access.

5.6 Air and Noise Pollution Mitigations

- 5.6.1 Ensuring that emissions from its equipment and facilities (including permanent facilities installed for Esso) meet the criteria provided in the Environmental Impact Mitigation Specification, CCS 21-20-108 in this Job Specification.
- 5.6.2 Ensuring that all equipment is in good condition, well maintained, and equipped with suitable mufflers to prevent excessive generation of air pollutants and noise.
- 5.6.3 Providing and implementing procedures for controlling noise levels near villages, townships, and urban areas.
- 5.6.4 Providing appropriate dust control measures, as approved by Esso, when required on a site for health, safety, or nuisance reasons.

5.7 Water Pollution Prevention

- 5.7.1 Ensuring that all water-body and wetland crossings comply with the standards in the Environmental Impact Mitigation Specification, CCS 21-20-108.
- 5.7.2 Ensuring that all liquid effluents (e.g., sewage treatment plant effluent, process/wash water, landfill leachate) meet the criteria provided in the Environmental Impact Mitigation Specification, CCS 21-20-108, at a minimum. Keeping testing records to justify that samples are within compliance. Recording surface water quality in locations likely to receive Work or camp related effluents or Work Site run-off (before discharge begins, monthly during the Work period, and after Contractor has prepared the site for closure or Acceptance by Esso).
- 5.7.3 Locating all staging areas, spoil storage areas, and other additional Work areas at least 15 meters away from the edge of water-bodies or wetlands, if topographic conditions permit. If topographic conditions do not permit a 15 meter setback, then these areas must be located at least 3 meters away from the water's edge. Only in the event of a direct crossing shall vegetation be cleared between these areas and a water-body or wetland.
- 5.7.4 Performing all concrete coating activities, at least 30 meters away from water-bodies or wells (unless designated by Esso).
- 5.7.5 Conducting clearing activities so that vegetation is cut off at ground level, leaving existing root systems intact, and removing the vegetation debris from the wetland or riparian area for disposal.

- 5.7.6 Only using herbicides or pesticides at least 30 meters away from a water-body or wetland.
- 5.7.7 Preventing flow of spoil off of the Work Site into water-bodies or wetlands.

5.8 Soil Preservation

- 5.8.1 Developing and implementing a program to minimize soil erosion on the Work Site which is consistent with the Soil Erosion Mitigation Specification, CCS 21-20-107 in this Job Specification.
- 5.8.2 Conducting clearing, grading, trenching, and backfilling operations as per all applicable specifications (e.g., environmental impact mitigation, soil erosion mitigation, and construction) in this Job Specification.
- 5.8.3 Salvaging surface material (topsoil) from Work areas and implementing soil erosion control measures as required in the Soil Erosion Mitigation Specification, CCS 21-20-107.
- 5.8.4 Inspecting soil erosion mitigation measures after rains and repairing them, as necessary, to ensure that the mitigation measures continue to prevent erosion during subsequent rain events. The integrity of the soil erosion mitigation shall be sufficient to provide continued protection against erosion until the site soils have stabilized and added protection is no longer necessary.
- 5.8.5 Selecting the site least likely to be adversely impacted by the Work, whenever reasonable, when siting borrow pits/areas. Locating borrow pits/areas away from flowing water. Locations must be reviewed by Esso.
- 5.8.6 Coordinating with Esso the use of latterite available at abandoned Esso sites (drilling pads, air strips, latterite pits, etc.), before creating new latterite pits for the Work.

5.9 Site Restoration

- 5.9.1 Performing a final site clean-up including removal of all litter, barrels, cans, drums, accidental spills and any other Work refuse or excess materials still on the Work Site after the Work has been completed, and before the facility is accepted by Esso. No shrub material or other plant cover shall be disturbed during this process.

5.9.2 Performing surface restoration and stabilization as per the Environmental Impact Mitigation Specification, CCS 21-20-108 in this Job Specification.

5.9.3 Using any excess topsoil as fill and cover for reinstating borrow pits/areas, landfill cover, or additional topsoil depth for site restoration after resspreading topsoil at a depth of 150 millimeters over areas to be revegetated.

6.0 Contractor's Environmental Management Plan

6.1 Contractor's environmental management plan shall be submitted to Esso for approval within six (6) months after the date of Contract or three (3) months prior to in-country mobilization, whichever is sooner. Contractor's environmental management plan shall explain how Esso's environmental objectives, outlined herein, will be achieved during Contractor's operations.

6.2 The environmental management plan shall describe how Contractor proposes to discharge the duties set forth in Paragraph 5.0 above, and shall contain as subsets or attachments Contractor's detailed waste management plan, spill response plan, and soil erosion mitigation plan (which are defined in more detail below). The environmental management plan's elements shall include:

6.2.1 A description of Contractor's organization as defined in Paragraph 4.0 above,

6.2.2 Discussion of the environmentally related responsibilities of each position and how each position will interact with the others to ensure that the designs comply with the environmental standards and expectations, designs are followed during the Work, inspections are made, results and approvals documented, remedial actions taken as necessary, and results reported to Esso,

6.2.3 Qualifications and training that will be required for various job positions (managers, supervisors, monitors, laborers, etc.), including environmental awareness training that will be provided for all workers,

6.2.4 A summary of environmental standards for the Work Site, including as a minimum the topics of :

- Environmental monitoring and assessment (baseline and ongoing)
- Soil preservation and erosion mitigations
- Protection of plant and animal species and habitats
- Site restoration
- Waste management
- Spill response

- Air and noise pollution
 - Work site controls (access, etc.)
- 6.2.5 The actions and processes that will be used to achieve the environmental standards and identification of responsible parties for each,
- 6.2.6 Discussion of the approval process and milestones for deliverables during each phase of the project (detailed design and engineering, construction, operation, etc.) as applicable,
- 6.2.7 A mechanism for monitoring and enforcing compliance with the plan, including responsibilities of Contractor auditors, interaction with Esso, implementation of remedial actions to resolve deficiencies, and documentation of management approval of remedial actions,
- 6.2.8 A process for resolving conflicts between the objectives of environmental and construction personnel,
- 6.2.9 Reports on environmental performance that will be provided to Esso,
- 6.2.10 Mechanism for obtaining approval from Esso for deviations from the project environmental specifications and for changing procedures/designs as necessary,
- 6.2.11 Procedures for managing change of personnel/organizations responsible for a task,
- 6.2.12 Provisions for incorporating improvements to the environmental management system.

7.0 Contractor's Waste Management Plan

- 7.1 Contractor's waste management plan shall be submitted to Esso for approval within six (6) months after date of Contract or three (3) months prior to in-country mobilization, whichever is sooner. This waste management plan shall meet or exceed the minimum requirements for waste treatment and disposal as described in the Waste Management Requirements, GPS-011, and shall contain the following information:
- 7.1.1 A table detailing the various types of waste to be generated, projected quantity and month when they will be generated, and the preferred and alternative treatment and disposal methods for each waste (see Table 30-2 as an example);
- 7.1.2 Safety/handling requirements for various wastes as applicable;
- 7.1.3 Methods of stabilizing wastes and preparing them for transport and shipment from generation sites to disposal sites, when necessary;

- 7.1.4 Methods to be used to transport the wastes, if necessary;
 - 7.1.5 Steps to be taken to minimize the amount of waste generated, and recycling options that will be pursued to reduce the amount of waste requiring disposal;
 - 7.1.6 A system to track the amount of each waste type generated, how it was managed and its final destination (Table 30-3 shows a sample data entry form). Contractor's operating waste disposal sites must maintain a computer database with records of all wastes received at the site and final destinations within the facility (e.g. which landfill cell). Contractor's plan shall include information on its proposed software package and forms for this database;
 - 7.1.7 The location and detailed engineering specifications for all waste management facilities to be used;
 - 7.1.8 A monitoring system to record oily, hazardous, and high volume waste compositions; landfill leachate quality; landfill monitoring well water quality; water treatment effluent quality; etc. monthly, or more often as specified elsewhere in this Job Specification;
 - 7.1.9 The construction, operation, and closure standards and practices that will be used for waste facilities (landfill, burial pits, incinerator, sewage treatment unit, etc.) as well as Contractor's plans for spill prevention, spill containment and treatment at waste management sites; and
 - 7.1.10 A plan for the transition of permanent facilities from Contractor to Esso operation.
- 7.2 If Contractor will be operating in multiple locations, its waste management plans should include any site specific modifications to the overall plan that will be necessary for each location.

8.0 Contractor's Spill Response Plan

Contractor's spill response plan shall be submitted to Esso for approval within six (6) months after the date of Contract or three (3) months prior to in-country mobilization, whichever is sooner. This spill response plan shall contain the information described in Attachment 30-1.

9.0 Contractor's Soil Erosion Mitigation Plan

9.1 Contractor's soil erosion mitigation plan shall be based on Contractor's draft soil erosion mitigation plan submitted with its proposal and shall be updated within six

(6) months after the date of Contract or three (3) months prior to in-country mobilization, whichever is sooner. This soil erosion mitigation plan will be used to manage impacts from Contractor's activities. Contractor's soil erosion mitigation practices shall be consistent with Esso's minimum required practices as described in the Soil Erosion Mitigation Specification, CCS 21-20-107. Site specific portions of the plan will be developed so that mitigations appropriate for the conditions at each Work Site are included. The plan shall be revised until approved by Esso as per Sub-paragraph 3.6, above.

9.2 Contractor shall propose a procedure to vary specific mitigations, as appropriate, based upon site conditions encountered during Work. Changes shall require Esso approval.

9.3 Contractor's Soil Erosion Mitigation Plan shall contain a minimum of the following:

9.3.1 Discussion of each erosion control measure required in detail. The discussion shall include: map symbol, reference detailed sketches, when and where to use the control measure and where not to use the control measure.

9.3.2 A summary legend of symbols representing each measure required

9.3.3 An estimate of the quantities of each measure to be used

9.3.4 Preliminary indication, on alignment sheets, of where (and what type) environmental control measures will be utilized

9.3.5 A typical weekly report form for reporting status

9.3.6 A typical monthly report form for reporting environmental mitigation actions, and integration of those measures into "as built" drawings/alignment sheets.

10.0 Procedural Requirements

10.1 Contractor shall keep all records from environmental inspection, monitoring/testing, and auditing activities for three (3) years after Acceptance, and make all documentation available for review at the request of Esso.

10.2 Contractor shall conduct regular inspections of its facilities to ensure that environmental protection measures are being implemented consistent with the requirements of Esso and all applicable regulations and permits. Written reports documenting the results of daily monitoring activities shall be submitted to Esso weekly.

10.3 Contractor shall immediately investigate all potentially serious environmental infractions that occur, and take actions to prevent them from recurring, if

necessary. Results of investigations will be given to Esso within a month of completion.

- 10.4 Contractor shall require every employee, after environmental training, to sign a letter (in appropriate language and/or explained in appropriate language until understood) stating that non-compliance with Esso's environmental policies, described in this Section 30 and the Environmental Impact Mitigation Specification, CCS 21-20-108, will be grounds for immediate dismissal.
- 10.5 Contractor shall cooperate with and assist Esso environmental representatives conducting inspections and audits of Contractor's environmental performance, monitoring, and reporting. Corrective and preventive actions recommended by Esso will be discussed and implemented as necessary to ensure Contractor fulfills the scope and intent of the Contract.

Table 30-1

Chemicals and Substances Not to be Used

Substance to Avoid	Reason for Restriction	Alternatives
Polychlorinated Biphenyls(PCBs)	Human carcinogen, bioaccumulative.	Silicones, esters, cast resin.
Friable asbestos	Inhalation of fibers causes lung damage. Regarded by World Bank as hazardous substance, use to be avoided.	Alternatives are readily available for insulation and roofing uses. There are no clearly superior alternatives for some uses such as brake pads for trucks.
Pentachlorophenol (PCP) and formaldehyde (biocides)	Human carcinogens, eco-toxins. May meet World Bank definition of hazardous waste when discarded.	Glutaraldehyde, isothiazolin (or other low toxicity biocide).
Chlorofluorocarbons(CFCs)	Implicated in stratospheric ozone depletion. Over 125 nations, including US, have agreed to virtual phase-out of CFC production by 1996	Depends on use. USEPA has published lists of USEPA-accepted alternatives for various uses [1, 2].
Leaded paints	Toxic at relatively low levels, bioaccumulative. May meet World Bank definition of hazardous waste when discarded.	Unleaded paints. Also, water based or low volatility solvent formulations can reduce potential health effects of oil based paints.
Chlorinated solvents (e.g., carbon tetrachloride, trichloroethylene).	May have toxic effects (vary depending on the compounds).	Non-chlorinated hydrocarbon-based solvents, steam cleaning.
Heavy metals (reverse emulsion breakers)	Various adverse effects. May meet World Bank definition of hazardous waste when discarded.	Polymer (non-latex) based formulations.
Mercury (in pressure-measuring devices/instrumentation)	Neurotoxic effects. May meet World Bank definition of hazardous waste when discarded.	Differential pressure cells/transmitters, pneumatic or electric instrumentation.
Lead naphthenate (lubricant)	Neurotoxic effects. May meet World Bank definition of hazardous waste when discarded.	Lead-free lubricants.
Leaded thread compound	Toxic at relatively low levels, bioaccumulative. May meet World Bank definition of hazardous waste when discarded.	Lead-free thread compounds such as Bestolife 2000 (for tubing and casing).
Chromate corrosion inhibitors	Hexavalent form of chromium is toxic to humans and many animals.	Sulfite or organic phosphate corrosion inhibitors, especially those with reduced toxicity amine function.
Chrome lignosulfonate (as fluid loss controlling agent) - all right in small amounts for rheology control	Hexavalent form of chromium is toxic to humans and many animals	Carboxymethyl starches for fluid loss control. Improved mud control to minimize fluid loss. If used (for rheology), keep dose small and use formulations with trivalent form complexed in lignin structure.

REFERENCES FOR TABLE 30-1

1. United States Federal Register, Volume 59, No. 53, (59 FR 13044), Office of the Federal Register, National Archives and Records Administration, Washington, D. C., March 18, 1994.
2. U. S. Environmental Protection Agency, "Acceptable Substitute Refrigerants Under SNAP," EPA-430-F-94-014, April, 1994.

Table 30-2

Sample Table for Projected Waste Types, Amounts, Schedule, and Management Options

Waste Type	Quantity (Units)	Waste Generation Schedule (check months that waste stream will be generated)												Preferred Management Method	Alternative Management Method	
	Total:		J	F	M	A	M	J	J	A	S	O	N	D		
		'97														
	Per Month:		J	F	M	A	M	J	J	A	S	O	N	D		
		'98														
	Total:		J	F	M	A	M	J	J	A	S	O	N	D		
		'97														
	Per Month:		J	F	M	A	M	J	J	A	S	O	N	D		
		'98														
	Total:		J	F	M	A	M	J	J	A	S	O	N	D		
		'97														
	Per Month:		J	F	M	A	M	J	J	A	S	O	N	D		
		'98														
	Total:		J	F	M	A	M	J	J	A	S	O	N	D		
		'97														
	Per Month:		J	F	M	A	M	J	J	A	S	O	N	D		
		'98														

Table 30-3

CDP WASTE INVENTORY/TRACKING FORM

Send to: _____
 Database Recorder

Submitted by: _____ Date Waste Generated: _____

Field: _____ Date Waste Disposed: _____

Facility: _____ Volume: _____ Density: _____

Waste Type (Check One)

Barrels, Drums, and Cans (empty)

Cement and Concrete Wastes (Including Cement-Contaminated Soil)

Construction Debris

Contaminated Soil (Oil)

Domestic Wastes

Filter Hay

Fuel Oil Filter Sludge

Hydrotest Fluid

Incinerator Ash

Lead Acid Batteries

NiCad Batteries

Paint and Coating Wastes

Pigging Wastes

Sludge's, Slop Oil and Tank Bottoms

Unused, Spent, Expired, and Waste Chemicals and Additives

Used Lube Oil Wastes

Used Tires

Vegetation Debris

Water Treatment Sludge

Other: _____

Disposal/Treatment Method (check all that apply)

Above-Ground Contained Storage

Pit Storage

Land Application Site

Land Treatment Site

Composting Facility

Incinerator

Burn Site

Pit Burial Site

Landfill (Including Trench and Burial Method)

Water Treatment Facility

In Situ Spill Treatment

Disposal Facility

Site Name: _____

Site Location: _____

City/Province: _____

Country/Post Code: _____

Check One:

On site (Contractor's) Facility

Esso Facility

Third-party Disposal

Third-party recycle/reclaim

Hauler

Company: _____

Driver: _____

License No: _____

Received by: _____

Disposal Facility: _____

Date: _____

On site Destination: _____

Disposal Facility to acknowledge receipt of materials to originator

Attachment 30-1

SPILL RESPONSE PLAN REQUIREMENTS FOR THE WORK PERIOD

1.0 Background and Definitions

Consistent with Esso's worldwide oil spill response organization structure, a three tiered response organization structure will be used to respond to onshore and offshore spills of differing magnitude and significance. The smallest spills would be handled by a tier 1 response. Additional tiers would be activated as the response capabilities of each operational tier is exceeded.

Tier 1 response A tier 1 response would be considered after a small spill of hydrocarbons which is deemed to pose no significant threat to the environment. A tier 1 response can be handled with local resources, without recourse to outside support.

A typical example of a tier 1 response would be a local operating organization responding to a spill of limited volume that occurred at or near a facility as a consequence of routine operations. It is expected that all of Contractor's potential spills will be tier 1 spills.

Tier 2 response A tier 2 response would be considered after an operational spill of hydrocarbons of moderate magnitude which is deemed to pose a tangible threat to the environment. A tier 2 response has the potential to exhaust the local resources, and would include the mobilization of national and mutual aid resources.

Tier 3 response A tier 3 response would be implemented after a large or ongoing spill of hydrocarbons which is deemed to pose a significant threat to the environment. A tier 3 response has the potential to exhaust local and national resources, and includes the mobilization of international resources such as Oil Spill Response Limited (OSRL).

2.0 General

2.1 Spill response plans shall include prevention and response for spill scenarios likely during Contractor's operations such as a storage tank leak/failure, storage tank overflow during delivery, pipe rupture, transportation loading and unloading accidents, and refueling mishaps.

Attachment 30-1, continued

The spill response plans shall address spill prevention and response for all chemicals which may be of environmental concern that will be used, stored, or transported by Contractor in its operations (e.g., fuels, lubricants, solvents), and the amount and mode of storage in each area.

Contractor's spill response plan shall include the elements outlined below at a minimum:

- 2.1.1 *Introduction.* Defines scope of operations and summarizes response actions.
- 2.1.2 *Notification Procedures.* Defines procedures of notification to be used in the event of a spill. Parties to be notified will include Esso Management and response teams.
- 2.1.3 *Spill Response Organization.* Defines the structure for oil spill response organization, responsibilities and job descriptions, and the person(s) responsible for each job description.
- 2.1.4 *Spill Response Equipment.* Defines quantity and types of equipment required to be stockpiled at specific locations. This shall include requirements for each Work crew to have sufficient supplies of absorbent and barrier materials (suitable for use with the materials present) on-hand to allow the rapid containment and recovery of any spills.
- 2.1.5 *Spill Risk Assessment.* Defines potential most-credible and most-likely spills during Contractor's project related activities.
- 2.1.6 *Spill Prevention.* Defines activities, procedures, and equipment that will be used to prevent the occurrence of spills or, failing that, limit their impacts. This section shall describe the preventive and mitigative measures that shall be taken to:
 - avoid or minimize impacts of spills of fuel, lubricants, or hazardous materials, especially within any municipal watershed area or within 30 meters of any water-body or wetland,
 - require that all fueling and lubricating be done in areas designated for such purposes (with such areas to be located away from all wetlands and water-bodies), and
 - include procedures for collection and disposal of waste generated during vehicle maintenance.

Attachment 30-1, continued

- 2.1.7 *Spill Response Options.* Defines spill response options that would be used in the event of a spill. This would include guidance on spill source control and containment (actions and equipment that would be employed to minimize potential effects of spills by reducing the amount of material released once a spill occurs) as well as guidance on which response options may be more or less appropriate under certain circumstances. To the extent that certain facilities/areas are unique or pose unusual challenges, separate action plans shall be developed.
- 2.1.8 *Recovered Chemicals and Waste Disposal.* Defines methods that would be used to store, transport, and dispose of recovered chemicals and associated waste. Disposal options may include burial in landfills, bioremediation, incineration, etc. Contractor's plan shall include procedures (consistent with Contractor's waste management plan) regarding treatment, excavation and disposal of any soil materials contaminated by spillage (including materials out of wetlands or water-bodies).
- 2.1.9 *Health and Safety.* Defines procedures and equipment required for working personnel, and defines procedures and measures for evacuation of public if needed.
- 2.1.10 *Drill and Training.* Defines drill and training requirements for spill response personnel including frequency of drills/training, content of training, nature of drills, etc. Training will address personnel health and safety issues in addition to spill response operations.
- 2.1.11 *Reporting.* Defines the reporting procedures that will be followed to inform Esso of the nature of the spill, actions taken, future actions required, impacts of the spill on the environment, and the current status of the environment.
- 2.2 Spill response plans shall be task oriented and written in a manner which allows evaluation of their effectiveness in addressing all of the necessary topics.
- 2.3 Spill response plans shall be written to include contingency plans for dealing with all environments in which Contractor will conduct its operations (terrestrial, river, stream, wetland, marine). This will entail development of environment-specific procedures, which may be presented as separate sub-sections of plan sections such as spill prevention and spill response.

Attachment 30-1, continued

3.0 Contractor's Duties

- 3.1 Contractor shall notify Esso of all spills greater than forty (40) U.S. gallons (one hundred fifty (150) liters) or any spill into water within sixty (60) minutes of identification. Information provided will include the type of material spilled, location, time of spill, estimated amount of material spilled, a description of the area impacted (size, terrain, ecosystem type), threatened populations, endangered water resources, actions taken to contain the spill, current clean-up activities, and any other pertinent information.
- 3.2 Contractor shall provide sufficient equipment and manpower throughout the project area for tier 1 spill response in order to protect local resources and mitigate local damage. It is anticipated that all potential spills during Work operations would be tier 1 spills. Contractor shall design and operate its facilities and size tanks, containment areas, etc. so that this is true. If Contractor identifies spill scenarios (e.g., sensitive environments) where potential spills would not be tier 1, it should discuss these with Esso to establish a viable mitigation and/or response plan.
- 3.3 In the event of a tier 2 or tier 3 spill, Contractor shall respond to the best of its ability with tier 1 response equipment in order to stop the discharge and contain the spill while additional resources are being summoned. After an Esso team leader and additional response teams have arrived, Contractor shall continue to assist in the containment and clean-up operations.

4.0 Esso's Duties

Notify appropriate local and national government agencies of spills and the measures being taken to minimize impacts and restore the site.

5.0 Procedural Requirements

Contractor shall:

- 5.1 Report all tier 1 spills greater than forty (40) U.S. gallons (one hundred fifty (150) liters) and all spills into water to Esso within one (1) hour.
- 5.2 Report all tier 2 and tier 3 spills to Esso immediately after they have been classified as not within Contractor's tier 1 capabilities.
- 5.3 Keep records of the type, size, and location of all spills, the response and remedial actions taken, and the status of the sites and submit these to Esso once a week.

Attachment 30-1, continued

- 5.4 **Maintain records of the spill response training provided to each employee as well as the drills that have been conducted. Deficiencies shall be recorded and implementation status of corresponding improvements shall be documented.**

INTERFACE MANAGEMENT

1.0 Scope

This section sets forth Esso's minimum requirements for managing the interfaces between and among contractors engaged by Esso to execute the Work.

2.0 General

2.1 "Interface" as defined in this Section can be either an organizational interface or a technical interface.

- Organizational interfaces occur when two or more organizations meet and need to describe who does what, how it is done and the communication flows;
- Technical interfaces are either 1) a physical interface typically defining how two areas must fit together (e.g. pipeline/pump station tie-in point); 2) a system interface which is a system that goes through several areas (e.g. emergency shutdown system); 3) an information interface which is information exchanged between two organizations for design or other work (e.g. finished grade elevations) or 4) a shared service wherein for example, during construction multiple contractors at a location may require a service such as catering, transportation, communications or utilities. Technical interfaces are commonly communicated using deliverables such as drawings, specifications and equipment datasheets.

2.2 Interfaces may be required between the following organizations, including their subcontractors, for execution of the Work. Any other contractor interfaces identified during the Project and required for the execution of the Work shall also be managed according to this Procedure.

Field Facilities Contractor
Floating Storage and Offloading (FSO) Facility Contractor
Logistics Contractor(if applicable)
Offshore Pipeline Contractor
Onshore Pipeline Installation Contractor
Pump Stations Contractor
Road Upgrading Contractor
Telecommunications Contractor
Chad Project Management Team

2.3 Table 1, Interface Management Matrix describes where an interface is anticipated between contracts and which contractor will be the "Lead Contractor"

for that interface. The Lead Contractor is responsible for developing and administering the Interface Management Plan.

- 2.4 It is the philosophy of the Project, that to the extent possible, the interfaces between contractors be handled directly between themselves.

3.0 Contractor's Organization

Contractor shall identify a member of its team who shall have primary responsibility for interface management and shall be the contact for other contractors and for Esso regarding interface management issues. Said team member or designated representative shall be empowered by Contractor to make decisions and shall be readily available to meet with other contractors or Esso at the Project's various Work Sites.

4.0 Contractor's Duties

The principal duties for all contractors with respect to interface management on the Work includes:

- 4.1 Identifying interfaces with other contractors and providing a list of interfaces and schedule requirements to Lead Contractor within forty five (45) calendar days after date of Contract for incorporation into the Interface Management Plan per Section 5.0 of this procedure,
- 4.2 Incorporating interface coordination into work execution plans and recognizing time requirements for interfaces in schedules,
- 4.3 Participating in interface coordination meetings,
- 4.4 Reviewing, approving and complying with the Interface Management Plan,
- 4.5 Resolving interface problems,
- 4.6 Assuring interface issues do not result in changes to the scope, execution schedule or contractual obligations. Impacts or issues in conflict with these requirements must be approved by Esso in accordance with Article 7-Changes of the Principal Document,
- 4.7 Coordinating the participation of subcontractors, as required, in interface activities to execute the Work.

Additionally, the principal duties of the Lead Contractor in an interface relationship include the following:

- 4.8 Preparing, maintaining, updating and implementing an Interface Management Plan,
- 4.9 Obtaining approval of the Interface Management Plan by other contractors and Esso,
- 4.10 Reporting monthly the status of interface issues and activities,
- 4.11 Scheduling, conducting and documenting periodic interface coordination meetings,
- 4.12 Identifying issues or activities to Esso and other contractors which are exceptions to the Interface Management Plan.

5.0 Contractor's Interface Management Plan

The Lead Contractor in an interface relationship shall submit within sixty (60) calendar days after date of Contract a preliminary Interface Management Plan for Esso's approval and for approval of interfacing contractors.

Recognizing that contract awards will not necessarily coincide, Contractor shall update the Plan within sixty (60) calendar days after a new Contract is awarded to incorporate the contractor's identified interfaces, deliverables and schedule. The Lead Contractor shall resubmit the Plan to Esso for approval and the interfacing contractor for concurrence. The Interface Management Plan shall include the following:

- 5.1 Contractor Interface Matrix updated for any additional interfaces identified,
- 5.2 List of interfaces, deliverables schedule and information requirements,
- 5.3 Plans for Interface Coordination Meetings including schedules, locations, meeting documentation and documentation distribution, including Esso on the distribution,
- 5.4 Listing of Interface Management Contacts for each Contractor,
- 5.5 Conflict resolution plans,
- 5.6 Procedures and correspondence distribution matrix for the flow of interface communication between all contractors involved including that with Esso.

TABLE 1
Interface Management Matrix

The Contractor indicated at the intersection of two Contracts in the matrix below is the Lead Contractor for the interface.

CONTRACT	FF	On P/L	PS	Off P/L	FSO	Road Upgrading	Telecom	Logistics
Field Facilities (FF) ²		FF	FF	-	-	-	T	L
Onshore Pipeline(On P/L)	FF		PS	On P/L	-	Road	T	L
Pump Stations(PS) ²	FF	PS		-	-	-	T	L
Offshore Pipeline(Off P/L)	-	On P/L	-		FSO	-	T	L
FSO ²	-	-	-	FSO		-	T	L
Road Upgrading (Road)	-	Road	-	-	-		T	L
Telecommunications(T) ²	T	T	T	T	T	T		L/T ¹
Logistics	L	L	L	Off P/L	FSO	L	L/T ¹	

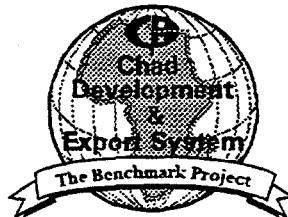
¹ Logistics Contractor is the Lead in the interface relationship with regard to Logistics services. Telecommunications Contractor is the Lead in the interface relationship with regard to Telecommunication services.

² Automation subcontractor interface issues will be incorporated into respective Contractor interface plans.

ESSO EXPLORATION & PRODUCTION CHAD INC.



CHAD DEVELOPMENT PROJECT



GENERAL PROJECT SPECIFICATION FOR CAMPS AND FACILITIES

GPS-001

Rev. No.	Date	No. of Pages	Prepared By	Reviewed By	Approved By	Revision Details
0	19 Nov 96	12	CKO	PRS	DJS	Issued for Proposals
1		12				Issued for Proposals
2	30 Oct 97	12	MEF	<i>PRS</i>	DJS	Issued for EMP



GENERAL PROJECT SPECIFICATION FOR
CAMPS AND FACILITIES

TABLE OF CONTENTS

1.0 INTRODUCTION 3

1.1 Camp Location 3

1.2 Camp Requirements 3

1.3 Camp Administrator 3

1.4 Drug and Alcohol Policy 4

1.5 Typical Problems/Issues 4

1.6 Smoking 4

1.7 Permits 4

2.0 CAMPS & FACILITIES 4

2.1 Scope 4

2.2 Construction and Supply Camps 5

2.3 Esso Representative(s) Living Quarters 5

2.4 Specifics for Contractor Living Quarters 7

2.5 Aircraft Runway and Heliport 10

2.6 Communications 10

2.7 Waste Management 11

2.8 Medical Service 12

2.9 Religious Customs 12

2.10 Demobilization 12



GENERAL PROJECT SPECIFICATION FOR
CAMPS AND FACILITIES

1.0 INTRODUCTION

Contractor's camp(s) for the Work shall be movable or shall be a fixed, temporary facility, whichever is most appropriate for its size and duration. With prior Esso approval, some distinction may be made between main and secondary camps with regard to level of services. Contractor's camp shall provide life support for essential Esso, Contractor and Government personnel and visitors and shall comply with all governing statutes and/or regulations and living standards of Chad and Cameroon. In the case of workers not accommodated in camps a housing allowance will be paid. As stated, all life support and logistical operations shall be conducted from Contractor's camp. Contractor shall store its permanent and consumable materials, supplies, and equipment within designated areas in or near the Camp—unless Contractor proposes a viable alternative, acceptable to Esso, or is instructed by Esso to locate this area in another location.

1.1 Camp Location

Camp(s), office facilities and storage areas should be in close proximity of the Work in order to adequately support the Work effort.

The exact location of camp(s), office facilities and storage areas will be agreed on between Esso and the Contractor after the award. Land will be obtained by Esso for use as camps by the contractor. The process of land acquisition is described elsewhere.

1.2 Camp Requirements

Camp(s) shall comply with all general project specifications including but not limited to General Security and Safeguards, Water Wells, Potable Water Treatment, Wastewater Treatment, and Landfill and Incinerator Design and Operation.

1.3 Camp Administrator

Contractor shall employ a Camp Administrator (with prior Esso approval, full or part-time, e.g. may be a combined Camp and Catering Administrator) with sufficient experience and authority to solve, in an expeditious manner, any problems or allegations which may arise with



**GENERAL PROJECT SPECIFICATION FOR
CAMPS AND FACILITIES**

expeditious manner, any problems or allegations which may arise with regard to the services, whether administrative or operational, covered in any of the specifications.

1.4 Drug and Alcohol Policy

The possession and/or consumption of alcoholic beverages is strictly prohibited. Possession and/or consumption may constitute grounds for dismissal. Drug and alcohol policy statement and implementation plan are provided in the Principal Document.

1.5 Typical Problems/Issues

Contractor shall consider and be aware of typical problems and issues including, but not limited to, handling of domestic or oily water and solid wastes, safe utilization and storage of pesticides, and ongoing monitoring of the quality of drinking and waste water. In addition, awareness of cultural differences, and the project policy prohibiting hunting and fishing in the project area are mandatory.

1.6 Smoking

Designated areas will be available for smoking. There will be no smoking in any of the living quarters.

1.7 Permits

Contractor(s) shall provide all requested details and requirements in support of its permit applications for Work Sites or other facilities. Contractor shall provide written notification to Esso for any deviation to originally submitted requirements so that adjustment can be made to current application.

2.0 CAMPS & FACILITIES

2.1 Scope

This specification applies to design and provision of camp(s) to be utilized during execution of the Work.



GENERAL PROJECT SPECIFICATION FOR
CAMPS AND FACILITIES

2.2 Construction and Supply Camps

Contractor shall furnish all camps, supplies, and living quarters, and provide all support necessary, including access roads/service, for Contractor personnel, suppliers, Esso personnel and visitors, and government personnel as per Section 1 of the Coordination Procedure - General Execution Requirements.

Contractor shall supply the following facilities and services at each of its camps:

- Nourishing food per Catering Services Specification GPS-002 for residing camp personnel.
- Bag-lunch for all personnel working outside of camp facilities.
- Recreational facility, NOT to include alcoholic beverage service.
- Mail service.
- Laundry services, per Catering Services Specification GPS-002, for residing camp personnel.
- Maintenance and janitorial service, per Catering Services Specification GPS-002.
- Waste Disposal according to Esso waste management facilities specifications and approved waste management plan (as per Coordination Procedure Section 30 - Environmental Management).
- Medical service, per Coordination Procedure 23 - Occupational Health, Medical Facilities and Sanitation.
- Security service in conformance with Esso's General Safeguards and Security Requirements, per Coordination Procedure 25 - Safeguards and Security (S&S) at Work Sites.

2.3 Esso Representative(s) Living Quarters

Contractor shall supply, and include in its contract price, temporary camp and office facilities for Esso personnel described herein and in Section 1 of the Coordination Procedure - General Execution Requirements.



GENERAL PROJECT SPECIFICATION FOR
CAMPS AND FACILITIES

2.3.1 Base Camps

Living quarters, dining facilities, laundry services, janitorial services and all other services described or listed in specifications in this contract, shall be supplied by the Contractor, in the quantities specified in Section 1 of the Coordination Procedure.

Following are specifics:

- Esso personnel shall be provided with single occupancy quarters which include a complete bathroom in each quarter and which are free of insects, rodents, and vermin.
- Each living quarter shall be complete with heating, ventilation, and air conditioning (HVAC), sink, mirror/cabinet, toilet, shower, lighting, electrical outlets (one ground-fault protected near sink), smoke detector, fire extinguisher, window(s), and locking entrance door. Each living quarter shall be outfitted with screen doors and windows, bed, mattress, pillow, sheets, blanket(s), bath towel(s), chair, desk, lamp, shelving, closet. Bed linens, towels and bath soap shall be changed twice weekly. Each living quarter shall be serviced daily, this to include as a minimum: making of bed, disposing of trash, general dusting, wipe-down of sink/mirror, disinfectant-clean of toilet, broom-clean/vacuum/mop of floor.
- All buildings should be made as insect-proof as possible by sealing the gaps between units and any spaces between air conditioners and buildings. All window screens of a mesh size appropriate for the insects of the area should be in place and checked for tears. Strips 4 cm wide, impregnated with insecticide (permethrin), should be hung in doorways to help with mosquito/fly control in buildings. Permethrin is available from Graniteville Co., Graniteville, SC (803) 663-5261, and other sources.
- Bednets should be provided for each worker and for guards in their tents.



GENERAL PROJECT SPECIFICATION FOR
CAMPS AND FACILITIES

2.3.2 Offices

Contractor shall furnish offices for Esso's personnel and visitors as required by Section 1 of the Coordination Procedure - General Execution Requirements.

Office space shall be sub-divided to provide the number of private and shared offices specified in the Coordination Procedure. A minimum of 9 m² will be allocated for each individual in an office. In addition, space shall be provided for conference room, work stations, restrooms (male and female, as appropriate), reception and open area(s). The facility shall be equipped with appropriate HVAC, sinks, urinals, toilets, lighting, electrical outlets, fire detectors, fire extinguishers, windows, and locking exterior door(s). The facility shall be provided with standard office furnishings (e.g., desks, chairs, filing cabinets and bookcases), equipment (including drawing racks, water fountain, coffee maker, and photocopier(s) with paper), and all office supplies and project stationery. Janitorial service shall be provided (as applicable from living quarters cleaning detail) on a daily basis.

2.4 Specifics for Contractor Living Quarters

Assignment of living quarters for Contractor personnel (North American, European, Chadian, Cameroonian, and others) are to be based upon general criteria relative to skill level: skilled, semi-skilled, unskilled.

2.4.1 Capacity

The maximum number of persons to each living quarter shall be calculated so that each bed corresponds to a rectangle of 1.6 X 2.3 meters (approximately 5 X 8 ft) with a distance between beds of 80 cm. Triple deck bunks are not allowed in the living quarters.

2.4.2 Ventilation

Fan or HVAC shall be provided to enhance circulation. Windows, vents, and doors shall be protected by screen mesh.



GENERAL PROJECT SPECIFICATION FOR
CAMPS AND FACILITIES

2.4.3 Doors

Doors shall have unique locks (either keyed or automatic, punch-coded locks) and shall open from within (outwardly).

2.4.4 Floors

Living quarters shall not have a natural ground surface.

2.4.5 Mosquito Netting

All sleeping areas will be equipped with individual mosquito netting. Bednets should be dipped and washed in a solution of cold water with 2.5% deltamethrin or permethrin to provide adequate protection. After washing, the bednets should be air dried before being returned to the sleeping areas.

Mosquito netting shall also be provided for guards in their tents.

2.4.6 Restrooms and Ablution Blocks

Contractor shall provide washrooms and other facilities, as necessary, to satisfy the religious needs and customs of its work force.

Washrooms shall be located and sized based upon camp population and shall include adequate lighting and appropriate numbers of facilities. Separate facilities shall be provided for men and women. As a minimum, the following shall be provided:

- toilets - 1 per 15 persons
- urinals - 1 per 25 men
- shower stalls (stainless steel) - 1 per 10 persons
- washbasins and mirrors - 1 per 4 persons

In general, washrooms shall be constructed in well-ventilated areas, and supplied with an adequate amount of hot and cold water (potable), toilet paper and holders, waste receptacles, and deodorant.



GENERAL PROJECT SPECIFICATION FOR
CAMPS AND FACILITIES

2.4.7 Potable Water Supply

The potable water supply shall be designed and tested according to standards of the World Health Organization; see Potable Water Treatment, Storage and Distribution (Temporary) Specification, GPS-003. Potable water shall be supplied to all showers and sinks located in kitchens, bathrooms, and offices. All camp taps shall deliver potable water.

2.4.8 Electrical Power

For security purposes, there shall be a redundant (backup) source of electrical power, independent of the primary power source. Camp power shall adequately supply all electrical requirements.

2.4.9 Fuel Storage

Storage of flammable liquids (diesel and gasoline) shall be in above-ground storage tanks located in properly lined and bunkered holding areas. Unless an alternative remediation method is provided for in the Esso - approved Contractor Waste Management Plan, contaminated soil associated with vehicle fueling operations will be promptly collected and stored until it can be properly disposed. All flammable liquid storage areas shall be located a suitable distance from all manned facilities.

2.4.10 Kitchen

See Catering Services Specifications, GPS-002.

2.4.11 Dining Area

All windows and doors shall be protected by mesh screen and shall be kept in good condition. Doors shall be automatically closing (e.g., by coil spring or spring and hydraulic piston.) Dining areas, living quarters, and restrooms shall be located in close proximity to each other.



GENERAL PROJECT SPECIFICATION FOR
CAMPS AND FACILITIES

2.4.12 Recreational Facilities

Contractor shall provide off-hours recreational facilities for Contractor and Esso employees and camp guests. Facilities may include an area(s) for organized team sports such as basketball and soccer and/or indoor exercise equipment, as appropriate for the size and duration of the camp.

In addition, Contractor shall provide a recreational room(s) to include but not be limited to television(s), VCR(s), satellite dish(s), short wave radio(s), and books and periodicals in appropriate languages.

2.4.13 Control of Insects and Rodents

Pest control is the Contractor's responsibility. Contractor shall utilize insecticides and pesticides approved by the Esso Medical Department.

Insecticides and pesticides shall be utilized in a controlled manner so as to avoid contamination of food and personnel. The Contractor shall emphasize insect and rodent control, making sure that garbage areas are clean. Contractor will take immediate action if a rodent situation should arise in the facilities.

2.5 Aircraft Runway and Heliport

At main camps and storage yards, a helipad is required if there is not an existing aircraft runway located within 30 minutes by ground transport. The camp helipad will be in close proximity to the secured areas of the facility, and be convenient for urgent air medical or security evacuation. Contractor shall present a plan, subject to Esso approval, outlining aircraft availability and emergency transportation plans.

2.6 Communications

A means of voice, fax, and data transfer capability is required, to enable personnel to communicate between the various camps and facilities. Esso intends to provide, (except for early project work activities - i.e. infrastructure and telecom) as part of its overall project support a reliable telecommunications system to provide the above capabilities at each of the project locations. See Coordination Procedure Section 28, Telecommunications.



GENERAL PROJECT SPECIFICATION FOR
CAMPS AND FACILITIES

2.7 Waste Management

All waste shall be handled and treated in accordance with the Waste Management Guidelines GPS-011, Environmental Impact Mitigation Specifications, and Coordination Procedure Section 30 - Environmental Management.

2.7.1 Liquid Waste

Sanitary sewage shall be handled by a Wastewater Treating Plant (see Packaged Sewage Treatment System (Temporary) Specification GPS-004) which will be sized according to camp population such that effluent undergoes sufficient treatment to be suitable for discharge to surface waters (free of bacteriological and organic pollutants). Alternatively, for small camps a septic tank system with effluent disposal into a drainage field may also be suitable (specifications are given in GPS-018 for those contracts for which septic systems may be applicable). Other water treatment systems may be approved by Esso if the treatment standards of the Environmental Impact Mitigation Specification will be satisfied.

2.7.2 Solid Waste

Contractor's Waste Management Program shall provide a mechanism for disposal of all solid waste products avoiding social, economical, and ecological/environmental problems, and protecting aesthetics and health.

Prior to mobilization, Contractor will prepare and submit, for Esso approval, a Waste Management Plan as per Section 30 of the Coordination Procedure - Environmental Management. Solid waste will be disposed of per Contractor's Waste Management Plan which shall be consistent with Esso specifications and guidelines for waste management practices and treatment and disposal facilities.

The following requirements will also apply:

- Trash and rubbish shall be collected on a schedule that does not allow for accumulation of trash in bins, with an adequate number of wheeled and well-sealed large bins having been placed by contractor.



**GENERAL PROJECT SPECIFICATION FOR
CAMPS AND FACILITIES**

- Bins shall be washed daily using disinfectant.
- Construction debris shall be separated and disposed of in proper manner, depending on the origin and condition. Recycling and reuse opportunities will be used where practical.

2.8 Medical Service

All health/medical service issues will be consistent with Esso's Health Plan, and Medical Service Guidelines for Remote Sites (GPS-010) and will be approved by Esso prior to mobilization.

Contractor shall submit for Esso approval, a medical plan including the number of doctor(s), physicians assistant(s), and nurse(s) to be utilized for the planned work force and staff in addition to planned sickbay facilities. The medical plan requirements are provided in Section 23 of the Coordination Procedure - Occupational Health, Medical Facilities and Sanitation.

2.9 Religious Customs

Contractor shall provide prayer rooms and other facilities, as necessary, to satisfy the religious needs and customs of its work force.

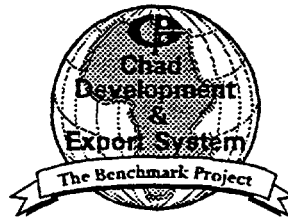
2.10 Demobilization

- 1) Before demobilization of any camps or facilities, Contractor shall submit a demobilization plan for Esso's review and approval.
- 2) Esso reserves the right to request non-demobilization of any or all temporary facilities.
- 3) Contractor shall be responsible for complete restoration of areas utilized for camps and storage areas not needed by subsequent project contractors to their original state, in accordance with the Environmental Impact Mitigation Specification (CCS-21-20-108).
- 4) A final demobilization inspection will be completed by Esso and Contractor prior to site release.

ESSO EXPLORATION & PRODUCTION CHAD INC.



CHAD DEVELOPMENT PROJECT



GENERAL PROJECT SPECIFICATION FOR CATERING SERVICES

GPS-002

Rev. No.	Date	No. of Pages	Prepared By	Reviewed By	Approved By	Revision Details
0	19 Nov 96	20	CKO	PRS	DJS	Issued for Proposals
1	19 Jun 97	20				Issued for Proposal
2	30 OCT 97	20	MEF	<i>PRS</i>	DJS	Issued for EMP



GENERAL PROJECT SPECIFICATION FOR
CATERING SERVICES

TABLE OF CONTENTS

1.0 PURPOSE.....4

1.1 Overview 4

1.2 Planning and Execution 4

1.3 Drug and Alcohol Policy 4

1.4 Overall Scope of the Services 5

 1.4.1 Meal Service 5

 1.4.2 Sanitation of Facilities and Garbage Collection, Segregation and Disposal ... 5

 1.4.3 Coffee Service 5

 1.4.4 Lodging, Laundry and Ironing Service 5

1.5 Contractor Personnel Requirements 6

 1.5.1 Hiring and Periodic Medical Examinations 7

1.6 Training 8

1.7 Reporting 8

 1.7.1 Cleanup and Cafeterias 8

 1.7.2 Personnel Administration 9

1.8 Equipment, Spare Parts and General Goods to be Supplied by Contractor 9

 1.8.1 Equipment 9

 1.8.2 Vehicles 9

 1.8.3 Spare Parts 9

 1.8.4 Refrigeration Units 9

 1.8.5 HVAC 9

 1.8.6 Exhaust Fans and Filtered Ventilation 10

 1.8.7 General Goods 10

 1.8.8 Maintenance 10

 1.8.9 Floor Surface 10

 1.8.10 Table Tops and Counter Tops 11

2.0 SPECIFIC OBLIGATIONS FOR EACH SERVICE11

2.1 Meal Service 11

 2.1.1 Test Sampling of Food 11

 2.1.2 Food Transportation and Storage 11

 2.1.3 Regulations and Specifications for Providing the Service 11

 2.1.4 Menus 15

 2.1.5 Noxious Food 15

 2.1.6 Coffee Service 15

 2.1.7 Quality Control 15

2.2 Cleaning and Sanitation 16

 2.2.1 Services and Schedule 16

 2.2.2 Overall Requirements 17

 2.2.3 Washing and Ironing Service Requirements 18



GENERAL PROJECT SPECIFICATION FOR
CATERING SERVICES

2.2.4 Housekeeping Service Requirements..... 18
2.2.5 Requirements for Garbage Collection, Segregation and Disposal..... 18
2.2.6 Control of Insects and Rodents 19
2.2.7 Special Facilities Sanitation Service - Medical Center 19



GENERAL PROJECT SPECIFICATION FOR
CATERING SERVICES

1.0 PURPOSE

Contractor will provide Esso and Contractor employees and visitors with meal, laundry, housekeeping and office cleaning services at project camps as per Section 1 (General Execution Requirements) and Section 29 (Socioeconomic Interactions) of the Coordination Procedure.

1.1 Overview

The services will entail materials, food, supplies, labor, supervision and all that is needed to perform these services, including: meal preparation, housekeeping, garbage/waste collection, segregation, storage and incineration. In addition, Contractor shall be responsible for cleanliness and sanitation of cafeteria(s), offices, recreation areas, personnel housing, medical center, warehouse and workshop areas, parking areas, and guardhouses. All services will be performed according to requirements of the Job Specification. With prior Esso approval, some distinction may be made between main and secondary camps with regard to level of services.

1.2 Planning and Execution

Contractor shall employ all the resources and personnel required for planning, scheduling and estimating materials, equipment and goods, including all supplies, foodstuffs, cleaning elements and other equipment needed for the efficient, safe and hygienic performance of the services. Contractor shall have plans prepared, prior to mobilization, for Esso approval, that provides for foodstuffs, meals and the maintenance of all equipment required in the operation. Contractor must also present at the same time, to Esso, its updated procedure manuals for each of the activities.

Likewise, Contractor must have personnel to properly manage the purchasing, transportation, receipt and storage of all foodstuffs, materials, equipment, and goods required to provide a proper service.

1.3 Drug and Alcohol Policy

The possession and/or consumption of alcoholic beverages is strictly prohibited. Possession and/or consumption may constitute grounds for dismissal. Drug and alcohol policy statement and implementation plan are provided Principal Document.



**GENERAL PROJECT SPECIFICATION FOR
CATERING SERVICES**

1.4 Overall Scope of the Services

Contractor will provide the following services:

1.4.1 Meal Service

Contractor will provide, at no cost to employees, meal services in Contractor operated and managed cafeterias, at all camps. This will include purchasing, preparing, serving and cleaning up.

1.4.2 Sanitation of Facilities and Garbage Collection, Segregation and Disposal

Contractor will perform all cleaning services, as well as those of garbage collection, segregation, incineration, transportation, and disposal, at all facilities under its charge. Said activities shall be performed according to procedures agreed to by Contractor and Esso prior to mobilization.

1.4.3 Coffee Service

Contractor will provide coffee service as described in 2.1.6.

1.4.4 Lodging, Laundry and Ironing Service

Contractor shall assign lodging and shall limit access to only authorized personnel. Project personnel shall be supplied with a clean supply of linens and cleaning implements for personal use. These items shall include but not be limited to: a set of bedding for single bed (bottom sheet, top sheet and pillow case), quilt, blanket, hand and body towels, floor mat, mattress cover, unscented soap, shower curtain, potable water and disposable cups. Keys and key holders will be replaced at Contractor's expense when lost by personnel requiring them.

Laundry and shower areas which can provide resting sites for adult mosquitoes should be sprayed every 3 days with chemical grade



GENERAL PROJECT SPECIFICATION FOR
CATERING SERVICES

CHEM REZ-25 or deltamethrin using hand-held sprayers. Spraymen should wear goggles, nitrile-gloves, and a respirator during mixing and application.

Outer clothing of workers should be treated with deltamethrin or permethrin by the laundry personnel. Dipping and washing clothes in a solution of cold water with 2.5% deltamethrin or permethrin should provide adequate protection against mosquitoes. After washing, the clothes should be air dried before being returned to the workers. Deltamethrin or permethrin will not fade or stain clothing, and it will not leave a noticeable odor. It remains protective through up to 40 washings with hot water and soap.

Bednets should be treated with deltamethrin or permethrin as described above for clothing. They should be kept closed around beds at all times, even when no one is sleeping in the bed. Bednets should be treated with deltamethrin or permethrin every 3 months.

Washing, drying, and ironing of all clothing and bedding from the Medical Center must be done separately from the laundry of the camp residents.

Biodegradable soaps and detergents are mandatory. All laundry will be treated with permethrin or deltamethrin insecticide. Laundry bags will be kept in each of the rooms for persons staying overnight at the camps, in order to provide them with the laundry service.

All clothing and bedding will be ironed with a hot iron prior to returning to camp personnel.

1.5 Contractor Personnel Requirements

Contractor shall employ a Catering Administrator (with prior Esso approval, full or part-time, e.g. may be a combined Camp and Catering Administrator) with sufficient experience and authority to solve, in an expeditious manner, any problems or claims which may arise with regard to the services, whether administrative or operational, covered in the specifications.

It is the Contractor's obligation to maintain, within the minimum personnel required, one (1) kitchen Chef (Head Cook) and one (1) nutritionist or food engineer on a full or part-time basis, for the duration of camp operations.



**GENERAL PROJECT SPECIFICATION FOR
CATERING SERVICES**

1.5.1 Hiring and Periodic Medical Examinations

Hiring medical examinations must be performed on all food handlers according to the legal requirements and the Job Specifications. Emphasis shall be placed on contagious diseases, dermatological and respiratory problems, gastric disorders and oral infections.

This information must be recorded in the personnel medical records, especially designed for this purpose.

Hiring Exams for Non-Food Handling Personnel:
(lodging, laundry and ironing service)

- General medical examination (stating the absence of infectious or contagious diseases and of skin ailments)

Hiring Exams for Food Handling Personnel:

- General medical examination (stating the absence of infectious or contagious diseases and of skin ailments)
- Urinalysis
- Complete blood count
- Thoracic X-ray and electrocardiogram as indicated
- Microscopic exam of fresh stool for ova and parasites

Periodic Examinations:

- Exam periods shall be determined by the risks. At a minimum, exams must be carried out quarterly.
- Esso reserves the right to perform directly or through third parties, whatever medical examinations it considers necessary and to modify the requirements mentioned whenever it considers that it is necessary.
- A copy of each catering service employee's clinical history will be forwarded to Esso's Medical Department. Contractor will keep the originals which will be available for Esso's inspection. These are confidential documents and Contractor is responsible for handling them in a secure manner.



**GENERAL PROJECT SPECIFICATION FOR
CATERING SERVICES**

- Contractor is required to immediately report any illness or injury of food handlers to Esso's Medical Director and to report any corrective actions taken to verify the quality of the food supply.
- Esso reserves the right to request Contractor to withdraw from service any personnel who, in Esso's judgment, represents a health risk.

1.6 Training

If Contractor elects to utilize local/national labor in the execution of catering services he shall be responsible for training to include but not be limited to the following:

- Personal hygiene
- Facility sanitation and disinfection
- Housekeeping service regulations
- Food storage, preparation and service standards
- Basic laundry practices
- Laundry practices for contaminated medical garments
- Garbage collection, segregation and disposal
- Proper procedures for control of insects and rodents
- Insecticide usage

1.7 Reporting

Contractor will submit succinct reports, as per the formats established by Esso for such purposes, to the Esso site manager for the following items:

1.7.1 Cleanup and Cafeterias

Monthly scheduling of the cleanup brigades, particularly for disinfecting and pest control, to be carried out in the various facilities in Contractor's charge.

Weekly reports of inspections carried out on the catering facilities, along with a listing of any irregularities found and corrective action implemented.



**GENERAL PROJECT SPECIFICATION FOR
CATERING SERVICES**

1.7.2 Personnel Administration

Monthly reports on the following:

- Hiring and termination of personnel,
- Personnel training (indicating content and duration of course), and
- Occupational health activities.

1.8 Equipment, Spare Parts and General Goods to be Supplied by Contractor

1.8.1 Equipment

It is Contractor's responsibility to provide all equipment, spare parts and general goods required for the performance of the services.

1.8.2 Vehicles

It is the Contractor's responsibility to provide vehicles for the transportation of Contractor personnel, materials and everything relating to the performance of these services.

The required vehicles must meet all industrial and project safety regulations defined in Coordination Procedure 22 - Project Safety Practices.

1.8.3 Spare Parts

Contractor will supply all the spare parts required to perform maintenance on its equipment.

1.8.4 Refrigeration Units

Contractor shall provide adequate walk-in freezers and refrigerators sufficient to properly provide safe cold storage. Large units shall have a functioning thermometer.



GENERAL PROJECT SPECIFICATION FOR
CATERING SERVICES

1.8.5 HVAC

Contractor shall provide adequate air-conditioning units for both kitchens and food serving/ dining areas.

1.8.6 Exhaust Fans and Filtered Ventilation

Contractor shall provide adequate exhaust fans and frequently cleaned filtered ventilation systems for both kitchen and dining areas. These must be of appropriate size to effectively provide ventilation.

1.8.7 General Goods

Contractor must supply, among other things: kitchen materials and implements (pots and pans, appliances, etc.), napkins, disposable cups, aluminum foil, plastic wrap, drinking water bottles, plastic garbage containers with lids, garbage bags and clear bags for food storage, waste paper baskets for restrooms, mops, brooms, polishers, buckets, deodorizers, detergents, disinfectants, toilet paper, plastic bags for sanitary napkin disposal, unscented soap with wrapper, liquid soap and dispensers, paper hand towels and dispensers for restrooms and paper towel rolls for food handlers and any other elements needed for the satisfactory performance of the catering services. Cloth towels are to be avoided in food preparation and food serving areas.

The following dining room general items, although not exclusively, shall be supplied: break-resistant tableware, flatware and trays; condiments; napkins; toothpicks; table cloths and linen. Sinks, brushes, soap and paper towels for hand washing must be provided in the immediate mess area.

1.8.8 Maintenance

It is Contractor's responsibility to perform a proper maintenance to guarantee the operability and long life of the equipment.

The use of garbage disposal units is prohibited in the kitchen.



GENERAL PROJECT SPECIFICATION FOR
CATERING SERVICES

1.8.9 Floor Surface

Kitchen and food preparation area floors must be non-porous and be surrounded by mop-board type molding at least 10 cm (4 inches) in height to facilitate frequent disinfectant mopping.

1.8.10 Table Tops and Counter Tops

Contractor must surface all tables and counters in food service and food preparation areas with non-porous covering suitable for frequent disinfectant cleansing.

2.0 SPECIFIC OBLIGATIONS FOR EACH SERVICE

2.1 Meal Service

Meal services consist of providing balanced meals and nutrition of optimum organoleptic and microbiological quality.

2.1.1 Test Sampling of Food

Bacteriological tests must be performed periodically at the location during each phase of food preparation.

2.1.2 Food Transportation and Storage

Contractor must guarantee an adequate system of purchasing, transporting, preserving and handling of foodstuffs from supply point or source to the camps observing the minimum and maximum temperature and humidity conditions required for each type of food, so as to preserve these foodstuffs in optimum conditions of quality. All foodstuffs must be transported and stored observing reasonable health procedures.

2.1.3 Regulations and Specifications for Providing the Service

2.1.3.1 Meals

Contractor will provide, prepare and serve breakfast, lunch and dinner every day and to each person residing in the camp(s) and to guests authorized by Esso. Furthermore,



**GENERAL PROJECT SPECIFICATION FOR
CATERING SERVICES**

lunches shall be provided to all employees who are not camp residents. Coolers will be provided, if necessary, to ensure that lunches in the field do not spoil.

Contractor shall provide meals to disabled personnel in rooms or Medical Center.

2.1.3.2 Temperature

Food temperature at time of serving must be consistent with U.S. Public Health Service (USPHS) Requirements or other similar international standards agreed to by Esso's representative.

2.1.3.3 Spoiled Food or Food with Past Expiration Dates

Contractor may not utilize food with past expiration dates or food that is deteriorated or spoiled.

Esso reserves the right to inspect foodstuff warehouses and storage places for the purpose of verifying that the foodstuffs stored there do meet the minimum requirements mentioned above.

In the event that Esso officials find food with expired dates or deteriorated or spoiled food, they will proceed, together with Contractor, to destroy the products.

2.1.3.4 Meals According to Religious or Ethnic Custom

Contractor shall operate kitchens and meal service to meet the demands of a diversified multi-national work force.

To the extent possible, Contractor will purchase foodstuffs nationally. Under no circumstances shall "bushmeat" or wild game be purchased for preparation in the camp kitchens and served in camp cafeterias.

2.1.3.5 Food Supplies

Contractor must keep a record of stock inventories, which must be available for periodic inspections by Esso.



**GENERAL PROJECT SPECIFICATION FOR
CATERING SERVICES**

The main warehouse will be the site assigned to store, classify and wash the foodstuffs, as required. The receptacles utilized for holding food must be washed hygienically before use.

Contractor must carry out disinfecting in the cold storage rooms at least once a week or whenever requested to do so by Esso.

2.1.3.6 Food Service Hygiene

Contractor must:

- Handle food according to the highest sanitary and hygienic standards developed by the USPHS or similar international standard agreed to by Esso's representative.
- Enforce hygiene and cleanliness standards for all food services personnel, ensuring that they wash their hands before handling food. To this end, there must always be liquid soap, disposable towels, finger nail brushes, and disinfectant available for washing hands.
- Keep its personnel supplied with uniforms, shoes, caps and cook's hats, hair nets, face masks and gloves for handling food. In addition, the personnel must be supplied with the following protective gear: Gloves for food handling, protective gloves for cutting operations, plastic boots and aprons for washing and disinfecting the cafeterias.
- Ensure that the personnel tending to the service line use white aprons, different from those utilized during the food preparation.
- Make available the procedures manual for the cleaning and disinfecting of utensils, dinnerware, silverware, tables and hot tables, freezers, etc., to be utilized in the performance of the Contract. These procedures may be modified in agreement with Esso.



GENERAL PROJECT SPECIFICATION FOR
CATERING SERVICES

2.1.3.7 Tidiness and Cleanliness

Contractor must clean, tidy up and disinfect all facilities under its care and in so doing bear the responsibility of upholding the highest standards of cleanliness, neatness and hygiene. Esso will carry out periodic inspections at its facilities and will forward any pertinent observations, which shall immediately be addressed by Contractor.

Cleaning, disinfecting and tidying up will be done on tables, places where food is processed, chairs, grills and equipment in general, after every serving, utilizing biodegradable disinfectants and detergents.

Kitchen equipment and utensils, including silverware, dinnerware and glasses will be washed with biodegradable detergents and disinfectants after each serving. The grease collector, the smoke exhaust funnels and the ventilators in the kitchen and cafeteria, will be cleaned at least once a week or more often, as needed.

The freezers, cold storage rooms and storage cupboards will be kept clean and disinfected according to the highest standards of cleanliness and free of residue and garbage. Special attention will be paid to pest and rodent prevention in the storage and bakery areas.

Contractor must clean the cafeteria tables and chairs before, during, and after each meal. The floors will be wet-mopped after each serving, washed during the day and scrubbed at least once a week. The windows must be cleaned at least once a month. Kitchen utensils and implements, dinnerware and silverware must be washed and sterilized after each serving. Refrigerators, foodstuff storage places, vegetable preparation rooms, etc., must be kept clean and waste free. Any screen-wire utilized on doors and windows must be kept in excellent repair.

Contractor must make a diligent effort to keep the cafeteria and kitchen areas free of flies, mosquitoes and other insects, rodents and other pests.



**GENERAL PROJECT SPECIFICATION FOR
CATERING SERVICES**

All public restrooms must be cleaned at least two (2) times per day. Restrooms must be kept supplied with protective paper toilet seat covers, toilet paper, paper towels, liquid soap and dispensers. Biodegradable detergents must be used, to uphold the highest degrees of hygiene and environmental protection.

The floors, baskets and trash and garbage receptacles must be washed and disinfected daily. Garbage receptacles must be covered when not in use and kept at a distance from the food handling and processing areas.

2.1.4 Menus

Contractor shall offer balanced menus for breakfast, lunch and dinner, incorporating recommendations made by the nutritionist.

2.1.5 Noxious Food

Esso reserves the right to determine which ingredients in the preparation of the meals are harmful to health and to prohibit the use of said products.

2.1.6 Coffee Service

Contractor shall provide free coffee and tea in the camps at designated locations. The designated coffee areas shall have related supplies and shall be kept in a state of cleanliness and hygiene at all times.

2.1.7 Quality Control

Contractor must create and implement a Quality Control system for all products associated with camp food supplies, meal preparation and sanitation; in particular, perishable goods or those classified as having a high epidemiological risk. Said system must control, at least, the following:

- The fixing of organoleptic or physical-chemical parameters for fruits, meats, eggs and milk products. This will include washing fruits, vegetables, etc. in potassium permanganate, or chlorine solutions to kill disease causing organisms.



**GENERAL PROJECT SPECIFICATION FOR
CATERING SERVICES**

- Controls for perishable foodstuffs to include an ongoing verification of the packaging of said products and the conditions of transportation.
- Inspection of the system, handling and quality of frozen meats and fish.

There will be at least one Contractor representative present in the cafeteria during meals, who will be responsible for the promptness and efficiency of the service.

2.2 Cleaning and Sanitation

2.2.1 Services and Schedule

The services described below include, but are not limited to: all materials, articles, food products, supplies, labor, and supervision necessary to provide the services of cleaning, sanitation and hygiene, garbage collection and recycling, at the sites mentioned in Section 1.1 as well as room, laundry, and cafeteria services.

Service	Frequency	Comment
Cafeteria Service	7 days a week	according to schedules which adjust to the needs of project operations
Laundry	6 days a week	according to schedules which adjust to the needs of project operations
Garbage Collection, Segregation and Disposal	7 days a week	
Sanitation and Cleaning	7 days a week	The Contractor shall: <ul style="list-style-type: none"> • Sweep, mop, dust daily and wash weekly or more frequently, if needed. Debris will be removed as necessary. • Periodically wash the walls, windows, ceilings and doors



GENERAL PROJECT SPECIFICATION FOR
CATERING SERVICES

2.2.2 Overall Requirements

Contractor must fulfill the following general requirements, as a minimum, for the performance of the sanitation and cleanup services being considered in this section. It is also its responsibility to carry out periodic inspections in order to guarantee compliance with said standards:

DUTIES	PERFORMANCE STANDARD
Refrigerators	Must be kept clean and free of frost.
Water Fountains	Water fountains must be kept clean and disinfected. Obstacles must be removed and leaks repaired immediately.
Sweeping	A well-swept floor should not show signs or dust pan tracks. Dirt should not be left in the corners, behind the doors or under the carpets or furniture. Cleaning equipment and implements must be put back in their place. Rooms must be left in an orderly fashion.
Mopping	Floors must be scrubbed with a damp cloth (not wet) and a mop with cleaning solutions (detergents, bactericides deodorizers or similar products).
Wall Washing	There must be no visible streaks nor markings. Wood panels, as well as corners and other hard-to-reach areas must be clean.
Vacuuming	If carpeted, personnel rooms and medical facilities must be vacuumed twice weekly.
Restrooms	Restroom areas must be scrubbed and disinfected twice daily. Toilets, basins and urinals must be kept clean inside and out.
Trash Removal	All areas where trash, waste, sand, etc., tend to gather, as well as access ways, passageways, flat areas, must be kept cleared.



GENERAL PROJECT SPECIFICATION FOR
CATERING SERVICES

2.2.3 Washing and Ironing Service Requirements

Laundry services will be operated for everyone staying at Contractor's camp.

Laundry facilities are to include procedures and provisions for permeation of clothing, barrier curtains, uniforms, mosquito nets, and other designated materials with Esso approved insect repellent solutions (generally Permethrin based).

Laundry procedures will include the following tasks: hot iron all washed items; sweep, mop, dust, and constantly remove accumulations of lint and fibers from the washers and dryers; maintain the laundry equipment free from detergent, soap and chemical residue used in the laundry process.

Clothing from the medical center must be handled separately and the utmost care and control must be exercised in its disinfection. Chlorine bleach and hot wash cycles are to be used.

2.2.4 Housekeeping Service Requirements

Housekeeping service must include cleaning of the housing module, sweeping and waxing of floors, making of beds, complete cleaning of each bathroom, change of soap and a supply of toilet paper, as required, change of bed clothing and towels at least two (2) times a week.

2.2.5 Requirements for Garbage Collection, Segregation and Disposal

Contractor will collect garbage and wastes daily or more often if necessary, at the following locations: kitchen, living areas, offices and workshops described in the terms of the CONTRACT, common areas and access ways. Garbage and wastes will be deposited in cans and containers until they are picked up, bearing in mind the following potential segregation categories:

- Paper
- Plastic
- Glass
- Non-Ferrous Metals
- Wood
- Ferrous Metals
- Food Products



**GENERAL PROJECT SPECIFICATION FOR
CATERING SERVICES**

Contractor is obligated to apply Esso's requirements concerning garbage, including collection, storage and disposal, as stated in Section 30 of the Coordination Procedure - Environmental Management.

2.2.6 Control of Insects and Rodents

Contractor shall emphasize insect and rodent control as a major priority, daily ascertaining that garbage areas are clean and free of rodent signs. Immediate action must be taken should a rodent situation arise in the camp.

* All pesticides must be approved by Esso prior to purchase, storage or use.

Cleaning will include the application of insecticides and disinfectants approved by Esso. It is mandatory to utilize household-type insecticides and baits, excluding pest and rodent control services in outside areas and general fumigation in the entire plant.

Dirty or standing water and organic residues produced by the kitchen and food service areas will be disposed of on a daily basis. Holes and depressions that could trap standing water shall be filled.

2.2.7 Special Facilities Sanitation Service - Medical Center

Facility Sanitation and Disinfecting

Sanitation and disinfecting of these facilities will be defined by Esso's Health, Safety, Environmental (HSE) personnel, in coordination with Contractor's personnel. At a minimum, medical facility must be mopped with disinfectant detergents two (2) times per day. Additional mopping will be carried out as requested and under the direction of medical personnel.

It is important that cleaning implements utilized in the Medical Center not be utilized outside this facility.



GENERAL PROJECT SPECIFICATION FOR
CATERING SERVICES

Collection, Washing, Ironing and Delivery of Clothing

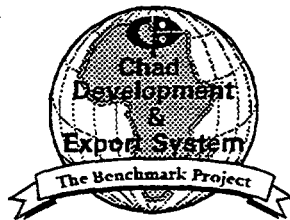
The procedure for Medical Center laundry collection, washing, ironing and delivery is to be performed separately from other camp laundry (a separate washer, dryer and iron must be employed). HSE will define other recommendations on this particular process to Contractor.

Cleaning of facilities must be done at least two (2) times per day.

ESSO EXPLORATION & PRODUCTION CHAD INC.



CHAD DEVELOPMENT PROJECT



GENERAL PROJECT SPECIFICATION FOR POTABLE WATER TREATMENT, STORAGE AND DISTRIBUTION (TEMPORARY)

GPS-003

Rev. No.	Date	No. of Pages	Prepared By	Reviewed By	Approved By	Revision Details
0	19 Nov 96	11	FRE/CKO	PRS	DJS	Issued for Proposals
1	30 Oct 97	11	MEF	PRS	DJS	Issued for EMP



GENERAL PROJECT SPECIFICATION FOR
POTABLE WATER TREATMENT, STORAGE AND DISTRIBUTION (TEMPORARY)

TABLE OF CONTENTS

1.0 SCOPE.....3

2.0 SUMMARY OF ADDITIONAL REQUIREMENTS3

3.0 SYSTEM DESIGN.....4

4.0 WATER TREATMENT.....4

5.0 TREATED WATER STORAGE TANK.....5

6.0 WATER PRESSURE TANK.....5

7.0 POTABLE/UTILITY WATER DISTRIBUTION PUMPS7

8.0 POTABLE WATER DISTRIBUTION SYSTEM.....7

9.0 VALVES.....8

LIST OF TABLES

Table 1 Reference Documents.....3

Table 2 World Health Organizational Guidelines for Drinking Water
Quality9



**GENERAL PROJECT SPECIFICATION FOR
POTABLE WATER TREATMENT, STORAGE AND DISTRIBUTION (TEMPORARY)**

1.0 SCOPE

This Specification covers the functional requirements for temporary potable/utility water treatment, storage and distribution systems to be used by Contractor on the Work Site during the Work.

2.0 SUMMARY OF ADDITIONAL REQUIREMENTS

Table 1 lists the standards and specifications which shall be used with this Specification.

TABLE 1. Reference Documents

American Society of Mechanical Engineers (ASME) Standards	
Boiler and Pressure Vessel Code, Section VIII, Div. 1, Pressure Vessels	
American Society for Testing and Materials (ASTM) Standards	
B88	Seamless Copper Water Tube
F441	Chlorinated Poly(Vinyl Chloride) (CPVC) Plastic Pipe, Schedules 40 and 80
A53	Pipe, Steel, Black and Hot-Dipped, Zinc Coated, Welded and Seamless
American Water Works Association (AWWA) Standards	
B300	Hypochlorites
C508	Check Valves
C651	Disinfection of Water Mains
C652	Disinfection of Water Storage Facilities
C653	Disinfection of Water Treatment Facilities
C800	Water Service Pipe (Type K, Soft Copper Pipes)
C900	PVC Pipe Sizes 100 mm to 300 mm
C907	PVC Pressure Fittings for Water
D100	Welded Steel Tanks for Water Storage
E101	Vertical Turbine Pumps - Line Shaft and Submersible Types
Miscellaneous Documents	
World Health Organization (1993) Guidelines for Drinking Water Quality, 2nd Edition, Volume 1. Recommendations. Geneva, Switzerland	
<u>Standard Methods for the Examination of Water and Wastewater</u> , Mary Ann H. Franson, Editor, American Public Health Association, 19th Edition, 1995.	



**GENERAL PROJECT SPECIFICATION FOR
POTABLE WATER TREATMENT, STORAGE AND DISTRIBUTION (TEMPORARY)**

3.0 SYSTEM DESIGN

- 3.1 The components of the water storage and distribution system shall include, but not be limited to:
 - a. Water supply lines from source wells to storage tank.
 - b. Water storage tank.
 - c. Water treatment equipment to provide the level of treatment necessary to comply with World Health Organization (WHO) Guidelines for Drinking Water Quality, local regulations and the requirements of this specification. WHO Drinking Water quality standards are listed in Table 2.
 - d. Water distribution mains and branch service lines.
- 3.2 The water distribution system layout shall incorporate looped piping wherever possible. Valves shall be provided on all branch service lines and on the mains at intervals sufficient to minimize disruption of service to consumers in the event of maintenance shut downs or breaks in the mains.
- 3.3 The structural design of the mains must address live loads at all road crossings and other areas where heavy vehicles may cross them.
- 3.4 Potable water system flow and pressure requirements shall be as follows:
 - a. Community residents per capita consumption: 360 l/d (95 gpd)
 - b. Operating pressure range during peak hour demand: 350 to 550 kPag (50 to 80 psig)

4.0 WATER TREATMENT

- 4.1 Treatments such as chlorination, sedimentation, coagulation-flocculation, filtration, aeration and ion exchange process shall be provided by Contractor if necessary to maintain the minimum standards for maximum contaminant levels of inorganic compounds, organic compounds, organic pesticides and physical properties such as turbidity, color, total dissolved solids and odor as specified in this specification, local regulations, and WHO Guidelines for Drinking Water Quality, whichever are more strict.
- 4.2 The treatment unit shall consist of a complete chlorination system in accordance with AWWA C653.



**GENERAL PROJECT SPECIFICATION FOR
POTABLE WATER TREATMENT, STORAGE AND DISTRIBUTION (TEMPORARY)**

- 4.3 Chlorine shall be injected at a point which will provide a minimum contact time of 20 minutes to produce a free chlorine residual of 0.5 mg/l.
- 4.4 Lab equipment for standard water analysis shall be supplied as required by the applicable AWWA standards. Methods of analysis shall be as in Standard Methods for the Examination of Water and Wastewater (1995).

5.0 TREATED WATER STORAGE TANK

- 5.1 Tankage shall be used to store water for human consumption.
- 5.2 Materials for tank construction shall be as follows:
 - a. Tank shall consist of steel plate construction with welded seams.
 - b. Tank padding shall consist of asphalt impregnated fiberglass or oxidized asphalts, fiberglass, and selected mineral or organic fillers bonded together to form sheets. Material shall be dry, firm, non-tacky, and resistant to mild acids and alkalines.

5.3 Installation Testing and Disinfection

Tank installation, testing and disinfection shall meet the following requirements:

- a. Erect tank on level foundation of appropriate design.
- b. Contractor shall water proof, if necessary, and thoroughly disinfect the ground storage tank and connecting lines with 50mg/l chlorine solution, in accordance with applicable Standard, before placing in operation. Valves in water lines being disinfected shall be opened and closed several times during the contact period. Following a contact period of 24 hours, heavily chlorinated water shall be flushed from the system with clean water. Disinfectant procedures require ESSO's approval.
- c. After refilling tank with potable water having chlorine content of not more than 1mg/l, take samples and submit for bacteriological testing. If samples are not free from coliform organisms repeat disinfection until tests comply with local regulations and WHO Guidelines for Drinking Water Quality.



**GENERAL PROJECT SPECIFICATION FOR
POTABLE WATER TREATMENT, STORAGE AND DISTRIBUTION (TEMPORARY)**

6.0 WATER PRESSURE TANK

6.1 General

Tank shall contain potable water and air for the purpose of maintaining adequate pressure within the distribution system.

6.2 Materials

Materials for tank construction shall be as follows:

- a. Tank shall consist of steel plate construction with welded seams.
- b. Tank shall be designed, fabricated and tested in compliance with ASME Boiler and Pressure Vessel Code, Section VIII, Division 1 (unfired pressure vessels). Design pressure shall be 689 kPag (100 psig) working pressure minimum.

6.3 Controls

Controls shall include combination pressure tank control for operating pumps and compressor to accurately and automatically maintain correct air to water ratio in tank. Each pressure sensor set point shall be easily adjustable.

6.4 Installation, Testing and Disinfection

Tank installation and testing shall meet the following requirements:

- a. Erect tank on level foundation of appropriate design.
- b. After installing valves and piping, and before field painting, subject valves and piping to hydrostatic pressure test in accordance with construction standards.
- c. Disinfect pressure tank and connecting lines with 50 mg/l chlorine solution in accordance with AWWA C652 and local requirements before placing in operation.
- d. Following contact period of not less than 24 hours, flush heavily chlorinated water from system with clean water until residual chlorine content is not greater than 1mg/l. Sample water and if samples are not free of coliform organisms, repeat disinfection until WHO Guidelines for Drinking Water Quality are satisfied.



**GENERAL PROJECT SPECIFICATION FOR
POTABLE WATER TREATMENT, STORAGE AND DISTRIBUTION (TEMPORARY)**

7.0 POTABLE/UTILITY WATER DISTRIBUTION PUMPS

- 7.1 The pumps shall be electric motor driven, automatically controlled by system demands and pressures or by remote control and be capable of satisfying the peak hour water demand. The pump system shall be pressure controlled based on the pressure downstream of the pumps. Check valves shall be provided downstream of the distribution pumps to prevent backflow.
- 7.2 A jockey pump shall be provided to maintain system pressure during low demand conditions with excess pressure relieved back into the storage reservoir.
- 7.3 The electrical power will be provided by Contractor.

8.0 POTABLE WATER DISTRIBUTION SYSTEM

8.1 General

Provisions for this Section apply to a temporary potable water distribution system. Contractor shall comply with pipe manufacturer installation instructions, manuals, and printed recommendations.

8.2 Piping Material and Installation

Piping material shall be as follows:

- 12 mm to 25 mm (½ inch to 1 inch) NPS: Type L copper, per ASTM B88
- 38 mm to 76 mm (1½ inch to 3 inch) NPS: SCH 80 CPVC per ASTM F441
- 100 mm (4 inch) and larger: STD, seamless, ASTM A53 GRB.

Galvanized steel pipe shall be protected against external corrosion. Cathodic protection shall be provided as necessary.

Underground installation and testing by Contractor shall be sanitary, workman like and safely done in accordance with local and AWWA standards:

- a. Keep pipe clean during laying operations by plugging or other approved method. Do not lay pipe when it is raining or when trench is muddy, soft, or contains standing water.



**GENERAL PROJECT SPECIFICATION FOR
POTABLE WATER TREATMENT, STORAGE AND DISTRIBUTION (TEMPORARY)**

- b. Do not lay water pipe closer than 3 meters (10 ft.) horizontally from sanitary sewer in parallel installations. Do not locate joints at cross-overs closer to sanitary sewer than 3 meters (10 ft.) from cross-over point. In either case, water pipe shall be above the elevation of adjacent sewer.

8.3 Pressure Testing

- a. Subject newly laid piping or valved section to hydrostatic pressure test.
- b. Carefully examine exposed pipe, joints, fittings, and/or valves during pressure test. Tighten or remake joints showing visible leakage. Replace and retest cracked or defective pipe, fittings and valves.

8.4 Disinfection

System disinfection shall be performed as follows:

- a. After testing, disinfect entire distribution system with 50mg/l chlorine solution in compliance with AWWA requirements. Isolate a maximum length of 300 meters (or 1000 ft.) of piping from the rest of the system for disinfection. Thoroughly flush lines before introducing chlorine solution. Disinfectant procedures shall require ESSO's approval.
- b. After a contact period of not less than 24 hours, flush system with clean water until residual chlorine content is not greater than 1 mg/l. Open and close all valves in lines being sterilized several times during contact period.
- c. Collect samples for bacteriological analysis to check efficiency of disinfection procedures. Take minimum on one sample for each 300 meters (or 1000 ft.) of completed water main. Repeat disinfection process and sample collection if tests show that contamination persists.

9.0 VALVES

9.1 Distribution Valves

In-ground valves shall be located in a valve box accessible to the operator for operation and maintenance.

9.2 Pressure Reducing Valves

Pressure reducing valves shall maintain a constant downstream pressure regardless of varying inlet pressure.



GENERAL PROJECT SPECIFICATION FOR
POTABLE WATER TREATMENT, STORAGE AND DISTRIBUTION (TEMPORARY)

TABLE 2

World Health Organization Guidelines for Drinking Water Quality		
Parameters	Design Standard	
Turbidity	5 NTU	Note - (a) (b)
Color	15 time Color units	Note - (b)
Odor	Inoffensive odor, 3 T.O.N. (d)	Note - (b)
pH	6.5 - 8.5	
Chlorines	5 mg/L, 0.6 - 1 mg/L	Note - (b)
Monochloramine	3 mg/L	
Total Dissolved Solids	1000 mg/L	Note - (b)
Total Coliform	0 per 100 ml	Note - (c)
Hydrogen Sulfide (H ₂ S)	0.05 mg/L	Note - (b)
		-
Inorganics		
Aluminum (Al Total)	0.2 mg/L	Note - (b)
Ammonium (NH ₄)	1.5 mg/L	Note - (b)
Antimony (Sb)	0.005 mg/L	
Arsenic (As)	0.01 mg/L	
Barium (Ba)	0.7 mg/L	
Boron (B)	0.3 mg/L	
Cadmium (Cd)	0.003 mg/L	
Chlorides (Cl)	250 mg/L	Note - (b)
Chromium (total)	0.05 mg/L	
Copper (Cu)	2 mg/L, 1 mg/L	Note - (b)
Cyanides (CN)	0.07 mg/L	
Fluoride (F)	1.5 mg/L	
Iron (Fe)	0.3 mg/L	Note - (b)
Lead (Pb)	0.01 mg/L	
Manganese (Mn)	0.5 mg/L, 0.1 mg/L	Note - (b)
Mercury (Hg)	0.001 mg/L	
Molybdenum (Mo)	0.07 mg/L	
Nickel (Ni)	0.2 mg/L	
Nitrates (NO ₃)	50 mg/L	
Nitrites (NO ₂)	3 mg/L	
Selenium	0.01 mg/L	
Sodium (Na)	200 mg/L	Note - (b)
Sulphates (SO ₄)	250 mg/L	Note - (b)
Zinc (Zn)	5 mg/L, 3 mg/L	Note - (b)
Aromatic Compounds		
Benzene	0.01 mg/L	
Ethylbenzene	0.3 mg/L, 2-200 µg/L	Note - (b)
Toluene	0.7 mg/L, 24-170 µg/L	Note - (b)
Xylene	0.5 mg/L, 20-1800 µg/L	Note - (b)
Styrene	20 µg/L, 4-2600 µg/L	Note - (b)
Benzo[a]pyrene	0.7 µg/L	
Chlorinated Alkanes		



GENERAL PROJECT SPECIFICATION FOR
POTABLE WATER TREATMENT, STORAGE AND DISTRIBUTION (TEMPORARY)

TABLE 2

World Health Organization Guidelines for Drinking Water Quality		
Parameters	Design Standard	
Carbon Tetrachloride	2 µg/L	
Dichloromethane	20 µg/L	
1,2 - Dichloroethane	30 µg/L	
1,1,1 - Trichloroethane	2000 µg/L	
Chlorinated Ethenes		
Vinyl Chloride	5 µg/L	
1,1 - Dichloroethene	30 µg/L	
1,2 - Dichloroethene	50 µg/L	
Trichloroethene	70 µg/L	
Tetrachloroethane	40 µg/L	
Chlorinated Benzenes		
Monochlorobenzene	300 µg/L, 10 - 120 µg/L	Note - (b)
1,2 - Dichlorobenzene	1000 µg/L, 1 -10 µg/L	Note - (b)
1,4 - Dichlorobenzene	300 µg/L, 0.3 - 30 µg/L	Note - (b)
Trichlorobenzenes (Total)	20 µg/L, 5 - 50 µg/L	Note - (b)
Disinfectant By-Products		
Bromate	25 µg/L	
Chlorite	200 µg/L	
2-Chlorophenol	0.1 - 10 µg/L	Note - (b)
2,4-Dichlorophenol	0.3-40 µg/L	Note - (b)
2,4,6 - Trichlorophenol	200 µg/L, 2-300 µg/L	Note - (b)
Formaldehyde	900 µg/L	
Bromoform	100 µg/L	
Dibromochloromethane	100 µg/L	
Bromodichloromethane	60 µg/L	
Chloroform	200 µg/L	
Dichloroacetic Acid	50 µg/L	
Trichloroacetic Acid	100 µg/L	
Chloral Hydrate (Trichloroacetaldehyde)	10 µg/L	
Pesticides		
Alachlor	20 µg/L	
Aldicarb	10 µg/L	
Aldrin/Dieldrin	0.03 µg/L	
Atrazine	2 µg/L	
Bentazone	30 µg/L	
Carbofuran	5 µg/L	
Chlordane	0.2 µg/L	
Chlorotoluron	30 µg/L	
DDT	2 µg/L	



GENERAL PROJECT SPECIFICATION FOR
POTABLE WATER TREATMENT, STORAGE AND DISTRIBUTION (TEMPORARY)

TABLE 2

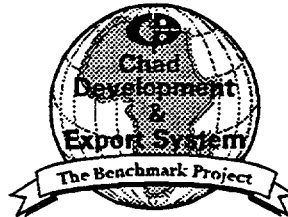
World Health Organization Guidelines for Drinking Water Quality	
Parameters	Design Standard
1,2-Dibromo-3-Chloropropane	1 µg/L
2,4-D	30 µg/L
1,2-Dichloropropane	20 µg/L
1,3-Dichloropropene	20 µg/L
Heptachlor and Heptachlor	0.03 µg/L
Hexachlorobenzene	1 µg/L
Isoproturon	9 µg/L
Lindane	2 µg/L
MCPA	2 µg/L
Methoxychlor	20 µg/L
Metolachlor	10 µg/L
Molinate	6 µg/L
Pendimethalin	20 µg/L
Pentachlorophenol	9 µg/L
Permethrin	20 µg/L
Propanil	20 µg/L
Pyridate	100 µg/L
Simazine	2 µg/L
Trifluralin	20 µg/L
Chlorophenoxy Herbicides Other than 2,4-D and MCPA 2,4-DB	90 µg/L
Dichlorprop	100 µg/L
Fenoprop	9 µg/L
Mecoprop	10 µg/L
2,4,5-T	9 µg/L
Miscellaneous	
Di(2-ethylhexyl)adipate	80 µg/L
Di(2-ethylhexyl)phthalate	8 µg/L
Acrylamide	0.5 µg/L
Epichlorohydrin	0.4 µg/L
Hexachlorobutadiene	0.6 µg/L
Edetic Acid (EDTA)	200 µg/L
Nitrilotriacetic Acid	200 µg/L
Tributyltin Oxides	2 µg/L

- Notes:
- a. NTU = Nephelometric Turbidity Units.
 - b. The range given (or second value listed) shows preferred aesthetically-based values.
 - c. No more than 5% of the samples per month may be positive. If less than 90 samples, no more than one can be positive.
 - d. Threshold Odor Number.

ESSO EXPLORATION & PRODUCTION CHAD INC.



CHAD DEVELOPMENT PROJECT



GENERAL PROJECT SPECIFICATION FOR PACKAGED SEWAGE TREATMENT SYSTEM (TEMPORARY)

GPS-004

Rev. No.	Date	No. of Pages	Prepared By	Reviewed By	Approved By	Revision Details
0	19 Nov 96	7	EHW/CKO	CKO	DJS	Issued for Proposals
1	30 Oct 97	7	MEF	PRS	DJS	Issued for EMP



GENERAL PROJECT SPECIFICATION FOR
PACKAGED SEWAGE TREATMENT SYSTEM (TEMPORARY)

TABLE OF CONTENTS

LIST OF TABLES 2

1.0 SCOPE 3

2.0 DESIGN 3

3.0 ELECTRICAL SYSTEM..... 4

4.0 MECHANICAL 4

5.0 PIPING 5

6.0 INSTRUMENTATION 5

7.0 UNIT PROCESSES 5

8.0 UNIT PROCESS SPECIFICATIONS 6

9.0 NOISE..... 7

10.0 START-UP AND OPERATING INSTRUCTIONS 7

11.0 GUARANTEE 8

LIST OF TABLES

TABLE 1 WORLD BANK LIQUID EFFLUENT CRITERIA..... 3



**GENERAL PROJECT SPECIFICATION FOR
PACKAGED SEWAGE TREATMENT SYSTEM (TEMPORARY)**

1.0 SCOPE

This Specification covers the functional requirements of a factory built, skid mounted, transportable, wastewater treatment unit(s) which will be used for the treatment of sanitary waste during the Work.

2.0. DESIGN

2.1 Effluent shall meet World Bank effluent guidelines for onshore oil and gas development. Table 1 highlights key World Bank effluent criteria.

Table 1

World Bank Liquid Effluent Criteria⁽¹⁾

Parameter	Maximum Levels
pH	6-9
BOD ₅	50 mg/L
Oil and Grease	20 mg/L
Heavy Metals, Total (except Barium)	10 mg/L
Phenolic Compounds	100 mg/L
Total Suspended Solids	50 mg/L
Coliform Bacteria	400 MPN/100 mL ⁽²⁾ (MPN - Most Probable Number)
Temperature - at the edge of the mixing zone	Max. 5° C above ambient temperature of receiving waters - Max. 3° C if receiving waters > 28° C.

Source: The World Bank Environment, Health and Safety, Guidelines, Onshore Oil and Gas Development (World Bank, 1995)

(1) Maximum daily discharge limits

(2) Average monthly concentration (i.e., 30 consecutive days of sampling)

2.2 Skid mounted components may be designed for modular assembly and shall be shipped complete with all equipment specified herein.

2.3 Major equipment shall be of proven design with a minimum of 2 years of successful operation in equal to or more severe than design operating conditions.



**GENERAL PROJECT SPECIFICATION FOR
PACKAGED SEWAGE TREATMENT SYSTEM (TEMPORARY)**

- 2.4 The treatment system shall be hydrostatically tested per governing code.
- 2.5 The treatment system shall be suitable for outdoor installation operation in a tropical climate.
- 2.6 The system shall include provisions for ensuring that effluent criteria are met during periods of system start-up and upsets.
- 2.7 Discharge will be to perennial surface waters, or to an absorption/evaporation system and will be performed in a manner that avoids soil erosion.

3.0 ELECTRICAL SYSTEM

The treatment system shall be completely prewired at the supplier's factory and shall be in accordance with International Electrotechnical Committee (IEC) Standards. Electrical enclosures shall be IP66.

4.0 MECHANICAL

- 4.1 Pumps shall be suitable for use in domestic wastewater application. Selection of the pump shall be based on its intended service.
- 4.2 The motors shall be designed per IEC standards.
- 4.3 Vessels shall be sized for the volume or holding time required for the proper operation of the system. Materials shall be compatible with sanitary sewage. Vessels shall be designed and constructed to conform with API 650.
- 4.4 Supplier's standard materials are acceptable provided they are consistent with standards accepted and used by the industry.
- 4.5 Torque ratings for the drives shall be based on standard design criteria accepted and used in the gear industry.
- 4.6 Machinery shall operate under all conditions without excessive vibration.
- 4.7 All grease fittings, oil fills, and drain points should be extended for easy access and service from walkways or operating platforms without raising floor plates.



GENERAL PROJECT SPECIFICATION FOR
PACKAGED SEWAGE TREATMENT SYSTEM (TEMPORARY)

5.0 PIPING

- 5.1 Piping shall be arranged in a way that prevents formation of liquid pockets or vapor traps. Block valves shall be provided to isolate principal skid termination points for inspection and maintenance. Butterfly valves shall not be used where positive shut-off is required. Piping and fittings shall be located in the confines of the skid and supported in such a way as to avoid unacceptable vibration, stresses or loads on equipment. Sufficient 19 mm (3/4 inch) vents and drains with corrosion resistant plugs shall be provided for hydrostatic testing and purging prior to start-up. Sampling ports between processes and at the effluent discharge should be provided.
- 5.2 Piping shall be per supplier's standard practice provided that it meets the conditions of 5.1, and provided that it is consistent with standards accepted and used by the industry.

6.0 INSTRUMENTATION

Vendor shall provide all necessary instrumentation for operation and testing of the system. All instrumentation and associated junction boxes shall be rated for IP66. The system shall have an overload alarm and control system.

7.0 UNIT PROCESSES

The unit processes shall consist of, but not be limited to:

- A coarse screen
- A comminutor/grinder
- Biological activated sludge, suspended growth, complete mix unit process, with contact stabilization or extended aeration
- Settling basin
- Sludge wasting system
- Chlorine contactor



GENERAL PROJECT SPECIFICATION FOR
PACKAGED SEWAGE TREATMENT SYSTEM (TEMPORARY)

8.0 UNIT PROCESS SPECIFICATIONS

8.1 Biological Treatment Unit

The biological treatment unit shall be an activated sludge, suspended growth process with the following design basis:

- The wastewater consists of liquid sanitary waste originating from the kitchen sinks, lavatories, showers, urinals and toilets.
- Flow shall be based on 360 liters (95 gallons) of wastewater generated per person, per day, assigned to the camp.
- The design shall be based on a mean cell residence time of not less than 5 days.
- Mixed liquid volatile suspended solids (MLVSS) are 1500 mg/l and mixed liquor suspended solids (MLSS) are 1600 mg/l.
- Influent BOD₅ shall be 300 mg/l (30 day avg.).
- Minimum air requirements are 1.1 Kg air/Kg BOD₅ removed. Average dissolved oxygen (DO) concentration of 2.0 mg/l shall be maintained.

The air distribution system shall be designed to evenly distribute air over the entire length of the aeration tank. Each assembly shall be designed and installed so as to be removable for cleaning without disturbing the operation of the plant.

8.2 Secondary Clarification

The Clarifier/Thickener shall be Supplier's standard design provided that it is consistent with standards accepted and used by the industry. The Clarifier/Thickener shall be fabricated, assembled, and tested at the supplier's factory to the maximum extent feasible. The system shall be complete with all structural supports, controls, instrumentation, piping, wiring, and components mounted.

Equipment and piping shall be arranged so that when installed, all external and internal components requiring manipulation, observation, and maintenance shall be readily accessible and safe to operating and maintenance personnel.

The secondary clarifier shall be based on the following design criteria:

- Overflow rate shall not exceed 24 m³/m²-d
- Minimum tank depth shall be 3m. Plan dimensions of the tank shall be minimized.



**GENERAL PROJECT SPECIFICATION FOR
PACKAGED SEWAGE TREATMENT SYSTEM (TEMPORARY)**

- Sludge Volume Index equals 150
- Solids loading rate shall not exceed 6 Kg/m²-hr

8.3 Sludge Wasting System

Supplier shall provide a method for wasting and dewatering excess sludge from the Clarifier underflow. Water from the dewatering process shall be returned to the biological treatment unit. Dewatered sludge will be landfilled or landspread into suitable soil or may be incinerated.

8.4 Return Activated Sludge (RAS)

Supplier shall provide a system for returning activated sludge from the Clarifier underflow to the biological treatment unit.

8.5 Chlorination

Supplier shall provide a disinfection tank with baffles to prevent short circuiting. The chlorine tank shall have sufficient capacity for the process condition. The chlorinator should dispense a predetermined and stable quantity of chlorine (preferably in tablet form). The chlorinator shall be designed to assure good contact with the water and to permit the free flow of water through the unit. Chlorine shall be injected at a rate of 2 to 5 mg/L at a point which will provide a minimum contact time of 30 minutes prior to discharge.

8.6 Walkways

The treatment plant shall be equipped with walkways, steps, ladders and handrails meeting governing standards.

9.0 NOISE

The system noise shall not exceed 85 dBA at 1 meter.

10.0 START-UP AND OPERATING INSTRUCTIONS

The supplier shall provide detailed operating and installation instructions. If appropriate, a trained representative will be provided to perform initial plant start-up and to assist Contractor in the operation and maintenance of the plant.



GENERAL PROJECT SPECIFICATION FOR
PACKAGED SEWAGE TREATMENT SYSTEM (TEMPORARY)

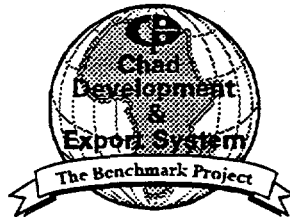
11.0 GUARANTEE

Contractor shall guarantee that the system provided meets the requirements of the World Bank effluent quality and functional performance of this specification. Contractor shall immediately correct any deficiencies in the equipment or its performance.

ESSO EXPLORATION & PRODUCTION CHAD INC.



CHAD DEVELOPMENT PROJECT



GENERAL PROJECT SPECIFICATION FOR WATER WELLS (TEMPORARY)

GPS-005

Rev. No.	Date	No. of Pages	Prepared By	Reviewed By	Approved By	Revision Details
0	19 Nov 96	5	FRE/CKO	CKO	DJS	Issued for Proposals
1	30 Oct 97	5	MEF	PRS	DJS	Issued for EMP



GENERAL PROJECT SPECIFICATION FOR
WATER WELLS (TEMPORARY)

TABLE OF CONTENTS

1.0 SCOPE 3

2.0 SUMMARY OF ADDITIONAL REQUIREMENTS 3

3.0 GROUND WATER SUPPLY AND WELLS 3

4.0 PUMP CONTROL 4

5.0 WELL PUMPS AND MOTORS 5

6.0 WATER WELL ABANDONMENT 5

LIST OF TABLES

TABLE 1 Reference Documents 3



**GENERAL PROJECT SPECIFICATION FOR
WATER WELLS (TEMPORARY)**

1.0 SCOPE

1.1 This specification covers the functional requirements for the design of temporary potable/utility water supply from ground water wells. These wells will be used to supply water for Contractor's needs during the Work. Upon site abandonment, wells will be closed per section 6.0 of this document unless otherwise directed by Esso.

2.0 SUMMARY OF ADDITIONAL REQUIREMENTS

2.1 Table 1 lists the standards which shall be used with this specification.

TABLE 1. Reference Documents

American Water Works Association (AWWA) Standards	
A100	Wells
C200	Steel Pipe (over 150 mm)
C508	Check Valves
C654	Disinfection of Wells
C900	PVC Pipes (100 mm to 300 mm)
E101	Vertical Turbine Pumps - Line Shaft and Submersible Types

3.0 GROUND WATER SUPPLY AND WELLS

- 3.1 Water supply source shall be from an underground aquifer. The following shall be taken into account during design:
- a. An approved hydrogeologist shall be retained to advise on well location, spacing, design and construction. The wells shall comply with AWWA A100.
 - b. Wells shall be located to avoid sources of surface or subsurface pollution and/or flooding.
 - c. Number of wells, size and depth of borings, gravel packs, screen sizes, well casings, sizes, number and capacity of multistage submersible pumps and electric motors, and size of discharge piping and other necessary components shall be designed to meet the required discharge pressures and flows.
 - d. Spacing of wells shall be such that the drawdown curves do not overlap for any adjacent wells.



**GENERAL PROJECT SPECIFICATION FOR
WATER WELLS (TEMPORARY)**

- e. Wells shall located and completed in a manner that prevents interference with public water supply wells.
- f. The well design shall ensure that the screen section is always fully submerged and that any fluctuations in the elevation of the water level in the saturated zone have been taken into account.
- g. Well seals shall be installed to prevent ground water contamination from the surface. The annular space between the casing and the drill hole shall be sealed using cementitious grout.
- h. Well casing material shall be selected to suit the site conditions.
- i. A stainless steel well screen shall be used. Well development shall be conducted to prevent intrusion of sand into the well bore (gravel pack may be needed). Pump testing, chemical and bacteriological testing of water samples shall be conducted.
- j. The well shall be cleaned to remove fine sand and debris and disinfected prior to use for potable water production. Potable water must comply with World Health Organization Standards as per GPS-003.
- k. A sampling point for each well shall be provided at a suitable location for taking samples for water quality monitoring.
- l. Either a piezometer, an electric resistance tape or a water level measuring air line shall be installed and calibrated to permit monitoring of ground water levels.
- m. On completion of the work on water wells and prior to design of water treatment, the following shall be reported:
 - Log of well drilling.
 - As-built drawings of wells, well pumps and other details.
 - Results of chemical and bacteriological tests on water samples.
 - Verification of water treatment requirements originally planned.

4.0 PUMP CONTROL

- 4.1 The system design shall incorporate the automatic operation of up to two well pumps. Each well pump shall start or stop as controlled by the storage water levels in the potable/utility water reservoir reaching pre-determined elevation set points or by the hydropneumatic tank pressure reaching pre-determined set points.



**GENERAL PROJECT SPECIFICATION FOR
WATER WELLS (TEMPORARY)**

4.2 Any additional well pumps shall be manually controlled.

5.0 WELL PUMPS AND MOTORS

5.1 Multi-stage submersible well pumps shall comply with AWWA E101.

5.2 Check valves shall be installed in pump discharge pipes.

5.3 Well pump motors shall comply with IEC and shall be stainless steel.

5.4 Power shall be provided to operate all elements of this system.

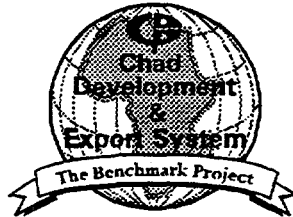
6.0 WATER WELL ABANDONMENT

To plug and abandon a water well, a cement plug shall be placed across and 10 m (32.8 feet) above the producing zone. A surface plug shall also be set from the surface to a depth of 20 m (65.6 feet). The pipe shall then be cut off one meter below grade and capped. The surface shall be restored to original contours.

ESSO EXPLORATION & PRODUCTION CHAD INC.



CHAD DEVELOPMENT PROJECT



GENERAL PROJECT SPECIFICATION FOR WASTE INCINERATOR (TEMPORARY)

GPS-006

Rev. No.	Date	No. of Pages	Prepared By	Reviewed By	Approved By	Revision Details
0	19 Nov 96	6	FRE	CKO	DJS	Issued for Proposals
1	30 Oct 97	6	MEF	PKS	DJS	Issued for EMP



GENERAL PROJECT SPECIFICATION FOR
WASTE INCINERATOR (TEMPORARY)

TABLE OF CONTENTS

1.0 SCOPE.....3

2.0 DOCUMENTATION.....3

3.0 DESIGN/CONSTRUCTION FEATURES.....4

4.0 MATERIALS.....6

5.0 INSPECTION AND TESTING6

6.0 INSTALLATION6

7.0 PERFORMANCE.....6

LIST OF TABLES

TABLE 1 WASTE CLASSIFICATION4



**GENERAL PROJECT SPECIFICATION FOR
WASTE INCINERATOR (TEMPORARY)**

1.0 SCOPE

- 1.1 This specification covers the functional requirements for a temporary Waste Incinerator system to be used by Contractor on the Work Site during the Work and removed upon completion of the Work.
- 1.2 The system will be located outdoors near an active Work Site. The system shall be capable of safely incinerating industrial waste, medical waste and municipal waste. The system shall provide (with proper maintenance) reliable operation on a periodic or continuous basis, as necessary.
- 1.3 The system shall be a complete package of the supplier's standard design suitable for the application as described in this specification. This package may include, but not necessarily be limited to, the following items:
 - Primary and secondary combustion chambers
 - Blowers, drivers, coupling, guards, ducts and equipment shelter
 - Rotary kiln, shakers, trays or containers for solids or sludges
 - Built-in stack
 - Refractory lining
 - Fuel handling equipment
 - Ash removal equipment
 - Burner management controls system
 - Pollution control equipment, as required
 - Waste loading system
 - Start-up and commissioning of the system

2.0 DOCUMENTATION

Contractor shall supply drawings and data in sufficient detail to describe all systems (including accessories), as well as operating and safety procedures and practices. This information shall be included in Contractor's Waste Management Plan required by Coordination Procedure Section 30 - Environmental Management.



**GENERAL PROJECT SPECIFICATION FOR
WASTE INCINERATOR (TEMPORARY)**

3.0 DESIGN/CONSTRUCTION FEATURES

3.1 Waste Classification

The classification of potential wastes to be incinerated shall be as per the following table.

**Table 1
Waste Classification**

Waste Type	Description	Typical Analysis	Moisture wt. %	Density kg/m ³	Heat Content kJ/kg
0	Dry industrial & commercial rubbish	Cardboard, dry paper, wooden pallets, floor sweepings, plastic bags	10	5	8500
1	General industrial commercial & domestic rubbish	Cardboard, paper, floor sweepings, up to 20% kitchen waste	25	10	6500
2	Refuse	Kitchen & domestic wastes, wet paper, floor sweepings, garden waste	50	15	4300
3	Pathological materials	Hospital dressing, disposable bedding, gowns, etc.	10 to 30	5 to 15	4500 to 8000
4	Pathological remains	Dead animals, human tissue, etc.	85	25 to 75	1000
5	Industrial wastes/oil sludge	Industrial process wastes	-	850 to 960	40,000
6	Semi-solid and solid wastes	Combustibles requiring hearth, retort, or grate burning equipment	-	Variable according to waste survey	Variable according to waste survey

Note: Waste classification based on Handbook of Industrial Waste Disposal, Tables 9-1 & 9-3.

3.2 Design Basis

The design basis, waste production rate, required incinerator capacity, and fuels supplied shall be specified by the Contractor to satisfy its needs.



**GENERAL PROJECT SPECIFICATION FOR
WASTE INCINERATOR (TEMPORARY)**

3.3 Refractories

- a. All refractory design and material shall be suitable for this service.
- b. The calculated cold face temperature of the exterior surface of the casing shall not be more than 82°C (180°F) based on a design maximum ambient temperature of 42°C (108 °F).

3.4 Waste Loading and Ash Removal Facilities

Contractor shall provide a system with related facilities to ensure the operation can be carried out efficiently and safely.

3.5 Burner and Ignition System

- a. Contractor shall provide only proven designs.
- b. Blowers and motors shall be provided with external lubrication.

3.6 Instrumentation and Controls

- a. Contractor shall have the incinerator supplier provide the control system completely coordinated, constructed, wired and checked out at the factory.
- b. All control devices and instruments and associated junction boxes shall be rated for IP66.

3.7 Noise Requirements

The incinerator contribution to sound level shall not exceed 85 dBA at 1 meter.

3.8 Emission Requirements

The air quality standards of the Environmental Impact Mitigation Specification shall be met.



**GENERAL PROJECT SPECIFICATION FOR
WASTE INCINERATOR (TEMPORARY)**

4.0 MATERIALS

The materials and components shall be the supplier's standards provided that those standards are consistent with industry practice, that they are suitable for the process and use in tropical and outdoor environments and have been proven successful in similar services.

5.0 INSPECTION AND TESTING

Contractor shall furnish ESSO with copies of all inspection and quality control documents.

6.0 INSTALLATION

Once approved by ESSO, Contractor shall install the incinerator system described in Section 4, above to meet waste management needs as approved in Contractor's Waste Management Plan. After conclusion of the Work, Contractor shall remove the system.

7.0 PERFORMANCE

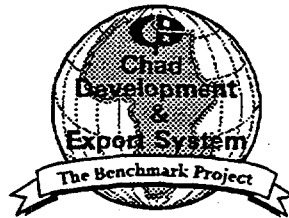
7.1 Contractor's system shall meet the requirements stated in this specification. It shall be the Contractor's responsibility to correct any deficiencies at a time agreeable to ESSO.

7.2 Contractor shall operate the incinerator system as needed until construction activities have been completed. Contractor shall incinerate its domestic, industrial and construction wastes as specified in Contractor's approved Waste Management Plan.

ESSO EXPLORATION & PRODUCTION CHAD INC.



CHAD DEVELOPMENT PROJECT



GENERAL PROJECT SPECIFICATION FOR NON-HAZARDOUS SOLID WASTE LANDFILL

GPS-007

Rev. No.	Date	No. of Pages	Prepared By	Reviewed By	Approved By	Revision Details
0	19 Nov 96	37	EHW/CKO	CKO	DJS	Issued for Proposals
1	30 Oct 97	37	MEF	<i>[Signature]</i>	DJS	Issued for EMP



GENERAL PROJECT SPECIFICATION FOR
NON-HAZARDOUS SOLID WASTE LANDFILL

TABLE OF CONTENTS

1.0 SCOPE..... 3
 2.0 SUMMARY OF ADDITIONAL REQUIREMENTS 3
 3.0 PURPOSE OF SOLID WASTE LANDFILL..... 4
 4.0 SITE SELECTION 4
 4.1 Initial Selection Criteria 4
 4.2 Final Selection 5
 5.0 DESIGN AND CONSTRUCTION CRITERIA..... 5
 5.1 Site Preparation and Access Roads 5
 5.2 Perimeter Dike and Outer Storm Water Ditch..... 10
 5.3 Landfill Area and Excavation..... 10
 5.4 Side Slope of Landfill and Berm Sides 11
 5.5 Composite Liner 11
 5.6 High Permeability Sand Layer for Drainage 13
 5.7 Leachate Collection System 13
 5.8 Run-On and Run-Off Control 14
 5.9 Preparation of Landfill Cells 15
 5.10 Gas Venting System..... 15
 5.11 Soils and Liner Quality Control Plan..... 16
 5.12 Soil and Liner Testing 16
 5.13 Soils and Liner Evaluation Report (SLER) and Flexible Membrane Liner
 Evaluation Report (FMLER) 19
 5.14 Groundwater Monitoring Systems..... 20
 5.15 Monitoring Wells..... 21
 6.0 OPERATING PROCEDURES..... 26
 6.1 Health And Safety 27
 6.2 Placement of Solid Waste Material..... 27
 6.3 Daily and Intermediate Cover 28
 6.4 Leachate Collection and Disposal..... 28
 6.5 Groundwater Monitoring..... 29
 6.6 Records..... 34
 7.0 CLOSURE REQUIREMENTS..... 35

LIST OF TABLES

Table 1. Additional Requirements..... 3
 Table 2. Cover Material Gradation 11
 Table 3. Depth of Cover Material..... 29
 Table 4. Sample Analysis Parameters 32



**GENERAL PROJECT SPECIFICATION FOR
NON-HAZARDOUS SOLID WASTE LANDFILL**

1.0 SCOPE

This functional specification includes the technical requirements for the design, construction and operation of a landfill site to be used for solid waste disposal. The construction includes earthwork, access roads, and installation of a landfill with a composite liner and leachate collection system and monitoring wells. The operation includes maintaining each landfill cell, collecting leachate and monitoring leachate and monitor-well water quality during the life of the facility and the closure period.

2.0 SUMMARY OF ADDITIONAL REQUIREMENTS

The publications listed in Table 1 are incorporated by reference into this specification. Except as modified by the requirements specified herein, work covered by this specification shall conform to the applicable provisions of these publications.

**Table 1
Specifications and Standards**

SPECIFICATIONS	
<u>CCS/ECS</u>	<u>Chad Cameroon Specifications/Esso Chad Specifications</u>
CCS 21-20-107 (Same as ECS 26-1-4)	Soil Erosion Mitigation Specification
CCS 21-20-108 (Same as ECS 26-1-5)	Environmental Impact Mitigation Specification
<u>GPS</u>	<u>General Project Specifications</u>
005	Water Wells (Temporary)
008	Project Safety Requirements
009	General Safeguards and Security Requirements
011	Waste Management
CODES AND STANDARDS	
<u>AASHTO</u>	<u>American Association of State Highway and Transportation Officials</u>
	Guide for Design of Pavement Structures
T88	Particle Size Analysis of Soils
T89	Determining the Liquid Limit of Soil
T90	Determining the Plastic Limit and Plasticity Index of Soils
<u>ASTM</u>	<u>American Society of Testing and Materials</u>
C136	Sieve or Screen Analysis of Fine and Coarse Aggregate
C478	Precast Reinforced Concrete Manhole Sections
D422	Test Method for Particle - Size Analysis of Soils
D1140	Test Method for Amount of Material in Soils Finer than the No. 200 (75- μ m.) Mesh



GENERAL PROJECT SPECIFICATION FOR
NON-HAZARDOUS SOLID WASTE LANDFILL

TABLE 1 (Cont'd.)

CODES AND STANDARDS	
<u>ASTM (Cont'd.)</u>	
D1557	Laboratory Compaction Characteristics of Soil Using Modified Effort (56,000 ft-lb/ft ³) (2700 kN-m/m ³)
D2216	Test Method for Laboratory Determination of Water (Moisture) Content of Soil and Rock
D3034	PSM Poly (Vinyl Chloride) PVC Sewer Pipe and Fittings (Perforated)
D4253	Maximum Index Density and Unit Weight of Soils Using a Vibratory Table
D4254	Minimum Index Density and Unit Weight of Soils and Calculation of Relative Density
D4318	Test Method for Liquid Limit, Plastic Limit, and Plasticity Index of Soils
D5084	Test Method for Measurement of Hydraulic Conductivity of Saturated Porous Materials Using a Flexible Wall Permeameter
D5093	Standard Test Method for Field Measurement of Infiltration Rate Using a Double-Ring Infiltrometer with a Sealed Inner Ring
<u>USCOE U. S. Army Corps of Engineers</u>	
EM 1110 2-1906	Corps of Engineers Manual
PUBLICATIONS	
<u>Standard Methods for the Examination of Water and Wastewater</u> , Mary Ann H. Franson, Editor, American Public Health Association, 19th Edition, 1995.	

3.0 PURPOSE OF SOLID WASTE LANDFILL

The solid waste landfill shall be designed, constructed and operated to accept only solid wastes approved in Contractor's Waste Management Plan in accordance with Section 30 of the Coordination Procedure - Environmental Management and GPS-011, Waste Management.

4.0 SITE SELECTION

4.1 Initial Selection Criteria

The criteria for the selection of landfills sites shall be as follows:

- a) Avoid residential areas, wetland, critical wildlife habitats, drainage courses and areas subject to seasonal flooding.
- b) Sites shall not be chosen within the 100 year flood plain of a stream, river or lake.
- c) The landfill shall not be located within 500 m (1640 ft.) of an airfield. This restriction is imposed to reduce potential bird hazards to aviation.



**GENERAL PROJECT SPECIFICATION FOR
NON-HAZARDOUS SOLID WASTE LANDFILL**

- d) The landfill must be at least 300 m (1,000 ft.) from any non-intermittent water course or other permanent water-body.
- e) The landfill shall not be constructed within 500 m (1640 ft.) radius of any water supply well.
- f) The landfill shall not be located within 60 m (200 ft.) of known geological fault areas.
- g) Avoid locations which have unstable subgrades and are likely to provide poor foundation conditions or are threatened by massive earth movements (e.g., landslides).
- h) The site shall have adequate room to accommodate the volume of wastes, berms, perimeter ditches, buffer zones, space for groundwater monitoring wells and access roads.
- i) On the basis of hydrogeological investigations, the site shall have a vertical separation between the seasonal high water table and the landfill bottom of greater than 1.5 m (5 ft.).
- j) The material that underlies the landfill shall have a hydraulic conductivity of not more than 10^{-6} cm/s.
- k) The site shall be located in an area where there will not be significant lateral transfer of mobilized contaminants in the groundwater. If significant groundwater flow rates are found, additional precautions shall be taken.
- l) The selected location shall be such that natural erosion or future land use will be unlikely to excavate or expose buried waste.

4.2 Final Selection

After preliminary selection of alternative landfill sites by Contractor, detailed and site specific geotechnical, hydrological, hydrogeological and environmental investigations shall be carried out to select the most appropriate site. Final site location requires ESSO approval.

5.0 DESIGN AND CONSTRUCTION CRITERIA

5.1 Site Preparation and Access Roads

- 5.1.1 The area inside the operational-zone fence shall be cleared. Clearing shall include the removal of all trees, bushes, and other vegetation, to within 150 mm (6 in.) above the natural grade. It shall also include the removal of dense growths of ground cover,



**GENERAL PROJECT SPECIFICATION FOR
NON-HAZARDOUS SOLID WASTE LANDFILL**

matted dead vegetation, and rubbish resting on natural grade. Clearing shall also include the specified removal of any existing structures, foundations, buried service piping and conduits.

- 5.1.2** Areas to be excavated or areas that will have facilities installed over them shall be grubbed. Grubbing shall include the excavation and complete removal of tree stumps, also the excavation and removal of all other plant life including root structures, plus rubbish, to a depth not less than 150 mm (6 in) below natural grade. Other minimum grubbing depth criteria supplemental to the 150 mm (6 in) minimum depth below natural grade requirements for grubbing are as follows for the following specific Work areas:
- Drainage ditches shall be grubbed to a depth not less than 300 mm (1 ft) beneath the finished sides and bottom.
 - Roadway areas shall be grubbed to a depth not less than 900 mm (3 ft) below finished grade but not less than 600 mm (2 ft) below natural grade.
 - Embankment slopes shall be grubbed to a depth not less than 300 mm (1 ft) beneath the finished slope.
 - Areas for piping between process unit area limits and ditches, and along roads, shall be grubbed to a depth not less than 600 mm (2 ft) below finished grade but not less than 150 mm (6 in) below natural grade.
- 5.1.3** All organic material from clearing and grubbing, including trees, stumps, roots, and brush shall be managed and disposed as specified in the Environmental Impact Mitigation specification.
- 5.1.4** Topsoil shall be stripped and stockpiled as indicated in the Soil Erosion Mitigation specification and the Environmental Impact Mitigation specification. Utilization of one or more alternate techniques (e.g. scarification, surface texturing, etc.) to control erosion and facilitate establishment of appropriate vegetation requires Esso approval.
- 5.1.5** Erosion control measures shall be implemented in accordance with the construction drawings and the Soil Erosion Mitigation specification. Mitigation measures specified in the Soil Erosion Mitigation specification shall be installed as soon as practical.



**GENERAL PROJECT SPECIFICATION FOR
NON-HAZARDOUS SOLID WASTE LANDFILL**

The faces of cut and fill slopes, and soil surfaces subject to rain, wind, and runoff disturbance shall be protected against erosion unless they are not subject to erosion due to the erosion-resistant character of the material.

5.1.6 An all-weather, laterite road shall be provided to the landfill site. As a minimum, the access road shall be designed and constructed in accordance with the following:

- a.) The geometry of the access road shall be as follows:
 - 1.) Max. gradient = 7%
 - 2.) Min. stopping distance = 85 m
 - 3.) Min. passing distance = 420 m
 - 4.) Max. super elevation = 0.06 m/m
 - 5.) Min. radius of curve = 130 m
 - 6.) Min. crest, k = 15 m
 - 7.) Min. sag, k = 20 m
 - 8.) Posted speed = 40 km/h
 - 9.) Design speed = 60 km/h
 - 10.) One lane 5 meters wide
- b.) The recommendations of "AASHTO Guide for Design of Pavement Structures" shall be applied to establish the pavement thickness, which will consist, as a minimum, of two 15 cm (6 inches) layers of compacted lateric material as a base and subbase course.
- c.) Ditches and culverts shall be designed to convey runoff from a ten year frequency storm with no erosion to the roadway or prepared surface. Culverts shall be designed for a minimum loading of HS20 in accordance with ASSHTO.
- d.) Roadway signs shall be in accordance with international standards and symbols using metric units. Signs shall also satisfy any local requirements and shall be submitted to ESSO for approval before supply and installation.
- e.) The roadway embankment, which is the earthwork below subgrade, shall be compacted to 90% of Modified Dry Density (MDD) in accordance with ASTM D1557. Water content shall



**GENERAL PROJECT SPECIFICATION FOR
NON-HAZARDOUS SOLID WASTE LANDFILL**

be adjusted to $\pm 3\%$ of Optimum Water Content (OWC) before compaction.

f.) Embankment fill material shall be free of organic material and roots and shall comply with the following requirements:

- 1.) Liquid limit not to exceed 60
- 2.) Plastic limit not to exceed 30
- 3.) CBR index at 4 days immersion to reach 10

g.) The subgrade is the top layer of the embankment which is below the subbase course. Where the design subgrade is in cut, the exposed surface of the natural ground shall be scarified to a minimum depth of 30 cm and recompacted in two layers to 95% of MDD. Water content shall be adjusted to $\pm 3\%$ of OWC before compaction.

h.) The subbase course shall be placed on finished subgrade, to the design thickness, but not more than 15 cm (6 inches) per lift. The base course shall be placed on finished subbase course, to design thickness, but not more than 15 cm (6 inches) per lift. The subbase and base course material shall be naturally occurring laterite, free of organic material and comply with the following requirements:

1. Liquidity limit not exceed 45
2. Plasticity index not to exceed 22
3. CBR index at 4 days immersion to reach 30
4. Coefficient of uniformity $D_{60}/D_{10} > 10$
5. Largest particle not to exceed 60 mm
6. Comply with gradation:

Sieve Opening (mm)	Percent Passing
60	100
40	95 - 100
31.5	90 - 100
20	75 - 100
10	60 - 90
5	36 - 75
2	25 - 55



**GENERAL PROJECT SPECIFICATION FOR
NON-HAZARDOUS SOLID WASTE LANDFILL**

0.5	18 - 40
0.08	8 - 30

The subbase and base course shall be compacted to 95% MDD.

- i. The standard test methods listed in Table 1 shall be used to determine material characteristics. The following minimum requirements shall apply. A copy of all test reports shall be submitted to ESSO for review.

Embankment fill

Modified Proctor to ASTM D1557	every 3000 m ³ or at changes of material
CBR at 90% MDD	every 5000 m ³ or at changes of material
In situ density and water content	every 500 m ³

Finished subgrade (in fill and in cut)

Modified Proctor to ASTM D1557	every 500 m
CBR at 95% MDD	every 1000 m
In situ density and water content	every 250 m
Level survey - along centerline and edges	

Subbase course

Borrow pit investigations - classification of soils to AASHTO T 88, T 89 and T 90	every 500 m ³
Modified Proctor to ASMT D1557	every 1000 m ³
CBR at 95% MDD	every 2000 m ³
In situ density and water content	every 250 m
Level survey - along centerline	

Base course

Borrow pit investigation - classification of soils to AASHTO T 88, T 89 and T 90	every 500 m ³
Modified Proctor to ASMT D 1557	every 1000 m ³
CBR at 95% MDD	every 2000 m ³
In situ density and water content	every 100 m
Level survey - along centerline and edges	



**GENERAL PROJECT SPECIFICATION FOR
NON-HAZARDOUS SOLID WASTE LANDFILL**

- j. Seeding, grassing, rip rap or other erosion control method shall be used along the roadside to prevent erosion of the draining ditches and damage to the access road.

5.1.7 The landfill site shall be accessible only when operation personnel are on duty. A chain link fence and gates shall be designed and constructed around the entire site in accordance with Coordination Procedure 25 - Safeguards and Security (S&S) at Work Sites. Gates shall include provisions for locking.

5.1.8 A minimum 30 m (100 ft.) buffer zone is required between the perimeter fence and the landfill.

5.2 Perimeter Dike and Outer Storm Water Ditch

A perimeter dike shall enclose the proposed landfill site. The perimeter dike shall consist of a 6 meter (20 ft.) wide buffer zone including a 3 meter (10 ft.) fire lane and a perimeter ditch to manage the storm water run-on. The finished elevation of the dike shall be set with due consideration to the thickness of compacted clay cap over each landfill cell after it has been completely filled and closed.

5.3 Landfill Area and Excavation

5.3.1 The total volume of wastes to be disposed during the life span of the landfill shall be based on the volume of acceptable solid waste generated by construction personnel and activities during construction as well as any volume requirements stated in the Design Basis Manual. Waste minimization shall be implemented, wherever feasible in order to keep the landfill area to a minimum.

5.3.2 All excavation material shall be processed and separated. Material meeting the grain size distribution indicated in Table 2 shall be retained and stockpiled for daily cover material. Those materials which are not needed for backfill or are unsuitable for daily cover shall be disposed of by the Contractor at a location approved by ESSO.



GENERAL PROJECT SPECIFICATION FOR
NON-HAZARDOUS SOLID WASTE LANDFILL

Table 2
Cover Material Gradation

SIEVE SIZE	PERCENT PASSING
12 mm (0.5 in.)	100
5 mm (No. 4)	90-100
2 mm (No. 10)	45-80
0.08 mm (No. 200)	8-98
Clay (0.002 mm)	8-50

5.3.3 All excavations shall be kept free of standing water at all times. Dewatering equipment such as pumps and hoses shall be provided and operated by Contractor to remove water from excavated areas.

5.4 Side Slope of Landfill and Berm Sides

Safe side slopes shall be constructed. A slope stability analysis shall be performed for both excavated side slopes and above-ground embankments to verify the structural integrity of a cut slope or berm. The design configuration shall be evaluated for its stability under all potential hydraulic and loading conditions.

5.5 Composite Liner

5.5.1 For purposes of this specification, "Composite Liner" means a system consisting of two components; the upper component must consist of a minimum 0.75 mm (30 mil) Flexible Membrane Liner (FML) and the lower component must consist of at least a 600 mm (2 ft) layer of compacted soil with a hydraulic conductivity of no more than 1×10^{-7} cm/sec (4×10^{-8} in/sec). FML components consisting of High Density Polyethylene (HDPE) shall be at least 1.5 mm (60mil) thick. The FML component must be installed in direct and uniform contact with the compacted soil component. The panel layout plan shall be made in advance so that travel of heavy equipment on the liner can be avoided. Vehicles shall not be



**GENERAL PROJECT SPECIFICATION FOR
NON-HAZARDOUS SOLID WASTE LANDFILL**

allowed on completed liners. Seaming of panels shall be completed in accordance with manufacturer's recommendations. At least 600 mm (2 ft.) of protective soil cover shall be placed above the composite liner.

- 5.5.2** If groundwater is encountered in disposal excavations, or in cases where excavations extend below the seasonal high-water table, material with a weight equivalent to 300 mm (1 ft.) of compacted clay liner for every 600 mm (2 ft.) of static water head shall be used as a basis for the construction of a liner between the deposited solid waste and the groundwater. The total thickness of this liner shall consist of no less than 900 mm (3 ft.) of soil with a permeability coefficient of no more than 1×10^{-7} cm/sec (3.94×10^{-8} in/sec), a liquid limit of no less than 30, a plasticity index of no less than 15, and a percent passing Number 200 sieve of no less than 30. Pressure release systems may be used to reduce the amount of liner support required.
- 5.5.3** The subgrade for placement of the clay portion of the composite liner shall be compacted in accordance with the following standards:
- Cohesive soils - 95 percent of the Modified Maximum Proctor Dry Density (MMPDD) in accordance with ASTM D1557.
 - Non-cohesive soils - 80 percent of relative density per ASTM D4253 and ASTM D4254.
- 5.5.4** Material for the clay portion of the composite liner shall be uniform with clods, rocks, and stones no larger than 25 mm (1 in.) and that total no more than 10% by weight. Disking and tilling of the material shall be performed as required to break up large clods. In all cases, soil clods shall be reduced to the smallest size necessary to achieve the coefficient of permeability reported by the testing laboratory and to destroy any macrostructure evidenced after the compaction of the clods under density-controlled conditions. Rock content shall not be a detriment to the integrity of the overlaying geomembrane.
- 5.5.5** The liner soil material shall be placed in lifts not exceeding 150 mm (6 in.). The surface of the previous lift shall be scarified before the next layer is added. Liner soil material shall not be compacted with a bulldozer or any track-mobilized equipment unless it is used to



**GENERAL PROJECT SPECIFICATION FOR
NON-HAZARDOUS SOLID WASTE LANDFILL**

pull a pad-footed or prong-footed roller. Each new lift shall be fully compacted to the previous lift to form a monolithic unit. The liner soil material shall be compacted to 97% of the MMPDD according to ASTM D1557.

- 5.5.6** Unless alternate construction procedures are approved in writing by ESSO, all constructed liners shall be keyed into an underlying formation of sufficient strength to ensure stability of the constructed lining.

5.6 High Permeability Sand Layer for Drainage

A highly permeable sand layer shall be placed over the composite liner. The thickness of the layer shall be such that it provides a maximum of 300 mm (12 in.) of leachate head above the liner. The sand drainage layer shall have a minimum slope of 2%.

This drainage layer serves two functions:

- Drain the leachate away from the underside of the waste.
- Protect the composite liner.

5.7 Leachate Collection System

5.7.1 The leachate collection system shall be designed to maintain less than 300 mm (12 in.) depth of leachate or "head" above the liner during the operating life of the landfill and through the closure and post closure periods.

5.7.2 The leachate collection and removal systems shall be:

- constructed of materials that are chemically resistant to the leachate expected to be generated,
- built of sufficient strength and thickness to prevent collapse under the pressures exerted by overlaying wastes, waste cover materials, and by any equipment at the landfill, and
- designed and operated to function through the scheduled closure period of the solid waste landfill.

5.7.3 The leachate collection system shall consist of a number of perforated pipes (as per ASTM D3034, if the criteria of 5.7.2 are



**GENERAL PROJECT SPECIFICATION FOR
NON-HAZARDOUS SOLID WASTE LANDFILL**

satisfied), with protective filter wrapping material, laid into the sand drainage layer.

- 5.7.4** The leachate collection system shall be designed and installed with the following characteristics:
- a) A trench shall be provided for the perforated pipes with 150 mm (6 in.) depth of cover of sand over the pipe.
 - b) The drain pipes shall have not less than 2% slope.
 - c) Size and horizontal spacing of the drain pipes shall be sufficient to control leachate levels to within the limits specified above.
 - d) The perforated pipe shall be wrapped in a woven polyethylene fabric such as Nicolon #66339, manufactured by Nicolon B.V., or equal as approved by ESSO.
 - e) Leachate collection lines that penetrate the liner shall have an antiseep collar. A minimum of 1.5 m (4.92 ft) of compacted clay shall be placed around the collar in all directions.
 - f) Pipe materials shall be clean and free of defects when placed in trench. Contractor shall not allow heavy equipment to travel over the newly installed leachate pipe during construction.
 - g) A collection sump shall be provided to capture leachates for treatment.
 - h) The collection sump shall be sized to collect the maximum volume of leachate expected during a leachate monitoring period specified in the "Operating Procedures" Section 6.0 of this specification.
 - i) The collection sump shall be a water-tight concrete structure with a water-tight, chemical resistant liner.

5.8 Run-On and Run-Off Control

- 5.8.1** Run-on control prevents rain water from flowing into the active portion of the landfill. Run-on control structures such as ditches, dikes and culverts shall be capable of preventing flow onto the active portion of the landfill during peak discharge from at least a 25 year storm.



**GENERAL PROJECT SPECIFICATION FOR
NON-HAZARDOUS SOLID WASTE LANDFILL**

5.8.2 Run-off control is the management of precipitation which falls on the landfill site so as to minimize the amount of rain water that gets in contact with waste or leachate. The run-off management system shall collect and control at least the water volume resulting from a 24 hour, 25 year storm. This shall be achieved in either of two ways:

- Keeping the active landfill cells small and by providing adequate grading so that run-off is controlled and diverted from the working area.
- Collecting and discharging run-off from the inactive portion of the landfill as storm water, thus reducing the overall leachate volume to be treated.

5.8.3 For erosion control, up-gradient and down-gradient ditches, berms, riprap, pavements or combinations thereof shall be used as necessary to achieve run-off and run-on control.

5.8.4 Collection and holding facilities (e.g. sumps or basins) associated with run-on or run-off control system shall be emptied or otherwise managed expeditiously after storms to maintain design capacity of the system.

5.9 Preparation of Landfill Cells

One landfill cell shall be opened at a time. The bottom of the cell shall be sloped for drainage away from the waste material. A temporary berm of approximately 0.6 m to 0.9 m (2 ft. to 3 ft.) in width shall be installed for isolation from previous cells.

5.10 Gas Venting System

A minimum of one passive gas vent shall be provided per cell to prevent the build-up of gas pressure beneath the cover.



GENERAL PROJECT SPECIFICATION FOR
NON-HAZARDOUS SOLID WASTE LANDFILL

5.11 Soils and Liner Quality Control Plan

Before landfill construction begins, Contractor shall have an ESSO approved Soils and Liner Quality Control Plan (SLQCP). The SLQCP must be included in the Site Development Plan to provide operating personnel adequate procedural guidance for assuring continuous compliance with groundwater protection requirements. The plan shall specify construction methods employing good engineering practices for compaction of clay soils to form a liner as well as the installation and testing of an FML. Quality control testing and reporting shall also be discussed.

The SLQCP shall include the following information:

- Proposed dewatering plans, where applicable.
- Constructed liner details, where applicable shall be depicted on cross-sections of a typical trench showing the slope, widths, and thickness for compaction lifts. The amount of compaction shall be expressed as a percentage of a predetermined laboratory density.
- Soil and liner quality control testing procedures, including sampling frequency. All field sampling and testing, both during construction and after completion, shall be performed by Contractor acting in compliance with the provisions of local government regulations and project environmental and quality control standards.

5.12 Soil and Liner Testing

Soil liner quality control testing frequencies and procedures shall be in accordance with the following:

- 5.12.1 All field sampling and testing, both during construction and after completion of the lining, shall be performed by a qualified professional experienced in geotechnical engineering and/or engineering geology, or under his direct supervision.
- 5.12.2 All liners shall have continuous on-site inspection during construction by the Contractor.



**GENERAL PROJECT SPECIFICATION FOR
NON-HAZARDOUS SOLID WASTE LANDFILL**

- 5.12.3** Clay liner density shall be expressed as a percentage of a maximum dry density based on a compaction test. The clay liner, after compaction, shall be proven by soils laboratory testing to provide a coefficient of permeability of 1×10^{-7} cm/sec (3.94×10^{-8} in/sec) or less.
- 5.12.4** The SLQCP shall define the frequency of testing for coefficient of permeability, sieve analysis, Atterberg limits, density, moisture content and thickness verification. These frequencies shall be expressed in numbers of tests per specific area of liner per lift or specific thickness of liner, unless an alternate frequency is approved by ESSO.
- 5.12.5** Unless otherwise approved by ESSO, all soil tests performed on any in-situ or constructed soil liners shall be in accordance with the following standards:
- a) Laboratory permeability tests shall be run using tap water or 0.05N solution of CaSO_4 and not distilled water. All test data must be submitted on permeability tests regardless of test method used. At a minimum, the calculations of the last data set reported for each sample and the resultant coefficient of permeability shall be reported as supporting data. Tests shall be either constant head with back pressure (Appendix VII of EM 1110-2-1906; or ASTM D5084) or falling head (Appendix VII of EM 1110-2-1906).
 - b) Sieve analysis with +1,200, to -200 sieves (ASTM D422 or ASTM D1140, as applicable).
 - c) Atterberg limits (ASTM D4318).
 - d) Moisture-density relations (ASTM D1557).
 - e) Moisture content (ASTM D2216).
- 5.12.6** All soils used as constructed liners shall have the following minimum values verified by testing in a soils laboratory: plasticity index equal to or greater than 30; percent passing 200 mesh sieve (-200) equal to or greater than 30%; percent passing a 25mm (1 inch) screen equal to 100%; coefficient of permeability less than or equal to 1×10^{-7} cm/sec (3.94×10^{-8} in/sec).



**GENERAL PROJECT SPECIFICATION FOR
NON-HAZARDOUS SOLID WASTE LANDFILL**

- 5.12.7** Permeability tests for providing the suitability of soils to be used in constructing clay liners shall be performed in the laboratory using the procedures and guidance of 5.12.5. Field quality control must be provided by field density tests based on predetermined moisture-density compaction curves, Atterberg limits, and laboratory permeabilities of undisturbed field samples of compacted liner soils, unless an alternate plan is approved by ESSO.
- 5.12.8** Field permeability testing of in situ soils or constructed soil liners shall be in accordance with ASTM D5093 for those soil liners which are in the floor of the excavation and a suitable variation approved by ESSO for the sidewalls.
- 5.12.9** Soil and liner density shall be expressed as a percentage of the maximum dry density and at the corresponding optimum moisture content specified as appropriate by an engineer experienced in geotechnical engineering. These soils, after compaction, shall upon testing either in the laboratory or as a test pad in the field demonstrate a coefficient of permeability no greater than 1×10^{-7} cm/sec (3.94×10^{-8} in./sec).
- 5.12.10** All quality control testing of soil liners shall be performed during the construction of the liner. In no instance shall any quality control field or laboratory testing be undertaken after completion of liner construction, except for that testing which is required of the final constructed lift, confirmation of liner thickness, or cover material thickness.
- 5.12.11** All soil testing and evaluation of either in situ soil or constructed soil liners shall be complete prior to installing the leachate collection system.



GENERAL PROJECT SPECIFICATION FOR
NON-HAZARDOUS SOLID WASTE LANDFILL

5.13 Soils and Liner Evaluation Report (SLER) and Flexible Membrane Liner Evaluation Report (FMLER)

- 5.13.1** Prior to the disposal of solid waste in any trench, or on any area, excavation, or unprotected surface, a SLER and a FMLER shall be prepared by the Contractor and submitted to ESSO for approval. Each SLER shall be prepared in accordance with the approved SLQCP. Any deviation from an approved SLQCP shall have prior written approval from ESSO. The SLER and FMLER shall report and summarize the results of tests performed to satisfy the requirements of the SLQCP. Any deficiencies found and remedial actions taken to bring the liners into compliance shall be noted.
- 5.13.2** Markers shall be placed on site at the landfill facility so that all disposal areas for which a SLER has been submitted and approved by ESSO are readily determinable. Such markers are to provide site workers immediate knowledge at all times of the extent of approved disposal areas. These markers shall be located so that they are not destroyed during operations.
- 5.13.3** Contractor shall provide sufficient documentation to ESSO to assure that the potential for contamination of waters is minimized. If ESSO determines that the SLER is incomplete or that the test data provided are insufficient to support the evaluation conclusions, additional test data or other information may be required, and use of the trench or disposal area shall not be allowed until such additional data are received, reviewed, and approved. Each SLER shall be signed by the Contractor.
- 5.13.4** The surface of a constructed soil liner should be covered with a layer of solid waste within a period of six months to mitigate the effects of surface erosion and rutting due to traffic. Liner surfaces not covered with waste within six months shall be checked by the Contractor, who shall then submit a letter report on its findings to ESSO. Any required repairs shall be performed promptly. A new SLER shall be submitted on the new construction for all liners that need repair due to damage.



GENERAL PROJECT SPECIFICATION FOR
NON-HAZARDOUS SOLID WASTE LANDFILL

5.14 Groundwater Monitoring Systems

A groundwater monitoring system shall be installed that consists of a sufficient number of monitoring wells, installed at appropriate locations and depths, to yield representative groundwater samples from the uppermost aquifer, defined as the geologic formation nearest the natural ground surface that is an aquifer. This includes lower aquifers that are hydraulically interconnected with this aquifer within the facility's property boundary.

The design of the groundwater monitoring system, including the number, spacing, and depths of monitoring wells or other sampling points, shall be certified by a qualified groundwater scientist.

The design shall be based on site specific technical information that must include a thorough characterization of:

- aquifer thickness;
- groundwater flow rate;
- groundwater flow direction including seasonal and temporal fluctuation in flow, effect of site construction and operations on groundwater flow direction and rates; and
- thickness, stratigraphy, lithology, and hydraulic characteristics of saturated and unsaturated geologic units, fill material overlying the uppermost aquifer, materials of the uppermost aquifer, and materials of the lower confining unit of the uppermost aquifer.

A geologic unit is any distinct or definable native rock or soil stratum.

Background wells shall be installed to allow determination of the quality of background groundwater that has not been affected by potential leakage from a unit. A determination of background quality may include sampling of wells that are not hydraulically upgradient of the waste management area if hydrogeologic conditions do not allow Contractor to determine which wells are hydraulically upgradient. Alternatively, sampling at other wells can be performed if it will provide a better indication of background groundwater quality than is possible from upgradient wells.



**GENERAL PROJECT SPECIFICATION FOR
NON-HAZARDOUS SOLID WASTE LANDFILL**

The downgradient monitoring system shall include monitoring wells installed to allow determination of the quality of groundwater passing the relevant point of compliance. The point of compliance is defined as the vertical surface located no more than 500 feet from the hydraulically downgradient limit of the waste management unit boundary, extending down through the uppermost aquifer underlying the landfill area, and located on land with access secured by ESSO. The final design of the groundwater monitoring system shall be submitted to ESSO for approval.

The downgradient monitoring system shall be installed to ensure the detection of groundwater contamination in the uppermost aquifer.

5.15 Monitoring Wells

Monitoring well installation and development must be supervised by a qualified geologist or engineer.

5.15.1 Drilling

Monitoring wells shall be drilled by a method that shall allow installation of the casing, screen, etc., and that shall not introduce contaminants into the borehole or casing. Drilling techniques used for boring shall take into account the materials to be drilled, depth to groundwater, total depth of the hole, adequate soil sampling, and other such factors that affect the selection of the drilling method. If any fluids are necessary in drilling or installation, then clean, treated water shall be used. Other fluids shall be approved in writing by ESSO before use. Chemical analysis of the water used shall be provided to ESSO with the monitoring well report.

The diameter of the boring shall be at least 100 mm (4 in.) larger than the diameter of the casing. When the boring is in hard rock, request to use a smaller annulus may be submitted to ESSO for approval.

During drilling of the monitoring well, a log of the boring shall be made by a qualified geologist or engineer.



**GENERAL PROJECT SPECIFICATION FOR
NON-HAZARDOUS SOLID WASTE LANDFILL**

5.15.2 Casing

The well casing shall be: 50 to 100 mm (2 to 4 in.) in diameter, NSF-certified PVC schedule 40 or 80 pipe, flush-thread, screw joint (no glue or solvents); polytetrafluoroethylene (PTFE, such as Teflon) tape or O-rings in the joints; no collar couplings. The top of the casing shall be at least 600 mm (2 ft.) above ground level.

Where high levels of volatile organic compounds (VOCs) or corrosive compounds are anticipated, stainless steel or PTFE casing and screen may be used, subject to approval by ESSO. 100 mm (4 in.) diameter casing is recommended because it allows larger volume samples to be obtained and provides easier access for development, pumps, and repairs.

The casing shall be cleaned and packaged at the place of manufacture; the packaging shall include a PVC wrapping on each section of casing to keep it from being contaminated prior to installation. The casing shall be free of ink, labels, or other markings. The casing (and screen) shall be centered in the hole to allow installation of a good filter pack and annular seal, using appropriately placed centralizers. The top of the casing shall be protected by a threaded or slip-on top cap or by a sealing cap or screw-plug seal inserted into the top of the casing. The cap shall be vented to prevent buildup of methane or other gases.

5.15.3 Well Screen

The screen shall be compatible with the casing and shall be of the same material. The screen shall not involve the use of any glues or solvents for construction. A wire-wound screen is recommended to provide maximum inflow area. Field-cut slots are not permitted for a well screen. Filter cloth shall not be used. A blank-pipe sediment trap, typically 300 to 600 mm (1 to 2 ft.) shall be installed below the screen. A bottom cap shall be placed on the bottom of the sediment trap. The sediment trap shall not extend through the lower confining layer of the water-bearing zone being treated. Screen sterilization methods are the same as those for casing.



**GENERAL PROJECT SPECIFICATION FOR
NON-HAZARDOUS SOLID WASTE LANDFILL**

Selection of the size of the screen opening should be performed by a person experienced with such work and shall include consideration of the distribution of particle sizes both in the water-bearing zone and in the filter pack surrounding the screen. The screen opening shall not be larger than the smallest fraction of the filter pack.

5.15.4 Filter Pack

The filter pack, placed between the screen and the well bore, shall consist of pre-packaged, inert, clean, silica sand or glass beads; it shall extend from 30 cm to 120 cm (1 ft. to 4 ft.) above the top of the screen. Open stockpile sources of sand or gravel are not permitted. The filter pack usually has a 30% finer grain size that is about 4 to 10 times larger than the 30% finer grain size of the water-bearing zone; the filter pack shall have a uniformity coefficient less than 2.5. The filter pack shall be placed with a tremie pipe to ensure that the material completely surrounds the screen and casing without bridging. The tremie pipe shall be cleaned prior to installing the first well and before each subsequent well.

5.15.5 Seals

The annular seal shall be placed on top of the filter pack and shall be at least 600 mm (2 ft.) thick. It shall be placed in the zone of saturation to maintain hydration. The seal shall be composed of, in order of preference, coarse-grain sodium bentonite, coarse-grit sodium bentonite, or bentonite grout.

Special care shall be taken to ensure that fine material or grout does not plug the underlying filter pack. Placement of a few inches of pre-packaged clean fire sand on top of the filter pack shall be used to prevent migration of the annular seal material into the filter pack. The seal shall be placed on top of the filter pack with a clean tremie pipe to ensure good distribution and shall be tamped with a clean rod to determine that the seal is thick enough. The bentonite shall be hydrated with clean water prior to any further activities on



**GENERAL PROJECT SPECIFICATION FOR
NON-HAZARDOUS SOLID WASTE LANDFILL**

the well and left to stand until hydration is complete (8 to 12 hours, depending on the grain size of the bentonite). If a bentonite-grout (without cement) casing seal is used in the well bore, then it may replace the annular seal.

A casing seal shall be placed on top of the annular seal to prevent fluids and contaminants from entering the borehole from the surface. The casing seal shall consist of a commercial bentonite grout or a cement-bentonite mixture. Drilling spoil, cutting, or other native materials are not permitted for use as a casing seal. Quick-setting cements are not permitted for use because contaminants may leach from them into the groundwater. The top of the casing seal shall be between 1500 mm and 600 mm (5 ft. and 2 ft.) from the surface.

5.15.6 Concrete Pad

Concrete, with a compressive strength of 25 MPa (3625 psi), shall be placed from the top of the casing seal (600 to 1500 mm (2 to 5 ft.) below the surface) continuously to the top of the ground to form a pad at the surface. This formed surface pad shall be at least 150 mm (6 in.) thick and not less than 1200 mm (4 ft.) square or 1500 mm (5 ft.) in diameter. The pad shall contain sufficient reinforcing steel to ensure its structural integrity in the event that soil support is lost. The top of the pad shall slope away from the well bore to the edges to prevent ponding of water around the casing or collar.

5.15.7 Protective Collar

A steel protective pipe collar shall be placed around the casing "stickup" to protect it from damage and unwanted entry. The collar shall be set at least 300 mm (1 ft.) into the surface pad during its construction and should extend at least 75 mm (3 in.) above the top of the well casing (and top cap, if present). The top of the collar shall have a lockable hinged top flap or cover. A sturdy lock shall be installed, maintained in working order, and kept locked when the well is not being bailed/purged or sampled. The well number or other designation shall be marked permanently on the collar including the total depth of the well and its elevation on the collar.



**GENERAL PROJECT SPECIFICATION FOR
NON-HAZARDOUS SOLID WASTE LANDFILL**

5.15.8 Protective Barrier

Where monitoring wells are likely to be damaged by moving equipment or are located in heavily traveled areas, a protective barrier shall be installed. A typical barrier is three or four 150 mm (6 in.) to 300 mm (12 in.) diameter pipes set in concrete just off the protective pad. The pipes can be joined by pipes welded between them, but consideration must be given to well access for sampling and other activities. Separation of such a pipe barrier from the pad means that the barrier can be damaged without risk to the pad and well. Other types of barriers may be approved by ESSO.

5.15.9 Unusual Conditions

Where monitoring wells are installed in unusual conditions, all aspects of the installation shall be submitted to ESSO in writing in advance for their consideration. Such aspects include, for example, the use of cellar-type enclosures for the top-well equipment or multiple completions in a single hole.

5.15.10 Well Development

After a monitoring well is installed, it shall be developed to remove artifacts of drilling (clay films, bentonite pellets in the casing, etc.) and to open the water-bearing zone for a maximum flow into the well. Development should continue until all of the water used or affected during drilling activities has been removed and field measurements of pH, specific conductance, and temperature have stabilized. Failure to develop a well properly may mean that it is not properly monitoring the water-bearing zone or may not yield adequate water for sampling even though the water-bearing zone is prolific.



GENERAL PROJECT SPECIFICATION FOR
NON-HAZARDOUS SOLID WASTE LANDFILL

5.15.11 Location and Elevation

Upon completion of a monitoring well, the location of the well and all appropriate elevations associated with the top-well equipment shall be surveyed. The elevation shall be surveyed to the nearest 0.003 m (0.01 ft.) above mean sea level (with year of the sea-level datum shown). The point on the well casing for which the elevation was determined shall be permanently marked on the casing. The location shall be given in terms of the latitude and longitude at least to the nearest tenth of the second or shall be accurately located with respect to the landfill grid system.

5.15.12 Reporting

Monitoring well installation and construction details shall be completed and submitted to ESSO within 30 days of well completion. A copy of the detailed geologic log of the boring, any particle size or other sample data from the well, and a site map drawn to scale showing the location of all monitoring wells shall be submitted to ESSO.

5.15.13 Damaged Wells

Any monitoring well that is damaged to the extent that it is no longer suitable for sampling shall be reported to ESSO who shall make a determination about whether to repair or replace the well.

5.15.14 Plugging and Abandonment

Any monitoring well that is no longer used shall be properly plugged and abandoned. No abandonment shall take place without prior authorization in writing by ESSO. Procedures for abandonment shall be as given in GPS-005 (Water Wells (Temporary)).

6.0 OPERATING PROCEDURES

Landfill operation shall consist of placing, spreading and compacting solid waste materials approved for landfill disposal in Contractor's Waste Management Plan in landfill cell trenches in uniform layers separated by layers of cover material. The



**GENERAL PROJECT SPECIFICATION FOR
NON-HAZARDOUS SOLID WASTE LANDFILL**

landfill site will be capped and closed when wastes are no longer received at the site.

6.1 Health and Safety

The disposal site shall be operated in such a manner as to protect the health and safety of personnel associated with the operation. Contractor shall instruct personnel as to standard procedures for maintaining safety in accordance with GPS-008 (Project Safety Requirements) and Section 22 of the Coordination Procedure - Project Safety Practices. In addition, the following measures shall be implemented:

- a) Personal safety devices and gear shall be provided by Contractor to facility personnel.
- b) Safety and warning devices shall be provided on all equipment used to spread and compact waste or cover material.
- c) Contractor shall take appropriate steps to prevent and control on site populations of disease vectors using proper compaction and daily cover procedures, and the use of other approved methods as needed.
- d) Litter and other windblown material shall be collected on a regular basis and returned to the active disposal area or working face as necessary to minimize unhealthy, unsafe, or unsightly conditions.
- e) The working surfaces of all equipment that come in contact with wastes shall be washed down on a regular basis. Wastewaters shall not be allowed to accumulate on site without proper treatment to prevent the creation of odors or an attraction to disease vectors.
- f) Contractor shall make provisions to extinguish any fires in wastes being delivered to the site or which occur at the working face or within equipment or personnel facilities.

6.2 Placement of Solid Waste Material

Waste materials shall be trucked to the landfill and placed in the landfill cell trenches. The waste shall be compacted on slopes less than 3:1 (H:V) in lifts of 0.6 m (2 ft.) or less by three to five passes of tracked equipment. Solid waste handling equipment shall on any operating day be capable of performing the following functions:

- Spreading the waste materials in an uncompacted layer with a maximum thickness of 60 cm (2 ft.) while confining it to the smallest practicable area,
- Compacting the spread waste material to the smallest practicable volume, and



GENERAL PROJECT SPECIFICATION FOR
NON-HAZARDOUS SOLID WASTE LANDFILL

- Placing, spreading and compacting the cover material over a waste layer by the end of the day's operation.

6.3 Daily and Intermediate Cover

Soil cover shall be placed to control insects, rodents, scavenging birds, blowing litter, flies, odors and to provide better access to the working face. The intent is to ensure that deposition of waste will not adversely affect the environment or public health.

A soil cover (minimum 150 mm (6 in.) thickness) shall be placed and compacted daily. Acceptable cover material shall meet the criteria given in Table 2.

An intermediate soil cover (minimum 300 mm (12 in.) thickness) shall be placed and compacted on areas which will not receive additional wastes for longer periods.

The cover material for each layer of waste shall be spread and compacted in accordance with Table 3.

Table 3.

Depth of Cover Material

TYPE OF COVER [Period of Site Inactivity (P)]	DAILY [P < 1 week]	INTERMEDIATE [week < P < 1 year]	FINAL [P > 1 year]
Compacted Thickness	150 mm (6 in.)	300 mm (1 ft.)	600 mm (2 ft.)

6.4 Leachate Collection and Disposal

The leachate sump shall be monitored by Contractor for level of accumulated liquid and leachate quality. The sump shall be monitored on a regular basis to ensure that overflowing of the sump does not occur. The leachate quality shall be monitored semi-annually. The leachate shall be extracted from the sump and disposed of by Contractor in its sewage treatment plant. If necessary, Contractor shall adjust leachate pH and treat to remove heavy metals and excess salts that would not be compatible with the sewage treatment design parameters and effluent quality before sending the leachate to its sewage treatment system.



**GENERAL PROJECT SPECIFICATION FOR
NON-HAZARDOUS SOLID WASTE LANDFILL**

The leachate collection system must be properly maintained on an annual basis (or more often, as necessary). The leachate lines shall be cleaned out by the Contractor and the sump pump inspected once a year.

6.5 Groundwater Monitoring

The groundwater monitoring program shall include consistent sampling and analysis procedures that are designed to ensure monitoring results that provide an accurate representation of groundwater quality at the background and downgradient wells.

Contractor shall notify ESSO promptly (within 1 day) in writing of changes in site construction or operation or changes in adjacent property that affect or are likely to affect the direction and rate of groundwater flow and the potential for detecting groundwater contamination from the solid waste landfill that may require the installation of additional monitoring wells or sampling points.

6.5.1 Groundwater Sampling and Analysis Plan

Contractor shall submit a groundwater sampling and analysis plan (GWSAP) to ESSO for review and approval prior to commencement of sampling and shall maintain a current copy in the operating record. The GWSAP shall:

- a) include procedures and techniques for sample collection, sample preservation and shipment, analytical procedures, chain-of-custody controls, quality assurance, and quality control;
- b) provide for measurement of groundwater elevations at each sampling point prior to bailing or purging. Measurement at an event shall be accomplished over a period of time short enough to avoid temporal variations in water levels. Sampling at each event shall proceed from the point with the highest water-level elevation to those with successively lower elevations unless contamination is known to be present, in which case wells not likely to be contaminated shall be sampled prior to those that are known to be contaminated unless an alternative procedure is approved by ESSO; and
- c) include sampling and analytical methods that are appropriate for groundwater sampling and that accurately measure



**GENERAL PROJECT SPECIFICATION FOR
NON-HAZARDOUS SOLID WASTE LANDFILL**

hazardous constituents and other monitoring parameters in groundwater samples. The number of samples to be collected to establish groundwater quality data shall be consistent with the appropriate statistical procedures for determination of evidence of contamination.

6.5.2 Groundwater Sampling and Analysis

Groundwater samples shall not be field-filtered prior to laboratory analysis unless in accordance with the ESSO approved groundwater sampling and analysis plan.

The sampling procedures shall be protective of human health and the environment and appropriate for generation of statistically significant data.

Contractor shall establish background groundwater quality in hydraulically upgradient wells or in background wells for each of the monitoring parameters or constituents required in the ground monitoring program for a solid waste landfill. Downgradient groundwater data shall not be adjusted by subtracting background groundwater data.

Contractor shall determine within 7 calendar days after completing sampling and analysis whether or not there is evidence of a statistically significant change from background values for each constituent required in the groundwater monitoring program for the solid waste landfill. In determining if there is evidence of a statistically significant change from background, Contractor shall compare the groundwater quality of each tested constituent at each monitoring well or other sampling points to the background value of that constituent.

6.5.3 Constituents to be Monitored

Compounds that groundwater samples shall be tested for include those listed in Table 4, at a minimum. ESSO may delete any of the constituents listed in Table 4 if it can be documented that the removed constituents are not reasonably expected to be in or derived from the waste contained in the landfill. Contractor may



**GENERAL PROJECT SPECIFICATION FOR
NON-HAZARDOUS SOLID WASTE LANDFILL**

also petition ESSO for removal of constituents from the list if it believes these conditions are met.

Parameters shall be tested using methods in Standard Methods for the Examination of Water and Wastewater (Mary Ann H. Franson, editor, American Public Health Association, 1995). Test results shall be certified by Contractor and the records of said tests kept as per Section 30 of the Coordination Procedure.

ESSO may establish an alternative list of inorganic indicator constituents in lieu of some or all of the heavy metals, if the alternative constituents provide a reliable indication of inorganic releases from the solid waste landfill to the groundwater.

ESSO may also add inorganic or organic constituents to those to be tested if they are reasonably expected to be in or derived from the waste contained in the unit or if they are likely to provide a useful indication of releases from the solid waste landfill to the groundwater.

**Table 4.
Sample Analysis Parameters**

	INORGANIC CONSTITUENTS	CAS RN ^{1,2}
1	Antimony	(Total)
2	Arsenic	(Total)
3	Barium	(Total)
4	Beryllium	(Total)
5	Cadmium	(Total)
6	Chromium	(Total)
7	Cobalt	(Total)
8	Copper	(Total)
9	Lead	(Total)
10	Mercury	(Total)
11	Nickel	(Total)
12	Selenium	(Total)
13	Silver	(Total)
14	Thallium	(Total)
15	Vanadium	(Total)
16	Zinc	(Total)
	ORGANIC CONSTITUENTS³	
17	Acetone	67-64-1
18	Acrylonitrile	107-13-1

ESSO EXPLORATION & PRODUCTION CHAD INC.



GENERAL PROJECT SPECIFICATION FOR
NON-HAZARDOUS SOLID WASTE LANDFILL

19	Benzene	71-43-2
20	Bromochloromethane	74-97-5
21	Bromodichloromethane	75-27-4
22	Bromoform (tribromomethane)	75-25-2
23	Carbon disulfide	75-15-0
24	Carbon tetrachloride	56-23-5
25	Chlorobenzene	108-90-7
26	Chloroethane (ethyl chloride)	75-00-3
27	Chloroform (trichloromethane)	67-66-3
28	Dibromochloromethane (chlorodibromomethane)	124-48-1
29	1,2-Dibromo-3-chloropropane (DBCP)	96-12-8
30	1,2-Dibromoethane (ethylene dibromide, EDB)	106-93-4
31	o-Dichlorobenzene (1,2-dichlorobenzene)	95-50-1
32	p-Dichlorobenzene (1,4-dichlorobenzene)	106-46-7
33	trans-1,4-Dichloro-2-butene	110-57-6
34	1,1-Dichloroethane (ethylidene chloride)	75-34-3
35	1,2-Dichloroethane (ethylene dichloride)	107-06-2
36	1,1-Dichloroethylene (1,1-dichloroethene, vinylidene chloride)	75-35-4
37	cis-1,2-Dichloroethylene (cis-1,2- dichloroethene)	156-59-2
38	trans-1,2-Dichloroethylene (trans-1,2- dichloroethene)	156-60-5
39	1,2-Dichloropropane (Propylene dichloride)	78-87-5
40	cis-1,3-Dichloropropane	10061-01-5
41	trans-1,3-Dichloropropene	10061-02-6
42	Ethylbenzene	100-41-4
43	2-Hexanone (methyl butyl ketone)	591-78-6
44	Methyl bromide (bromomethane)	74-83-9
45	Methyl chloride (chloromethane)	74-87-3
46	Methylene bromide (dibromomethane)	74-95-3
47	Methylene chloride (dichloromethane)	75-09-2
48	Methyl ethyl ketone (MEK, 2-butanone)	78-93-3
49	Methyl iodide (iodomethane)	74-88-4
50	4-Methyl-2-pentanone (methyl isobutyl ketone)	108-10-1
51	Styrene	100-42-5
52	1,1,1,2-Tetrachloroethane	630-20-6
53	1,1,2,2-Tetrachloroethane	79-34-5
54	Tetrachloroethylene (tetrachloroethene, perchloroethylene)	127-18-4
55	Toluene	108-88-3
56	1,1,1-Trichloroethane (methylchloroform)	71-55-6
57	1,1,2-Trichloroethane	79-00-5



**GENERAL PROJECT SPECIFICATION FOR
NON-HAZARDOUS SOLID WASTE LANDFILL**

58	Trichloroethylene (trichloroethene)	79-01-6
59	Trichlorofluoromethane (CFC-11)	75-69-4
60	1,2,3-Trichloropropane	96-18-4
61	Vinyl acetate	108-05-4
62	Vinyl chloride	75-01-4
63	Xylenes	1330-20-7

1. The Chemical Abstracts Service registry number (CAS RN).
2. Where "Total" is entered, all species in the groundwater that contain the element are included.
3. Common names of the VOCs are those widely used in government regulation, scientific publications, and commerce. Synonyms exist for many of them.

6.5.4 Monitoring Frequency

The monitoring frequency for all constituents shall be annually during the active life of the facility and the closure period.

A minimum of four statistically independent samples from each background and each downgradient well shall be collected and analyzed for the constituents. The independence of the four samples shall be achieved by bailing or purging at least one well volumes (or to dryness, if less) from each well before each of the four samples is collected.

ESSO may specify an appropriate alternative frequency for repeated sampling and analysis of the constituents. The alternative frequency shall be no less than annual and shall be based on factors such as lithology and hydraulic conductivity of the aquifer and unsaturated zone, groundwater flow rates, minimum distance of travel from waste to monitoring wells, and resource value of the uppermost aquifer.

6.5.5 Changes in Groundwater Quality

Not later than 60 days after each sampling event, Contractor shall notify ESSO in writing if there has been a statistically significant change from background of any tested constituent at any monitoring well.

If a statistically significant change from background of any tested constituent at any monitoring well has occurred, Contractor shall



GENERAL PROJECT SPECIFICATION FOR
NON-HAZARDOUS SOLID WASTE LANDFILL

immediately place a notice in the operating record describing the increase.

If a statistically significant change from background of any tested constituent at any monitoring well has occurred and Contractor has reasonable cause to think that a source other than the solid waste landfill caused the contamination or that the statistically significant change resulted from error in sampling, analysis, statistical evaluation, or natural variation in groundwater quality, then Contractor shall submit a report providing documentation to this effect. The report shall be prepared by a qualified groundwater scientist and submitted to ESSO for review and approval not later than 90 days after the sampling event.

6.6 Records

Contractor shall maintain disposal records covering at least the following:

- a) Major operational problems or difficulties.
- b) Qualitative and quantitative evaluations of the environmental impact of the disposal site including results of:
 - Leachate sampling and analysis;
 - Ground and surface water quality sampling and analysis upstream and downstream of the site;
 - Source of daily, intermediate, and final cover material;
 - Waste compaction;
 - Gas generation and gas control procedures (as appropriate);
 - Vector control efforts; and
 - Dust and litter control efforts.
- c) Quantitative measurements of the solid wastes handled, accomplished through routine or periodic utilization of scales and topographic surveys of the site.
- d) Description of amounts and types of solid waste materials received in each landfill cell identified by source of materials as per the database required by the Coordination Procedure Section 30 - Environmental Management. This database shall be turned over to ESSO at project completion.



GENERAL PROJECT SPECIFICATION FOR
NON-HAZARDOUS SOLID WASTE LANDFILL

7.0 CLOSURE REQUIREMENTS

Within 180 days of the last receipt of wastes for landfill, Contractor shall complete the installation of a final cover system for the landfill that is designed and constructed to minimize infiltration and erosion. The final cover system shall be composed of no less than 750 mm (2.5 ft.) of soil and consist of an infiltration layer overlain by an erosion layer as follows:

- The infiltration layer shall consist of a minimum of 450 mm (18 in.) of earthen material with a coefficient of permeability no greater than 1×10^{-5} cm/sec (3.94×10^{-6} in./sec) overlain by a synthetic membrane that has a permeability less than or equal to the permeability of the bottom liner system. The minimum thickness of the synthetic membrane shall be 0.5 mm (20 mils), or 1.5 mm (60 mils), in the case of HDPE, in order to ensure proper seaming of the synthetic membrane.
- The erosion layer shall consist of a minimum of 300 mm (12 in.) of earthen material that is capable of sustaining native plant growth and shall be seeded or sodded immediately following the application of the final cover in order to minimize erosion.

Contractor shall submit to ESSO for approval a written final closure plan that describes the steps necessary to close the landfill site. The final closure plan, at a minimum, shall include the following information:

- a description of the final cover design and methods and procedures to be used to install the cover;
- an estimate of the largest area of the landfill site ever requiring a final cover at any time during the active life of the landfill;
- an estimate of the maximum inventory of wastes ever on-site over the active life of the landfill and a summary of the types and amounts of waste contained in each landfill cell;
- a schedule for completing all activities necessary to satisfy the closure criteria; and



GENERAL PROJECT SPECIFICATION FOR
NON-HAZARDOUS SOLID WASTE LANDFILL

- a final contour map depicting the proposed final contours, establishing top slopes and side slopes, proposed surface drainage features, and protection of any 100-year flood plain.

No later than 45 days prior to the initiation of closure activities for the landfill site, Contractor shall provide written notification to ESSO of the intent to close the landfill site and place this notice of intent in the operating record.

Following receipt of the required final closure documents, ESSO shall acknowledge the termination of operation and closure of the facility or site and evaluate whether it is properly closed. Contractor shall correct any deficiencies identified by ESSO in its evaluation.

Quality control testing documentation is as follows:

- Contractor is responsible for placing and compacting clay soils for the final cover infiltration layer.
- Contractor shall test the 450 mm (18 in.) of compacted material for its coefficient of permeability at a frequency of no less than one test per surface acre of final cover.
- Permeability data shall be submitted to ESSO for approval.

ESSO EXPLORATION & PRODUCTION CHAD INC.



CHAD DEVELOPMENT PROJECT



GENERAL PROJECT SPECIFICATION FOR PROJECT SAFETY REQUIREMENTS

GPS-008

Rev. No.	Date	No. of Pages	Prepared By	Reviewed By	Approved By	Revision Details
0	19 Nov 96	40	CLO	PRS	DJS	Issued for Proposals
1	30 Oct 97	40	MEF	PRS	DJS	Issued for EMP



GENERAL PROJECT SPECIFICATION FOR
PROJECT SAFETY REQUIREMENTS

TABLE OF CONTENTS

1.0 GENERAL 4
2.0 CLOTHING REQUIREMENTS 7
3.0 PERSONAL PROTECTIVE EQUIPMENT 8
4.0 SIGNS, SIGNALS, BARRICADES, AND LIGHTS 9
5.0 RIGGING EQUIPMENT FOR MATERIAL HANDLING 10
6.0 HAND AND POWER TOOLS 10
7.0 COMPRESSED GASES 11
8.0 SCAFFOLDS 12
9.0 JOB SITE TRANSPORTATION RULES 13
10.0 CRANES, DERRICKS AND LIFTING EQUIPMENT 14
11.0 CRANE SPECIFICS 16
12.0 EQUIPMENT AND MOTOR VEHICLES, AND MARINE OPERATIONS 17
13.0 ELECTRICAL 18
14.0 LADDERS AND STAIRWAYS 19
15.0 FLOOR AND WALL OPENINGS AND STAIRWAYS 20
16.0 EXCAVATIONS AND TRENCHING 20
17.0 STEEL ERECTION 21
18.0 CONFINED AREAS OR SPACES 22
19.0 HOUSEKEEPING 23
20.0 CONTRACTOR RESPONSIBILITIES - MEDICAL SERVICES 25
21.0 MINOR CUTS, SCRATCHES, BRUISES, ETC. - FIRST AID 26
22.0 MEDICAL CASES NOT REQUIRING EVACUATION 26
23.0 MEDICAL CASES REQUIRING EVACUATION SERVICE 27
24.0 CONTRACTOR / SUB-CONTRACTOR DOCUMENTATION 28
25.0 REQUIRED ACCIDENT/INJURY INFORMATION 31
26.0 SAFETY RULES AND PROCEDURES 33
27.0 HAZARDOUS MATERIALS PROCESS AND/OR CHEMICALS 33
28.0 FIRE SUPPRESSION EQUIPMENT 34
29.0 SAFETY & PERSONNEL PROTECTIVE EQUIPMENT 34
30.0 WORK PERMIT REQUIREMENTS 35



**GENERAL PROJECT SPECIFICATION FOR
PROJECT SAFETY REQUIREMENTS**

31.0 EMERGENCY PROCEDURES..... 36
32.0 MEDICAL SERVICES..... 37
33.0 SAFETY INCENTIVE PROGRAMS 37
34.0 SAFETY MEETINGS 37
35.0 SUB-CONTRACTORS..... 37
36.0 DISCIPLINARY PROCEDURES 37
37.0 PROJECT SAFETY GOALS..... 38
38.0 PURPOSE STATEMENT..... 38
39.0 SAFETY TRAINING..... 38
40.0 SPECIAL PROJECTS ISSUES..... 39
41.0 CRAFT SPECIFIC CERTIFICATION PROGRAMS 40
42.0 SAFETY AUDITS/INSPECTION PROGRAMS..... 40

APPENDIX I MONTHLY SAFETY SUMMARY REPORT I-1
APPENDIX II ALCOHOL AND DRUG USE POLICY FOR CONTRACTORS II-1
APPENDIX III JOB SAFETY ANALYSIS (THE JSA) III-1
APPENDIX IV HOW TO CONDUCT A ROOT CAUSE ANALYSIS..... IV-1
APPENDIX V SUB-CONTRACTOR SAFETY QUESTIONNAIRE..... V-1



**GENERAL PROJECT SPECIFICATION FOR
PROJECT SAFETY REQUIREMENTS**

1.0 GENERAL

All personnel on this project, including the employees of Contractor, will be required to comply with these requirements. Contractor shall ensure and indicate that all its employees have received and read these requirements. These requirements shall be fully explained to each employee and Contractor and employee must acknowledge that the employee understands its content. Contractor must provide proof that employees have received this information which shall then be retained by Contractor with the employee's personnel file. In addition, Contractor shall comply with the following:

- Managers include safety, health and environmental considerations in ongoing business strategies, decisions, planning and execution.
- Managers maintain their safety, health and environmental knowledge at a level commensurate with their job responsibilities.
- For major projects, there is a structured plan for safety, health and environmental activities addressing the following areas throughout the project life: Risk Assessment, Prevention and Mitigation, Regulatory Compliance, Emergency Preparedness, Quality Assurance.
- Human factors are explicitly considered in facilities design and construction.
- Esso reserves the right to regulate smoking, open fires, carrying matches, and welding permits when and where deemed necessary in the interest of safety. Contractor shall be responsible for and so enforce Contractor's personnel, the personnel of all Sub-contractors, and visitors to comply with the regulations and restrictions as directed. Smoking, open fires, and similar regulations may vary at different locations.
- When certain areas are designated as "OPEN AREAS" the Esso Safety Representative will issue a "HOT WORK PERMIT" which will authorize open flames, burning, and welding activities during regularly scheduled working hours.
- Within certain areas designated as "RESTRICTIVE AREAS," the Esso Safety Representative will issue a "HOT WORK PERMIT" daily which will authorize open flames, burning, and welding activities during regularly scheduled work hours. Smoking will be permitted only in designated compounds. "OPEN



GENERAL PROJECT SPECIFICATION FOR
PROJECT SAFETY REQUIREMENTS

AREAS" shall be reclassified as "RESTRICTED AREAS" whenever designated by Esso and upon completion of the work.

(NOTE: This Hot Work Permit does not allow burning of trash and material cleared from ROW).

- No firearms are allowed on the job site without prior written approval by Esso.
- Use of photographic equipment requires specific approval by Esso.
- The Esso Safety Representative will verify adherence to procedures on a regular basis.
- Contractor is required to perform a self-assessment and audit of their safety program to insure compliance and effectiveness that will incorporate checks and authorizations that take a proactive approach that is consistent with risk or hazards that may be encountered. This self-assessment must be performed on a regular basis and documented for Esso review.
- Contractor's and Sub-contractors' project managers, construction managers, supervisors and safety advisors shall meet periodically to discuss project safety. The frequency, attendees and topics of these meetings shall be included in Contractor's safety execution plan.
- Contractor's and Sub-contractors' supervisors and safety advisors shall conduct daily periodic inspections of all facilities and the Work in progress at the Work Site.
- The frequency of Work Site inspections shall be included in Contractor's safety execution plan.
- Any safety rule infractions, unsafe working practices or unsafe conditions identified during these inspections shall be promptly corrected by Contractor.
- The periodic safety inspections shall be used by Contractor to evaluate the effectiveness of its safety program, and whether it is achieving the desired results.
- Although Contractor's line management is responsible for the safety of their personnel, Contractor's and Sub-contractors' safety advisors shall provide



**GENERAL PROJECT SPECIFICATION FOR
PROJECT SAFETY REQUIREMENTS**

overall leadership for Contractor's safety program and shall monitor work activities at the Work Site continuously.

- Esso reserves the right to inspect the Work Site at any time and will call Contractor's attention to infractions/hazards and expect prompt follow-up from Contractor. These Esso activities in no way relieve Contractor of its responsibilities for safe execution of the Work.
- Contractor shall promptly investigate any accident or incident which results in a fatality, lost time injury, damage to property or equipment in excess of US \$1,000 or a serious "near miss," i.e., an incident with the potential to cause a fatality, a lost time injury or damage in excess of US \$1,000. As part of this investigation Contractor shall complete a Root Cause Analysis of the incident as outlined in Appendix IV to this section.
- Normally, the investigation shall be conducted by a committee comprised of Contractor's superintendent responsible for the injured worker or incident, Contractor's safety advisor, a representative of Esso, and other representatives of Esso/Contractor/Sub-contractor who are familiar with the safety practices involved and who can contribute to the analysis of the incident and make recommendations for action to prevent recurrence.
- The investigation shall begin promptly after the accident or incident. Where applicable, photographs shall be taken of the scene of the accident, as well as any equipment or apparatus involved in the accident. The results of the investigation, together with the Root Cause Analysis referred to above and the committee's recommendations for preventive action, shall be submitted in writing to Esso within five working days after the incident occurs.
- Contractor shall also review and analyze all other injuries, including those requiring only first aid, to established trends that may indicate deviations from established work standards and safe working practices. Contractor, with Esso's approval, shall take appropriate corrective action, which may include publicizing the results of the analyses.
- Contractor shall keep written and photographic records of all fatalities, lost time injuries, and accidental property damage at the Work Site. The records shall include the reports of investigation results described in 25.11 above, as well as the identity of all witnesses, persons and property involved and corrective actions taken. Contractor shall keep these records two years after acceptance, and make them available to Esso upon request.



**GENERAL PROJECT SPECIFICATION FOR
PROJECT SAFETY REQUIREMENTS**

- Contractor shall prepare and submit to Esso by the fifth day of each month a safety report which covers the previous month's activities. The safety report, which shall be part of the monthly progress report, shall include:
 - A tabulation of all accidents and near misses that occurred during the reporting period, together with their apparent causes, in the format shown in Table 1.
 - A tabulation of all hazards observed at the Work Site during the reporting period, and a description of corrective actions taken to mitigate or eliminate them.
 - Graphs showing the recordable injuries rates and lost workday injuries rates since the beginning of construction activities.
 - A summary of Contractor's safety activities, problem areas and corrective actions, government visits and safety audits during the reporting period.
 - Contractor shall promote off-the-job safety

2.0 CLOTHING REQUIREMENTS

- 2.1 Long sleeve shirts shall be worn at all times (no tank tops). All shirts shall be tucked into trousers at all times. All shirts shall be hemmed at neck, sleeve, and tail.
- 2.2 Long pants are required at all times in all work areas.
- 2.3 Sandals, tennis shoes, or any other street type shoe will not be permitted. A well constructed boot/shoe that provides adequate protection with a hard flexible sole and steel toe shall be worn in all work areas. Exposure dictates whether or not an additional protective toe guard will be required. Contractor will be responsible for defining this requirement in its safety plan. All requirements as a minimum must meet OSHA 1926.96.
- 2.4 Loose fitting clothes or jewelry shall not be worn around moving machinery, padding machines, grinding operations, welding, etc.



GENERAL PROJECT SPECIFICATION FOR
PROJECT SAFETY REQUIREMENTS

- 2.5 Hair that could come in contact with, or be caught in machinery, shall be protected by a hard hat or hair net, as appropriate.

3.0 PERSONAL PROTECTIVE EQUIPMENT

- 3.1 Hard hats shall meet specifications contained in American National Standards Institute (ANSI), Z89.1-1981 and/or Z89.2-1971, or equivalent international standards. Hard hats are to be worn in all designated work areas as per OSHA 1926.100.
- 3.2 Safety glasses with side shields are required in construction areas at all times as per OSHA 1926.102.
- 3.3 Approved eye and face protection is required as follows: Goggles, welding hoods and shields, and face shields will be required to be properly worn when in the area of operations, such as when welding, burning, grinding, chipping, chemical handling, corrosive liquids or molten materials, drilling, sawing, driving nails, power actuated tools, concrete pouring, tampers and gas fueled operated equipment (e.g., chain saws). This section will also apply to those employees of Contractor who are assisting any worker as an apprentice or helper. Prescription glasses must be approved safety glasses or approved safety glasses and frames or approved eye protection shall be worn as per OSHA 1926.102.
- 3.4 Only approved hearing and respiratory equipment shall be worn. The selection, fitting, and maintenance requirements shall be met by Contractor as per OSHA Technical Requirements 1926.101.
- 3.5 Safety harnesses will be required exclusively and shall be worn by all employees when working 6 feet (2.0 meters) or more above the ground or when working in a precarious position. The shock absorbing lanyard shall be securely attached to the employee 100% of the time and shall allow a maximum fall distance of 6 feet (2.0 meters). Safety harnesses shall also be worn and attached to the tie-off rail when working out of extendible and articulating boom platforms and to vertical drop lines when working from suspended scaffolding. Safety belts shall not be allowed on worksite as per OSHA 1926.104 and 1926.105 including all requirements of 1926.500 through 1926.503.



**GENERAL PROJECT SPECIFICATION FOR
PROJECT SAFETY REQUIREMENTS**

- 3.6 Seat belts shall be worn by all employees operating any motor vehicle and any equipment with rollover protection structures. For equipment designed by manufacturer without rollover protection, seat belts may be waived.
- 3.7 Safety nets shall be provided when work places are more than 25 feet (8.0 meters) above the ground where the use of other fall protection devices is impractical as per OSHA 1926.105.
- 3.8 Contractor must consult with the Esso Safety Representative and follow all applicable safety rules and regulations concerning the following:
- Use of lasers
 - Radiation sources
 - Explosive power tools
 - Hazardous materials

4.0 SIGNS, SIGNALS, BARRICADES, AND LIGHTS

- 4.1 Signs, signals, and barricades shall be visible at all times where a hazard exists including all requirements of OSHA 1926.200 through 1926.203.
- 4.2 All streets, roads, highways, and other public thoroughfares which are closed to traffic shall be protected by effective barricades on which shall be placed acceptable and highly visible reflective warning signs and flashing lights (when required). Barricades shall be located at the nearest intersecting public highway or street on each side of the blocked section.
- 4.3 All open trenches and other excavations shall be provided with suitable barriers, signs, and lights to the extent that adequate protection is provided to the public. Obstructions, such as material piles and equipment, shall be provided with similar warning signs and lights.
- 4.4 All barricades and obstructions shall be illuminated by means of warning lights from one hour before sunset to one hour after sunrise. Materials stored upon or alongside public streets and highways shall be so placed, and the work at all times shall be so conducted, as to cause the minimum obstruction and inconvenience to the traveling public.
- 4.5 All barricades, signs, lights, and other protective devices shall be installed and maintained in conformity with applicable statutory requirements and, where within railroad and highway ROW, as required by the authority having



**GENERAL PROJECT SPECIFICATION FOR
PROJECT SAFETY REQUIREMENTS**

jurisdiction thereover, if requirements are more stringent than OSHA requirements.

- 4.6 When any work is performed at night or where daylight is shut off or obscured, Contractor shall provide artificial light sufficient to permit work to be carried on efficiently, satisfactorily, and safely, and to permit thorough inspection. During such time periods the access to the place of work shall also be clearly illuminated. All wiring for electric light and power shall be installed and maintained in accordance with permanent facilities codes and requirements, securely fastened in place at all points, and shall be kept as far away as possible from telephone wires, signal wires, and wires for firing blasts.
- 4.7 Signs, signals, and barricades shall be removed when the hazard no longer exists.
- 4.8 Contractor's employees working in an area of potential traffic hazard shall wear approved reflective type vests.

5.0 RIGGING EQUIPMENT FOR MATERIAL HANDLING

NOTE: All rigging operations shall comply with OSHA 1926.251.

- 5.1 All rigging equipment shall be free from defects, in good operating condition, and maintained in a safe condition.
- 5.2 Rigging equipment shall be inspected by a designated, competent employee of Contractor prior to initial use on the job site and monthly thereafter to ensure that it is safe. Records shall be kept on job site of each inspection by Contractor and shall be made available to Esso upon request. All rigging equipment shall be color coded for inspection identification.
- 5.3 Contractor's damaged rigging equipment shall be immediately removed from service by Contractor.

6.0 HAND AND POWER TOOLS

NOTE: All hand and power tool operations shall comply with OSHA 1926.300 - 1926.307.



**GENERAL PROJECT SPECIFICATION FOR
PROJECT SAFETY REQUIREMENTS**

- 6.1 All hand and power tools, whether furnished by Contractor, or by Contractor's employee, shall be maintained in a safe condition.
- 6.2 Contractors shall not issue nor permit the use of unsafe hand or power tools.
- 6.3 Electrical power tools shall be grounded/earthed or double insulated with proper assured equipment grounding inspections or Ground Fault Circuit Interrupter protection provided. Portable welding machines having electrical receptacles shall be grounded.
- 6.4 Pneumatic power tools shall be secured to the hose or whip by some positive means. Safety pins shall be used in all connections.
- 6.5 Only properly trained Contractor employees shall operate power actuated tools. Certification records, employee certification cards, or equivalent certification documentation shall be maintained by Contractor on each of its employees using power actuated tools during performance of the work.
- 6.6 All grinding machines shall conform to OSHA and ANSI, or local equivalent requirements, if local requirements are more stringent. Reference 1926.303
- 6.7 Cords, leads, and hoses shall be kept at least 7 feet (2.10 meters) off the ground or whatever height is necessary to be protected from traffic and tripping hazards.

7.0 COMPRESSED GASES

NOTE: Using, transporting, moving and storing compressed gas cylinders must meet requirements of OSHA (29 CFR 1926.350).

- 7.1 Compressed gas cylinders shall be secured in an upright position at all times. Location of cylinder storage areas must be approved by the Esso Safety Representative.
- 7.2 When transporting, moving, and storing cylinders, valve protection caps shall be in place and secured.
- 7.3 Cylinders shall not be hoisted by magnets or choker slings. Valve protection caps shall not be used for hoisting cylinders.
- 7.4 Cylinders shall be protected from overhead work at all times.



**GENERAL PROJECT SPECIFICATION FOR
PROJECT SAFETY REQUIREMENTS**

- 7.5 Cylinders shall be kept away from sparks, hot slag, and flames or adequately protected.
- 7.6 Cylinders shall not be placed where they can become part of an electrical circuit.
- 7.7 Cylinders shall be labeled as to the nature of their contents.
- 7.8 Oxygen cylinders in storage shall be separated from fuel gas cylinders or combustible materials a minimum of 20 feet (6.0 meters), or by a noncombustible barrier at least 5 feet (2.0 meters) high having a fire resistant rating of at least one-half hour. Empty cylinders shall be separated as above from full cylinders and stored with like cylinders.
- 7.9 "No Smoking" signs shall be posted at storage areas and signs shall clearly indicate contents of cylinders.
- 7.10 Anti-flash back arresters shall be installed on all oxygen and acetylene cylinders.

8.0 SCAFFOLDS

- 8.1 Footings or anchorage for any scaffold shall be sound, rigid, and capable of carrying the maximum intended load without settling or displacement.
- 8.2 No unstable objects such as concrete blocks shall be used to support scaffolds or planks.
- 8.3 Any part of a scaffold weakened or damaged shall be repaired or replaced immediately.
- 8.4 All scaffold planking shall be free of knots and cracks and shall completely cover the work platform.
- 8.5 Scaffold planks shall be tight, cleated at both ends, or overlapped a minimum of 12 inches (0.385 meters) and nailed or bolted to prevent movement. Overlaps are to occur directly above scaffold supports.
- 8.6 Safe access shall be provided to the scaffold platform. Specifically, a safe means of access from a ladder to the platform shall be provided.



GENERAL PROJECT SPECIFICATION FOR
PROJECT SAFETY REQUIREMENTS

- 8.7 Scaffolds shall be equipped with a top rail made of timber not less than 2-by-4 inches (or equivalent strength), 42 inches (1.1 meters) high; a 21 inch (0.50 meters) high midrail, made of timber not less than 1-by-6 inches (or equivalent strength); and toeboards shall be installed on all open sides and ends of scaffold platforms 10 or more feet (3.0 meters) above the ground floor.
- 8.8 Scaffolding not adaptable to guard rails shall require the use of safety harnesses with the shock absorbing lanyard attached to a secure substantial object.
- 8.9 Mobile scaffolding casters shall be secured and locked prior to mounting.
- 8.10 No personnel or loose material shall be on mobile scaffold when it is being relocated.
- 8.11 Contractor's employees working swing stages, boatswain chairs, floats, suspended scaffolds, and needle beam scaffolds, etc., shall wear safety harnesses with shock absorbing lanyards attached to an independent lifeline.
- 8.12 A proper scaffold inspection and tagging system shall be maintained.
- 8.13 Quick mounted scaffold is prohibited.

NOTE: International standards may differ but as a minimum the construction for scaffolding shall meet the requirements of OSHA (29 CFR 1926.451).

9.0 JOB SITE TRANSPORTATION RULES

- 9.1 Drivers of motor vehicles shall have valid drivers license and be instructed to exercise judgment as well as observe posted speed limits. Much slower speeds are necessary in congested areas.
- 9.2 All Contractor entrance and exit routes shall be adequately marked.
- 9.3 Pedestrians and bicycles have ROW over motorized traffic.
- 9.4 Horns shall be used when passing and at all blind corners.



**GENERAL PROJECT SPECIFICATION FOR
PROJECT SAFETY REQUIREMENTS**

- 9.5 Established hand signals or turn signals are to be used.
- 9.6 Reckless driving or other non-observance of these instructions will be cause for withdrawal of driving privileges on the project.
- 9.7 No two-wheel motorized vehicles are allowed on the job site. Any All Terrain Vehicle used on the job site shall be four-wheeled, not three-wheeled.

10.0 CRANES, DERRICKS AND LIFTING EQUIPMENT

Contractor is required to develop a Crane and Lifting Equipment Procedure that will address as a minimum OSHA 1926.550 through 1926.556 and Esso Onshore Crane/Lifting Safety Management Guidelines. This procedure must address all equipment to be used by Contractor or Sub-contractors including the following:

- Typical Onshore Crane/Lifting Safety Management System
- Personnel, responsibilities, training, certification
- Equipment, inspection, maintenance
- Safety checklist
- Erection and climbing
- Operating procedures and precautions
- Crane log
- Prequalification process
- Lift planning process (job safety analysis)
- Critical load and site factors and plan
- Lift evaluation form
- Permits
- Third party crane responsibility
- Performance monitoring tools
- Safe start-up, shutting down and securing equipment
- Crane suspended personnel basket requirements
- Hazard awareness checklist
- Moving crane checklist and procedure
- Pick and carry checklist
- Use of crane rating charts
- Mobile crane selection summary
- Specific inspection items
- Electronic operating aids
- Agreed objectives



GENERAL PROJECT SPECIFICATION FOR
PROJECT SAFETY REQUIREMENTS

- Resource responsible and accountable for implementation
 - Assessment of improvement
 - Management of change
 - Measurement process
- 10.1 All cranes and derricks shall be certified as being in safe operating condition by Contractor prior to using the crane or derrick on the job site. This certification shall be maintained by Contractor and made available to Esso upon request.
- 10.2 All crane operators shall be properly licensed and certified by a competent person who is capable of identifying existing and predictable hazards in the surroundings or working conditions which are unsanitary, hazardous, or dangerous to employees and who has authorization to take prompt corrective measures to eliminate them. Certification records shall be maintained on job site by Contractor and made available to Esso on request.
- 10.3 The swing radius of cranes shall be barricaded for protection of pinch points. The load line will be secured when work has been stopped or at the end of day shifts.
- 10.4 Hand signals prescribed by local standards shall be posted at an operator's station.
- 10.5 Manufacturer's specifications shall be observed by Contractor.
- 10.6 Equipment shall not be operated where any of the equipment or the load will come within 15 feet (5.0 meters) of electrical distribution or transmission lines without a "close proximity work permit" approved by site management.
- 10.7 Contractor's employees shall not ride the headache ball, hook, or load being handled by the crane.
- 10.8 Equipment shall not be lubricated while in use.
- 10.9 Rated load capabilities, recommended operating speeds, special hazard warning, specific hand signal diagram, and special instructions shall be visible to the operator while at the control station.



**GENERAL PROJECT SPECIFICATION FOR
PROJECT SAFETY REQUIREMENTS**

- 10.10 Contractor's employees shall not be allowed to work under the load of cranes. Tag lines shall be used on all loads. Special caution should be used in concrete bucket operations.
- 10.11 All equipment carrying loads shall have an Employee walk ahead of the load to watch for hazards and blind spots. All loads being walked shall have tag line attached to control load.
- 10.12 All crane and lifting equipment shall be operated and meet all requirements outlined in the ECI Onshore Crane/Lifting Safety Management Guide

11.0 CRANE SPECIFICS

- 11.1 A complete and documented annual inspection must be performed before the machine arrives on site and an annual inspection must be performed thereafter. Cranes and derricks shall be inspected prior to use and at monthly intervals. Records shall be maintained on job site of these inspections by Contractor and copies shall be made available to Esso.
- 11.2 The complete annual inspection of all structural crane parts including NDE test of welded joints by a competent person qualified in accordance with OSHA 29 CFR Part 1926.32 (f), should be furnished by the crane supplier prior to the erection of the crane. A copy of this inspection and NDE test results should be kept on site. The inspection should also be certified by a registered engineer.
- 11.3 Cranes shall have flags or other indicators on the jib identifying the working load radius to the operator.
- 11.4 Cranes shall have limiting devices to control:
 - Trolley travel at both ends of the jib
 - Anti-two blocking/overhoisting limit device
 - Operating radius in accordance with lifted load
 - Pressures in hydraulic or pneumatic circuits
- 11.5 Load limiting devices, and acceleration and deceleration limiters, when provided, shall be installed in enclosures that can be locked or sealed to inhibit unauthorized tampering.



**GENERAL PROJECT SPECIFICATION FOR
PROJECT SAFETY REQUIREMENTS**

- 11.6 The operator should be trained, experienced and qualified for the operation of that specific make and model of crane. Operator experience documentation should be provided by the utilizing Contractor even if it is using a Sub-contractor on site.
- 11.7 The manufacturer's operator manual shall be kept with the crane while it is on site.
- 11.8 A wind velocity indicating device shall be mounted at or near the top of the crane. A velocity readout shall be provided at the operator's station in the cab and a visible or audible alarm shall be triggered in the cab and at remote control stations when the preset wind velocity has been exceeded.
- 11.9 Regular inspections and maintenance of the cranes should be conducted and performed in accordance with the manufacturer's specifications and ANSI Standards.
- 11.10 All crane operations shall be performed in accordance with ANSI B30.3-1984 and ANSI B30.4-1981.
- 11.11 Personnel lifts can only be made with approved personnel platforms, and then only after a successful, unoccupied, trial proof test. A trial lift of at least 200% of the platform's rated capacity, for at least five minutes time, must be performed immediately prior to placing personnel on the platform. A competent person must inspect the crane, platform, rigging, and ground after the trial lift. Any deficiencies noted will be corrected, and another proof test shall be conducted, until the proof testing requirements are satisfied. A trial lift will be performed each time the crane is moved.

12.0 EQUIPMENT AND MOTOR VEHICLES, AND MARINE OPERATIONS

NOTE: All motor vehicles, mechanical equipment, and marine operations shall be maintained and operated in accordance to OSHA 1926.600 - 1926.606.

- 12.1 All equipment must be inspected daily before use by Contractor's operator. Formal inspections must also be made by Contractor at 30 day intervals with proper documentation maintained at the job site. Copies shall be made available to Esso upon request.
- 12.2 All hoisting equipment shall have a certified inspection report within the previous 12 months.



**GENERAL PROJECT SPECIFICATION FOR
PROJECT SAFETY REQUIREMENTS**

- 12.3 All hoisting equipment shall have manufacturer's operator's manual in the cab at all times along with load and radius charts.
- 12.4 Defective equipment shall be repaired or removed from service immediately.
- 12.5 All rubber-tired, materials handling equipment (MHE), self-propelled scrapers, rubber-tired front-end loaders, rubber-tired bulldozers, wheeled-type agricultural and industrial tractors, crawler-type loaders and motor graders shall be equipped with roll-over protective structures and seat belts as per manufacturer specification.
- 12.6 All Contractor's operators of construction equipment should be properly licensed and certified by a competent person. Copies of the certifications shall be maintained on the job site by Contractor and made available to Esso upon request.
- 12.7 All equipment with an obstructed view to the rear must have a reverse signal alarm audible above the surrounding noise level or a flagman.
- 12.8 All cracked and broken glass shall be replaced before bringing vehicles on the job site. If glass is broken or damaged on job site and if damage is severe enough to cause a potential safety problem, the machine shall be stopped until such damage has been repaired.
- 12.9 Vehicles used to transport employees shall have seats firmly secured and adequate for the number of employees to be carried and all passengers should be properly seated or firmly seated in the bed of the truck. Standing or kneeling on the back of moving vehicles is prohibited.
- 12.10 Locations for storage of all fuels, lubricants, starting fluids, etc., shall be reviewed by Esso prior to use by Contractor for storage.

13.0 ELECTRICAL

- 13.1 All electrical work, insulation, and wire capacities shall be in accordance with the pertinent provisions of the permanent facilities codes and requirements.
- 13.2 Contractor shall develop a ground fault program in accordance with OSHA Requirements and approved Esso requirements.



**GENERAL PROJECT SPECIFICATION FOR
PROJECT SAFETY REQUIREMENTS**

13.3 Contractor shall develop and implement a lockout/tagout procedure in accordance to OSHA 1926.461 and 1926.417 and strictly adhere to the use of this procedure. The Esso Safety Representative will verify adherence to the procedure on a regular basis.

13.4 All temporary power panels shall have covers installed at all times. All open or exposed breaker spaces shall be adequately covered.

14.0 LADDERS AND STAIRWAYS

NOTE: Ladders and stairways shall meet OSHA 1926.1050 through 1926.1060 requirements.

14.1 The use of ladders with broken or missing rungs or steps, broken or split rails or other defective construction is prohibited.

14.2 Ladders shall extend no less than 36 inches (1.0 meter) above landing and be secured to prevent displacement.

14.3 Portable ladders must be equipped with safety shoes.

14.4 Wooden ladders shall not be painted.

14.5 Metal or conductive ladders shall not be used.

14.6 Ladders must be inspected daily before use, formal inspections must also be made by Contractor at 30 day intervals and documented.

14.7 Ladders shall be used for means of access only and shall not be used in place of scaffold.

14.8 Every flight of stairs having four or more risers shall be equipped with standard stair railings. Stairs are not to be used until risers, landings, and railings are securely installed. Treads will be poured as soon as possible where poured treads apply.

14.9 Debris and other loose materials shall not be allowed to accumulate in stairwells.



GENERAL PROJECT SPECIFICATION FOR
PROJECT SAFETY REQUIREMENTS

15.0 FLOOR AND WALL OPENINGS AND STAIRWAYS

- 15.1 Floor and wall openings shall be guarded by a standard guardrail, midrail, and toeboard, or adequately covered.
- 15.2 Guardrail must be of sufficient strength to support 200 pounds of force when applied at midspan of the guardrail parallel with the floor and perpendicular to the guardrail.
- 15.3 Covers must be adequately secured to prevent displacement and have "Danger" signs attached identifying the hazard.

16.0 EXCAVATIONS AND TRENCHING

Trenching and excavations must meet the minimum requirement of OSHA 1926.650 - 1926.652.

- 16.1 A competent person must be designated and trained in soil classification and the recognition of trenching and excavation hazards and be present during all trenching operations.
- 16.2 Appropriate documentation to meet trenching and excavation standards is to be kept on site.
- 16.3 Prior to opening any excavation or trench, Contractor must notify Esso. In addition, Contractor shall contact any other necessary personnel to determine whether underground installations, e.g., sewer, telephone, fuel, electric lines, etc., may be encountered and where they are located. Excavation permits shall be required.
- 16.4 Excavations and trenches shall be inspected by a competent person daily and after every rainfall to determine if they are safe.
- 16.5 All banks 5 feet (1.5 meters) high or more shall be sloped to 34-degrees unless soil is analyzed by a competent person allowing a greater slope angle, or shall be adequately shored.
- 16.6 Ladders or steps shall be provided and secured in all trenches 4 feet (1.2 meters) or more in depth. Ladders or steps shall be located to require no more than 25 feet (7.5 meters) of lateral travel before having access to egress and shall extend 3 feet (90 centimeters) above the top of the trench



**GENERAL PROJECT SPECIFICATION FOR
PROJECT SAFETY REQUIREMENTS**

bank. This requirement shall be in affect any time personnel are in trench or excavation.

- 16.7 Material excavated shall be stored at least 2 feet (0.6 meters) from the edge of the excavation or trench and shall be shored to prevent material from falling into the excavation.
- 16.8 All trenches and excavations shall be properly barricaded to prevent persons from walking into them. Pipeline trench will be excluded except in areas of road crossing and public access.
- 16.9 All walkways or ramps crossing over excavations shall be securely fastened and equipped with standard guardrail.

17.0 STEEL ERECTION

NOTE: Reference OSHA 1926.750 - 1926.752.

- 17.1 At no time shall there be more than 4 floors or 48 feet (14.63 meters) of unfinished bolting or welding above the foundation or uppermost permanently secured floors.
- 17.2 A temporary and/or permanent floor shall be maintained within two stories or 30 feet (9.14 meters) whichever is less, below and directly under that portion of each tier of beams on which any work is being performed.
- 17.3 Planking or metal decking in temporary floors shall be of proper strength and thickness to carry the working load. Decking shall be secured to prevent movement.
- 17.4 Standard guardrail and toeboards shall be installed around open sides of permanent floors. During structural steel assembly, a safety railing (cable) of one-half inch diameter shall be installed approximately 42 inches high, recessed into the interior of floor around all temporary floors.
- 17.5 Where fall distances exceed 25 feet (7.62 meters) safety nets shall be provided, if the use of scaffolds, ladders, catch platforms, or safety belts with lanyards attached to lifelines or other substantial objects is impractical.
- 17.6 Tag lines shall be used to control all loads.



GENERAL PROJECT SPECIFICATION FOR
PROJECT SAFETY REQUIREMENTS

- 17.7 Containers shall be provided for storing or carrying bolts or rivets. When bolts, drift pins, or rivet heads are being removed, a means shall be provided to prevent accidental displacement. Tools shall be provided and lanyards to prevent falling.
- 17.8 During the final placing of solid web structural members, the load shall not be released from the hoisting line until the members are secured with not less than two bolts, or equivalent, at each connection.
- 17.9 Contractor shall not allow any of Contractor's employees to walk the steel. Contractor's employees must be tied off and "coon/straddle" the beam until safety cables are provided to which employees shall tie off. Two shock absorbing lanyards will be needed to ensure 100% tie-off.
- 17.10 A safe means of access to the level being worked shall be maintained. Climbing and sliding columns are prohibited and are not considered safe access.

18.0 CONFINED AREAS OR SPACES

- 18.1 Contractor shall develop an entry procedure to be used when Contractor's employees are required to enter confined areas or spaces. Such areas include storage tanks, process vessels, bins, boilers, ventilation or exhaust ducts, sewers, underground utility vaults, tunnels, pipelines, open-topped pits, basements, and temporary wood framing covered with plastic.
- 18.2 All of Contractor's employees who are required to enter confined areas or spaces shall be instructed as to the nature of hazards involved, necessary precautions to be taken and in the use of protective and emergency equipment required.
- 18.3 Before Contractor's employees are permitted entry into any confined area or space, the atmosphere within the space shall be tested to determine the oxygen level and concentrations of flammable vapors, gases, toxic contaminants. Contractor needing access to the confined area shall furnish the testing equipment and a person competent in the use of the testing equipment.
- 18.4 When welding, cutting, or heating in confined areas or spaces, ventilation shall be provided. When sufficient ventilation cannot be provided without



GENERAL PROJECT SPECIFICATION FOR
PROJECT SAFETY REQUIREMENTS

blocking the means of access, Contractor's employees shall be protected by air line respirators and an employee of Contractor shall be stationed outside the confined area to maintain communication with those working within and to aid them in an emergency. Stand-by employee should be trained in emergency procedures.

NOTE: As a minimum all confined spaces must meet or exceed OSHA (CFR 1910.146). Esso maintains the right to increase requirement if necessary.

19.0 HOUSEKEEPING

NOTE: VERY IMPORTANT Contractor will be required to keep all work areas under tight housekeeping requirements at all times. It is not acceptable to wait until the end of the day to start clean-up. Housekeeping must be maintained throughout the day. NO EXCEPTIONS to this requirement. Contractor will be monitored on a regular basis by Esso personnel. Project Management will be held accountable.

- 19.1 During the course of construction, all debris and scrap material shall be kept away from the work area.
- 19.2 Containers shall be provided by Contractor for the collection and separation of waste, trash, oily and used rags and other refuse. Metal (dumpster type) containers must be used and emptied promptly.
- 19.3 Garbage and other waste shall be disposed of at frequent and regular intervals.
- 19.4 Contractor shall notify Esso of any hazardous waste it will generate during performance of the work. Contractor has the direct responsibility of maintaining proper storage of these wastes while on site. Reference Coordination Procedure Section 30, Environmental Management and Contractor's Waste Management Plan.
- 19.5 Contractor shall not bury, burn, nor in any way dispose of a chemical on the job site without permission from Esso.
- 19.6 Materials and supplies shall be stored in locations which will not block accessways, and be arranged to permit easy cleaning of the area. In areas



GENERAL PROJECT SPECIFICATION FOR
PROJECT SAFETY REQUIREMENTS

where equipment might drip oil or cause other damage to the ground or floor's surface, a protective cover of heavy gauge, flame resistant, oil-proof sheeting shall be provided between the equipment and the ground or floor surface sheeting so that no oil or grease contacts the soil or concrete. This requirement is applicable to finished and unfinished floors and ground.

- 19.7 All hoses, cables, extension cords, and similar materials shall be located, arranged, and grouped so that they will not block any accessway and will permit easy cleaning and maintenance.



GENERAL PROJECT SPECIFICATION FOR
PROJECT SAFETY REQUIREMENTS

20.0 CONTRACTOR RESPONSIBILITIES - MEDICAL SERVICES

NOTE: Refer to Coordination Procedure Section 23, Occupational Health, Medical Facilities and Sanitation.

Contractors have the following responsibilities:

- Ensure the availability of professional medical service personnel.
- Prior to commencement of work, make provisions for prompt medical attention.
- Ensure that first aid supplies approved by the Esso consulting physician shall be easily accessible when required.
- Provide adequate number of first aid kits and supplies approved by the Esso consulting physician. First aid kits shall be in a weatherproof container with individual sealed packages for each type of item. Contents of the first aid kits shall be checked by Contractor before being sent to the job site and at least weekly during performance of the work to ensure that expended items are replaced.
- Provide proper equipment for prompt transportation of the injured person to a treatment area.
- Emergency numbers of the physicians, medivac and ambulance shall be conspicuously posted.
- Complete and retain on file all employer's "First Report of Injury" and OSHA Form 200, or international equivalent, and provide Esso a copy on request.
- A daily record shall be kept on all employees requiring first aid treatment.
- Contractor shall make every effort to work with medical advisor with the best interest of the employee to propose and provide "alternative" or "restricted" work duty when possible.



GENERAL PROJECT SPECIFICATION FOR
PROJECT SAFETY REQUIREMENTS

21.0 MINOR CUTS, SCRATCHES, BRUISES, ETC. - FIRST AID

- 21.1 Each occupational illness or injury shall be reported immediately by Contractor's employee to Contractor or the designated safety representative.
- 21.2 All personal injuries and illnesses treated or reported shall be recorded on a daily First Aid Log. This log should contain such information as employee's name, badge number, foreman, nature and cause of injury, treatment administered, date, time, and first aid attendant's name. Contractor shall maintain such data for Esso's review.
- 21.3 Contractor's should treat the injured employee as often as necessary to ensure complete recovery or the decision is made to seek medical treatment elsewhere.

22.0 MEDICAL CASES NOT REQUIRING EVACUATION

- 22.1 Contact Contractor's first aid attendant or designated safety representative regarding medical cases not normally requiring evacuation such as minor lacerations, embedded foreign bodies in eye, minor sprains, strains, etc.
- 22.2 Contractor must provide proper equipment for prompt transportation for the injured person to an infirmary/trauma area.
- 22.3 A representative of Contractor should always accompany the injured employee to the medical facility and remain at the facility until the employee is ready to return. Contractor has the responsibility to ensure that the employee has or receives necessary forms, e.g., authorization slips, return to work notices, etc.
- 22.4 If it is necessary for Contractor's medical personnel to accompany the injured employee, provisions must be made by Contractor to have other qualified medical personnel available, properly trained and certified in first aid, to render first aid during the absence of the regular physician, physician's assistant, or nurse.



**GENERAL PROJECT SPECIFICATION FOR
PROJECT SAFETY REQUIREMENTS**

- 22.5 If it is necessary to call the medical facility to be utilized, this call should be made by the designated Contractor representative while the injured employee is being transported.
- 22.6 If the employee is able to return to the job site the same day, they should bring with them a statement from the attending physician containing such information as date, employee's name, date they are able to return to work, regular or restricted duty, date they are to return to doctor, diagnosis, signature and address of doctor. If the injured employee is unable to return to the job site the same day, the employee who transported them should immediately notify Contractor Management and Esso.
- 22.7 Contractor should designate one employee to keep files on all medical cases and retain all medical statements in this file.

23.0 MEDICAL CASES REQUIRING EVACUATION SERVICE

Examples of medical cases requiring evacuating services include severe head injuries, amputations, heart attacks, etc. Should evacuation service be necessary, the following procedures should be taken immediately:

1. Contact Contractor or nearest employee properly trained and certified in first aid.
2. While first aid is being administered, arrange necessary transportation.
3. While the injured employee is being transported, Contractor should contact the medical facility.
4. One designated Contractor representative should accompany the injured employee to the medical facility and remain at the facility until final diagnosis and other relevant information is obtained.



GENERAL PROJECT SPECIFICATION FOR
PROJECT SAFETY REQUIREMENTS

24.0 CONTRACTOR / SUB-CONTRACTOR DOCUMENTATION

Safety Performance Notebook

Directions for completing each section of the Safety Performance Notebook follow.

Table of Contents

Sections to be maintained and updated in the Table of Contents.

Section I - Contractor/Sub-contractor Information

Include the following:

- Names, addresses, phone numbers, etc., of company office and officers
- Worker's Compensation carrier/employer liability insurer, contact name and address with phone number
- Certificate of Insurance - current
- Union information (if any), local number and name
- Safety Performance Information
- Awards received past two years, if any OSHA 200 Log (or equivalent) - Previous three years

Section II - Contractor/ Sub-contractor Safety Information

Include the following:

- Copy of safety program
- New hire and visitor orientation
- Toolbox meeting reports
- Written HazCom program or local equivalent
- Training program
- Written respirator program (if required)
- Other job specific inspection programs
- Self assessment audit program



**GENERAL PROJECT SPECIFICATION FOR
PROJECT SAFETY REQUIREMENTS**

Section III - Contractor/Sub-contractor Safety Performance

Include the following:

- Injury performance records
- First Aid Log (Monthly)
- First Report of Injury
- Accident Investigation Reports
- Current Year OSHA 200 Log (or equivalent)
- Area safety inspection reports to include corrective action taken (monthly)
- Copies of Monthly Report Form SR-1
- Incentive awards and safety goals obtained

Section IV - Safety Enforcement Actions

Include the following:

- Letters written to obtain compliance
- Reports documenting removal of employees from the project for safety reasons
- Work stoppages to correct safety problems

Section V - Site Specific Safety Requirements

Include the following applicable procedures must be approved by Esso Safety Representative.

Section VI - Perform Accident/Injury or Near Miss Investigation(s) Using Esso Format

Contractor is required to develop procedures for incident investigation and reporting of incidents, near-misses and unsafe acts.

Contractor must ensure that:

- A system is in place for reporting, investigating, analyzing and documenting safety, health, environmental and regulatory compliance incidents and significant near-misses.
- Criteria and scope for reporting and review of incidents and near-misses are defined in specific incident reporting guidelines issued by ECI Headquarters, Affiliate Headquarters and the unit.



**GENERAL PROJECT SPECIFICATION FOR
PROJECT SAFETY REQUIREMENTS**

- Responsibility is assigned for ensuring that such systems are in place and followed and that qualified personnel conduct investigations and analyses.
- Procedures exist for determining the scope and manner of investigations of incidents and significant near-misses based upon actual or potential consequences and legal considerations.
- Procedures exist for determining when medical evaluation or alcohol and drug testing is conducted in connection with an incident.
- A program is in place to encourage near-miss reporting.
- The role of human factors and the effectiveness of Systems are analyzed in investigations.
- Findings are retained, periodically analyzed to determine where improvements to practices, standards, procedures or management systems are warranted and used as a basis for improvement.
- An information base of incidents and near-misses, including root causes and corrective actions, is maintained to assist in identification of improvements and stewardship.
- Identified improvements are reviewed with Esso management and decisions implemented.

This information is required for all lost time injuries, potential or near-miss incidents and fatalities. The following should be included in the report:

- Use information from Contractor's Safety Performance Notebook for backup information that may be required
- Toolbox topics covered relative to the incident
- Safety Orientation, Root Cause Analysis, Accident Investigation Report, etc.
- Contractor is required to make immediate notification to Esso



GENERAL PROJECT SPECIFICATION FOR
PROJECT SAFETY REQUIREMENTS

25.0 REQUIRED ACCIDENT/INJURY INFORMATION

25.1 The following information is required in the event of Contractor/Sub-contractor injury, lost time accident or fatality:

- Contractor is required to make immediate notification to Esso.
- Contractor/Sub-contractor names and addresses of project management (project manager, construction manager, safety manager, services manager, etc.)
- Contractor or Sub-contractor safety orientation and evidence showing that individual completed orientation when they started work.
- The Sub-contractor or Contractor safety program. Highlight the appropriate part dealing with the referenced accident.
- The Sub-contractor or Contractor work procedures on the work under way when the incident occurred.
- Contractor safety meetings and/or any Sub-contractor safety meetings (if related)
- Contractor safety inspections and/or Sub-contractor safety inspection(s) (highlight related items)
- Letters to Esso or Sub-contractor regarding safety
- Contractor/Sub-contractor safety performance on the project, Contractor/Sub-contractor safety performance as a company for the year on their OSHA 200 Log or equivalent
- Contractor/Sub-contractor incidence rate of lost workday cases and OSHA 200 Log or equivalent for the company
- Copy of Contractor's insurance certificates or information on the carrier and a letter from Sub-contractor's insurance carrier referencing the Sub-contractor's safety.
- Site Safety Regulations that pertain to the incident
- Any site safety topics that pertain to the incident
- Any site safety programs that pertain to the incident
- Treating physician's name, hospital, or clinic address, etc., and a doctor's statement on the injury the employee received (also return to work notice)



**GENERAL PROJECT SPECIFICATION FOR
PROJECT SAFETY REQUIREMENTS**

- Medical records on the employee where possible
- Job description for Contractor/Sub-contractor employee (may include specific references to safety)
- Signed statements from designated Contractor/Sub-contractor representatives concerning the employee's safety performance on the job or safety requirements for the job, etc.
- Sketches of the accident area
- Exact name, address, and project location of foreman or supervisor. Also, what they were doing when the accident occurred. How far away from the area, etc.
- Signed statements from all witnesses with names and addresses
- Safety violations issued, if any
- Coroner's report, if fatality
- Full accident investigation
- First Report of Injury
- Accident and area photographs
- Copy of any procedure(s) - lockout, tagout, danger tags, etc.
- Any client related report or training information
- Any union training program including safety that the particular employee's union has at its locale
- A statement from Contractor regarding any type of useful information that could be used in defense
- Documentation reflecting monies expended by Contractor to have safety problems corrected, e.g., housekeeping, handrails, and floor hole covers, installations, etc.
- Specifically list enforcement measures taken by Contractor to enforce compliance of Sub-contractors with project safety procedures, e.g., withholding payment of invoices, instances of the Esso or Contractor stopping work until safety hazards are corrected.



GENERAL PROJECT SPECIFICATION FOR
PROJECT SAFETY REQUIREMENTS

26.0 SAFETY RULES AND PROCEDURES

Contractor shall:

- Develop Safety Rules and Procedures.
- Identify applicable procedures for work to be performed.
- Write Site Specific Safety Procedure Manual incorporating applicable safety procedures.
- Issue Project Safety Procedures manual to Esso.

27.0 HAZARDOUS MATERIALS PROCESS AND/OR CHEMICALS

Contractor shall:

- Contractor is required to develop a system that will ensure that information on potential hazards of materials involved in operations is kept current and, based on assessed risk to personnel, exposures are monitored, proper protection measures are communicated, and pertinent health data are recorded and reviewed.
- Contractor must develop and maintain documentation for purchase, transport, handling, storage and disposal of hazardous materials that are clearly defined for each location.
- Contractor must develop a system that will ensure that hazardous materials are not accepted from suppliers without associated material safety data sheets (M.S.D.S.).
- All personnel are provided with information about the potential hazards of the materials they are exposed to in their work.
- Contractor must ensure that exposure limits to hazardous materials are set. Based on assessed risk, personnel exposure is monitored, recorded, and subject to periodic review by Esso management.
- If there are potential hazards of products produced in operations, the Contractor must ensure that information on potential hazards associated with products and guidance to enable proper handling, use, and disposed is documented and communicated.
- Identify processes and chemicals that may expose employees to potentially hazardous conditions either in routine work or in emergency conditions.



**GENERAL PROJECT SPECIFICATION FOR
PROJECT SAFETY REQUIREMENTS**

- Current documentation is available and on location of each Material Safety Data Sheets (MSDS) on all chemicals and hazardous materials to which employees may be exposed and that a system is in place to maintain its currency.
- Contractor must develop a procedure to inventory hazardous materials kept on site that is regularly reviewed.

28.0 FIRE SUPPRESSION EQUIPMENT

Reference Coordination Procedure Section 24, Fire Protection & Fire Fighting.

- Determine the areas that require fire extinguishers.
- Determine the type, size, and number of fire extinguishers needed.
- Locate a vendor to service and re-charge fire extinguishers.
- Ensure all mobile equipment is equipped with a fire extinguisher.

29.0 SAFETY & PERSONNEL PROTECTIVE EQUIPMENT

Contractor shall:

- Identify the quantity and types of personnel protective and safety equipment needed.
- Develop a schedule to ensure the timely delivery of equipment and materials to the project.



GENERAL PROJECT SPECIFICATION FOR
PROJECT SAFETY REQUIREMENTS

30.0 WORK PERMIT REQUIREMENTS

Contractor is required to develop a system that addresses simultaneous operations and interfaces between Contractors working at a common site. Contractors permit system shall incorporate checks and authorizations that are consistent with risk or hazards.

The contractor must ensure the following requirements are developed into the Permit system:

- The work permit system contains prestart checks to ensure that: the work site is safe, that necessary isolations are performed and verified, necessary bypasses are performed, the work does not unsafely interfere with other work in progress or planned, those affected by the work are informed of the work and possible affects upon their work, and appropriate communications and coordination meetings are held and key decisions recorded.
- Work permits are approved for a specific duration.
- Senior operations management is responsible for ensuring an effective work permit system and verifying that it is used correctly.
- The type of work and work conditions that are managed with work permits are defined for each site based on the risks involved.
- Each Work Permit has a description of the work and details specific precautions to protect personnel, environment and equipment from potential hazards.
- Permit procedures require closeout checks to be performed at completion of the work to ensure that: the work was performed satisfactorily, isolations and bypasses are restored, work place and process are returned to a safe condition, and completion of work is communicated to affected personnel.
- The authority to approve and closeout work permits is clearly designated and documented at each site.
- All personnel issuing or using work permits are trained in the application of work permit procedures.
- Work permit system and training effectiveness is audited periodically and results documented. Work permits and records are retained to facilitate this assessment.

Develop project specific work permit procedures complying with Esso Permitting Policies and local requirements.



**GENERAL PROJECT SPECIFICATION FOR
PROJECT SAFETY REQUIREMENTS**

- Lock and Tag
- Cold Work (if required)
- Hot Work
- Confined Space
- Crane Lift
- Field Instrument
- Welding on Live Equipment or Platforms
- Excavations
- Electrical Hot Work
- Suspended Work Baskets

31.0 EMERGENCY PROCEDURES

- Develop project wide evacuation plan in coordination with Esso
- Identify emergency assembly areas and evacuation routes in coordination with Esso
- Develop maps illustrating these areas
- Identify emergency services/equipment that may be required: ambulance, medivac, fire truck, trauma packs, personnel retrieval systems
- Publish a listing of emergency communication systems
- Ensure that numbers are posted in appropriate areas of the project
- Severe weather procedures
- Post designations of assembly areas



GENERAL PROJECT SPECIFICATION FOR
PROJECT SAFETY REQUIREMENTS

32.0 MEDICAL SERVICES

- Establish medical evacuation procedures and determine when to use local or foreign medical facilities based on extent of injury.
- Establish which off-site medical facilities are to be utilized by local employees for job related injuries or illnesses.
- Identify who will conduct employee physicals.

NOTE: Refer to Coordination Procedure Section 23, Occupational Health, Medical Facilities and Sanitation.

33.0 SAFETY INCENTIVE PROGRAMS

Develop programs to recognize employees and crews for superior safety performance.

34.0 SAFETY MEETINGS

Contractor must ensure that adequate meetings are held to proactively address associated hazards. As a minimum the Contractor must:

- Establish weekly safety meetings for all project supervisors.
- Establish an attendance tracking system.
- Establish a weekly Tool Box Meetings for craft.
- All safety meetings must be documented.

35.0 SUB-CONTRACTORS

- All sub-contractors have the same safety requirements as Contractors.
- Develop site specific sub-contractor safety policies and procedures.
- Ensure safety policies/procedures and qualification packages are included in proposals and contracts.

36.0 DISCIPLINARY PROCEDURES

Develop disciplinary procedures to address safety violations that are fair and consistent throughout.



GENERAL PROJECT SPECIFICATION FOR
PROJECT SAFETY REQUIREMENTS

37.0 PROJECT SAFETY GOALS

- Develop project safety goals to include no lost time accidents/injuries.
- Develop project safety objections that include those established by Esso.

38.0 PURPOSE STATEMENT

Provide purpose statement for project stating:

- Management commitment
- Intent, goals and objectives
- Expectation for support from all site personnel

39.0 SAFETY TRAINING

Develop a written and verbal orientation and comprehension test for new employees and sub-contract personnel to include:

- Description of project
- Management commitment
- Project safety goals and philosophy
- Site specific rules
- Evacuation alarms and procedures
- Areas requiring special protective clothing
- Accident and injury reporting procedures
- Permitting procedures
- Disciplinary procedures for safety violations
- Reporting unsafe acts or conditions
- Tool Box Meetings
- Hazard communication
- Chemical screening



GENERAL PROJECT SPECIFICATION FOR
PROJECT SAFETY REQUIREMENTS

40.0 SPECIAL PROJECTS ISSUES

- Identify Safety Training and Comprehension Programs to educate site personnel on applicable safety management programs.
 - Hazard Communication/MSDS
 - Employee Medical Records
 - Confined Space Entry
 - Respiratory Protection/Fit Test
 - Hole Watch
 - Fire Watch
 - Emergency Procedures
 - Opening and Blinding
 - Lock and Tag
 - Process Overviews/Hazards
 - Industrial Hygiene

- Identify Safety Training and Comprehension Programs for craft specific tasks.
 - Basic Rigging/Hand Signals
 - Bloodborne Pathogens and first aid associated with (MSDS)
 - Power Actuated Tools (certification)
 - Electrical safe work practices
 - Fire extinguishers portable
 - Fork Lift Operator
 - Drum handling
 - Compressed gas/cylinder handling
 - Control of hazardous energy
 - Assured equipment grounding
 - Accident prevention signs, tags, barricades
 - Hearing conservation/protection
 - Personal protective equipment
 - Trenching and excavation
 - Welding/cutting/brazing
 - Overhead Gantry Cranes
 - Safe handling and storage of explosives

- Selection of computer programming to be used to track training.

40

41.0

- Required craft certification programs per ~~Esse~~ Accident Prevention Manual
- Powder Power Tools
- Delete reference to a document not provided to the contractors. Correct typographical error



GENERAL PROJECT SPECIFICATION FOR
PROJECT SAFETY REQUIREMENTS

41.0 CRAFT SPECIFIC CERTIFICATION PROGRAMS

- Required craft certification programs.
 - Power Actuated Tools
 - Crane Operator
 - Motorized Equipment/Vehicles
 - Fork Lift Operator
 - Aerial Lift
 - Material and Personnel Hoist

- Develop training programs and comprehension tests for supervisors.
 - Permits
 - General safety responsibility, liability
 - Incident/Accident investigations

42.0 SAFETY AUDITS/INSPECTION PROGRAMS

- Establish weekly audit format.
- Develop auditing schedule.
- Identify site specific inspection programs.



GENERAL PROJECT SPECIFICATION FOR
PROJECT SAFETY REQUIREMENTS - APPENDIX I

APPENDIX I
MONTHLY SAFETY SUMMARY REPORT

(INSTRUCTIONS)

GENERAL

The success of the Esso's Accident Prevention Program can only be determined by developing standard records that collect accurate data. This procedure is detailed in OSHA 29 CFR 1904 (OSHA Record Keeping Guidelines). The data to be collected is described on Form SR-1 "Monthly Safety Summary Report" (Table 1). This information will be catalogued throughout the year on a calendar year basis.

Contractors/Sub-contractors are required to complete and submit the Monthly Safety Summary Report to the Esso safety representative each and every month. This report is due on the 5th workday of each month. It is very important that this information is accurate and on time.

SAFETY SUMMARY REPORT INSTRUCTIONS

Section A: Project Information

1. Enter your assigned project number.
2. Enter the reporting month.
3. Enter Contractor name.
4. Enter Sub-Contractor name.
5. Enter reporting period. Example: FROM 27, July 1996 TO 31, August 1996.



GENERAL PROJECT SPECIFICATION FOR
PROJECT SAFETY REQUIREMENTS APPENDIX I

Section B: Project Site Statistics Craft/Salaried

1. Enter project location.
2. Enter the number of employee workhours for the reporting period (month and year to date).
3. Enter any one-time treatment and subsequent observation of minor work-related scratches, cuts, burns, splinters, etc. not requiring medical care. However, a physician or registered professional may administer the first aid.
4. Enter any work-related loss of consciousness, injury or illness requiring more than first aid treatment by a physician, dentist, surgeon or registered medical personnel, nurse or paramedic under the standing order of a physician.
5. Enter all work-related deaths and illnesses, and those work-related injuries which result in: loss of consciousness, restriction of work or motion, transfer to another job, or require medical treatment beyond first aid.
6. Enter all work related cases resulting in an individual being unable to return to work on any of the individual's scheduled workshifts after the day of injury or illness.
7. Formula for calculating recordable incidence rate is as follows: Take the number of recordable cases x 200,000 ÷ by the number of hours worked. Use this same formula for both month and year to date calculations.
8. Formula for calculating Lost-Time Case incidence rate is as follows: Take the number of Lost-Time Cases x 200,000 ÷ by the number of hours worked. Use this same formula for both month and year to date calculations.
9. Formula for calculating employee hours per doctor case is as follows: Take the number of hours worked ÷ the number of doctor cases. Use this same formula for both month and year to date calculations.



GENERAL PROJECT SPECIFICATION FOR
PROJECT SAFETY REQUIREMENTS APPENDIX I

Section C: Project Site Statistics

1. Enter number of hours since last Lost-Time injury.
2. Enter any business related auto/transportation accident.
3. Enter number of safety meetings held during the reporting period.
4. Enter the number of events that did not cause injury or fatality but that could reasonably have developed into a more serious incident.
5. Enter the number of documented safety walkthroughs conducted during the reporting period.

Section D: Project Site Statistics Approval

1. Signature is required by the individual preparing the document.
2. Enter the date the document was prepared.
3. Signature is required by the project manager in charge or designee.
4. Enter the date of project manager or designee approval.

**ESSO EXPLORATION AND PRODUCTION
CHAD DEVELOPMENT PROJECT
MONTHLY SAFETY SUMMARY REPORT
(TABLE 1)**

SECTION A: CONTRACTORS PROJECT INFORMATION		
(1) PROJECT NO: 06 864000	(2) MONTH:	(3) REPORTING PERIOD FROM:

SECTION B: PROJECT SITE STATISTICS																
Contractor (1)	Employee Hours (2)		First-Aid Cases (3)		Doctor Cases (4)		Recordable Cases (5)		Lost-Time Cases (6)		Incidence Rate Rec. Cases (7)		Incidence Rate Lost-Time Cases (8)		Employee Hours Per Doctor Case (9)	
	Month	YTD	Month	YTD	Month	YTD	Month	YTD	Month	YTD	Month	YTD	Month	YTD	Month	YTD
TOTAL:																

SECTION C: PROJECT SITE STATISTICS	
(1) NUMBER OF HOURS SINCE LAST LOST-TIME INJURY:	(2) CAR/TRAVEL ACCIDENTS:
(3) SAFETY MEETINGS:	(4) NEAR MISS INCIDENCE:

SECTION D: PROJECT STATISTICS APPROVAL			
(1) Prepared by:	(2) Date:	(3) Project Manager or Designee:	(4) Date:

Contractor Project to date hours	
----------------------------------	--

Notes:



GENERAL PROJECT SPECIFICATION FOR
PROJECT SAFETY REQUIREMENTS - APPENDIX II

APPENDIX II

ALCOHOL AND DRUG USE POLICY FOR CONTRACTORS

CONTRACTOR ALCOHOL AND DRUG USE POLICY

General Requirements

It is not ESSO's intent to establish alcohol and drug use policies for Contractors. However, ESSO requires contractors to have and enforce a program which is consistent with providing an alcohol and drug free workplace, which includes appropriate substance abuse testing programs, and is commensurate with the level of risk in the work being performed.

Contractors performing work on ESSO owned or controlled premises, in direct contact with ESSO operations, or of a nature which could cause ESSO to be held responsible for losses suffered as a result of actions on the part of Contractor or its employees, hereby agree to observe the following:

- Prohibit the misuse of legitimate drugs, or the use, possession, distribution, or sale of illicit or unprescribed controlled drugs or paraphernalia.
- Prohibit the possession, use, distribution, or sale of alcoholic beverages while on ESSO owned or controlled property.
- Recognize the right of ESSO to conduct unannounced searches of Contractor's property on ESSO premises.
- Recognize the right of ESSO to require Contractor to remove employees where cause exists to suspect alcohol or drug use.
- Prohibit the use of alcohol in all camp facilities.
- Prohibit Contractor's employees from being unfit for work as a result of the use of alcohol or drugs.
- Test as required by these guidelines.
- Comply with all applicable federal, state, and local laws and regulations.

ESSO EXPLORATION & PRODUCTION CHAD INC.



GENERAL PROJECT SPECIFICATION FOR
PROJECT SAFETY REQUIREMENTS - APPENDIX II

- Contractors are required to pre-access test all security and food service personnel.
- All Expatriates are required to have pre-access alcohol and drug testing prior to arriving on job site.

Categories of Contractor Positions

The following categories of contractor positions are identified for purposes of testing and other requirements under these guidelines:

Safety-Sensitive Contractor Positions

ESSO management will determine those contractor jobs that are safety-sensitive. In general, these jobs have the following characteristics:

- a high exposure to catastrophic operational incident,
- the person performing the job has a direct role in operations where failure could result in serious harm to public or employee well-being, or
- of a nature which could cause ESSO to be held responsible for losses or actions of the Contractor.

Jobs Comparable to Designated Positions

ESSO management will determine those contractor jobs that are comparable to ESSO designated positions. In general, these jobs have the following characteristics:

- a high exposure to a catastrophic operational incident,
- the person performing the job has a direct role in operations where failure could result in serious harm to public or employee well-being, and
- no direct or very limited supervision is available to provide operational checks.



**GENERAL PROJECT SPECIFICATION FOR
PROJECT SAFETY REQUIREMENTS - APPENDIX II**

Jobs Comparable to Specified Executives

Contractor management will determine those Contractor jobs that are comparable to ESSO specified executive positions. In general, these are senior executives of a major company organization or are managers responsible for an organization which also has jobs comparable to designated positions.

Contractor Substance Abuse Testing

The following substance abuse testing requirements shall apply for Contractors working in ESSO operations:

- **Suspicion of Alcohol or Drug Use/For-Cause Testing.** All Contractors will be required to remove any of their employees from performing work for ESSO any time there is suspicion of alcohol or drug use or possession. In addition, for-cause alcohol and drug tests are required after a safety incident where there exists a basis to suspect involvement of alcohol or drug use. In cases involving contractors working in safety-sensitive positions or jobs comparable to designated positions, for-cause alcohol and drug tests are required after any safety incident. In any of the above cases, the Contractor's employee may only be considered for return to work after Contractor certifies as a result of a negative alcohol and drug for-cause test, conducted immediately following the incident, that said employee was in compliance with these guidelines.
- **Pre-Access Testing.** No Contractor employees working in safety-sensitive positions or in jobs comparable to ESSO designated positions will be permitted to perform work for ESSO unless Contractor certifies such employee has passed a pre-access alcohol and drug test within the 12 month period immediately prior to commencing such work. Any category of alcohol and drug test conducted during this period as part of the Contractor's substance abuse program that meets the standards of these guidelines may be used to satisfy this requirement.

ESSO EXPLORATION & PRODUCTION CHAD INC.



GENERAL PROJECT SPECIFICATION FOR
PROJECT SAFETY REQUIREMENTS - APPENDIX II

- Random Testing. Contractors working in jobs comparable to ESSO designated positions, as determined by ESSO, are required to be continuously subject to an unannounced random alcohol and drug testing program while they are performing work for ESSO. Specified executives of contracting firms are encouraged to be subject to the same random alcohol and drug testing program to demonstrate their commitment to a substance-free workplace.

Any employee of a Contractor who tests positive in any of these alcohol and drug tests, or refuses to be tested, must be removed from the ESSO site and any ESSO work.

Test Administration (U.S.)

Alcohol and drug testing will be accomplished in accordance with applicable laws and will be the sole responsibility of the Contractors. While the U.S. Department of Transportation (DOT) requirements for substances to be tested, testing frequency, and threshold levels set acceptable standards, Contractors that do not have an existing program should be strongly encouraged to adopt ESSO's alcohol and drug testing standards. ESSO will not administer any alcohol or drug tests for Contractor's employees. Contractor will be responsible to select a lab certified to conduct such testing under a recognized certification program. Retaining the test results is the responsibility of Contractor.

Test Administration (Non-U.S.)

Alcohol and drug testing will be accomplished in accordance with applicable local/national laws. Contractor should normally be responsible for the testing of its workers. Non-U.S. Contractors that do not have an existing program should be strongly encouraged to adopt ESSO's full panel of drugs, thresholds and testing standards.

Contractor shall submit threshold levels to ESSO for review and approval.

ESSO EXPLORATION & PRODUCTION CHAD INC.



GENERAL PROJECT SPECIFICATION FOR
PROJECT SAFETY REQUIREMENTS - APPENDIX II

Test Administration

Alcohol and drug testing will be accomplished in accordance with applicable laws and will be the sole responsibility of Contractor. ESSO will not administer any drug or alcohol tests for a Contractor's employee. The testing standards to be used insofar as drugs tested for, screening levels, and confirmatory levels, must, at a minimum, meet the U.S. Department of Transportation (DOT) requirements for drugs other than alcohol, and ESSO's requirements for alcohol. In addition, ESSO requires testing that complies with ESSO standards for all drug substances including alcohol for Contractor personnel assigned in positions comparable to ESSO's "designated" positions. DOT and ESSO's standard substances to be tested for and their detection levels are listed in Table 1. Testing may be performed at any certified laboratory. Handling of test results (e.g., retention, release, etc.) is the Contractor's responsibility.

Audit

Contractor is hereby advised that ESSO may, at ESSO's discretion, conduct an unannounced audit of Contractor's drug and alcohol program to verify that:

- Contractor's policy and its enforcement comply with these guidelines.
- Tests are being conducted as required.
- Procedures for handling samples establish a chain of custody that prevents tampering and switching of samples.
- The laboratory being used conducts tests using a scientifically sound method and is certified to perform such tests.
- The use of prescribed drugs is not reported as test positives to management. A medical review of test results is desirable.

Sub-contractors

Contractors must require their sub-contractors to maintain a Drug and Alcohol Policy in keeping with the requirements herein or require them to abide by ESSO's drug and alcohol policy guidelines to the same degree that Contractor must comply.



**GENERAL PROJECT SPECIFICATION FOR
PROJECT SAFETY REQUIREMENTS - APPENDIX II**

Exception

Contractor's employees who are subject to substance abuse testing requirements who are hired on short notice may, at ESSO management discretion, be permitted to begin work pending the required substance abuse testing certification. However, such certification must be received by ESSO with seven (7) calendar days from the first date Contractor's employees commence performing work. This exception does not apply to Contractor designated positions.

Certain other exceptions may be granted by ESSO management and will be handled on a case-by-case basis.

Non-Compliance

If it is determined that a Contractor is not complying with the provisions as described herein, action may be taken by ESSO to remove Contractor from a particular job and to note such non-compliance when considering Contractor for future jobs. The action taken will be at the discretion of ESSO management.

Contractor Designated Positions (refer to the notes on the following page)

At a minimum, Contractor designated positions shall include the Project Manager, Construction Manager, Crane Operators, Aircraft Pilots, Boat Captains and Truck Drivers hauling volatile products. Contractor shall nominate other designated positions that generally fall within the guidelines of the notes on the following page.

Random Testing Guidelines (for designated positions only)

Fifty percent (50%) of Contractor employees who perform work or relieve others who perform work in designated positions must be "random" tested every 12 months. Such testing is in addition to ESSO's requirement that all employees be subject to a pre-employment drug/alcohol test.

ESSO EXPLORATION & PRODUCTION CHAD INC.



GENERAL PROJECT SPECIFICATION FOR
PROJECT SAFETY REQUIREMENTS - APPENDIX II

Note:

The following guidelines should be used to determine if a specific job falls into the designated position category:

1. the position involves work that provides a high exposure to a catastrophic operational incident, or
2. the position involves a direct role in operations, where a failure could result in serious harm to public or employee well-being, or
3. the position involves working either with no or very limited direct ESSO supervision for operational oversight.



GENERAL PROJECT SPECIFICATION FOR
PROJECT SAFETY REQUIREMENTS - APPENDIX III

APPENDIX III
JOB SAFETY ANALYSIS (THE JSA)

What is JSA?

It is a simple procedure used to review a specific workplan in order to uncover hazards and then eliminate or remove them before the work is started.

Why Should We Perform a JSA?

- Develops worker involvement in planning and doing the work in an efficient, safe manner.
- Promotes teamwork and communication.
- Facilitates training.
- Focuses workers on their specific responsibilities.
- Identifies improvements to established job methods.

When is a JSA Performed?

Every time new work is started or a workplan changes.

Who Performs the JSA?

A JSA is performed by a unit of workers, supervisors and inspectors assigned to a specific work activity.

How is a JSA Performed?

Step 1 - Select the work team and then the job to be completed.

Step 2 - Categorize the job into a series of steps.

Step 3 - Identify the hazards associated with each step.

Step 4 - Decide on actions necessary to eliminate, reduce or control a hazard that could lead to an accident.

ESSO EXPLORATION & PRODUCTION CHAD INC.



GENERAL PROJECT SPECIFICATION FOR
PROJECT SAFETY REQUIREMENTS - APPENDIX III

BENEFITS DERIVED FROM THE JSA PROCESS

Direct

- Identifies Hazards
- Improves Safety
- Defines Job Procedures
- Provides Training Commitment
Commitment
- Increases Awareness
- Reduces Accidents
- Ensures OSHA Compliance
- Generates Safety Initiatives
- Facilitates Continuous Improvement
 - Productivity
Important
 - Quality

Indirect

- Builds Teams
- Increases Involvement in Safety Process
- Develops Sense of Ownership
- Demonstrates Management's
- Builds Self-Esteem
- Increases Job Satisfaction
- Empowers those Performing the Work
- Recognizes the Expert
- Encourages Participation
- Shows that each team member is
- Makes Safety More Fun
- Shows Safety is Priority
- Demonstrates that We Care
- Encourages Thinking Before Acting
- Increases Understanding of Expectations *
- Indicates Commitment *
- Provides Exposure to OSHA Standards *
- Identifies Skill Levels *
- Identifies "Safety Leader" in Work Group *

ESSO EXPLORATION & PRODUCTION CHAD INC.



GENERAL PROJECT SPECIFICATION FOR
PROJECT SAFETY REQUIREMENTS - APPENDIX III

* = Specific to Contractors



GENERAL PROJECT SPECIFICATION FOR
PROJECT SAFETY REQUIREMENTS - APPENDIX III

JOB SAFETY ANALYSIS

Purpose: To identify the hazards or potential hazards associated with each step of a particular job and develop actions to eliminate, reduce or control the hazard.

To develop a thought process that can be used even when a written Job Safety Analysis is not performed.

How to Develop a JSA (see sample JSA form attached)

1. Categorize or identify job into observable steps.
2. Identify potential hazards associated with each step.
3. Specify control measures for hazards identified.

Priority of Job Selection for JSA

1. Frequency of job. (Note: Less frequent jobs are normally considered more critical.)
2. Magnitude of job.
3. Potential of accident/injury.
4. Newly established jobs.
5. Jobs requiring procedure modification.

Benefits

1. Reinforces thought process employees should use, whether written or not.
2. Helps plan selected jobs.
3. Helps critique a job.
4. Acts as a training aid for employees in training.
5. Standardizes safe work practices.
6. Perpetuates hazard control awareness.



GENERAL PROJECT SPECIFICATION FOR
PROJECT SAFETY REQUIREMENTS - APPENDIX III

HOW TO COMPLETE A JOB SAFETY ANALYSIS (JSA)

The JSA should be completed in accordance with the following guidelines:

Keep sentences short.

A. Sequence of Basic Job Steps

Categorize job into observable steps. Try not to be too general or too detailed.

- If job is complex, break into several tasks; prepare a JSA for each task.
- Begin with active verb, e.g. disconnect, check, invert, assemble, etc.
- Number each step.

B. Potential Hazards

Identify possible hazards associated with each step. List opposite job step.

- Consider potential accident causes (e.g., strain, sprain, cut, slip, fall, etc.).
- Consider environmental hazards (e.g., vapors, gases, heat, noise, etc.).

C. Recommended Safe Procedure

Develop solutions for each potential hazard. List opposite hazard.

- Present controls (e.g., ventilate, isolate, allow to cool, secure, etc.)

JOB SAFETY ANALYSIS

(Project)	Job: Page of	Date:	New Revised
Title of Person Who Does Job:	Supervisor (Title) Yard Worker	Analysis By:	
Field Location	Safety Manual Rules That Apply	reviewed By:	
Required/Recommended (Circle One) Personal Protective Equipment			Approved By:
A. Sequence of Basic Job Steps	B. Potential Hazards	C. Recommended Safe Procedure	

JOB SAFETY ANALYSIS

	Job: Sharpening & Replacing a Rotary Mower Blade Page of	Date:		New Revised
Job Safety Analysis Training Guide	Title of Person Who Does Job:	Supervisor:	Analysis By: Operator & Supervisor	
Department: Maintenance Group	Section: Outdoor Beautification		Reviewed By: Safety Department	
Required/Recommended (Circle One) Personal Protective Equipment: Cut Resistant Gloves and Safety Glasses			Approved By: Manager	
A. Sequence of Basic Job Steps	B. Potential Hazards		C. Recommended Safe Procedure	
<ol style="list-style-type: none"> 1. Disconnect spark plug wire. 2. Remove Fuel. 3. Invert mower. 4. Remove dull blade. 5. Check for bent blade. 6. Sharpen and balance dull blade. 7. Reassemble blade to mower. 8. return mower to cutting position. 9. reconnect spark plug wire. 10. Add fuel. 	<ol style="list-style-type: none"> 1. Striking against (SA) housing. Burn hand. 2. Spillage - Fire, inhalation. 3. Caught between (CB) Dropping on foot, etc. Spilling fuel. Overexertion. 4. Knuckles SA blades. 5. Cuts while handling blade. 6. Cutting hand, SA vise. 7. SA blade or housing. 8. Overexertion. Caught between 9. None 10. Fire 		<ol style="list-style-type: none"> 1. Do not use excessive force. Allow mower to cool. 2. Ventilation, no smoking, proper container. Flush away with water (if necessary). 3. Tip properly. (Grass catcher chute up). Wear gloves. Be sure cap is tight. Lift properly, use leg muscles. 4. Securely block blade-wooden block. Use proper size SOCKET WRENCH WITH EXTENDER. Wear gloves. 5. Wear gloves. 6. Wear gloves. AVOID CONTACT WITH SHARP BLADE. 7. Block blade. WEAR GLOVES. AVOID CONTACT WITH SHARP BLADE. 8. Use leg muscles, not back. Wear gloves. 9. None 10. Ventilate, no smoking, proper container. 	



GENERAL PROJECT SPECIFICATION FOR
PROJECT SAFETY REQUIREMENTS - APPENDIX IV

APPENDIX IV
HOW TO CONDUCT A ROOT CAUSE ANALYSIS

1. Organize an Investigation Team.
Team should consist of at least:
 - CONTRACTOR's Supervisor
 - CONTRACTOR's Safety Advisor
 - An ESSO's representative
 - Another member of work force (experienced/knowledgeable in process involved)
 - Injured party (if possible)
2. Interview those involved.
Review with interviewees the purpose of Root Cause Analysis:
 - To enable us to take action to prevent a similar occurrence.
 - Root Cause Analysis does not blame people. Investigation Team will review data to uncover the system or process that needs to be corrected.
3. Interview promptly while memories are fresh and not influenced by discussions with others.
 - Team should interview witnesses one at a time. (One-on-one interviews may sometimes be needed, use judgment.)
 - Conduct interviews with minimal interruptions. Ask open-ended questions.
 - Ask questions to clarify. Ensure that witness's account and Team's understanding agree.
 - Encourage witnesses to contact one of the Investigation Team members later if they remember additional facts.
4. Visit accident scene. Collect any physical objects (e.g. tools, clothing, equipment, etc.).
5. Complete pages 1 through 3 of this form.
 - Re-interview if questions arise during this process.
6. Mail completed original form and supplemental photos, sketches, materials, etc., to ESSO.
7. Get concurrence on "Root Actions" from Field Superintendent and enter corrective steps in standard operating procedures.



GENERAL PROJECT SPECIFICATION FOR
PROJECT SAFETY REQUIREMENTS - APPENDIX IV

ROOT CAUSE ANALYSIS

- INJURY: NEAR MISS: PROPERTY DAMAGE: .
- DATE OF EVENT: TIME: a.m./p.m. WORK LOCATION: .
- WEATHER: _
- PERSON INJURED OR NEARLY INJURED: _
- EXTENT OF INJURY: _
- EXACT LOCATION OF EVENT: _
- DESCRIBE WHAT HAPPENED: _

- WHAT TASK DID THE INJURED PERSON PERFORM PRIOR TO THE ACCIDENT/NEAR MISS?

- DAYS WORKED IN FIELD:
- DAYS SINCE LAST DAY OFF:
- HOW MUCH EXPERIENCE DID THIS PERSON HAVE IN THE WORK BEING DONE? .



GENERAL PROJECT SPECIFICATION FOR
PROJECT SAFETY REQUIREMENTS - APPENDIX IV

GETTING TO ROOT CAUSE

Step 1 Use this listing as an aid in identifying the factors that contributed to this event.
Do not be limited by areas listed, add items as needed. Check all that apply.

PROCEDURES

- ___ • None Developed
- ___ • Developed-Not Followed
- ___ • Developed-Not Trained
- ___ • Developed-Not Understood
- ___ • Developed-Not Accurate
- ___ • Developed-Unable to Follow
- ___ • _____
- ___ • _____

IN A HURRY

- ___ • Verbally Implied Need
- ___ • Employee Perceived Need
- ___ • Friendly Competition
- ___ • Due to External Factors
- ___ • Workload too Heavy
- ___ • Lack of Teamwork
- ___ • Taking Shortcuts
- ___ • _____

HAZARD

- ___ • Created by Man
- ___ • Created by External Factors
- ___ • Documented but Not Repaired
- ___ • Unidentified
- ___ • Identified but Accepted
- ___ • Repaired but Deficient Repair
- ___ • Conditions Changed Without Proper
- ___ • Communication
- ___ • Lack of Documentation
- ___ • _____
- ___ • _____

TRAINING

- ___ • Recent Training Provided for Specific Task
- ___ • Circumstances Not Addressed in Training
- ___ • Tool Used Incorrectly
- ___ • _____
- ___ • _____

COMMUNICATION

- ___ • Insufficient Planning
- ___ • Breakdown in Communication Between Workers
- ___ • Breakdown in Communication Between Workers and Supervisor
- ___ • Breakdown in Communication Between Work Teams
- ___ • Confusion After Communication
- ___ • _____
- ___ • _____



GENERAL PROJECT SPECIFICATION FOR
PROJECT SAFETY REQUIREMENTS - APPENDIX IV

Step 1 (Cont'd)

FACILITIES/EQUIPMENT

- Faulty Equipment
- Poor Design
- Corrosion/Wear
- Ergonomic Factors
- _____
- _____

OTHER FACTORS

- Weather/Temperature
- Working Long Hours
- Physical Overexertion
- Personal Protective Equipment
- Improper Body Position
- _____
- _____

Step 2 From areas identified above, choose the major cause:

- Procedures In a Hurry Hazard
- Facilities/Equipment Training Communication
- Other _____

Step 3

Major Root Cause _____
(Identified in Step 2)

- Why did this happen? _____

- Why? _____

- Why? _____

- Why? _____



GENERAL PROJECT SPECIFICATION FOR
PROJECT SAFETY REQUIREMENTS - APPENDIX IV

Step 3 (Cont'd)

- Corrective Steps for Subcauses

- To ensure elimination of hazards identified above, corrective steps handled as follows:

- Added to standard operating procedures?

Yes _____ N/A (explain) _____

- Other follow-up method used (specify)

- Other follow-up method used (specify) _____

WE HAVE REVIEWED THE INFORMATION AND BELIEVE THE ROOT CAUSE HAS BEEN DETERMINED.

INVESTIGATION COMMITTEE:

_____ (Supervisor)
 _____ (Safety Leader)
 _____ (Member)
 _____ (Member)

INJURED PARTY:

_____ (Name)

REPORT REVIEWED

FIELD SUPERVISOR/STAFF MANAGER: _____

OPERATIONS SUPERINTENDENT: _____

OPERATIONS MANAGER: _____

Report received by Safety Coordinator and distributed to other locations.

INITIAL: _____ DATE: _____



GENERAL PROJECT SPECIFICATION FOR
PROJECT SAFETY REQUIREMENTS - APPENDIX V

APPENDIX V
SUB-CONTRACTOR SAFETY QUESTIONNAIRE

Contractor is required to provide ESSO with the detailed information requested below for each sub-contractor, in the format indicated, concerning the sub-contractor's safety performance for approval by ESSO prior to award of sub-contract:

◆ Total Number of Hours worked for each of the last 3 years.

1993 _____ 1994 _____ 1995 _____

◆ Total Number of Employees who worked for your company during each of the last 3 years.

1993 _____ 1994 _____ 1995 _____

◆ Number of Lost Workday Cases incurred at your work sites over the last 3 years.
(Refer to Definitions/Criteria following)

1993 _____ 1994 _____ 1995 _____

◆ Number of Recordable Cases incurred at your work sites over the last 3 years.
(Refer to Definitions/Criteria following)

1993 _____ 1994 _____ 1995 _____

◆ List the Number of Fatalities your company has experienced over the last 3 years.

1993 _____ 1994 _____ 1995 _____

Submit an explanation for each Fatality that occurred along with company's action plan to prevent recurrence.



GENERAL PROJECT SPECIFICATION FOR
PROJECT SAFETY REQUIREMENTS - APPENDIX V

◆List the Number of Safety Violations/Fines your company has received over the past 3 years.

1993 _____ 1994 _____ 1995 _____

Briefly describe the nature of these Violations/Fines, including the jurisdiction/entity imposing them.

◆Does your company have a written Safety and Health Plan?

YES NO

If yes, provide a copy of the Table of Contents of the Plan as part of your response.

◆Does your company incorporate the use of Professional Safety Personnel at your construction job site?

YES NO

Explain their functions within your company.

◆Indicate the frequency of safety meetings conducted by your company.

/per week/per mo./per year



GENERAL PROJECT SPECIFICATION FOR
PROJECT SAFETY REQUIREMENTS - APPENDIX V

Definitions/Criteria Relating to Safety Information Requested:

Lost Workday Case:

These cases are generally the most serious non-fatal injuries and illnesses. They occur when the injured or ill employee experiences days away from the work site as a direct result of a work site injury or illness. In these situations, the injured or ill employee is affected to such an extent that (1) days must be taken off from the job for medical treatment or recuperation; or (2) the employee is unable to perform their normal job duties over a normal work shift. Injuries and illnesses are not considered lost workday cases unless they affect the employee beyond the day of injury or onset of illness.

Recordable Injury:

Recordable injuries are those which involve specific medical treatment, loss of consciousness, restriction of work or motion, or transfer to another job. A work-related injury must involve at least one of these four conditions before it is deemed recordable. Minor injuries requiring only first aid treatment are not recordable.

The following are generally considered medical treatment which involve criteria for a recordable accident:

- Treatment of INFECTION
- Application of ANTISEPTICS during second or subsequent visit to medical personnel
- Treatment of SECOND OR THIRD DEGREE BURN(S)
- Application of SUTURES (stitches)
- Application of BUTTERFLY ADHESIVE DRESSING(S) or STERI STRIP(S) in lieu of sutures
- Removal of FOREIGN BODIES EMBEDDED IN EYE
- Removal of FOREIGN BODIES FROM WOUND: if procedure is COMPLICATED because of depth of embedment, size, or location
- Use of PRESCRIPTION MEDICATIONS (except a single dose administered on first visit for minor injury or discomfort)
- Use of hot or cold SOAKING THERAPY during second or subsequent visit to medical personnel
- Application of hot or cold COMPRESS(ES) during second or subsequent visit to medical personnel
- CUTTING AWAY DEAD SKIN (surgical debridement)



GENERAL PROJECT SPECIFICATION FOR
PROJECT SAFETY REQUIREMENTS - APPENDIX V

- Application of HEAT THERAPY during second or subsequent visit to medical personnel
- Use of WHIRLPOOL BATH THERAPY during second or subsequent visit to medical personnel
- POSITIVE X-RAY DIAGNOSIS (fractures, broken bones, etc.)
- ADMISSION TO A HOSPITAL or equivalent medical facility FOR TREATMENT

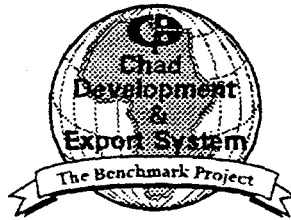
The following are generally considered first aid treatment (e.g., one-time treatment and subsequent observation of minor injuries) and should not be recorded if the work-related injury does not involve loss of consciousness, restriction of work or motion, or transfer to another job:

- Application of ANTISEPTICS during first visit to medical personnel
- Treatment of FIRST DEGREE BURN(S)
- Application of BANDAGE(S) during any visit to medical personnel
- Use of ELASTIC BANDAGE(S) during first visit to medical personnel
- Removal of FOREIGN BODIES NOT EMBEDDED IN EYE if only irrigation is required
- Removal of FOREIGN BODIES FROM WOUND; if procedure is UNCOMPLICATED, and is, for example, by tweezers or other simple technique
- Use of NON-PRESCRIPTION MEDICATIONS AND administration of single dose of PRESCRIPTION MEDICATION on first visit for minor injury or discomfort
- SOAKING THERAPY on initial visit to medical personnel or removal of bandages by SOAKING
- Application of hot or cold COMPRESS(ES) during first visit to medical personnel
- Application of OINTMENTS to abrasions to prevent drying or cracking
- Application of HEAT THERAPY during first visit to medical personnel
- Use of WHIRLPOOL BATH THERAPY during first visit to medical personnel
- NEGATIVE X-RAY DIAGNOSIS
- OBSERVATION of injury during visit to medical personnel

ESSO EXPLORATION & PRODUCTION CHAD INC.



CHAD DEVELOPMENT PROJECT



GENERAL PROJECT SPECIFICATION FOR

HEALTH PLAN

GPS-010

Rev. No.	Date	No. of Pages	Prepared By	Reviewed By	Approved By	Revision Details
0	19 Nov 96	26	CKO	PRS	DJS	Issued for Proposals
1	30 Oct 97	26	MEF	PRS	DJS	Issued for EMP



GENERAL PROJECT SPECIFICATION FOR
HEALTH PLAN

TABLE OF CONTENTS

1. Introduction 4

 1.1. Health Services Delivery / Primary Medical Care 4

 1.2. Public and Environmental Health / Infectious Diseases 5

 1.3. Occupational Health 7

2. Purpose and Requirements of Contractor Health Plan 7

 2.1. Purpose 7

 2.2. Health Plan Requirements 7

 2.3. Contractor Organization and Management of the Health Plan 9

3. Esso Policies 10

4. Health Resources, Roles, and Responsibilities 10

 4.1. Historical Perspective 10

 4.2. Health Care Providers..... 11

 4.2.1. Basic Skills Requirements 11

 4.2.2. Additional Skills Requirements / Roles 11

 4.2.3. Hiring Criteria..... 12

 4.3. Medical Coverage and Service 14

 4.3.1. Medical Care Coverage 14

 4.3.2. On-Site Medical Services..... 15

 4.3.3. Health Clinic at Main Camps..... 15

 4.4. Emergency Response..... 16

 4.5. Reporting Requirements 17

5. Health Facilities 18

 5.1. Mobile Clinics Supporting Pipeline Construction 18

 5.2. Communication Between Camps, Work Sites, and Mobile Clinics..... 18

 5.3. First Aid Equipment..... 19

 5.4. Sick Bay..... 19

6. Preventive Health Measures and Personnel Screening 19

 6.1. Fitness Evaluations..... 19

 6.1.1. Project Staff..... 19

 6.1.2. Catering and Household Staff 20

 6.1.3. Other Specific Employee Groups 20

 6.1.4. Exclusionary Physical Conditions 20

 6.2. Public and Environmental Health Control 21

7. Occupational Health: Chemical and Physical Agent Exposure 22

8. Training..... 24



GENERAL PROJECT SPECIFICATION FOR
HEALTH PLAN

List of Tables

Table 1. Staffing Levels and Camp Size..... 16
Table 2. Potential Chemical and Physical Agent Exposures..... 24
Table 3. Training Areas..... 26
Table 4. Other Frequent Vector-Borne Diseases in West Africa..... II-3

Appendices

Appendix I – Public and Environmental Health Control Program..... I-1
Appendix II – Vector-Borne Diseases Other than Malaria..... II-1
Appendix III – Medical Service Guidelines for Remote Sites..... III-1



GENERAL PROJECT SPECIFICATION FOR
HEALTH PLAN

1. Introduction

The Chad Development and Export System Project presents several potential health risks to the work force. The Project's activities, in turn, may also present potential health risks to the local population. Most of the more serious, non-industrial risks to Project staff and Contractors come from living and operating in a developing country and its tropical environment.

A well-managed health plan working in concert with project safety and management personnel can control risks. Managing project-related risks requires continuous focus on preventing infectious and vector-borne diseases, occupational illnesses and injuries, and public health issues (including environmental sanitation). This specification provides requirements that are to be included in Contractor's Health Plan, as well as guidance on the issues to be considered.

1.1. Health Services Delivery / Primary Medical Care

Although specific health risks are associated with the specific work environment (see Occupational Health) and with operating in an African country (see Public and Environmental Health/Infectious Diseases), persons will need access to routine medical services. This should include provision and delivery of routine day-to-day medical care and assessment, triage and treatment of urgent and emergency care.

Contractor is responsible for providing and delivering routine day-to-day medical care; as well as assessing and treating urgent and emergency cases. Emergency medical risks include serious single and multiple injuries; and severe and complicated, often drug-resistant malaria or other infectious diseases, which require the following in-country capabilities:

- first aid
- specific medical treatment
- possible in-country surgery or intensive care medical treatment at larger, better equipped diagnostic and treatment facilities
- triage
- immediate stabilization
- medical evacuation, as needed⁽¹⁾
- suitably skilled medical personnel

⁽¹⁾ Medevacs are frequently multi-staged and each stage requires unique equipment and skills. For example, initially a patient may be transported by light aircraft and then later by commercial aircraft to complete the evacuation.



GENERAL PROJECT SPECIFICATION FOR
HEALTH PLAN

Contractor must emphasize feasible preventive means, early detection and surveillance, rapid clinical and laboratory diagnosis of disease, and quality first-aid for injury. Advanced medical and rescue team members should respond to emergency medical situations in the field, obtaining stabilization in the field, and then continually assessing dynamic patient parameters from first contact until the patient is:

- treated and released, or
- hospitalized at the camp or an associated larger facility, or
- evacuated to an advanced care center, when appropriate.

A guiding principle is to stabilize the patient (ongoing and frequent reassessment) while arranging efficient medevac contingencies. Weather, aircraft availability, and numerous other factors dictate the need for ensuring that more than one route/method of medevac is available and on stand-by status whenever feasible.

1.2. Public and Environmental Health / Infectious Diseases

Chad and Cameroon are seasonally tropical African environments with limited public health measures for infectious disease control. Persons working or living in Chad and Cameroon may be exposed to serious, life-threatening infectious and vector-borne diseases (such as malaria). Suitable preventive measures require both professional medical attention (industrial hygiene (IH) and public health measures) and individual attention (immunizations; malaria prophylaxis/suppression; food and water; safety/IH precautions).

Contractor is responsible for primary, secondary, and tertiary prevention measures for infectious and communicable diseases that are prevalent in the Project environment. These diseases may be vector-, food-, water- and air-borne intestinal illness; or transmitted from person-to-person.

- Primary prevention is achieved by eliminating the sources of infection (e.g. breeding grounds), preventing transmission or by protecting people from becoming infected (e.g., immunizations). Source and transmission control measures are accomplished through engineering design procedures.
- Secondary prevention is recognizing and treating symptoms early or recognizing other indicators of potential disease based on active screening and medical surveillance programs. Secondary prevention programs reduce the prevalence (baseline) of disease and disability.



GENERAL PROJECT SPECIFICATION FOR
HEALTH PLAN

- Tertiary prevention is early treatment and aggressive medical management of disease to minimize disability and productivity loss.

Appendices I and II present information on many of the vector-borne diseases that are expected in the project environment.

Primary, secondary & tertiary prevention measures for vector-borne diseases should be presented in Contractor's Health Plan. Particular emphasis should be placed on strategies that emphasize primary prevention through engineering design practices particularly in areas such as housing, water supply, sanitation, and construction.

Contractor's approaches and management of infectious and vector-borne diseases should be consistent with the World Health Organization's (WHO's) Panel of Experts on Environmental Management for vector-control (PEEM)

Areas of concern related to construction activities are primarily, but not exclusively, focused on the transportation sector. Specific areas where engineering design practices can have significant impacts on vector-borne diseases are: 1) drainage and construction practices for roads (malaria mosquito breeding sites); 2) design of river and stream crossings affecting stream flow rates (black fly breeding sites); 3) migration of burrowing rodents into temporary labor camps secondary to pipeline construction activities (spread of visceral leishmaniasis and other hemorrhagic fevers); and 4) disturbances of existing mosquito habitat in rainforest environments (yellow fever and other hemorrhagic fevers).

Vector-borne disease transmission rates can also be impacted by activities and behaviors within work camps: 1) use of non-secured water supplies for bathing (bilharzia); 2) contamination of water supplies (diarrheal diseases); 3) contamination of food sources (salmonella, shigella, cholera); and 4) temporary crowding conditions that promote the spread of respiratory disease outbreaks. Minimum requirements for camp facilities and catering services are provided in GPS-001 (Camps and Facilities) and GPS-002 (Catering Services), respectively. Minimum standards for potable water treatment are provided in GPS-003 (Potable Water Treatment, Storage and Distribution (Temporary)).

Finally, Contractor's Health Plan must address sexually transmitted diseases (STDs) such as HIV, chlamydia, chancroid, herpes, gonorrhea and syphilis. Primary, secondary and tertiary prevention strategies for STDs should be clearly presented since the prevention and spread of STDs is an important issue.



GENERAL PROJECT SPECIFICATION FOR
HEALTH PLAN

1.3. Occupational Health

Preventing, controlling, and treating work-related injuries and illnesses is achieved by coordinating industrial hygiene and occupational medicine programs. Occupational and industrial risks come from the nature and complexity of the Project and include workplace accidents, motor vehicle accident-related injuries, and adverse exposures (e.g., noise, dust, heat, fumes). Staff will also reside at construction and operations sites, which presents public health and environmental sanitation issues similar to a small community.

2. Purpose and Requirements of Contractor Health Plan

2.1. Purpose

This Health Plan establishes the criteria and technical basis for designing and implementing Contractor's Health Plan for the Chad Development and Export System Project. This Health Plan specifies the medical and IH components of the Project. Specifications and guidelines are detailed in areas that do not strongly depend on Project designs and execution plans. As the Project becomes more defined and in-country conditions change, this plan may be revised.

The criteria in this Health Plan and the accompanying Appendix III entitled "Medical Service Guidelines for Remote Sites" are intended to help Contractor develop measures to correct known and potential health concerns in and out of the workplace in Chad and Cameroon. Such measures specify medical facilities, equipment, procedures, and indicate the appropriate numbers of suitable medical and IH professionals to staff clinics and to support Contractors, Sub-Contractors, and Esso employees in various Project locations.

2.2. Health Plan Requirements

Contractor's Health Plan shall, at a minimum consist of the following elements:

- Provide and maintain on-site clinical services to include:
 - routine and emergency care
 - medical stabilization and evacuation
 - industrial hygiene
 - first-aid training



GENERAL PROJECT SPECIFICATION FOR
HEALTH PLAN

- medical screening (pre-employment) and medical surveillance protocols
 - immunizations and preventive health
 - community liaison
 - public health including vector-borne and other infectious diseases
 - surgical intervention (in selected remote-site larger operations)
- Comply with all applicable laws and regulations and apply reasonable and responsible standards where laws and regulations do not exist.
 - Ensure food and drinking water sanitation.
 - Develop appropriate programs to educate, assist, advise, and direct appropriate personnel regarding IH and environmental hygiene (e.g., noise, emissions, illness-preventive measures, manual material lifting and sanitation) and document the training.
 - Assess a worker's baseline and ongoing (surveillance) medical fitness for work: Provide appropriate pre-employment medical histories, physical examinations and laboratory testing including evaluating staff health, providing high standards of clinical care and helping staff prevent illness and injury.
 - Vaccinate expatriate and local work force and provide preventive health education and training.
 - Develop and provide infectious and vector control programs, as well as, closely coordinate other medical and safety activities.
 - Respond to emergencies. The physician/medic/IH roles are critical to a site's emergency response plans (including casualties). Contractor shall design, implement, debrief, and critique practice "drills" on a regular basis and after each emergency. Contractor shall communicate the results of this plan regularly.
 - Maintain records and reports for periodic review. This effort should monitor and document effective medical management of employee illnesses and injuries, and systematically monitor the health of the aggregate workforce. The proposed epidemiologic approach for obtaining, analyzing and presenting illness and injury data should be presented. Particular emphasis should be



GENERAL PROJECT SPECIFICATION FOR
HEALTH PLAN

placed on calculation and presentation of baseline prevalence diseases rates, incidence rates and other calculated measures that can be used to demonstrate effectiveness of the overall health program.

- Plan for internal audits to ensure health plan program requirements are followed.
- Provide specific quality assurance/quality control (QA/QC) plans that cover clinical and laboratory medical activities. Particular emphasis should be placed on consistency and clarity of charting and laboratory diagnoses of vector-borne and other infectious diseases.

2.3. Contractor Organization and Management of the Health Plan

Within the context of the policies described in Section 3.0, the Contractor's Health program will be organized and managed to ensure the following:

- Health professionals will be available in appropriate numbers and have the necessary training and skills to deliver the services required.
- Site management will endorse the Health program at each site. Clear organizational responsibilities will ensure that functional and Operations Integrity Management System requirements are met.
- Health interfaces with line management are clearly defined including reports for periodic review.
- Contractor medical and IH organizations have clear lines of communication with Esso's in-country Medical Director.
- Procedures exist to evaluate the quality and appropriateness of Health services and to manage the continuous improvement process.
- Where sound medical management and public health principles dictate, Contractor should coordinate practices, procedures, and record keeping with Esso and other contractors to effectively monitor the health of the overall workforce.



GENERAL PROJECT SPECIFICATION FOR
HEALTH PLAN

3. Esso Policies

Esso's policy is to conduct its business in a manner that protects the health and safety of its employees, others involved in its operations, customers, and the public. Esso Policy Directives will be available upon request.

Contractors and Sub-Contractors shall contractually acknowledge Esso's strong commitment to Health and safety. Their contracts will affirm that they have a written Health and safety policy, which Esso will review and approve prior to mobilization. The Health and safety policy shall be widely disseminated and understood among Contractor and Sub-Contractor staff.

Esso is committed to continuously improving performance throughout its activities. This effort involves a systematic and cyclic approach to implementing Health and IH programs, monitoring effectiveness, analyzing results, and reevaluating and changing policies and procedures as appropriate.

To help Esso achieve its policy goals, Contractor(s) will systematically identify, evaluate, and try to control or eliminate potential health risks associated with Project operations. Contractor shall also comply with the Health Plan requirements stated in Section 2.2.

Achieving these goals will improve health, safety, productivity, and morale among staff; meet business needs; enhance relationships with the communities in which Esso operates; and ensure compliance with legal and regulatory obligations.

4. Health Resources, Roles, and Responsibilities

4.1. Historical Perspective

Historical experience in medically deprived nations elsewhere estimates the following:

- Approximately 65% of national employees will visit the clinic per month.
- Expatriate employees visit a clinic 4 to 6 times a year.
- Camp health care professionals (e.g., doctors, physician assistants, nurses) are expected to assist 30 to 40 patients a day, perhaps more during malarial peaks.



GENERAL PROJECT SPECIFICATION FOR
HEALTH PLAN

The World Health Organization minimum standard is 3 beds per 1,000 person population. Contractor shall propose in his health plan appropriate facilities, based upon work force size.

4.2. Health Care Providers

4.2.1. Basic Skills Requirements

Due to the nature of the work environment, medical personnel should be competent with trauma/emergency medicine, both light and heavy, to address situations such as crushing, multiple injuries, chest and abdominal penetrating wounds, and amputation.

Medical personnel should also be knowledgeable, preferably extensively experienced, in preventing and treating infectious and vector-borne diseases, like malaria. Experience has shown that practitioners who have worked in remote areas (i.e., removed from consultation and nearby specialist care) better handle the daily challenges, difficulties, and frustrations associated with practice in medically under-served countries.

Emotionally stable, physically fit practitioners who have preferably three or more years (minimum) experience in foreign or remote (yet modern and scientifically oriented) practice settings tend to withstand the rigors and relative professional isolation that are typical of overseas work in isolated settings.

4.2.2. Additional Skills Requirements / Roles

In addition to providing primary care and emergency medical services, health care providers may be expected to provide ancillary health services that are not part of a core clinical skill set, but are additional expectations based on Project complexity, and the working and living environment. These skills and capabilities are listed below (not all inclusive) and may provide for optimal usage of the health care provider:

- sick bay management
- first aid training
- monitoring food hygiene



GENERAL PROJECT SPECIFICATION FOR
HEALTH PLAN

- monitoring environmental health
 - water supply monitoring
 - solid waste treatment
 - sanitation
 - disposal of clinical waste
 - control of vector-borne diseases e.g., act as Public and Environmental Health Control Officer

- exposure monitoring / surveillance / education
- disability management
- drug and alcohol policy implementation (per GPS-008)
- industrial hygiene monitoring
- mental health counseling
- health education / promotion
- immunization / chemoprophylaxis
- site emergency response & disaster planning
- administration: record keeping / reporting
- medical supply inventory monitoring
- maintain communication with local medical community
- aid in Exxon-defined community outreach at a later stage
- maintain communication links between on-site and base camp (i.e., telephone / radio / fax/ tele-medicine)

4.2.3. Hiring Criteria

Contractor's Medical Director will be a fully-qualified physician reporting directly to Contractor's Project Manager or equivalent and will regularly communicate with Esso's In-Country Medical Director. The Medical Director will be an expatriate (American- or Western European-trained) and have the following experience and skills (in order of priority):

1. public and environmental health with emphasis on vector-borne and infectious diseases and disease epidemiology
2. primary care (health services delivery) ranging from emergency medicine to routine ambulatory care, and
3. occupational health.



GENERAL PROJECT SPECIFICATION FOR
HEALTH PLAN

Additional candidate qualification for medical director, and for other doctors, physician assistants, nurses, and medics will be submitted to Esso for review and approval. Refer to Appendix III, Section 2.2.2. Basic requirements for each position is as follows:

Medical Director must have good accident and emergency experience, an understanding of occupational health and epidemiology, and a high level knowledge of vector-borne and infectious diseases endemic to the operating area. This senior physician should have solid administrative and communication skills, and be familiar with and maintain relationships with all available medical facilities adjacent to the operating area that could be used for medical referral. This senior physician shall be the medical coordinator and professional supervisor in his area, and be responsible for treatment procedures and any prophylactic measures required for Project staff.

Contractor is expected to have an in-country Medical Director to manage Contractor's Health program.

Physician and Physician Assistant (PA) must have at least five years post-graduate experience and should not be newly qualified. The physician and PA must have experience in accident and emergency, infectious and vector-borne medicine, and occupational health. Additionally, they should have good administrative and communication skills, and be familiar with all available medical facilities adjacent to the operating area that could be used for medical referral.

Licensed Registered Nurse should have previous experience in isolated work settings. Should have recent practical refresher training to include tropical and trauma medicine. Should have direct reporting and accessibility to a doctor or experienced PA. The nurse's qualifications and experience should be professionally assessed, and skills pertinent to the job duties enhanced by regular and required sessions of continuing medical education.

Medics/Paramedics should, at a minimum, be experienced emergency medical technicians (EMT-P) (Paramedic Level), and have highly advanced trauma stabilization and transport skills. Medics/paramedics will routinely teach and must be experienced with extricating accident victims, proper vehicular (ambulance) transport, and, quite often, with helicopter rescue and evacuation. A Trauma PA or physician teamed with an EMT-P are an optimal critical care transport team.



GENERAL PROJECT SPECIFICATION FOR
HEALTH PLAN

IH Coordinator should be a Certified Industrial Hygienist (CIH) or equivalent. During his/her tenure, it is expected that he/she will select a national and sufficiently train that individual to fill the position. Depending on the size and scope of Contractor's work, the IH Coordinator may have other responsibilities.

4.3. Medical Coverage and Service

4.3.1. Medical Care Coverage

At any time, the staff of major Contractors, Sub-Contractors, locally hired staff, and others will be temporarily working on a site operated by someone other than their employer. These individuals must never be denied medical care simply because they are not a direct-hire employee of Contractor managing the site medical facility. Just as rooms and meals are charged back to a worker's employer, medical care will also be equally accessible to any Project employee. The Contractor shall provide, with his detailed medical plan, unit rates for medical services to Project staff other than his own direct-hire staff or Sub-Contractors. Contractor's medical clinic will serve project workers but is not to be a general walk-in clinic for non-project personnel. Eligibility for clinic admission for non-project personnel must be defined with cultural tact.

Project affiliate staff, government personnel working on the site, and Contractor staff are the primary audience for medical care; however the Contractor may also provide care to host country nationals or locals from time-to-time, depending upon the circumstances.

As government negotiations progress, Esso may establish a limited community health outreach program to support preventive health and provide routine clinical services. Although the scope and details of this outreach program are still undefined, and the Contractor should expect his medical personnel to participate to some degree; however, the associated costs with an outreach program should not be considered in the Contractor proposal. The specific outreach program will be consistent with Esso's long-range outreach policy.



GENERAL PROJECT SPECIFICATION FOR
HEALTH PLAN

4.3.2. On-Site Medical Services

During construction, Contractor's medical personnel will serve the various Project sites in both countries. Table 1 should be used to help plan health care provider staffing levels and can be adjusted as camp populations vary. Tele-medical services also can be actively used. Key medical personnel from the Contractor's staff will also have IH contract responsibilities.

On-site medics will be expected to handle primary and emergency care as well as some additional responsibilities as a percentage of their-activities. For additional information, refer to Section 4.2.1 and 4.2.2. All medics and paramedics will report through a doctor and operate according to standing orders or established written protocols. Refer to Appendix III, Section 2.4.2.

Adequate numbers of non-professional personnel trained in first aid procedures provide the first line of medical support. Each work unit that is geographically isolated and working under one supervisor should have an individual trained in basic first aid (e.g., CPR, control of external bleeding, etc.) available within 4 minutes of any person in the work unit. A fully trained first aid responder should be available within 20 minutes of any person in the work unit.

4.3.3. Health Clinic at Main Camps

The Contractor will staff a Health clinic at the Project's main camps. The most senior health care provider will report to Line Management and communicate with Esso's in-country Medical Director. The clinic will provide complete occupational, clinical, public health/infectious diseases and community camp health services as outlined in 4.3.1 and 4.3.2. Contractor will supply resources such as staffing, medical supplies and laboratory and diagnostic equipment (see Appendix III, 2.3.2). Laboratories with "core" capabilities should be part of Contractor health facilities. Diagnostic capabilities will ensure early diagnosis and treatment as well as monitoring/controlling diseases prevalent in the environment.

Contractor should ensure that all health care providers are trained in proper handling of blood and blood-containing products including handling of blood samples and other bodily fluids, sharps, medical waste etc. The contractor should ensure the presence of equipment to properly address these issues.



GENERAL PROJECT SPECIFICATION FOR
HEALTH PLAN

Refer to the E&P Forum "Guidelines for the Control of Blood Borne Pathogens in the E&P Industry."

Table 1. Staffing Levels and Camp Size

Camp Population	On-Site Medical Staff ^{*Δ}		
	Paramedic	P.A., Nurse, or Physician	Sr. Physician
1-50	0	*1	0
50-100	2	*1	0
100-200	3	**1	0
200-500	4	**2	0
500-1,000	5	**3	0
1,000-2,000	6	6	1
2,000-3,000	12	9	1
>3,000	18	12	1
* If a nurse fills the position, he/she should report to an M.D.			
** Recommended minimum of one physician in this situation			
Δ Requirements can be modified in locations where telemedicine can be actively used, (requires Esso approval)			

4.4. Emergency Response

The Exxon Medicine and Environmental Health Department issues an "Occupational Health Emergency Response Planning Guide" that addresses the medical and IH aspects of emergency response and evacuation. This Guide includes planning, communications, casualty handling, exposure assessment, and training. When Project designs, execution plans, and organizational procedures are more fully developed, the Contractor will write project-specific response plans built upon this foundation.

Medical emergency response will vary by location. Medical evacuation will be implemented as needed, using portable medical units and stretchers placed aboard existing aircraft and vehicles, which can be converted for medical service. Patients will be brought to the nearest main camp triage or treatment site, where the decision will be made whether to evacuate from the country (expatriate) or to a local facility (national). Esso's senior medical personnel will be informed of medical evacuations from any Project site in either country.



GENERAL PROJECT SPECIFICATION FOR
HEALTH PLAN

All vehicles more than 30 to 45 minutes from an airstrip should be fitted for and carry an emergency stretcher. Long-term charter aircraft should be able to handle emergency stretchers as part of their basic design. Also, Contractor shall provide lighting on airstrips for emergency flights (local technology includes use of oil-soaked toilet paper rolls in coffee cans, which light well even in rain). Contractor must also provide immediate access to radio communications.

For logistics of medical evaluations, initial stabilization will be in-country either at the site, base camp, or in N'djamena as indicated. If tertiary care is needed, transportation to a local tertiary care facility (for nationals) or evacuation to Europe (for expatriates) will be arranged.

From an IH perspective, emergency response will most probably address crude oil and field chemical spills. Due to the toxic nature of the materials, the industrial hygienist will need to work closely with the emergency response team to address scenarios. Specific topics to consider would include:

- Determining the number and type of clean-up workers and specialized IH equipment.
- Identifying appropriate training materials and a system to train uneducated workers who may not speak English or French.
- Defining personal protective equipment needs.
- Planning for portable change-house, shower, and laundry facilities.

Note: Contractor must provide a method for prioritizing and addressing concurrent medical emergencies and also ensure that postponed medical and IH activities are rescheduled for completion.

4.5. Reporting Requirements

It is expected that Esso will develop standard health reporting forms to effectively monitor the health of the workforce and to help target medical response measures where needed on a project-wide basis. Esso requires that Contractor(s) report the following information:



GENERAL PROJECT SPECIFICATION FOR
HEALTH PLAN

- **Medical**
 - Morbidity and mortality
 - Laboratory statistics
 - Clinic/health-unit usage (numbers and types of cases)
 - Disease control and treatment program (status, problems)
 - Routine medical examinations (numbers, types, exposure-related indices)
 - Medical evacuation

- **Industrial Hygiene**
 - Site audits/reviews
 - Exposure assessments and exposure monitoring results
 - Laboratory statistics
 - Training activity report

5. Health Facilities

5.1. Mobile Clinics Supporting Pipeline Construction

Mobile clinics supporting the road upgrade operation crews shall be staffed per Table 1 and supplied to be self-sufficient and capable of handling emergency trauma in a remote location consistent with Esso guidelines. In addition to first aid boxes, eye wash bottles, and/or appropriate, emergency showers should also be located at key sites in the work area.

5.2. Communication Between Camps, Work Sites, and Mobile Clinics

A reliable means of voice and fax data transfer capability is required, to enable doctors, medics, and other emergency personnel to communicate between the base camp, outlying work sites, fly camps, and other mobile-based health providers.

An adequate number of multi-channel, sturdy hand-held ground-to-ground units will greatly enhance medical rescue efforts. Esso intends to provide, as part of its overall project support, a reliable telecommunications system to provide the basis for the above discussed capabilities at each of the project locations. Contractors will be required to furnish their own hand-held and vehicle communications units consistent with Esso specifications, which are available upon request.



GENERAL PROJECT SPECIFICATION FOR
HEALTH PLAN

5.3. First Aid Equipment

Contractor shall provide first aid equipment for each independent crew or camp location for personnel who are trained in basic level first aid. If a medic or doctor (with equipment) is not on-site or available in less than 5 to 10 minutes, Contractor must provide larger first aid kits at intermediate-sized camps. Kits and first aid equipment must be consistent with the attached specification and provided in quantities sufficient to provide immediate access to the relevant first aid responders discussed in Section 4.3.2. Also refer to Appendix III, Section 2.3.2 (b).

5.4. Sick Bay

Based on the number of employees served and supported, the base camp should be furnished with a sick bay. Details are addressed in Appendix III, Section 2.3.2 (a).

6. Preventive Health Measures and Personnel Screening

6.1. Fitness Evaluations

6.1.1. Project Staff

Contractor shall not hire unhealthy workers (including catering and household staff workers). If treatable problems are found (e.g., certain parasites), the applicant may reapply after treatment. All applicants, including short-term workers shall be free of infectious diseases which may affect others (e.g., active tuberculosis, intestinal parasites, contagious gastrointestinal illnesses, other infectious diseases), and free of acute or chronic diseases that cannot be adequately managed at a work site.

Applicants will be disqualified from employment if deemed physically unfit for the job being applied for, but exclusions must conform with applicable local regulations. Also excluded are those workers unwilling or medically unable to 1) receive or tolerate necessary immunizations for yellow fever, or 2) follow prescribed prophylaxis/preventive measures for malaria as appropriate.

All workers must have a documented minimal medical questionnaire and physical exam performed by a competent nurse, P.A., or M.D. Documentation should include basic lab tests to determine fitness for work and absence of communicable disease; drug and alcohol tests; and a blood



GENERAL PROJECT SPECIFICATION FOR
HEALTH PLAN

pressure measurement. Third-party employment Contractors must apply the same screening standards, with an emphasis on detecting infectious diseases.

Contractors shall screen potential staff for active current and chronic diseases (including selective drug and alcohol testing per the Principal Document), which may prevent workers from performing their assigned work duties, may cause disease in others, or which cannot be adequately managed medically at the work location.

Workers returning for repeat employment after a hiatus of non-employment or extended leave will be subject to similar, but perhaps limited, re-examination and orientation. Contractor shall administer appropriate immunizations, public and environmental health control guidelines, and malaria preventives.

6.1.2. Catering and Household Staff

In addition to the requirements of section, 6.1.1, Contractor will examine catering and household staff at an approved clinic. Contractor must perform exams on catering staff according to the Catering Services Specification, GPS-002.

Catering and household staff workers shall be trained in personal hygiene and food/water handling techniques that minimize the spread of disease to those whom they serve. Additional guidance is provided in the Catering Services Specification, GPS-002.

6.1.3. Other Specific Employee Groups

Other specific employee groups such as drivers (car, bus, truck), crane operators, fire-fighters and wearers of Respiratory Protective Equipment shall be examined as set out in the E&P Forum "Health Assessment of Fitness to Work in the E&P Industry", paragraph 3, and annex 1.

6.1.4. Exclusionary Physical Conditions

Potential staff can be considered unfit for duty if they have an underlying condition which:

- prevents them from meeting the job requirements,



GENERAL PROJECT SPECIFICATION FOR
HEALTH PLAN

- makes them a health hazard to co-workers (e.g., infectious or communicable diseases), or
- cannot be adequately managed medically at the work location.

Examples of such conditions or diseases are:

- Active or military tuberculosis,
- Splenomegaly at risk for trauma,
- Untreated large open abscesses or any evidence of untreated leprosy,
- Extensive and undiagnosed skin rashes and other widespread dermatoses,
- Active, untreated STDs and advanced syphilis,
- Chronic heart or lung disease,
- Inguinal, abdominal, or femoral herniae, especially for jobs requiring lifting,
- Overt psychosis and other debilitating neuropsychiatric illness, and
- Other non-specified conditions which will, in the examiner's judgment hinder effective job performance.

6.2. Public and Environmental Health Control

Malaria is present in most of sub-Saharan Africa, including Chad and Cameroon, and is caused by the bite of an infected anopheline mosquito. All malaria can cause illness, but the falciparum variety in these regions kills many people annually. However, early diagnosis and prompt treatment will usually result in early recovery without complications.

Esso experience indicates that the number of malaria cases can be significantly reduced by implementing a complete Public and Environmental Health Control program. Contractor shall institute a Public and Environmental Health Control program consistent with Esso policy, the key features of which are described below. Due to the number of infectious and vector-borne diseases endemic in the project environment, specific control programs should be developed for each of the major



GENERAL PROJECT SPECIFICATION FOR
HEALTH PLAN

infectious and vector-borne diseases. While measures for malaria/vector control will also help control other insect vector-borne diseases, these are subtle but important differences in prevention strategies to these diseases and Contractor should present sufficient information and detail so that its approach can be evaluated by Esso.

The five key components of a Public and Environmental Health Control program include (where malaria is used as an example):

- Implementing a Public and Environmental Health Control Program
- Protecting personnel:
 - Avoiding mosquitoes and mosquito bites
 - Malaria prophylaxis
- Environmental and engineering design controls:
 - Environmental control of malaria vectors (e.g., vector eradication/mosquito spraying)
 - Engineering design to eliminate breeding sites
- Training in the above measures
- Obtaining skills in diagnosis and treatment

Refer to Appendix I for additional information on a Public and Environmental Health Control program.

7. Occupational Health: Chemical and Physical Agent Exposure

Chemical and physical hazards may cause sickness, impaired health, or significant discomfort. Chemical hazards include excessive airborne concentrations of mists, vapors, gases, dusts, or fumes. In addition to the potential hazard of inhalation exposure, many materials may be irritating or corrosive to the skin or eyes or can be absorbed through the skin in toxic amounts. Physical hazards include excessive levels of electromagnetic, non-ionizing and ionizing radiation, noise, vibration, and extreme temperature and pressure. Ergonomic hazards include lifting of excessive weights or exerting excessive forces.



GENERAL PROJECT SPECIFICATION FOR
HEALTH PLAN

Contractor's Hazard Recognition Program must first identify potentially hazardous locations, substances, and activities. A generic overview of potential chemical and physical hazards associated with the various project phases is listed in Table 2.

As the Project becomes more clearly defined, Contractor's industrial hygienist or equivalent health professional shall expand this table to address specific chemical and physical agents, and the various work groups that may be exposed. Material Safety Data Sheets (MSDS), or equivalent, should be collected for each material used at each site and made available to staff. The Contractor can then evaluate potential exposures and monitor these exposures to confirm these assessments. Health risk assessments will be conducted based on this information.

Contractor shall avoid unnecessary exposures to chemical and physical agents and where feasible, replace toxic chemicals with non-toxic or less toxic alternatives. In situations where exposures may exceed the recommended health standards, the Contractor shall implement methods for exposure control such as engineering controls, administrative controls, and personal protective equipment (listed in order of preference).

Workers will be screened for signs, symptoms, injuries and/or illnesses as a result of potential over-exposure. Affected workers will be removed from exposure and treated appropriately. Prior to returning to work, their fitness for work will be reassessed.



GENERAL PROJECT SPECIFICATION FOR
HEALTH PLAN

Table 2. Potential Chemical and Physical Agent Exposures

- Abrasive Blasting
- Air Conditioning chemicals
- Benzene
- Biological Aerosols
- Carbon Monoxide
- Carpentry Dust
- Confined Space Entry
- Combustion Engine Exhaust Gases (CO, NOx)
- Crude Oil/PNA
- Diesel Fuel/Gasoline
- Drilling Muds/Concerns:
 - Acids/Caustics
 - Biocides
 - Mid-Distillates
 - Silica
- Divers Diseases
- Ergonomics, Human Factors
 - Biochemical
 - Control Room Design
 - Shift Work
 - Lighting
 - Manual Material Handling
 - Valve Control Design
- Heat Stress
- Hospital/Clinic Chemicals
- Hydrazine
- Hydrogen Sulfide
- Laboratory Chemicals
- Laundry Chemicals
- Lead
- Lighting
- Maintenance Chemicals (all types)
- Medical Waste
- Noise
- Paint Pigment/Solvent, Coatings
- Pesticides/Herbicides/Biocides
- Process Chemicals
- Radiation
- Road/Ground Dust
- Sanitation
- Sewage Treatment Chemicals
- Solder
- Sports Facility Chemicals
- Water Supply Chemicals
- Welding Fumes/UV
- Workover Fluids

8. Training

A draft Health training outline is provided in Table 3. Topics were identified based on review of potential risks and the belief that emphasizing these topics would help prevent or mitigate health problems.

Communication is the cornerstone of an effective health program. Contractor's communication programs shall include orientations, injury prevention strategies, and education programs:

- **Orientations** shall address health risks, medical resources at work locations, and personal preventive measures recommended for good health, and emphasize infectious and vector-borne disease prophylaxis, including infectious diseases of food, water, and sexual origin. Orientations shall be given prior to project assignment and/or upon immediate arrival at a work site. Disease



GENERAL PROJECT SPECIFICATION FOR
HEALTH PLAN

prevention shall emphasize continuing immunizations, worker orientation, health promotion, and active, site-based medical and IH programs.

- **Injury prevention strategies**, in addition to traditional safety measures, shall emphasize safe driving habits, fatigue or jet-lag impact on work, environmental stress (heat), and the potential for blood-borne disease if requiring unscreened blood in remote sites after road accidents.
- **Education** shall address all prevalent vector-, food-, and water-borne diseases, including malaria (prophylaxis, personal protection, early symptoms, use of treated bednets/clothing, home leave precautions); food and water precautions; blood-borne pathogens; environmental risks; risks of abuse of alcohol and drugs; snakes of concern; and swimming habits.

Staff education sessions shall also address the prevention of sexually transmitted diseases (STDs), including HIV. Condoms and signage regarding STD prevention shall be available. Contractor's Health Plan shall provide medications for worker STDs that are treatable, thereby reducing the number of active, treatable STD cases in the population. Active STD prevention is associated with a decrease in AIDS case rates. Project contractors, including trucking/transportation contractors, shall be required to implement STD education programs aimed at reducing the transmission and spread of the diseases.



GENERAL PROJECT SPECIFICATION FOR
HEALTH PLAN

Table 3. Training Areas

Health Services and Delivery Training	Comments
First Aid <ul style="list-style-type: none"> • Basic First Aid Course • Advanced First Aid Course 	All Project staff. One individual in every work crew.
Public Health & Infectious Diseases Training	Comments
Public & Environmental Health Control <ul style="list-style-type: none"> • Personal Protection • Site Vector Control Measures 	By Contractor medical staff or Public and Environmental Health Control Officer. For all personnel. For personnel in charge of camp operations.
Disease Risk/Control <ul style="list-style-type: none"> • Tropical Disease Precautions • Food/Water Precautions • AIDS/Sexual Diseases • Women's and Children's Health • Preparing Catering Staff • Preparing Household Staff 	By Public and Environmental Health Control Officer or Contractor medical staff. Training for all personnel. Focus on prevention and recognition. Emphasis on daily activities. Risk and prevention focus. Special needs considerations. Proper procedures to safeguard health. Refer to Appendix I. Proper procedures to safeguard health. Refer to Appendix I.
Sanitation <ul style="list-style-type: none"> • General Hygiene • Food Handling • Water/Waste • Medical Waste 	Overview. For food handling Contractors/medical overseers. For site engineers. Includes drinking water, waste water sanitation and solid waste For medical personnel.
Occupational Health Training	Comments
IH for Design Engineers	Course to train key design engineers about industrial hygiene and human factors design consideration.
Specific Chemical Hazards	Based on risk assessment findings.
PNA Hazard	For workers potentially exposed to crude oil.
Heat Stress	General health issue. Training for all personnel.
Industrial Hygiene <ul style="list-style-type: none"> • Operations Overviews/Expectations • Basic IH Training Course • Noise • Manual Material Lifting 	For IH Contractor specialists. For IH Contacts by the IH Coordinator. For all personnel For all personnel
Bloodborn Pathogens	For all health care providers. Must cover safe handling of blood and potentially blood containing products.



GENERAL PROJECT SPECIFICATION FOR
HEALTH PLAN - APPENDIX I

Appendix I – Public and Environmental Health Control Program

From the Contractor's medical staff, a health care provider who is trained and experienced in infectious diseases and vector-borne diseases and their control shall manage the Public and Environmental Health Control program. Approaches should be consistent with WHO's Panel of Experts on Environmental Management for Vector Control (PEEM). The Public and Environmental Health Control Officer will perform the following services:

- identify and monitor environmental and behavioral risk factors predisposing to infectious and other endemic vector-borne diseases.
- establish procedures and routines for vector-control operations within the camps and direct larviciding, spraying, and other environmental control measures to reduce vector populations.
- be familiar with the qualities and toxicology of chemical insecticides and larvacides, their proper usage, safe handling and storage. The Public and Environmental Health Control Officer must approve any and all chemical vector control agents prior to their purchase or use on site.
- implement routine inspections of camp facilities and potential vector breeding sites to confirm the effectiveness of vector-control operations. Baseline and periodic data should be obtained so that numeric measures of effectiveness are presented.
- maintain detailed records of vector-control activities.
- provide training and technical supervision of local personnel who will use deltamethrin or permethrin to permeate mosquito nets, protective curtains, and clothing.
- conduct formal and informal sessions with crews and staff members to ensure awareness of malaria risk factors and personal protective measures.
- help communicate policy regarding chemoprophylaxis.
- be skilled in diagnosing prevalent infectious and vector-borne diseases based on clinical features and appropriate diagnostic testing either performed by himself or other health care providers.



GENERAL PROJECT SPECIFICATION FOR
HEALTH PLAN - APPENDIX I

- support other medical staff in their efforts regarding epidemiological tracking of infectious and vector-borne disease cases. The Public and Environmental Health Control Officer must direct the protocols, data collection, and database entries for this purpose. Data should be obtained and analyzed in a form that is consistent with the WHO's Panel of Experts on Environmental Management for Vector control (PEEM).
- compile a monthly (and project end) report summarizing the following information and submit the report to the Esso Medical Director:
 - fever cases, and suspected and confirmed cases of malaria and other infectious and vector-borne diseases,
 - relationship of these cases to environmental parameters and personal protection measures (including chemoprophylaxis) employed, and
 - utility of vector control and health education activities employed.

EXAMPLE OF MALARIA CONTROL PROGRAM

Personal Protection for Malaria

Personal protection can be categorized into activities, both of which are important and should be started prior to arrival of Contractor personnel in Chad/Cameroon.

Avoiding Mosquitoes and Mosquito Bites

Project personnel will be expected to comply with the following avoidance strategies:

- *Use mosquito repellents containing approximately 30% DEET.* Repellents should be applied regularly. If arriving via plane during highest risk periods of dusk until dawn, apply repellent prior to arrival. Maintain the routine during the evening and at night particularly when working outdoors.
- *Be aware of damp cool areas where mosquitoes rest.* Externally located shower areas are always damp and are ideal places for mosquitoes to bite unclothed bodies. Repellent should be applied immediately after



GENERAL PROJECT SPECIFICATION FOR
HEALTH PLAN - APPENDIX I

showering in the evening hours. Accumulated water such as puddles, buckets, and old tires are excellent mosquito breeding areas.

- *Be aware that some common mosquito control methods are not reliable. "Knock down" sprays "bug bombs" and mosquito coils have an immediate, but temporary effect, in reducing the number of flying mosquitoes. These methods should not be relied on in preference to other described measures.*
- *Because mosquitoes are attracted to dark colors, clothing shall be light colored and consist of long pants and long sleeves. These measures are particularly important in the dawn-to-dusk hours.*
- *Clothing should be permeated with permethrin (Peripel[®] 55 or deltamethrin insecticide) before arrival or soon thereafter. Deltamethrin is non-toxic to humans, but will repel or kill insects. Also permeate bed nets, door coverings, and curtains with this insecticide.*

Malaria Prophylaxis

It is critical that all expatriate personnel faithfully take malaria medication to prevent malaria. The current recommendation from the medical department for malaria prophylaxis to Esso expatriate personnel is as follows:

- First choice: Mefloquine (250 mg/week)

Note: Mefloquine should not be taken without doctor's advise by people on medication and/or with certain heart conditions, high blood pressure, a history of convulsions or psychiatric problems. The use of Mefloquine should be discouraged for persons whose job requires a high degree of fine motor skills or with a history of side effects to Mefloquine.

- Alternate choice: Chloroquine (500 mg/week) with proguanil (200 mg/day)

Note: While proguanil is not available on the U.S. market, it is easily obtainable in pharmacies in Africa and Europe.

Each of the above-mentioned drugs is available under various trade names. Current recommendations for Chad/Cameroon should be obtained from Contractor medical advisors.



GENERAL PROJECT SPECIFICATION FOR
HEALTH PLAN - APPENDIX I

Vector Control

Environmental control means controlling specific insect vectors to reduce the risk of their contacting workers and causing infection. The vector of concern with malaria is the *Anopheles* mosquito. Killing all biting insects in the greater region of an operating area is not possible particularly during rainy seasons. Such measures are localized to operating sites and immediate surrounding areas.

Environmental Control of Malaria Vectors

- Ditches, drains, and depressions in or near camp sites that are capable of holding water for more than 4 or 5 days should be inspected for mosquito larvae or pupae. If found:
 - small depressions should be filled with dirt,
 - drainage areas that flow into rivers or streams that the local population uses or are natural habitats for fish and/or other animals should be treated with Altosid™ pellets at the rate of one pound per acre (non-toxic to man, animals, and fish; these pellets reduce the risk to workers),
 - water that drains into waste water pits and/or swamps and will not be reused should be treated.
- Laundry and shower areas are ideal resting locations for adult mosquitoes and should be sprayed with deltamethrin, Chem Rez-25™, or similarly approved insecticide every 3 days. Workers assigned to spraying should be specially trained and certified in using the equipment and these agents, and given the necessary safety equipment (rubber gloves and cone masks).
- “Knock down” sprays should be used only for cockroaches and other nuisance insects, but are unreliable as a malaria-control method and may constitute a minor health risk in tightly closed areas. Moreover, using knockdown sprays can provide a false sense of security.
- Routine adulticiding (killing adult mosquitoes) using area-wide sprayers is not effective or cost efficient, except for true widespread outbreaks of disease or insect populations. However, selective hand spraying, using permethrin or other approved agents, should be performed



GENERAL PROJECT SPECIFICATION FOR
HEALTH PLAN - APPENDIX I

approximately every 3 days at camp entry points and areas where moisture routinely gathers, to kill any vectors resting at those sites.

Environmental Control of Some Non-Mosquito Vectors

For insects other than mosquitoes, avoidance is best. An individual using protective clothing and a face net (like a beekeeper uses) should kill stinging insects using Chem Rez-25™, deltamethrin, or approved insecticide in a hand sprayer. After the insects have been destroyed, all nests should be removed and burned.

All food, vegetable, and fruit refuse should be incinerated and the ash placed in the landfill. Traps for filth flies should be placed between the garbage pit and the camp site and emptied weekly.

Training

Training is necessary to develop individual commitment to program principles of personal protection and to understand the rationale for other program components. Training needs to occur often and at different times in multiple locations. Typically, the Public and Environmental Health Control Officer, in consultation with the supervising doctor, will coordinate such training. Their medical staff and the appropriate site managers will also help conduct training.

Esso is committed to minimizing Esso and Contractor staff exposure to malaria. So, Esso has developed substantial Public and Environmental Health Control training and educational materials. Project health, safety, and environmental personnel will work with the Contractor(s) to ensure comprehensive malaria training and control programs exist for their expatriate and national staff prior to mobilization.

Diagnostic Methods and Treatment for Malaria

In the field, Contractor should primarily use QBC® technology to diagnose malaria early. This technology helps to rapidly determine the presence of malaria. Medical staff training is not complicated. All field clinics should have this equipment on site or nearby. Basically, equipment consists of a special blood centrifuge and ordinary microscope with a special light.

Field doctors should understand malaria treatment methods, which consist primarily of oral or intravenous derivatives of quinine. With early diagnosis, treatment is effective.



GENERAL PROJECT SPECIFICATION FOR
HEALTH PLAN - APPENDIX II

Appendix II – Vector-Borne Diseases Other than Malaria

As with malaria, controlling the vectors of other diseases depends upon an awareness of the vector's life history, biting habits, and preferred breeding habitats. The WHO's PEEM Series of publications should be consulted. The following generalizations concern the vectors of other diseases found in the drilling areas of Chad.

Filariasis (Elephantiasis): Mosquitoes of the genus *Anopheles* can carry filariasis, but those of the genus *Culex* are also major vectors. Unlike *Anopheles*, *Culex* breeds in stagnant, muddy pools and even in water contaminated with animal and human waste. It bites indoors or outdoors; its wings are not spotted; it does not stand on its head while feeding. The *Culex* vector of filariasis in Chad bites at night.

Arboviruses (Arthropod-Borne Viruses): Chad mosquitoes transmit a number of viruses that cause human illness. These viruses have interesting names like Chikungunya and O'Nyong Nyong Fever. The *Anopheles* and *Culex* mosquitoes spread these viruses as discussed above. Mosquitoes of the genus *Aedes*, transmit three arthropod-borne viruses: Ä yellow fever, dengue, and Rift Valley fever Ä. *Aedes* mosquitoes bite in the daytime, have white bands on their legs, and breed in natural or man-made containers such as hollow tree stumps, tin cans, and water storage jars.

Onchocerciasis (River Blindness): Black flies transmit small worms which cause this disease. Black flies are tiny gnats ("no-see-ums") that often appear as clouds of insects. They bite with a vengeance unexpected in one so small. Black flies are day biters that breed in fast running, turbulent water such as in rapids, dam spillways, and waterfalls. Unfortunately, they are strong fliers despite their size and can be found many miles from their breeding places. Repellents and clothing are the only practical deterrents if their breeding sites cannot be found and treated with insecticides. Periodic treatment with the drug ivermectin is now being used to prevent local people in affected areas from developing the serious consequences of the disease, particularly blindness.

Leishmaniasis: Sand flies carry this disease which can cause skin sores and chronic liver infection. Like black flies, they are tiny and vicious biters. They breed in animal burrows, termite mounds, and cracks in dwelling walls. They bite at night and can be avoided by the use of insecticide-impregnated mosquito nets.



GENERAL PROJECT SPECIFICATION FOR
HEALTH PLAN - APENDIX II

Trypanosomiasis (Sleeping Sickness): Tsetse flies transmit this disease, which is responsible for the chronic symptoms described by its name. These large flies, uncommon in the drilling area, breed in the ground along stream beds, often at the base of trees. The female produces only one offspring at a time, and the tsetse populations are not usually large. They actually pursue their prey and may follow cars for miles. Both males and females are strong biters. They are not as sensitive to repellents as most other insects. If they are in the area, they cannot be ignored. Swatting is often the only deterrent. If they are encountered on a regular basis, special, very effective traps can be used to reduce their numbers.

Schistosomiasis (Bilharziasis): This disease, which can cause bladder, kidney, or liver damage, is caused by small worms that live in the blood vessels of infected people. Infection is acquired when swimming, bathing, or even wading in bodies of fresh water (e.g., lakes and stagnant ponds). The parasite is transmitted through the unbroken skin during contact with water that contains the small, freshwater snail vectors. Chemicals exist that can kill the snails if necessary, but the best approach is to avoid contact with any natural bodies of fresh water.

Dracunculiasis (Guinea Worm Disease): This disease is acquired by drinking from wells and local water sources that are contaminated with infected water fleas called cyclops. After a human swallows this contaminated water, it takes nearly one year for the larvae to develop into fully grown worms that live just below the skin surface. When mature, the worm, now nearly three feet long, causes a sore to develop, usually on the leg or ankle, and the worm emerges through it over a period of weeks, releasing more offspring into the water where the person seeks relief. The emerging worm may cause nearly total incapacitation. Treating village water supplies with chemicals, filtering the water, and avoiding contact between the water and an individual with an emerging worm are methods of combating Guinea worm disease. Drilling crews can avoid infection by only drinking water from the camp's deep wells.

Hemorrhagic Fevers (Lassa Fever): A variety of hemorrhagic viral fevers are potentially present in the project environment, particularly in rainforest environments. The animal/insect reservoirs for these diseases are not fully known. These diseases can produce symptoms ranging from mild (headache, nausea) to severe (uncontrolled bleeding). Preventive strategies and rigorous surveillance efforts are critical.



GENERAL PROJECT SPECIFICATION FOR
HEALTH PLAN - APENDIX II

**Table 4. Summary of Vectors and Controls for Selected
Vector-Borne Diseases in West Africa**

Disease	Vector	Exposure Risk	Exposure Control	Treatment
Onchocerciasis (river blindness)	black fly	fast-flowing rivers	larvicide sprays	Ivermectin
Loa Loa (filariasis)	deer fly	day exposure in S. Cameroon	light clothes	Diethylcarbamazine
Trypanosomiasis	tsetse fly	rivers, water holes, dry season, rural areas, day biter, bright- colored clothing, moving vehicles	dull-colored, heavy-weight clothing, window screens on vehicles, mosquito netting for day-time resting	Pentamidine
Schistosomiasis (Bilharzia)	snails	fresh standing water	no bathing, in case of contact: rapid toweling	Praziquantel

Publications from the WHO PEEM will be useful to Contractor when planning control measures for vector-borne diseases. Three such publications are:

- Guidelines for Cost-effective Analysis of Vector Control (1993)
- Guidelines for the Incorporation of Health Safeguards into Irrigation Projects through Intersectoral Cooperation, with special reference to the vector-borne diseases (1991)
- Guidelines for Forecasting the Vector-borne Disease Implications of Water Resources Development (1991)

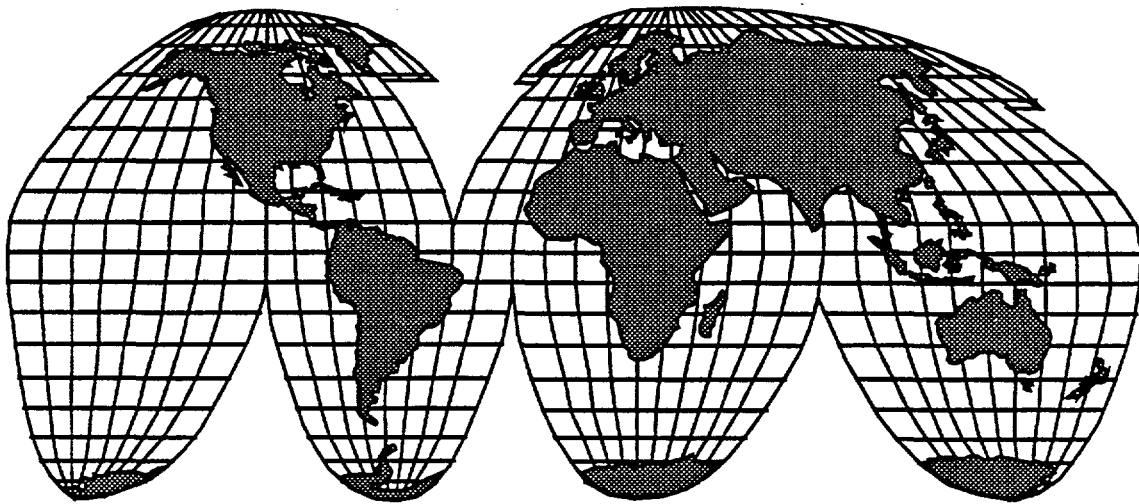


GENERAL PROJECT SPECIFICATION FOR
HEALTH PLAN - APPENDIX III

Appendix III – Medical Service Guidelines for Remote Sites

Refer to the "Medical Service Guidelines for Remote Sites" on the following pages. Note that the following document was prepared for Esso physicians developing risk-based, operation-specific recommendations regarding the level of on-site health care. Contractor should use this document as a guide to do the same and to help it develop measures to correct known and potential health concerns in and out of the workplace in Chad and Cameroon. References to Esso physicians' responsibilities, in the attached document, will not apply to Contractor's relationship to Esso on this project, except as otherwise defined by the Job Specification (e.g., interactions with Esso's Medical Director). Contractor will need to specify its own equivalent of the "Esso physician" in its own Health Plan.

MEDICAL SERVICE GUIDELINES FOR REMOTE SITES



ESSO EXPLORATION & PRODUCTION CHAD INC.

chad development project



MEDICAL SERVICE GUIDELINES FOR REMOTE SITES

TABLE OF CONTENTS

1.0 MANAGEMENT SUMMARY	III- 5
2.0 MEDICAL SERVICE GUIDELINES	III- 6
2.1 INTRODUCTION	III- 6
2.1.1 Definition	III- 6
2.1.2 Purpose	III- 6
2.1.3 Objective	III- 6
2.1.4 Rationale	III- 6
2.1.5 Implementation	III- 7
2.2 PERSONNEL	III- 8
2.2.1 Qualification of the Health Care Provider (HCP)	III- 8
2.2.2 Experience and Credentials	III- 8
2.2.3 Critical Skills	III- 9
2.2.4 Duties and Responsibilities	III- 13
2.3 FACILITIES AND EQUIPMENT	III- 17
2.3.1 Facilities	III- 17
2.3.2 Drugs and Equipment	III- 18
a. Sick Bay	III- 18
b. Dispersed Sites	III- 18
2.3.3 Organization and Management	III- 19
a. Maintenance of Facility	III- 19
b. Access by Patients	III- 19
c. Maintenance of Equipment	III- 19
d. Inventory Control	III- 20
e. Controlled Drugs	III- 20
2.3.4 Transportation	III- 20
a. Ambulance	III- 21
b. Helicopter/Fixed Wing Aircraft or Boat	III- 21
2.3.5 Communication	III- 21
a. Telephone/Fax Machine	III- 21
b. Radio Communication	III- 22
2.4 PROCEDURES	III- 22
2.4.1 Medical Evacuation	III- 22
a. Management of Medical Problems at Remote Sites	III- 22
b. Indications for Medical Evacuation	III- 22
c. Transportation Issues	III- 23
d. Procedures to be Followed by the HCP:	III- 23
e. Medical Escorts	III- 23



MEDICAL SERVICE GUIDELINES FOR REMOTE SITES

f. Reception	III- 24
g. Assessment of Fitness for Duty	III- 24
2.4.2 Standard Operating Procedures/Protocols	III- 25
a. General Protocols	III- 25
b. Specific Protocols	III- 25
c. Reference Materials	III- 27
2.4.3 Administration	III- 27
a. Working Relationships	III- 27
b. Documentation and Medical Record Keeping	III- 29
c. Inventory of Supplies	III- 32
d. Checklists	III- 32

3.0 APPENDICES

I. RECOMMENDED SICK BAY LAYOUT.....	III-33
II. RECOMMENDED LIST OF DRUGS AND EQUIPMENT.....	III-34
III. EXAMPLES OF OCCUPATIONAL HEALTH CHECKLISTS.....	III-49
IV. ALCOHOL AND DRUG SPECIMEN COLLECTION PROCEDURES....	III-

54



MEDICAL SERVICE GUIDELINES FOR REMOTE SITES

1.0 MANAGEMENT SUMMARY

The *Medical Service Guidelines for Remote Sites* document is intended to help Esso(1) continue to meet the challenges of remote site health care delivery in a manner consistent with our priority on safety and health. The guidelines were prepared for typical remote onshore or offshore operations but should serve as a framework to assist Esso physicians in developing risk-based, operation-specific recommendations regarding the level of on-site health care. The output may be used to offer guidance to third party medical service providers regarding the expected level of on-site care and can also serve as the basis for conducting professional evaluations of established operations to help insure consistency of care.

As Esso continues to explore new venture business opportunities in remote, less developed frontier regions of the world, the challenge of maintaining our high safety and health standards is increased. The risks of illness and injury in such operations may be greater due to occupational and environmental factors and/or local endemic diseases. Site health assessments may reveal that acceptable medical resources are either unavailable or at a sufficient distance from remote onshore or offshore operations to limit timely delivery of routine and emergency medical care to the workforce. As a consequence, Esso has directly or indirectly supplemented site-based medical services in all of our remote operating locations where the level of support from existing resources is deemed to be unsatisfactory. The level of care and services in these locations varies, in part because the needs of individual operations vary. In areas where Esso directly provides medical support, the level of care is consistently high. In locations where medical support is coordinated and delivered by a third party, care may be less consistent. Medical care guidelines have been drafted to clarify Esso's expectations regarding essential on-site services and thereby establish greater consistency among remote operations.

The *Medical Service Guidelines for Remote Sites* covers three broad support areas: personnel, facilities and equipment, and procedures. There are three classes of medical personnel required to deliver remote site medical care. In addition to the on-site health care provider (HCP), whose qualifications, skills, and responsibilities are detailed in the service standards; there are also defined roles for an external consulting physician and the Esso physician responsible for advising the operation. These individuals are expected to provide clinical advice, guidance, and oversight to the HCP from an off-site location. The physical facilities and critical equipment which should be available for use by the on-site HCP are described in the service guidelines. In addition, expectations regarding organization and operation of the clinical facility are also defined. General procedures and guidelines for conducting medical evacuations are described along with



MEDICAL SERVICE GUIDELINES FOR REMOTE SITES

categories of medical conditions for which the HCP should possess and follow a set of standard operating protocols. Finally, there is a set of general administrative procedures to guide the HCP on working relationships, documentation, reporting, and inventory

control. The appendices contain suggested floor plans for a sick bay, recommended medication and equipment lists, and samples of forms and checklists to assist the HCP.

(1)The use of the name "Esso" in these guidelines shall include Esso and its affiliates.

2.0 MEDICAL SERVICE GUIDELINES

2.1 INTRODUCTION

2.1.1 Definition

Medical Service Guidelines refer to a set of professionally defined requirements for medical personnel, facilities, equipment, and operating procedures in high occupational risk locations to help insure that acceptable routine and emergency medical services are available to promote and maintain a healthy workforce.

Remote Sites refer to any industrial sites operated by Esso or its affiliates, characterized by the possible absence of acceptable medical support in close enough proximity to a workforce at potentially high occupational risk to provide routine and life-saving emergency medical services.

2.1.2 Purpose

The *Medical Service Guidelines for Remote Sites* is intended for use by Esso and its affiliate venture operations to offer general guidance to third party medical service providers regarding the expected level of on-site care.

2.1.3 Objective

Medical service guidelines provide a basis for helping to insure that Esso's primary emphasis on health and safety can be addressed systematically and consistently in all operations.

2.1.4 Rationale

Safety and health are the highest priority in Esso operations. Prompt diagnosis and



MEDICAL SERVICE GUIDELINES FOR REMOTE SITES

treatment of illnesses and injuries, and ready access to critical life support services are expected in all operating locations. Providing a range of on-site health services at remote sites helps to improve the outcome of more serious medical problems, prevent minor problems from becoming more serious through early intervention, and reduce productivity loss due to illness and injury.

The need for medical service guidelines in higher risk remote operating sites is driven by the following factors:

- a. Medical services in lesser developed regions of the world may vary in quality and accessibility. Medical service limitations may be compounded by inconsistent training and experience of medical personnel, scarcity of equipment and supplies, and poor maintenance capabilities.
- b. Travel time may be extended and unpredictable (> 1 hour) between the operational site and the nearest acceptable medical facilities due to long distance, poor transportation-related infrastructure and weather.
- c. Environmental risk factors which include extremes of climate (e.g. prolonged winter, monsoon, drought) and variable community/public health practices (e.g. poor sanitation, inadequate supplies of safe water) may exist.
- d. In tropical regions, serious infectious disease with rapid courses (e.g. malaria) is not uncommon.
- e. Local health care regulations and social/political factors may be responsible for differences in cultural beliefs/practices and expectations about medical care and services, particularly between the non-national/expatriate workers and the local nationals.
- f. Preventive/occupational health practices may be non-existent or a low priority for many lesser-developed local health care systems.

2.1.5 Implementation

The planning and implementation of remote site support services must be carried out in close cooperation with the Esso or affiliate physician advising the operation. Such physician will provide general recommendations regarding requirements for medical personnel, facilities, equipment, and procedures based on knowledge of operational plans and the outcome of previously conducted medical and health risk assessments in the operational area. The guidelines are for a typical remote onshore or offshore operation but may be modified, as appropriate, by the Esso or



MEDICAL SERVICE GUIDELINES FOR REMOTE SITES

affiliate physician advising the operation.

The *Medical Service Guidelines for Remote Sites* should aid in the selection of third party service providers at the start-up of an operation by helping to insure that vendors are bidding to deliver a comparable set of services. The guidelines will also serve as the basis for conducting professional audits of established operations to help to insure consistency of care. Critical deficiencies and areas for improvement can be identified and selectively targeted for appropriate remediation; thereby, minimizing the need to consider more costly vendor changes during ongoing operations.

The guidelines may be appended in part or whole as an exhibit to the vendor contract. Where appropriate, the vendor may be asked to attest that services will be provided in a manner consistent with the guidelines or any previously agreed to exceptions.

2.2 PERSONNEL

Three classes of medical personnel should be ready and able to provide uninterrupted services to the entire remote site workforce on a 24-hour per day, on-call basis, throughout the period of higher risk operations:

Esso Physician Advising the Operation - Esso physician or affiliate medical director with concurrence from Esso's medical department provides general recommendations regarding requirements for medical personnel, facilities, equipment, and procedures based on knowledge of operational plans and the outcome of previously conducted community medical and health risk assessments in the operational area.

Health Care Provider (HCP) - located in the field and provides day-to-day clinical services to remote site workforce, including routine and emergency medical care.

Consulting Physician - provides day-to-day clinical support and guidance to on-site HCP, including standard operating protocols, case specific clinical management advice, and professional performance assessment and feedback (this support may be from an off-site location by acceptable communication linkage)..

2.2.1 Qualification of the Health Care Provider (HCP)

The number and type of HCPs required to deliver medical services at the remote site will depend upon the number of expatriate and national staff employed; the area over which operations will be carried out; the local health care capability; the



MEDICAL SERVICE GUIDELINES FOR REMOTE SITES

time/distance for medical evacuation; and the health risks associated with the particular occupational and environmental hazards at the remote location.

HCP should possess appropriate and up-to-date qualification/license as a recognized health care provider (e.g. licensed physician, nurse practitioner, physician's assistant, or paramedic). The choice of HCP should be determined by Esso physician advising the operation.

2.2.2 Experience and Credentials

HCP should possess and present evidence of the following:

- a. Current certification in Advanced Cardiac Life Support (ACLS), Basic Trauma Life Support (BTLS) or equivalent critical life support training.
- b. Experience working in an Accident and Emergency Unit or equivalent.
- c. Recent relevant occupational experience (e.g. offshore or other industrial field location).
- d. Good communication and organizational skills. Ability to communicate in local/national languages in addition to English, is advantageous.
- e. Basic computer skills. Ability to record and report outcome and utilization information, and track inventory.
- f. Medical fitness for a remote location and ability to comply with any required remote location training or induction program, including pre-entry alcohol and drug testing.
- g. Ability to demonstrate positive motivation and to work unsupervised or singly.
- h. Further specialized training and experience in tropical medicine/infectious disease is required.

2.2.3 Critical Skills

HCP should possess the critical skills required to deliver emergency and routine medical care. HCP must be able to manage serious illness and injury at the remote location, as appropriate, prior to evacuation for further evaluation/treatment at an acceptable medical facility. HCP must have sufficient training and experience to manage the more common routine medical problems at the remote location, as



MEDICAL SERVICE GUIDELINES FOR REMOTE SITES

appropriate, in consultation with an external consulting physician.

a. General Medical Management

Any illness or injury managed in the remote location will require the HCP to perform an appropriate clinical assessment, provide proper treatment, and thereafter, continue with periodic assessment and monitoring of the patient until full recovery or until care is transferred to another provider with equal or greater qualifications.



MEDICAL SERVICE GUIDELINES FOR REMOTE SITES

(1) Clinical Assessment

HCP must be able to take a relevant clinical history, perform a complete physical examination and conduct simple bedside tests to ascertain the diagnosis (e.g. QBC test for malaria, urine dipstick testing, etc.).

(2) Medication Therapy

HCP must have knowledge and experience with use of non-prescription-as well as common prescription medication, including indications, dosage, duration, route of administration, side effects, toxicity and precautions.

b. **Serious Illness and Injury Management**

In any hazardous operating location, there may be a risk of life threatening accidental traumatic injury and burns. The risk of unexpected medical emergencies becomes a greater concern when increased numbers of individuals of varying age, background, experience and fitness visit or inhabit the remote worksite. Acute and/or chronic pre-existing medical problems, including; seizures, diabetic coma, acute psychosis, anaphylaxis, and cardio-pulmonary arrest, may be present as life threatening conditions requiring prompt medical intervention.

(1) Advanced Life Support

HCP must have training and experience equivalent to Advanced Cardiac Life Support and Basic Trauma Life Support. HCP must be familiar with the procedures, medication, and equipment required to provide advanced life support in the event of serious trauma, shock, or cardiac arrest, including:

- medication therapy (e.g. cardio-pressors, oxygen, narcotic analgesics)
- peripheral and central venous line (external jugular) placement
- airway management, including endotracheal intubation, and crico-thyroidotomy
- use of a monitor-defibrillator and external pacer
- application of pneumatic anti-shock garment
- use of extrication and orthopedic/spinal stabilizing devices

(2) EKG Interpretation

HCP must be able to perform a 12 lead EKG, interpret changes consistent with common cardiac rhythm abnormalities, acute injury patterns, and provide prompt and appropriate treatment of life threatening conditions, when necessary.



MEDICAL SERVICE GUIDELINES FOR REMOTE SITES



MEDICAL SERVICE GUIDELINES FOR REMOTE SITES

(3) Intravenous Therapy

HCP must have training and experience in placing peripheral intravenous lines and administering infusions of systemic antibiotics (for infections) and colloid/crystalloid solutions (to counteract hypovolemic states due to bleeding, burns, severe diarrhea or vomiting). Central venous line placement should be limited to the external jugular when necessary, to minimize risk of complications.

(4) Management of Soft Tissue Injury and Fractures

HCP must have training and experience in extensive wound care and management including proper anesthetic techniques, cleansing, debridement, suturing, and bandaging. HCP should be able to appropriately stabilize and

manage simple and long bone fractures, and institute proper spinal immobilization in cases of suspected cervical or other spinal injury.

c. Common Illness and Injury Management

A range of common problems can be expected to occur in an otherwise healthy working population. The incidence of such problems may be influenced by such factors as: the nature of the work, the level of environmental stress (e.g. climate, altitude, light-dark cycles), proper adherence to site sanitation and hygiene standards, or as a result of close person to person contact. Such conditions usually resolve quickly if recognized and treated early in their course. Individuals suffering from such conditions may be temporarily unfit for usual duty.

(1) Minor Trauma and Wound Management

HCP must have training and experience in simple trauma and wound management (e.g. minor lacerations, minor burns, sprains, simple incision and drainage) including proper anesthetic techniques, cleansing, debridement, and sterile closure using simple sutures and/or bandaging. HCP must be able to recognize and treat latent wound infections and remove old sutures, when appropriate.

(2) Common Illnesses

HCP must have training and experience in the diagnosis and management of common illnesses of the skin, eyes, ears, nose, throat, respiratory, gastrointestinal, cardiovascular and genito-urinary systems. HCP must



MEDICAL SERVICE GUIDELINES FOR REMOTE SITES

understand relationship of illness with ability to perform usual duties and recommend appropriate restrictions. HCP must understand the usual course of common illnesses and discuss conditions which worsen or do not resolve within the expected period of time with an external consulting physician.

(3) Dental Care

HCP must have training and experience in the provision of limited routine dental care; particularly in management of common problems (e.g. caries, extraction) and stabilization of more serious problems (e.g. abscess, maxillofacial trauma) pending referral.

(4) Local Environmental Health Risks and Endemic Diseases

HCP should have knowledge and experience to recognize, prevent, and treat, as appropriate, medical problems which may be unique to the operational area such as:

- adverse reactions to climate, vegetation, insect and other vectors (e.g. heat stroke, sunburn, hypothermia, frostbite, hypersensitivity reactions to plants, stings, and venom);
- diseases transmitted by insects and other vectors (e.g. malaria, Japanese B encephalitis, dengue fever, etc.);
- local public health and hygiene practices (e.g. gastrointestinal diseases related to food and water contamination, sexually transmitted diseases).

d. **Illness and Injury Prevention**

The incidence of medical problems related to accidents and ignorance can be reduced by: raising hazard awareness, providing specific training, instituting the use of preventive devices and procedures, encouraging healthy behavioral and lifestyle changes, and conducting systematic inspections for unsafe or unhealthy conditions.

(1) Health Promotion

HCP must have some training and experience related to public health and understand the importance of health promotion and illness and injury prevention at the remote worksite. HCP must be able to integrate preventive services into the normal course of medical support duties (e.g. health promotion programs, first aid and CPR training/refreshers for supervisors, and immunization updates, if required).



MEDICAL SERVICE GUIDELINES FOR REMOTE SITES

(2) Site Inspection

HCP must have experience conducting systematic worksite inspections to evaluate new occupational health and hygiene concerns (e.g. catering, sanitation, vector control) to assure that all activities and operations which may impact health are in compliance with accepted standards. HCP must produce reports in accordance with local management requests.

2.2.4 Duties and Responsibilities

a. General Responsibility

The HCP will be responsible to the local remote site management for:

- Delivery of quality non-emergency and emergency medical care to all personnel at the worksite.
- Ensuring that personal conduct and appearance meet the highest professional standards at all times.

- Bringing to attention of the local management all matters relevant to the health and well-being of the workforce with appropriate respect for individual privacy and medical confidentiality.
- Producing regular reports on clinic utilization, accidents and injuries, and site health and hygiene inspections.

b. Specific Duties

The specific duties include:

(1) Emergency Care

HCP is responsible for:

- Assessment and immediate treatment of serious illness or injury.
- Liaison with best available local medical personnel, for emergency support and resources, if required.
- Requesting medical evacuation of ill or injured personnel, when necessary (see 2.4.1).

(2) Primary Care



MEDICAL SERVICE GUIDELINES FOR REMOTE SITES

HCP is responsible for:

- Providing clinic access and service for minor illness or injury including assessment, treatment, and regular follow-up of all cases until complete resolution.
- Ensuring appropriate referral of cases which have not resolved as expected.
- Keeping a detailed and factual medical record of all cases seen including diagnosis, treatment given, and final disposition, and applying appropriate confidentiality to the record.

(3) Sick Bay Management

HCP is responsible for:

- Maintaining the sick bay in a clean and tidy state of readiness at all times.
- Providing day-to-day operation and organization of the sick bay.
- Ensuring that all medical equipment is in working order and properly maintained.
- Monitoring inventory of medications and other supplies.
- Maintaining and storing of all documentation and records related to the provision of medical services, including patient records.
- Maintaining a controlled drug register in compliance with applicable laws and regulations.

(4) First Aid Training

HCP is responsible for:

- Coordinating first aid training or refreshers for designated personnel to ensure their knowledge and skills are maintained at an appropriate level.
- Arranging for periodic simulated exercises and drills for first aid personnel.
- Ensuring that first aid equipment (e.g. eye wash bottles, emergency showers, first aid boxes, etc.) is maintained and checked on a regular basis.

(5) Food Hygiene

HCP is responsible for:

- Advising local management on matters relating to food hygiene which include food handling and storage.
- Ensuring food supplies, storage and preparation meet accepted standards



MEDICAL SERVICE GUIDELINES FOR REMOTE SITES

- (e.g. temperatures).
- Carrying out periodic audits (e.g. weekly) of the kitchen and mess areas with appropriate reporting to local management and catering staff.
 - Ensuring that all food handlers are medically fit for duty (e.g. absence of acute or chronic illness).
 - Alerting local management about any outbreaks of gastrointestinal illness that may be related to food or water.



MEDICAL SERVICE GUIDELINES FOR REMOTE SITES

(6) Environmental Health

HCP is responsible for:

- Periodic sampling of potable and other water supplies to ensure compliance with accepted standards (e.g. residual chlorine).
- Conducting periodic inspections (e.g. monthly) to ensure that proper sanitation and solid waste treatment practices are being followed.
- Ensuring appropriate disposal of clinical waste in compliance with applicable laws and regulation.
- Ensuring, in conjunction with local management, that appropriate control measures for vector-borne diseases (e.g. malaria) and/or zoonoses (e.g. rabies) are in place.

(7) Occupational Health

HCP is responsible for:

- Alerting local management about occupational materials or processes which may be hazardous to health.
- Assisting with company-sponsored health surveillance programs for employees who are exposed to specific hazards.
- Investigating, under the direction of local management, suspected occupational illnesses and injuries.
- Educating the workforce about health hazards and the proper use of personal protective clothing and equipment.

(8) Drug and Alcohol Policy

HCP is responsible for:

- Collection of urine and/or blood specimens from employees or prospective employees in accordance with the procedures set forth in the Company Alcohol and Drug Use Policy (see Appendix IV - Alcohol and Drug Testing Collection Procedures).

(9) Industrial Hygiene

HCP is responsible for:

- Assisting local management and safety personnel in the measurement and monitoring of occupational health risks (e.g. noise monitoring) under guidance



MEDICAL SERVICE GUIDELINES FOR REMOTE SITES

of the Esso physician advising the operation.



MEDICAL SERVICE GUIDELINES FOR REMOTE SITES

(10) Counseling

HCP is responsible for:

- Offering counseling services (within his/her skill levels) to employees, and protecting confidentiality as appropriate.
- Ensuring onward referral, where appropriate, of employees with emotional or adjustment problems that may affect fitness for duty or workplace safety.

(11) Health Education and Health Promotion

HCP is responsible for:

- Advising employees on general matters relevant to their health and well-being.
- Presenting information to employees on healthy lifestyle (alcohol, drugs, smoking, diet, weight control, exercise, etc.) or other health-related topics (blood pressure, cholesterol and heart disease, communicable diseases, etc.).

(12) Immunization/Chemoprophylaxis Program

HCP is responsible for:

- Ensuring that appropriate immunization/chemoprophylaxis recommendations are understood and implemented by the workforce, as required (e.g. immunization for Hepatitis B, prophylactic medication for malaria).

(13) Disaster Planning

HCP is responsible for:

- Understanding role in site emergency response and disaster plan.
- Ensuring that an area for triage and multiple casualties is identified.
- Ensuring that critical medical supplies and equipment are pre-packed and available for emergency use at dispersed sites or during patient transport.
- Participating in simulation exercises organized by local management.

(14) Administration

HCP is responsible for:

- Ensuring an effective and organized delivery of medical services through a



MEDICAL SERVICE GUIDELINES FOR REMOTE SITES

- self-audit program.
- Securing and protecting confidential medical information.
- Maintaining inventory control and security, and arranging for resupply at appropriate intervals.

- Tracking and reporting data on clinic utilization and hygiene inspections.
- Recording occupational illnesses and injuries in accordance with applicable laws and regulations and with local management guidance.
- Assisting local management on appropriate non-medical tasks, upon request, at those times when not engaged in clinically-related activities.

2.3 FACILITIES AND EQUIPMENT

The following general specifications for facilities, medication and equipment are recommended for delivery of health and medical services in remote locations.

2.3.1 Facilities

The remote site clinical facility should include a sick bay with designated areas for consultation, physical examination, simple/basic laboratory tests, storage of supplies, in-patient bed(s), toilet and shower. The actual design and size of the set-up will vary based upon the particular health risks at the location and the number of covered personnel. Sleeping quarters for HCP should be in close proximity to the sickbay.

A typical sick bay layout, as shown in Appendix I, should include:

- a. Hot and cold potable water supply.
- b. Adequate work surfaces, laboratory space and cupboard for safe and efficient storage of equipment and medication.
- c. Clean consultation and treatment/procedures room with an examination table and chair.
- d. Sheltered waiting area.
- e. In-patient bed(s).
- f. Toilet and shower.
- g. Adequate room lighting and proper overhead/portable examination light.
- h. Emergency lighting/backup power.
- i. Climate control and adequate ventilation.
- j. Lockable cabinet for storage of medical records.
- k. Lockable cabinet for medication storage.
- l. Lockable refrigerator to keep certain medications and vaccines.
- m. Telephone, fax and radio communication.



MEDICAL SERVICE GUIDELINES FOR REMOTE SITES

- n. Environmental protection (e.g. sun shades, proper insulation). It should also be sealed from penetration by insects/vermin.
- o. Easy accessibility to all patients (e.g. central location, stretcher/wheelchair access).
- p. Adequate patient privacy.

2.3.2 Drugs and Equipment

a. Sick Bay

The minimal equipment required in the sick bay will be similar for any remote location; however, the quantity of available medications and supplies will depend upon:

- Number of personnel at the work location
- Distance from the nearest acceptable medical facilities
- Frequency and time required for resupply

Suggested lists of medications and equipment are included in Appendix II. These medications should include cardiac preparations, antibiotics, antiemetics, analgesics/anti-inflammatories, muscle relaxants, antihistamines, decongestants, steroids, bronchodilators, analeptics, topicals, ophthalmologicals, otorhinolaryngologicals, intravenous solution and miscellaneous items. The soft goods package should include dressings, bandages, suture materials, respiratory, orthopedic, dental, intravenous and miscellaneous items. Anti-malarials will be required.

b. Dispersed Sites

Illness or injury may arise at work locations at some distance from the sick bay (e.g. fly camps). Consideration should be given to locating some critical items of equipment at pre-determined sites, taking into account:

- Size of installation/work area.
- Layout of installation/work area and time/distance from sickbay.
- Number of personnel working in different locations and nature of work being performed.

First aid boxes, eye wash bottles, and, as appropriate, emergency showers should also be located at key sites in the work area and should be:

- Clearly identified.



MEDICAL SERVICE GUIDELINES FOR REMOTE SITES

- Regularly checked by the HCP or designated person.

First aid boxes should contain the following items:

- Individually wrapped bandages.
- Eye pads with attachments.
- Individually wrapped triangular bandages.
- Sterile unmedicated wound dressings.

2.3.3 Organization and Management

The HCP must be familiar with the field operation and work with local management to ensure smooth and efficient operation of the medical facilities.

a. Maintenance of Facility

The HCP must ensure that:

- The sick bay is maintained in a clean and tidy state of readiness at all times.
- Arrangements are made for the cleaning/disinfecting of floors and toilet facilities on a twice daily basis and at additional times as required.
- All working surfaces are thoroughly cleaned on a daily basis and after each treatment as appropriate (e.g. to control blood borne pathogens).
- Appropriate arrangements are made for the laundering of sick bay linen.
- Arrangements are made for the regular disposal of garbage.
- Disposal of contaminated material is carried out in accordance with applicable laws and regulations and in an appropriate manner so as to control blood borne pathogens.
- "Sharps" are stored in a specific container designed to receive such consumables safely and disposal is in accordance with applicable laws and regulations and company procedures (e.g. to control blood borne pathogens).
- Any defects in the fabric, heating, lighting or ventilation of the sick bay are brought to the attention of local management immediately.
- Medical items are properly kept/secured at all times to prevent unauthorized access/ use.

b. Access by Patients

- The sick bay should be clearly identified for the benefit of all personnel.
- The HCP should hold regular clinic hours at appropriate times taking into account shift patterns and ensure that all employees are aware of these times.



MEDICAL SERVICE GUIDELINES FOR REMOTE SITES

- The HCP should be available for service 24 hours a day by radio or beeper and ensure that all personnel are aware of procedure for obtaining care at any time.

c. Maintenance of Equipment

The HCP should ensure that:

- A complete inventory record of all items of medical equipment is maintained, including dates on which servicing or calibration is required.
- All items of equipment are checked and serviced or calibrated as appropriate on a regular basis to ensure efficient operation.

d. Inventory Control

The HCP should ensure that:

- Appropriate stock control levels of medications are maintained at all times.
- A system is maintained for the rotation of stock and identification of out-of-date drugs.
- Arrangements are in place for the resupply of drugs and materials in accordance with the local regulations.
- All requests for supply of drugs and materials are signed by the HCP and approved by local management.
- All requests for new or alternate medications or supplies are discussed with the Esso physician advising the operation.
- The proper indications and use of all medications at the work location are clearly understood and labeled in a language that the HCP can read.

e. Controlled Drugs

In certain countries, the supply and use of controlled drugs (e.g. narcotic analgesics) is governed by applicable laws or regulations.

The HCP should ensure that:

- All requests for resupply of controlled drugs are brought to the attention of the Esso physician advising the operation.
- Controlled drugs are hand-carried to the work location by the HCP, or an approved person, accompanied by the appropriate documentation.
- Controlled drugs are stored in a secure, locked container fixed to the floor or wall, and the keys held by the HCP and/or local manager.
- A signed and dated controlled drug register is maintained with information on



MEDICAL SERVICE GUIDELINES FOR REMOTE SITES

- name of drug, strength, and quantity.
- Stocks of controlled drugs are checked periodically with appropriate entries in the register after any usage (e.g. date, patient name, dosage, drug remaining in stock, and HCP signature).
- Expired controlled drugs are disposed of in accordance with applicable laws and regulations and with appropriate documentation and register entries.

2.3.4 Transportation

This includes ground, water and air transportation, as required to ferry the HCP, the sick/injured personnel, and the supplies from one place to another. The appropriate mode of transportation will depend upon availability, weather conditions, time of day, and various other factors such as the severity and stability of the medical condition.



MEDICAL SERVICE GUIDELINES FOR REMOTE SITES

a. Ambulance

The HCP should have ready access to an ambulance or a fully equipped modified vehicle capable of carrying at least two ill or injured persons from work sites, heliport, airport or sea base to the sick bay or to another provider facility or to airport for medevac on a 24 hour basis. The means of accessing or acquiring the vehicle should be determined in advance in consultation with company management.

The ambulance should meet the following requirements:

- Properly maintained and mechanically reliable.
- Ability to navigate the local terrain safely.
- Availability of a trained and experienced driver, familiar with the direct and alternate routes.
- Radio communication at all times.
- One properly secured stretcher with blanket.
- Adequate space for a health professional to render care in transit.
- Easy access for stretcher in/out of ambulance.
- Adequate ventilation and temperature control.
- Designated locations in the cabin to properly secure accessible life support equipment, including:
 - + Oxygen/suction with AC/DC capability
 - + Intravenous drip stand/hook
 - + Monitor defibrillator with AC/DC capability
 - + Intravenous fluids and other advanced life support medications
 - + Dressings, splints, cervical collars and spinal board

b. Helicopter/Fixed Wing Aircraft or Boat

Depending on the location (onshore or offshore) and how remote it is, air or water transportation may be preferable to a ground ambulance. In this case, a helicopter/fixed wing aircraft or boat, as applicable, should be made available/accessible on a 24 hour basis. The helicopter/aircraft or boat should have similar features as those outlined for the ground ambulance.

2.3.5 Communication

a. Telephone/Fax Machine

The sick bay should have a reliable national and international telecommunication linkage, including the capability of fax and modem transmission.

MEDICAL SERVICE GUIDELINES FOR REMOTE SITES





MEDICAL SERVICE GUIDELINES FOR REMOTE SITES

b. Radio Communication

Radio communication must be established between the various worksites, the sick bay, and the ambulance. The HCP must carry a hand held radio/beeper or equivalent at all times.

2.4 PROCEDURES

To assure adequate delivery of health care in a remote environment, the HCP must have access to professional operating protocols, procedures and reference materials. These items are essential to maintain consistency, operational standards, and practices.

2.4.1 Medical Evacuation

a. Management of Medical Problems at Remote Sites

Most minor illnesses and injuries arising at the remote site can be adequately treated by the HCP, in consultation with an external consulting physician, as required. In managing such cases, the HCP must determine:

- Whether the existing medical condition will affect the individual's fitness for duty.
- Whether any necessary treatment may affect the individual's fitness for duty.
- How long the medical condition may take to resolve.

In cases where a minor medical condition renders an individual unfit for duty but does not require medical evacuation referral, it is important that the HCP discuss with local management whether the individual should remain at the remote work location (e.g. in the sick bay) while the condition resolves. This decision may depend upon a number of factors, including:

- How confident the HCP may be that the individual will become fit for duty within a specified/defined period of time (e.g. 24 or 48 hours).

b. Indications for Medical Evacuation



MEDICAL SERVICE GUIDELINES FOR REMOTE SITES

The need to evacuate an individual to an acceptable medical facility may be determined by a number of factors, including:

- The need for critical or convalescent hospital care or other appropriate specialty care.
- The need for further examination and investigation to determine the diagnosis.
- Likely fitness for duty within a limited/specified period.



MEDICAL SERVICE GUIDELINES FOR REMOTE SITES

c. Transportation Issues

The need for safe, medically appropriate, and properly planned transport far outweighs any indication for speed. The HCP, in consultation with the external consulting physician, will recommend the timing and type of transport based on at least the following factors:

- Assessment of the seriousness and stability of patient's condition.
- Risk associated with transport (e.g. altitude, bumpy roads).
- Time of the day (e.g. limitations on night time travel).
- Weather conditions, present and predicted.

Before any decision is made to mobilize a vehicle, aircraft or boat in any adverse conditions, the HCP, external consulting physician, Esso physician advising the operation and local management should assess the risk of delay to the patient and consider the risk to others involved in the evacuation.

d. Procedures to be Followed by the HCP:

When the HCP identifies the need for medical evacuation of an ill/injured individual, the following procedures should be followed:

- Discuss the clinical situation and reception arrangements with the external consulting physician and the Esso physician advising the operation.
- Advise local management of the expected medevac and request that appropriate transportation arrangements be initiated.
- Request management authorization for onward international evacuation, if required (local management will activate EMERS to seek endorsement from the Esso physician on call).
- Prepare an appropriate referral note to the receiving physician.
- Ensure that the patient is medically stabilized for transportation.
- Advise receiving physician of likely estimated time of arrival of patient.
- Make arrangements for an escort to accompany patient.
- Fully brief and provision (e.g. medications, equipment, and supplies) the individual who will escort the patient on the medevac.
- Accompany patient to the vehicle/vessel/aircraft and ensure that the driver/captain is advised of any specific requirements regarding transportation (e.g. altitude limitations).

e. Medical Escorts

It is important that any ill/injured patient be accompanied during transport by a



MEDICAL SERVICE GUIDELINES FOR REMOTE SITES

capable escort who is aware of the medical problem and is properly trained and provisioned to deal with all predictable problems which might arise during the journey. The selection of the escort must be based upon the seriousness and stability of the condition. An escort with acceptable training and experience for a less serious problem might be a supervisor or coworker with advanced first aid training.

The HCP may need to serve as the local escort in serious or unstable cases. In such situations the HCP and local management should arrange for best available on-site backup support in the absence of the HCP. As soon as the case has been transferred, local management should arrange for the HCP to be promptly returned to the remote site.

f. Reception

Prior to departing from the operational area, the HCP and the external consulting physician will determine whether the patient should be:

- Transported directly to the best available local medical facility or to another facility with an equal or greater level of care.
- Examined immediately by the receiving physician upon arrival (e.g. at the harbor/heliport/airport) or transported to the receiving medical facility for initial evaluation.

Where ambulance transportation is required for the journey from harbor/heliport/airport to hospital, this should be organized by the receiving doctor.

Following examination/assessment, the receiving physician will render an opinion as to whether the individual:

- Requires onward evacuation for further evaluation and/or treatment.
- Should return to home country or elsewhere for convalescent care and management.
- Is fit to return to the remote work location and resume usual or restricted duties.

g. Assessment of Fitness for Duty

If the receiving physician considers that an individual has made an appropriate recovery and is fit to return for usual, alternate or limited duties, the case must be reviewed by the Esso physician advising the operation and local management to



MEDICAL SERVICE GUIDELINES FOR REMOTE SITES

ensure that there is no residual problem or medication requirement which may affect fitness for usual, alternate or limited duty.

The Esso physician advising the operation must review and document any plan for return to duty with local management and the remote site HCP.



MEDICAL SERVICE GUIDELINES FOR REMOTE SITES

2.4.2 Standard Operating Procedures/Protocols

A non-physician HCP working in a remote location, must carry out medical service duties independently without assistance or direct supervision of a physician. The HCP should therefore operate in accordance with a set of written standing orders prepared and/or endorsed by the external consulting physician.

The standing operating protocols should:

- Detail all clinical practice and procedures normally outside the scope of a supervised HCP.
- Be reviewed, understood and signed by the HCP.
- Be updated as appropriate to reflect generally accepted changes in clinical practice or procedures.

A set of standing orders should be held by the HCP and the Esso physician advising the operation. The standing orders should cover the following procedures:

a. General Protocols

- General medical protocol.
- General advanced life support.
- Apparent death due to injury.
- Paramedic-physician consultation.

b. Specific Protocols

- Cardiac Protocols
 - + Ventricular fibrillation
 - + Ventricular tachycardia
 - + Asystole
 - + Idioventricular rhythm
 - + Electromechanical dissociation
 - + Bradycardia
 - + Paroxysmal supraventricular tachycardia
 - + Premature ventricular contraction
 - + Atrial flutter/fibrillation
 - + Cardiogenic shock
 - + Angina pectoris/myocardial infarction
 - + Non-viable cardiac arrest
 - + Fluid challenge
 - + ACLS infusions



MEDICAL SERVICE GUIDELINES FOR REMOTE SITES

- Neurological/Psychiatric Protocols
 - + Seizures
 - + Stroke
 - + Psychosis/depression/emotional upset

- Metabolic Protocols
 - + Poisoning and overdose
 - + Hyperglycemia

 - + Hypoglycemia
 - + Heat stroke
 - + Hypothermia

- Respiratory Protocols
 - + Upper airway obstruction
 - + Acute allergic reactions/anaphylactic shock
 - + Acute bronchospasm
 - + Corrosive gas inhalation
 - + Asphyxia
 - + Acute pulmonary edema
 - + Pneumothorax

- Gastrointestinal/Genito-Urinary Protocols
 - + Acute abdomen
 - + Acute gastroenteritis
 - + Hepatitis
 - + Intestinal obstruction
 - + Peptic ulcer disease
 - + Inguinal hernia
 - + Kidney stones

- Eye, Ear, Nose, Throat Protocols
 - + General ophthalmology
 - + Otitis externa/media
 - + Ear syringing
 - + Sinusitis/pharyngitis
 - + Epistaxis
 - + Dental caries, appliance failure, infection

- Trauma Protocols
 - + Head trauma



MEDICAL SERVICE GUIDELINES FOR REMOTE SITES

- + Spinal trauma
- + Thoracic trauma
- + Abdominal trauma
- + Fracture stabilization
- + Major burns
- + Suturing
- + Hemorrhage
- + Amputations
- + Local anesthesia/analgesia
- + Minor burns
- + Blisters

- Tropical Disease Protocols
 - + Treatment of infectious disease
 - + Infected wounds
 - + Insect bites
 - + Snake bites
 - + Malaria

Protocols must be properly stored and readily accessible for reference at any time.

c. Reference Materials

Reference materials in the form of standard medical textbooks and periodicals/journals must be properly stored and available for reference at any time. Provision for computer-based information (e.g. CD-ROM) and Internet access should also be considered.

2.4.3 Administration

The HCP must be familiar with local administrative guidelines and work closely with local management. The responsibilities and reporting relationships of the HCP must be clearly understood by all remote site supervisory personnel.

a. Working Relationships

The following aspects of working relationships should be clarified by the HCP:



MEDICAL SERVICE GUIDELINES FOR REMOTE SITES

(1) HCP and Local Manager

The HCP should have direct contact with the local remote site manager or a designated supervisor for day-to-day work guidance and obtain professional guidance from the external consulting physician and the Esso physician advising the operation. The HCP's relationship with local remote site management is important and requires the development of mutual trust and recognition that:

- The HCP has a unique professional position at the remote site.
- Medical confidentiality regarding non-occupational health concerns should be preserved and individual privacy respected. In cases where health and safety of others may be a concern (e.g. contagious disease), local management must be kept informed/advised accordingly.

(2) HCP and The External Consulting Physician

The external consulting physician must be available to provide clinical support to the HCP at all times. Once the HCP requests support from the external consulting physician, the HCP should carry out the recommendations of the external consulting physician to the best of his/her ability. In order for this relationship and subsequent patient management to be successful:

- The external consulting physician and the HCP must have an established professional relationship (e.g. prior meeting and discussion about clinical strengths and limitations, and regular meetings thereafter).
- The HCP must call the external consulting physician during the early phases of a clinical problem.
- The HCP must carry out a detailed and well documented history and



MEDICAL SERVICE GUIDELINES FOR REMOTE SITES

examination.

- The external consulting physician must provide clear advice and ensure that the HCP has understood and documented that advice.
- The external consulting physician and the HCP should share a mutual interest in clinical outcome information and maintain communication regarding ongoing clinical problems.

(3) HCP and The Esso Physician Advising The Operation

The HCP should recognize a professional relationship with the Esso physician advising the operation and ensure that:

- All clinical concerns regarding Esso personnel are communicated in a timely manner.
- Any operational concerns or requests for assistance are communicated in a timely manner.

(4) HCP and First Aid Personnel

First aid personnel, properly trained and designated by local management, should be available in all operational areas to assist the HCP in responding to severe illness or injury, as required. The HCP should be recognized as the first aid team leader. In order for this relationship and subsequent patient management to be successful:

- The HCP must meet regularly with all first aid personnel.
- The HCP should organize and participate in ongoing training of first aid personnel.
- The HCP must clearly communicate roles and responsibilities in the event of a medical emergency.

(5) HCP and the Workforce

The HCP must be prepared to earn the respect and trust of the workforce. In order to be effective the HCP must:



MEDICAL SERVICE GUIDELINES FOR REMOTE SITES

- Communicate clearly with the workforce and raise awareness about the roles, responsibilities, and operation of the remote site medical service.
- Understand the working environment and operations.
- Maintain a professional attitude and appearance at all times.
- Display appropriate compassion and understanding for every member of the workforce, without discrimination.
- Preserve appropriate medical confidentiality for non-occupational health concerns and respect individual privacy.

b. Documentation and Medical Record Keeping

The HCP is responsible for preparing or maintaining:

(1) Confidential Medical Records

Detailed and factual medical records must be kept on all clinical interactions, discussions, and consultations in order to:

- Ensure effective management of ongoing medical conditions.
- Provide proper continuity of care.
- Enable identification of possible work-related illness.

These records should be treated appropriately, must be stored in suitable locked cabinets/containers, and be accessible only to medical personnel.

The HCP should maintain a confidential medical file for each employee at the remote site with the following information:

- Name
- Date of birth
- Job Title
- Employer
- Address
- Name and address of personal doctor, if available
- Any known allergies
- Significant past medical history
- Present treatment/medication
- Blood group, if known

The HCP should update the employee medical file after each clinical encounter with the following information:



MEDICAL SERVICE GUIDELINES FOR REMOTE SITES

- Date and time
- History of present illness

- Findings on clinical examination
- Details of any external physician consultation
- Provisional diagnosis
- Treatment and/or advice offered to the patient
- Follow-up recommendations/disposition

Medical record files on Esso employees should be transferred to the Esso physician advising the operation when the employee completes the remote site assignment.

(2) Daily Sick Bay Attendance Record

A daily log of personnel reporting to the sick bay should be maintained by the HCP so that clinical services utilization can be analyzed.

This information will be distributed to non-medical personnel; therefore, the log should not contain confidential medical information regarding specific diagnoses and treatment. It should include:

- Employee name and job title
- Employer's name
- Date and time of attendance
- Diagnostic category (e.g. major or minor illness or injury; with or without treatment)
- Disposition

(3) Medical Evacuation Notification and Records

When an individual requires medical evacuation, the following documentation will be needed:

(i) Communication to Management

Since this information will be distributed to non-medical personnel, the records should not contain confidential medical information regarding specific diagnoses and treatment. It should include:



MEDICAL SERVICE GUIDELINES FOR REMOTE SITES

- Employee name
- Whether condition is illness or injury
- Method of transportation
- Time of arrival to the place of referral
- Reception arrangements (e.g. walking, wheelchair, or stretcher)
- Name of receiving physician and medical facility
- Names of remote site supervisory personnel who have been informed

(ii) Referral Note from the HCP to the Receiving Physician

The HCP must always send a referral note to the receiving physician with the following information:

- Patient details: name, address, date of birth, name of patient's private doctor, if available
- History of present illness and relevant past medical history
- Findings on clinical examination
- Provisional diagnosis
- Details on any treatment given

The HCP must retain a copy of the note in the patient's confidential medical record file.

(4) Accident Notification

The HCP should clarify local management expectations regarding what and when information must be reported after an illness or injury occurs at the remote site.

(5) Injury/Illness Statistics

It is important to gather data which will permit measurement and analysis of illness and injury trends and statistics in order to:

- Identify areas which may require further investigation
- Identify illness which may be arising as a result of occupational exposure
- Determine whether preventive or remedial measures are effective at controlling illness and injury.

The Esso physician advising the operation should assist local management in the interpretation of this data.



MEDICAL SERVICE GUIDELINES FOR REMOTE SITES

c. Inventory of Supplies

The HCP must maintain a written inventory of medications, supplies, and equipment. This inventory should include:

- (1) Date of initial supply or resupply
- (2) Name and description of each individual item (e.g. indicate dosage form and strength of medications)
- (3) Quantity
- (4) Manufacturer
- (5) Expiration date, where appropriate
- (6) Service date (including battery recharging and testing, where appropriate)
- (7) Balance in stock by date

For controlled drugs, a separate page should be maintained for each drug, and it should be administered in accordance with applicable laws and regulations (see 2.3.3 e).

d. Checklists

Written checklists for various activities/inspections (e.g. industrial hygiene, food hygiene and environmental health) should be established or adopted and used regularly to ensure consistency and to document completion of the task. Examples of the relevant checklists are shown in Appendix III.

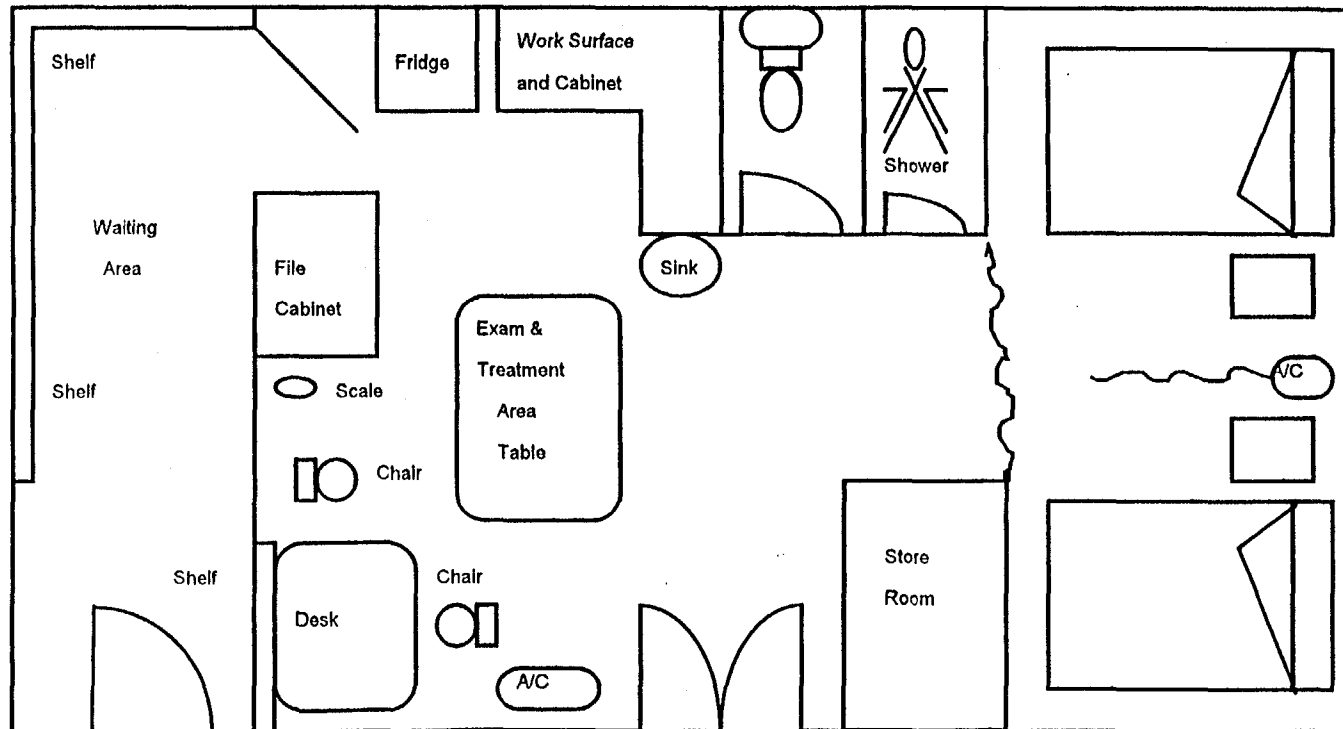


MEDICAL SERVICE GUIDELINES FOR REMOTE SITES

APPENDIX I. RECOMMENDED SICK BAY LAYOUT



MEDICAL SERVICE GUIDELINES FOR REMOTE SITES





MEDICAL SERVICE GUIDELINES FOR REMOTE SITES

APPENDIX II

RECOMMENDED LIST OF DRUGS AND EQUIPMENT

The following are lists of drugs and equipment recommended for remote sites. They should be used as a guideline to help define site-specific inventories, since a single set of minimal requirements would not likely meet the needs of any individual operation. The selection and numbers of individual inventory items should be made by the HCP and the external consulting physician; however, the final inventory must be approved by the Esso physician advising the operation. The most critical drugs and equipment should be on-site and operational when the delivery of services is set to begin. Certain critical medical supplies and equipment should be pre-packaged and made available for emergency use at dispersed sites or during patient transport.

The Drug List (A) corresponds to select categories of drugs found in the Physician's Desk Reference (PDR) which are likely to be useful in the management of emergencies and acute routine medical problems. Examples are given of specific drugs in each category that might be considered for the remote site pharmacy. The selection of a particular drug within a given category should be based in large part upon the preferences and experience of the HCP. Drugs which are used for the treatment of chronic medical problems are not required at the remote site. Any individual visiting or residing at the remote site with a chronic medical problem requiring regular treatment, should be advised to carry sufficient quantities of necessary medications to last the duration of their stay.

The lists of Equipment (B) and Soft Goods (C) detail the specific items recommended for the remote site which are likely to be useful in the management of emergencies and acute routine medical problems. They should be acquired, maintained, stored, administered and disposed of in accordance with applicable laws and regulations. The addition, deletion, or substitution of items should be based in large part upon the preferences and experience of the HCP and the external consulting physician.

A. DRUG LIST

1. Analgesics

Acetaminophen
Aspirin

NSAIDS, e.g.: Ibuprofen



MEDICAL SERVICE GUIDELINES FOR REMOTE SITES

Mefenamic acid
Naproxen



MEDICAL SERVICE GUIDELINES FOR REMOTE SITES

Narcotic e.g.: Meperidine
Nalbuphine
Pentazocine

2. Anesthetics

Local, e.g.: Bupivacaine
Mepivacaine

Topical, e.g.: Benzocaine
Emla cream
Ethylchloride spray

3. Anorectal Products

Creams, e.g.: Analpram-HC
Anusol-HC

Suppositories, e.g.: Anusol-HC

4. Antacids and Antiflatulents

Antacid/Antiflatulent combinations, e.g.: Mylanta
Simethicone

5. Antibiotics, Systemic

Cephalosporins, e.g.: Cefadroxil
Cefaclor
Cefotaxime
Ceftriaxone

Macrolides, e.g.: Erythromycins

Penicillins, e.g.: Amoxicillin
Ampicillin
Augmentin (Amoxicillin/Clavulanate)
Penicillin
Unasyn (Ampicillin/Sulbactam)



MEDICAL SERVICE GUIDELINES FOR REMOTE SITES

Quinolones, e.g.: Ciproflaxacin
Ofloxacin



MEDICAL SERVICE GUIDELINES FOR REMOTE SITES

Sulfonamides, e.g.: Cotrimoxazole

Tetracyclines e.g.: Doxycycline
Minocycline
Oxytetracycline

6. Anticoagulants

e.g.: Heparin Lock Flush Solution
Heparin Sodium Injection

7. Antihistamines

e.g.: Astemizole (Hismanal)
Chlorpheniramine maleate
Diphenhydramine (Benadryl)
Hydroxyzine (Atarax)
Loratadine (Claritin)

8. Anti-inflammatory Agents

Non-Steroidals e.g.: Ibuprofen
Mefenamic acid

(Steroidals: see (23): Hormones-glucocorticoid)

9. Antiparasitics

Lice e.g.: Kwell Cream & Lotion
Lindane shampoo

Scabies e.g.: Crotamiton (Eurax)
Lindane Lotion

Helminths e.g.: Mebendazole
Thiabendazole

Protozoa e.g.: Anti-malarial: Chloroquine
Mefloquine



MEDICAL SERVICE GUIDELINES FOR REMOTE SITES

Pyrimethamine
Sulfadoxine/pyrimethamine (Fansidar)

Other - Metronidazole (Flagyl)

10. Antiseptics

e.g.: Chlorhexidine
Povidone-iodine

11. Antispasmodics & Anticholinergics

e.g.: Dicyclomine
Librax (Roche)
Propantheline

12. Antivirals, Systemic

e.g.: Acyclovir

13. Biologicals

Antiserum e.g.: Antivenin
Antivenin (Crotalidae) Polyvalent

Toxoids e.g.: Diphtheria & Tetanus Toxoids
Diphtheria & Tetanus Toxoids & Pertussis vaccine
Tetanus Toxoid Adsorbed

Vaccines e.g.: Cholera Vaccine
Engerix-B
Rabies Vaccine
Typhoid Vaccine

14. Cardiovascular Agents

Adrenergic Blockers e.g.: Phenoxy-benzamine
Prazosin

Adrenergic Stimulants e.g.: Adrenaline



MEDICAL SERVICE GUIDELINES FOR REMOTE SITES

Clonidine

Angiotensin Converting Enzyme Inhibitors e.g.: Captopril
Enalapril

Antiarrhythmics e.g.: Adenosine
Lidocaine
Procainamide
Verapamil

Beta Blockers e.g.: Atenolol
Propranolol

Calcium Channel Blockers e.g.: Nifedipine

Diuretics e.g.: Furosemide
Thiazides

Vasodilators, e.g.: NitroGlycerin
Nitroprusside

15. Cold & Cough Preparations

Antihistamines e.g.: Terfenadine
Phenergan with Dextromethorphan

Antitussives e.g.: Bromfed Cough Syrup (Muro.)

Decongestants e.g.: Pseudoephedrine

Expectorants e.g.: Guaifenesin

16. Dental Preparations e.g.: Hurracaine Topical Anesthetic

17. Dermatologicals

Antibacterials e.g.: Nitrofurazone cream
Sulfamylon cream

Antibiotics e.g.: Clindamycin



MEDICAL SERVICE GUIDELINES FOR REMOTE SITES

Gentamycin

Anti-Inflammatory Agents e.g.: Hydrocortisone

Burn Relief e.g.: Silvadene Cream

Cleansing Agents e.g.: Povidone-iodine
pHisoHex

Dandruff Medications e.g.: Selenium Sulfide Lotion

Fungicides e.g.: Clotrimazole
Nystatin

Herpes Treatment e.g.: Acyclovir

Moisturizer

Pruritus Medications e.g.: Betamethasone
Triamcinolone

18. Diarrhea Medications

e.g.: Loperamide
Pepto-Bismol

19. Electrolytes

Fluid Replacement Therapy e.g.: Oral Rehydration Solution

20. Fungal Medications

e.g.: Griseofulvin
Nystatin

21. Acute Gout Treatment

e.g.: Colchicine

22. Histamine H2 Receptor Antagonists



MEDICAL SERVICE GUIDELINES FOR REMOTE SITES

e.g.: Cimetidine
Ranitidine

23. Hormones

Glucocorticoid e.g.: Medrol Dosepak
Oral-Prednisolone

Injection e.g.: Dexamethasone
Methylprednisolone

Hyperglycemic Agents e.g.: Glucagon



MEDICAL SERVICE GUIDELINES FOR REMOTE SITES

24. Hypnotics & Sedatives

Hypnotics e.g.: Flurazepam
Triazolam

Sedatives e.g.: Phenobarbitone
Lorazepam

25. Laxatives

Bulk e.g.: Metamucil
Mylanta Natural Fiber

Fecal Softeners e.g.: Senokot
Stimulant e.g.: Bisacodyl

26. Migraine Preparations

Ergot Derivatives e.g.: Cafergot

27. Muscle Relaxants

Skeletal Muscle Relaxants e.g.: Baclofen

Smooth Muscle Relaxants e.g.: Flavoxate (Urispas)

28. Nasal Sprays

e.g.: Cromolyn Nasal Spray
Beclomethasone (Beconase)

29. Nausea Medications

e.g.: Promethazine (Phenergan)
Chlorpromazine (Thorazine)

30. Ophthalmic Preparations

Anti-Infectives e.g.: Cortisporin



MEDICAL SERVICE GUIDELINES FOR REMOTE SITES

Neosporin



MEDICAL SERVICE GUIDELINES FOR REMOTE SITES

Artificial Tears e.g.: Tears Naturale Free

Beta Adrenergic Blocking Agents e.g.: Timolol

Carbonic Anhydrase Inhibitors e.g.: Acetazolamide (Diamox)

31. Otic Preparations

e.g.: Auralgan Otic Solution (Wyeth-Ayerst)
Cerumenex Drops (Purdue Frederick)
Cortisporin Otic Suspension (Burroughs Wellcome)

32. Psychotropics

Antianxiety Agents e.g.: Alprazolam
Chlordiazepoxide
Diazepam
Lorazepam

33. Respiratory Drugs

Anti-Inflammatory Agents, Non-Steroidal e.g.: Intal Capsules
Intal Inhaler

Bronchial Dilators e.g.: Ipratopium (Atrovent)
Metaproterenol (Alupent)

34. Seizure Disorders

Barbiturates e.g.: Phenobarbitone

Benzodiazepines e.g.: Clorazepate
Diazepam

Hydantoin Derivatives e.g.: Dilantin

35. Vitamins

e.g.: Multivitamins



MEDICAL SERVICE GUIDELINES FOR REMOTE SITES

Multivitamins with Minerals



MEDICAL SERVICE GUIDELINES FOR REMOTE SITES

B. SUGGESTED EQUIPMENT LIST

Alligator forceps
Aluminum Backboard
Basket stretcher
Bed Pan
Dental first aid kit
Ear Syringe
Ellis forceps
Emergency cricothyroidotomy kit (disposable)
Examination couch
Examination lamp
Eye Loop with Magnet
Folding stretcher
Four point lifting bridle
Glucometer
Iodine cup
IV Module 1000ml
IV Module 500ml
Kelly forceps
Kendrick Extrication Device (KED)
Kendrick Traction Device (KTD)
Kidney basin
Kocher forceps
Laryngoscope with assorted sizes curved and straight blades
MaGill Forceps
Magnifying glass with inbuilt light
Malaria diagnostic set (as required) e.g. QBC or Para-sight F
Medication Module
Mini Portable Suction pump
Monitor / Pacer / Defibrillator EKG with AC/DC capability
Mosquito artery forceps
MTP - Infusion Pump
Nebulizer
Needle holder
Oto / Ophthalmoscope (Diagnostic set)
Oxygen Supply with regulator
Para-Sight F (Malaria) - as required
Penlight



MEDICAL SERVICE GUIDELINES FOR REMOTE SITES

Penlight (blue light) with fluorescein
Pharmacy Lock Box
Pneumatic Anti-Shock Trousers (MAST)



MEDICAL SERVICE GUIDELINES FOR REMOTE SITES

Portable Resuscitator LSP175 system
Pressure Infuser 1000ml
Pulse oximeter
Reflex Hammer
Ring Cutter
Scoop Stretcher
Sphygmomanometer with various cuff sizes
Spinal board with straps
Sterilizer (autoclave)
Stethoscope
Stomach pump and tube
Surgical Scissors
Thermometer - Ivac
Urinal
Visual Acuity Chart
Weighing Scale

C. SOFT GOODS LIST

1. Dressings

8" x 10" ABD Pads 1/pk
3" x 8" Adaptic 1/pk
1" x 3" Bandaid
Cotton wool bag
Coverlet "H" Bandaid
Eye Pads (Sterile)
4" x 4" Sponges (Sterile) 2/pk
4" x 4" Sponges (Non-sterile)
Steri-strip skin closures
3" x 8" Telfa Dressings

2. Bandages

2" Coban
3" Coban
4" Coban
2" Elastic Bandage
4" Elastic Bandage
6" Elastic Bandage



MEDICAL SERVICE GUIDELINES FOR REMOTE SITES

Multitrauma dressing
Non Sterile gauze pads
Sterile gauze pads
Sterile burn sheets
2" Stretch Gauze
4" Stretch Gauze
1" Transpore Tape
2" Transpore Tape
Triangular Bandages
Tube Gauze Size 1
2" Zonas Tape

3. Orthopedic

1/2" Alumafoam Splint
Donway Traction Splint
Extrication Collar - Small
Extrication Collar - Medium
Extrication Collar - Large
Pneumosplints (half and full arm, half and full leg)
Sam Splint (flexible splint)
Umbrella Splint
Vacuum mattress

4. Suture

Disposable Suture Tray
Disposable Suture Removal Tray
Disposable Scalpel #11
Disposable Scalpel #15
Disposable Razor
3-0 Ethilon FS-2
4-0 Ethilon FS-2
6-0 Ethilon P-3
5-0 Prolene FS-2
Steri-Strips 1/8"
Surgeon Gloves (Sterile)
4-0 Vycril PC-1
5-0 Vycril PC-1



MEDICAL SERVICE GUIDELINES FOR REMOTE SITES

5. Respiratory

Disposable BVM Resuscitator

6.0 Endotracheal Tube

7.5 Endotracheal Tube

8.5 Endotracheal Tube



MEDICAL SERVICE GUIDELINES FOR REMOTE SITES

#18 French Suction Catheter
Nasal Cannula
Nebulizer Face Mask
Non-Rebreather Face Mask
#3 Oropharyngeal Airway
#4 Oropharyngeal Airway
#5 Oropharyngeal Airway
#6 Oropharyngeal Airway
Oxygen Supply Tubing
Stylets
Suction Tubing
V-Vac Suction
Yankauer Suction Tip

6. Intravenous

14ga x 1 1/4" Angiocath
16ga x 1 1/4" Angiocath
18ga x 1 1/4" Angiocath
20ga x 1 1/4" Angiocath
Butterfly Catheter 21ga
Drip stand
Double Lumen Angiocath
Hep Locks
IV Solutions, e.g. normal saline, dextrose saline, dextrose solution, Hartmann's solution
IV Tubing Set 15gtts/ml
IV Tubing Set 60gtts/ml
Tourniquets

7. Miscellaneous

Alcohol Preps
Cidex
Cobalt Blue Light
Cold Packs
Cotton Tip Applicators (Sterile) 2/pk
Defibrillator / Pacing Pads 2/pk
Ear Speculum



MEDICAL SERVICE GUIDELINES FOR REMOTE SITES

EKG Electrodes 3/pk
EKG Paper
Emesis Basin
Epistat
Exam Gloves (Disposable)
File for vial
Foley Catheter Tray 16F
Foley Catheter Tray 18F
Glucose/dextrose for injection
Glucostix for glucometer
Hypodermic needle
Insect repellent
Ivac Temperature Probes (Disposable)
K-Y Jelly 6gm/tb
Mini 911 ST Probe Covers (Disposable)
Morgan Therapeutic Lens
Multistix urine analysis
18ga x 1 1/2" Needle
22ga x 1 1/2" Needle
27ga x 1/2" Needle
1/4" Penrose Drain
Pharmadine Solution
Salem Sump, 18F
Scrub Brushes / Sponge Plain
Sharp-Trap Container
Sharps Container
Suction Canister
Surgical Mask
3cc Syringe
5cc Syringe
10cc Syringe
60cc Syringe w/Luer Tip
60cc Syringe w/Cath Tip
TB Syringe w/25ga Needles
Tongue Blades 1/pk
Tube Gauze Applicator Size 1
Tuning fork
Water for injection
(Standard alcohol and drug test collection kits will be provided by the Company)



MEDICAL SERVICE GUIDELINES FOR REMOTE SITES

8. Dental

Backhaus Towel Clamp
Cavit
Cement Spatulas
#2 Cotton Rolls
Dental Pliers
Duelon C D
Extracting Forceps
Iris Scissors
Mouth Props Adult
#5 Plastic Mouth Mirror
Sani-Cloth Large
Topex Gel - bubblegum
Veratex Explorer
VTX McCall Scaler

9. Medical References

1. *Merck Manual*
Published by Merck, Sharp & Dohme, Merck and Co. Inc.
Rahway, NJ
2. *First Responder*
Published by Robert J. Brady Co.,
Bowie, Maryland 20715, U.S.A.
3. *Emergency in the Streets*
Published by Little, Brown and Company
Boston Massachusetts 02106, U.S.A.
4. *Atlas of Emergency Medicine*
Published by Williams & Wilkins
428 East Preston Street
Baltimore, MD 21202, U.S.A.
5. *Manson's Tropical Diseases*
Manson-Bahr, Bell
6. *Essential Malariology*



MEDICAL SERVICE GUIDELINES FOR REMOTE SITES

Bruce-Chwatt

7. *Short Text Book of Preventive Medicine for the Tropics*
Lucas and Gilles
8. *A Colour Atlas of Tropical Medicine and Parasitology*
Peters and Gilles

Books from 5 to 8 are published by
Bailliere Tindall, 24 - 28 Oval Road,
London NW1 7DX, England

9. *Current Emergency Medical Diagnosis and Treatment*
10. *Current Medical Diagnosis and Treatment*
11. *Current Surgical Diagnosis and Treatment*

Books 9 to 11 are published by
Appelton & Lange, 25 Van Zant Street,
East Norwalk, Connecticut 06855

12. *Clinical Guidelines,
Diagnostic and Treatment Manual*
13. *Minor Surgical Procedures in Remote Areas*
14. *Ophthalmology in Remote Areas*

Books 12 to 14 are published by
Medecins sans Frontieres
8 rue Saint-Sabin
75011 Paris

15. *Physicians' Desk Reference (Current Edition)*

P.O. Box 10689
Des Moines, Iowa 50336-0689
U.S.A.



MEDICAL SERVICE GUIDELINES FOR REMOTE SITES

16. *British National Formulary* (Current Edition)

British Medical Association
Tavistock Square
London WC1H 9JP, England



MEDICAL SERVICE GUIDELINES FOR REMOTE SITES

APPENDIX III.

EXAMPLES OF OCCUPATIONAL HEALTH CHECKLISTS

A. FOOD SANITATION CHECKLIST

QUALITY

- 1. Original container or otherwise safe source, no spoilage.
- 2. Safe source of meat and poultry supplies.
- 3. Delivery containers properly cleaned between use.

PROTECTION

- 1. Potentially hazardous foods kept at correct temperatures during transport, storage, preparation and service.
 - Refrigeration kept at 7°C (45°F) or below.
 - Hot storage at 60°C (140°F) or above.
 - Frozen foods kept at -18°C (0°F).
 - Poultry and stuffed meats cooked at 74°C (165°F) or above - all parts.
 - Other foods requiring cooking to be rapidly cooked to heat all parts to at least 60°C (140°F).
 - Food kept properly warmed/cooled if delayed in serving by more than 30 minutes.
 - Potentially hazardous foods properly thawed in refrigerator or under water of 21°C (70°F) or less.
- 2. Accurate thermometers in use/visible.
- 3. Field foods properly selected and prepared.
 - Avoid using meats that may spoil.
 - Cheeses/non-spoiling protein sources used.
 - Milk/creamed dishes not sent.
 - Transport in sanitized containers.



MEDICAL SERVICE GUIDELINES FOR REMOTE SITES

___ Sanitize containers prior to each use.

PERSONNEL

- ___ 1. Hands washed and cleaned, good hygienic practices, clean clothes.
- ___ 2. Personnel with infections restricted from food contact areas/jobs.
- ___ 3. Food preparation personnel careful when crossover from raw to cooked foods, maintain good hygienic practices.
- ___ 4. Food not picked up by fingers during preparation/serving unless absolutely necessary and plastic gloves used.
- ___ 5. First aid facilities/materials available.

FOOD EQUIPMENT/UTENSILS

- ___ 1. Properly designed, able to be properly cleaned/sanitized.
- ___ 2. Thoroughly cleaned after use and between use when handling raw foods to use for cooked foods (crossover use).
 - ___ Pre-flushed, scraped, soaked
 - ___ Washed, rinsed, sanitized at proper temperatures
- ___ 3. Sanitizing of all food contact surfaces after cleaning by:
 - ___ Either immersion for at least 30 seconds in water heated to 77°C (170°F) or
 - ___ In dish washing machine with a 10-15 second spray of water heated to 82°C (180°F) or
 - ___ By immersion in a chemically treated final rinse (several chemical sanitizers available).
- ___ 4. Single-use utensils properly stored, not reused.
- ___ 5. Accurate thermometers in use/visible.
- ___ 6. Food cutting (butchery surfaces in good condition/cleaned).

OTHER

- ___ 1. Water sources safe.
- ___ 2. Hot and cold water available.
- ___ 3. Sewage and waste water properly disposed.
- ___ 4. Garbage/refuse containers/receptacles:
 - ___ Kept covered between use.
 - ___ Insect/rodent proof.
 - ___ Cleaned frequently.



MEDICAL SERVICE GUIDELINES FOR REMOTE SITES

- 5. Toxic items properly stored, labeled, used.
- 6. Premises maintained free of litter and other unnecessary articles.
- 7. Complete separation from living/sleeping quarters.

B. WATER SAMPLE COLLECTION CHECKLIST

- 1. Use the proper sample container (e.g., bottle treated with sodium thiosulfate is needed if testing system has any chlorine residual for bacteria count).
- 2. Turn water on (if tap water) and let run for several minutes.
- 3. Open the sample container carefully to void hand/finger contact with lip of container or inside of lid.
- 4. Fill container all the way full with no air space on top.
- 5. Screw/clamp lid back on container and label container with date, time, location of water source and who collected sample.
- 6. Include any additional information regarding water sample as needed (e.g., suspicions of and type of contamination if any).
- 7. Promptly carry/send sample to lab (for bacterial analysis; this may mean returning the sample to the lab within 24 or 48 hours).

C. DRINKING WATER CHECKLIST

WATER QUALITY

- 1. Water source properly located.
 - Minimum of 50 feet from sewer or septic tank.
 - Minimum of 100 feet from pit privy.
 - Minimum of 150 feet from all other fecal waste sources.
- 2. Water supply systems properly constructed.
 - Trenches dug as needed to divert surface runoff from around well head.
 - Water source screened/otherwise protected to avoid access by birds, animals or insects.
- 3. Water additionally treated as needed to assure safe use.
 - Filtration conducted if cloudy, and
 - Water disinfected with chlorine (or equivalent).
- 4. Alternate/emergency water supply maintained if necessary to assure water availability in dry/unpredictable weather situations.
- 5. Potable water tanks chlorinated to at least 5 ppm at the time of storage.
- 6. Potable water system, including all distribution lines, adequately treated (greater than or equal to 0.5 ppm chlorine residual) by a chlorination system.



MEDICAL SERVICE GUIDELINES FOR REMOTE SITES

- ___ 7. Acceptable evidence of potability.
- ___ 8. Potable water distribution system, chlorine system properly maintained, operated and calibrated.
- ___ 9. Potable water supply not subjected to contamination through cross connections to non-potable water supply through back-flow or back-siphonage.
- ___ 10. Only potable water supplied to the kitchen (also recommended for shower/eye wash stations) and other service areas.



MEDICAL SERVICE GUIDELINES FOR REMOTE SITES

D. WASTE WATER SANITATION CHECKLIST

LOCATION

- 1. Will not contaminate water supplies or seafood sources.
- 2. Prevent contact with humans, pets, foodstuffs.
- 3. Prevent access by flies, mosquitoes, other insects, rodents or other animals.
- 4. Prevent pollution of bathing and recreational areas.
- 5. Excreta/non-excreta containing streams are separated.

PRIVIES

- 1. Soil has good drainage properties.
- 2 feet of suitable soil between trenches/leaching pits and highest ground water or impermeable layer.
- 2. Ground water not contaminated.
- 3. At least 30 meters (100 feet) from surface water and kitchen.
- 4. At least 15 meters (50 feet) from sleeping quarters.
- 5. Provide toilet paper.
- 6. Add lime periodically to control odors.
- 7. System is insect/rodent proof.

LEACHING/SEEPAGE PIT

- 1. Water sources uphill and 45-150 meters (150-500 feet) away.
- 2. Bottom of pit 4 feet above highest ground water level.
- 3. Wall construction of
 - Field stones
 - Cinder
 - Stone concrete blocks
 - Special cesspool blocks
- 4. Bottom of pit filled with gravel.

E. VECTOR CONTROL CHECKLIST

PREVENTION OF VECTOR ACCESS

- 1. Food sources removed from vector access.



MEDICAL SERVICE GUIDELINES FOR REMOTE SITES

- Fruit and vegetables stored in refrigerator or vector-proof containers.
- Foods stored in tightly covered containers.
- 2. Refuse stored in closed containers and cleaned frequently.
- 3. Access to privies, toilets, etc. eliminated through the use of screen doors, air curtains, etc.
- 4. Access to laundry soaps and candles prevented.
- 5. Standing water eliminated.

PESTICIDE APPLICATION

- 1. Water and food supplies protected and not contaminated.
- 2. Appropriate pesticides used.
- 3. Pesticide applicators protected with appropriate respirators, clothing and goggles.
- 4. Toxic items properly stored, labeled and used.

PERSONAL PROTECTION

- 1. Appropriate spray-on or wipe-on repellent worn.
- 2. Long sleeved shirts and pants worn where appropriate (e.g., ticks, mosquitoes).
- 3. Periodic inspection of clothing and body (ticks).

REDUCING SOURCES FOR MOSQUITOES

- 1. For smaller bodies of water, source reduced by one or more of the following:
 - Use tide gates
 - Drain wet areas, streams or ditches
 - Grade the surface
 - Clear brush
 - Remove containers that can collect water
- 2. For larger bodies of water, source reduced by one or more of the following:
 - Stock the water with fish
 - Change the salinity
 - Change the water level
 - Agitate the water surface



MEDICAL SERVICE GUIDELINES FOR REMOTE SITES

APPENDIX IV.

ALCOHOL & DRUG SPECIMEN COLLECTION PROCEDURES

(FOR MEDICAL PERSONNEL OUTSIDE USA)

The following "checklist" is provided as a guide in the collection process.

I. Identification/Informed Consent/Chain of Custody

- Ask individual providing specimen for company identification to assure identity.
- Have the next blank Chain of Custody form, with ID labels, available for use (Attachment 1).
- Complete the Esso Informed Consent Form; 1-page version, (Attachment 2).

Donor should be reminded to list all prescription and non-prescription medications used in the past 30 days. Accuracy and completeness of this list is very important!

- Affix one of the small "I.D. labels" from the attached Chain of Custody Form onto this Informed Consent Form.
- Open the plastic covered/sealed kit to be used for this collection in the presence of the individual to be tested.

II. Urine Collection for Drug Screening

- Have individual remove all outer garments (overcoats and jackets), leave purses, briefcases, etc. in a secure location and wash hands prior to collection.
- The collector should remain immediately outside lavatory while the individual voids in privacy.

Consider use of added measures to ensure unaltered specimen (e.g., toilet water bluing agent, taping of water spigots or closed-off valves).



MEDICAL SERVICE GUIDELINES FOR REMOTE SITES

- Collect urine specimen by asking the individual to fill the specimen bottle at least three quarters full with urine. There must be at least 60 ml of urine for the specimen to be tested by the laboratory. The individual should be asked to finish voiding completely after the specimen collection is completed.



MEDICAL SERVICE GUIDELINES FOR REMOTE SITES

(Individuals who cannot provide the 60 ml of urine should remain in the collection site and drink eight ounces of fluid every 20 minutes until adequate urination occurs.)

- In the presence of the individual, the collector checks the temperature of the urine (e.g., viewing the temperature strip on the side of the specimen bottle).
 - The urine collected must be in the temperature range of 94 to 99 degrees Fahrenheit if read within a two-minute time span after urination.
 - If read within a four-minute time span, temperature range must be between 90.5 and 94 degrees Fahrenheit.
- If the individual provides a "cold" specimen, attempt a second non-observed sample. If a second sample is not within the prescribed temperature range, the individual's body temperature should be checked. The urine specimen must be within a 6 degree range lower than the individual's body temperature. If not, an observed collection may be necessary.
- SEAL THE SPECIMEN, in full view of the individual, using the tamper-proof seal normally provided on the Chain of Custody Form. The seal must be placed over the lid or cap of the bottle, with the ends of the seal coming down the sides of the bottle.
- Have the donor initial and date this specimen seal.
- COMPLETE THE CHAIN OF CUSTODY FORM as follows:
 - Have the donor print his/her name in the space labeled "PATIENT" or "DONOR NAME" and enter either the last four digits of their personal ID or Social Security Number or entire number in the space provided on the form.
- Do NOT complete the list of medications section on the Chain of Custody Form. They SHOULD be listed on the Informed Consent Form which was completed in "I" above.
- THE DONOR MUST SIGN AND DATE THE PATIENT AFFIDAVIT SECTION OF THE CHAIN OF CUSTODY FORM.



MEDICAL SERVICE GUIDELINES FOR REMOTE SITES

- Place the sealed urine bottle in the small plastic specimen bag and enclose the absorbent packet in the bag with the specimen bottle. Also, remove adhesive strips from the top of bag and seal the bag.



MEDICAL SERVICE GUIDELINES FOR REMOTE SITES

- Place specimen in the shipping box in which the specimen collection bottles were provided.
- The COLLECTOR MUST COMPLETE AND SIGN AND DATE THE COLLECTION AGENT OR COLLECTOR AFFIDAVIT SECTION OF THE CHAIN OF CUSTODY FORM. (Omission of this signature and/or date will cause the laboratory to reject the specimen!)
- Remove the pink laboratory copy of the completed Chain of Custody Form and place in the box with the specimen to go to the laboratory. A copy of the Chain of Custody Form may be kept by the Collector; the "original" (white) one is sent to the Esso Medical Review Officer.
- Do not seal the shipping box yet.

III. Screening Test for Alcohol

- Saliva Stick Method

Ensure that individual to be tested has not ingested/used alcohol-containing liquid mouthwash or mouth spray, etc. just before test. If yes, wait 15 minutes before proceeding.

- Remove the alcohol screening device from the test kit box and follow the instructions on the device's packet.
- Assure that the device's quality assurance (QA) spot is not dark brown or blue before testing. If it is, discard and use the extra device provided. Upon testing, the QA spot must turn dark brown or blue. If it does not, then the test is not valid and should be repeated with another test device.
- Reading the result: If the dark brown or blue color reaches or exceeds 0.04% or 40 mg/dl on the scale, then the screening test is POSITIVE, according to the Esso Alcohol and Drug Policy.
- Record the result of the saliva alcohol test on the Informed Consent Form.
- + If this test is NEGATIVE (below 0.04%), a confirmatory test is not required. Skip to V in these instructions.



MEDICAL SERVICE GUIDELINES FOR REMOTE SITES

- + IF THIS SCREENING TEST IS POSITIVE (at/over 0.04%), the collection of a blood specimen for shipment to a lab for confirmatory testing is necessary. Proceed to IV for next steps.

IV. Confirmatory Alcohol Testing

- Blood Specimen
 - The blood specimen is to be taken in the tube provided, and should be obtained immediately after the saliva test indicates a positive. (Note: Please use the cleansing swab in the kit and not one that contains alcohol.)
 - On the blood tube, please print the following information on the white label:
 - +Collector's initials.
 - + Date and time of collection.
 - + Social Security Number or another employee identification number already used on the Chain of Custody Form.
 - SEAL THE SPECIMEN, and do it in full view of the donor by applying one of the small I.D. labels from the Chain of Custody Form across the stopper and down both sides of the tube.
 - Place the blood tube into the shipment box together with laboratory copy of the Chain of Custody Form and the urine specimen.

V. Sealing the Shipping Container

- Be sure the "Laboratory" copy of the Chain of Custody Form has been enclosed with the specimen(s) in the pouch prior to sealing it, together with all related specimens.
- Affix the Nichols Lab address label to the outside of the box:

Coming Nichols Institute
Substance Abuse Testing
7470 Mission Valley Road
San Diego, CA 92108-4406
U.S.A.



MEDICAL SERVICE GUIDELINES FOR REMOTE SITES

- Seal the container using the "Box Custody Seal."

VI. Specimen Pickup and Shipping

- Notify a courier services in advance of a planned need for a pickup on the day of testing in order to assure a speedy pickup and delivery of the specimen.



MEDICAL SERVICE GUIDELINES FOR REMOTE SITES

- Package the specimens in any pre-provided courier envelopes or boxes.
- It is suggested that a notation be made by the physician, in his/her copy of the patient's medical record, of the following:
 - Courier's waybill number.
 - If available, a specimen I.D.# label from the Chain of Custody Form. If not available, accurately copy the I.D.# in your record.

VII. Distribution of Forms

- To: Medical Review Officer (via fastest method, e.g. courier service)

Esso Company, International
Medicine and Environmental Health Dept.
200 Park Avenue
Florham Park, New Jersey 07932
Telephone: (201) 765-4647
Fax: (201) 765-4429

- Original Chain of Custody Form (top sheet). If necessary, the local collecting doctor can make a copy for retention.
- Esso Alcohol/Drug Informed Consent Form.
- To: Collecting Physician's Files
 - Courier's waybill documents.
 - Optional: Copy of Chain of Custody Form.
- To: Laboratory
 - Nichols "Laboratory" copy of Chain of Custody Form (does not contain name of donor) sealed within the mailing box, with specimen(s).

INFORMED CONSENT FORM/ALCOHOL SCREEN REPORT

SPECIMEN ID NO. (OBTAIN FROM CHAIN OF CUSTODY FORM)

PURPOSE OF TEST

(CHECK ALL THAT APPLY IN BOTH COLUMNS I & II)

I	II
<input type="checkbox"/> RANDOM (DESIGNATED POSITION)	<input type="checkbox"/> ESSO EMPLOYEE
<input type="checkbox"/> RANDOM (SPECIFIED EXECUTIVE)	<input type="checkbox"/> CONTRACTOR
<input type="checkbox"/> RANDOM _____	_____
<input type="checkbox"/> FOR CAUSE	_____
<input type="checkbox"/> PRE-ENTRY (DESIGNATED POSITION)	- COMPANY NAME
<input type="checkbox"/> PERIODIC	_____
<input type="checkbox"/> PRE-EMPLOYMENT/PRE-PLACEMENT	- DATE
<input type="checkbox"/> POST-REHABILITATION	_____

I, _____ (PLEASE PRINT YOUR NAME), CONSENT TO THIS REQUEST FOR BIOLOGIC SPECIMENS. I UNDERSTAND THAT THE CHEMICAL ANALYSIS OF THESE SPECIMENS WILL BE CONDUCTED BY A QUALIFIED LABORATORY AND THAT THE ANALYTIC RESULTS WILL BE EVALUATED BY AN ESSO PHYSICIAN.

THE PURPOSE OF THIS ANALYSIS IS TO DETERMINE OR RULE OUT ALCOHOL OR DRUG ABUSE. I UNDERSTAND AND CONSENT TO THE MEDICAL DEPARTMENT REPORT TO APPROPRIATE MANAGEMENT THE RESULTS OF THE TESTS IN COMPLIANCE WITH THE ESSO ALCOHOL AND DRUG POLICY.

I UNDERSTAND THE IMPORTANCE OF ACCURATELY PROVIDING THE FOLLOWING LIST SO THAT TEST RESULTS MAY BE APPROPRIATELY INTERPRETED.

I HAVE LISTED BELOW ALL MEDICATIONS, DRUG, OR VITAMINS TAKEN IN THE LAST 30 DAYS, I HAVE INCLUDED PRESCRIPTION AND NON-PRESCRIPTION MEDICATION HEADACHE REMEDIES, "COLD" PILLS, DIET PILLS, THROAT SPRAYS, ETC. (WHEREVER POSSIBLE, PRINT THE PRESCRIPTION DRUG NAME DIRECTLY FROM ITS LABEL.

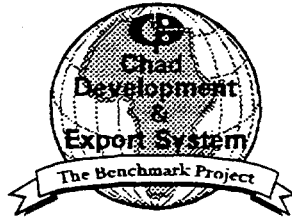
EMPLOYEE SIGNATURE	COLLECTOR/MEDICAL REPRESENTATIVE SIGNATURE/TITLE
EMPLOYEE IDENTIFICATION NUMBER	LOCATION (CITY/COUNTRY)
COMPANY NAME	TELEPHONE NUMBER
COMPANY ADDRESS	

FOR SPECIMEN COLLECTOR'S USE ONLY	
RESULT OF SCREENING TEST FOR ALCOHOL	
<input type="checkbox"/> NEGATIVE	COLLECTOR'S INITIALS
<input type="checkbox"/> POSITIVE (BLOOD SPECIMEN DRAWN FOR CONFIRMATION)	
<input type="checkbox"/> POSITIVE (SECOND URINE SPECIMEN FOR CONFIRMATION OBTAINED 20 MINUTES AFTER FIRST SPECIMEN OBTAINED AND BLADDER EMPTIED)	
REFUSAL TO PROVIDE SPECIMEN	
IF EMPLOYEE REFUSES OR IS UNABLE TO SIGN THIS INFORMED CONSENT FORM OR TO SUBMIT TO PROVIDING THE REQUIRED SPECIMENS, A BRIEF DESCRIPTION THE REFUSAL/INABILITY AND THE REASONS WHY (IF KNOWN) SHOULD BE RECORDED ON THIS FORM, SIGNED BY THE COMPANY REPRESENTATIVE/COLLECTOR AND A WITNESS.	
BRIEF DESCRIPTION OF EMPLOYEE REFUSAL/INABILITY TO SIGN OR SUBMIT REQUIRED SPECIMENS:	
COMPANY REPRESENTATIVE/COLLECTOR SIGNATURE	DATE
WITNESS SIGNATURE	DATE

ESSO EXPLORATION & PRODUCTION CHAD INC.



CHAD DEVELOPMENT PROJECT



GENERAL PROJECT SPECIFICATION FOR WASTE MANAGEMENT

GPS-011

Rev. No.	Date	No. of Pages	Prepared By	Reviewed By	Approved By	Revision Details
0	19 Nov 96	10	CKO	PRS	DJS	Issued for Proposals
1	30 Oct 97	10	MEF	PRS	DJS	Issued for EMP

1.0 SCOPE.....3

2.0 DOMESTIC WASTES.....3

3.0 VEHICLE/EQUIPMENT MAINTENANCE WASTES.....4


4.0 CONSTRUCTION DEBRIS.....6

5.0 WATER WELL DRILLING AND COMPLETION WASTES.....7

6.0 START-UP WASTES.....8

7.0 OTHER WASTES.....9

TABLE OF CONTENTS

<p>ESSO EXPLORATION & PRODUCTION CHAD INC.</p>  <p>GENERAL PROJECT SPECIFICATION FOR WASTE MANAGEMENT</p>
--



**GENERAL PROJECT SPECIFICATION FOR
WASTE MANAGEMENT**

1.0 SCOPE

Following are guidelines for waste management applicable during Contractor's performance of the Work. These guidelines provide minimum requirements and suggested waste management methods for each expected major waste type to be generated, and are to be used in preparation of contractor's Waste Management plans as required by Section 30 of the Coordination Procedure - Environmental Management. As indicated in the Coordination Procedure, ESSO will have facilities suitable for hazardous waste disposal in the oil field area in Chad and near the pump stations in Cameroon. Other ESSO approved facilities have yet to be identified.

Waste Management methods for each waste type will be reviewed and approved by ESSO as per Section 30 of the Coordination Procedure - Environmental Management.

2.0 DOMESTIC WASTES

2.1 Waste Water

Depending on the size of the camp and its duration, different types of waste water treatment systems may be applicable. Suitable options may include: 1) an RBC (rotating biological contactor) package plant with effluent discharge to surface waters or a subsurface soil absorption system, or 2) septic tanks with subsurface soil absorption systems. Raw sewage and other waste water will not be discharged into soil or surface water without one of the above treatments (reference GPS-003 (Packaged Sewage Treatment System) and GPS-18 (Septic Tank and Effluent Disposal into Drainage Field (Temporary))) or an ESSO approved alternative. Discharge will be to perennial surface waters, to a subsurface absorption system, or to a surface (e.g., sprinkler) absorption/evaporation system and will be performed in a manner that avoids erosion.

2.2 Water Treatment Sludge

Suitable options for disposal of waste water treatment sludge include: 1) land spreading of the solids with incorporation into the surface soil, or 2) sludge drying beds with landfill disposal or land spreading of dry solids.



**GENERAL PROJECT SPECIFICATION FOR
WASTE MANAGEMENT**

Waste solids should be spread over areas that will need to be revegetated upon camp abandonment rather than clearing additional areas for disposal, when possible.

2.3 Refuse

This category of wastes consists of items from the kitchen, bathroom, laundry, warehouse, etc. Many of these items may be biodegradable, others will be inert. The volume of wastes to be disposed may be minimized by recycling and/or incineration.

Refuse from the camps and work areas will be placed in closed containers and disposed of daily. The disposal method shall prevent attraction of predators and scavengers (i.e., incineration of refuse and landfilling of resulting ash). Reference specifications for incinerators and landfills in this Job Specification.

2.4 Medical Wastes

All medical wastes shall be incinerated by Contractor at its Work Site or transported to an incinerator designated by ESSO. Needles and other sharp objects will be contained in "sharps" disposal containers, and all wastes will be stored and transported in bio-hazard bags prior to incineration. Ash shall be sent to an ESSO approved hazardous waste facility.

3.0 VEHICLE/EQUIPMENT MAINTENANCE WASTES

3.1 Batteries

The preferred management method for batteries is to recycle them. If the vendor will not take the batteries back and no other recycling facilities are available, then the batteries should be stabilized and stored until they can be transported to an ESSO approved facility. Storage facilities shall be designed to provide safe and secure storage, and to prevent site contamination.



**GENERAL PROJECT SPECIFICATION FOR
WASTE MANAGEMENT**

3.2 Tires

Various opportunities exist to recycle tires. Alternatively, tires may be buried or landfilled. Tires occupy a large volume, so opportunities to minimize the volume disposed should be explored (e.g., burning in cement kilns, using ground tires in asphalt paving materials). If buried, measures should be taken to prevent tires from floating to the surface over time.

3.3 Oily Wastes

This category of wastes consists of used lubricants, motor oil, transmission oils, drive grease, cleaning solvents, and any other oily liquids and greases that will be generated while maintaining vehicles and equipment. Used hydrocarbons generated at the pipeline pump stations may be stored, in suitable tanks, for injection into the pipeline when it becomes operational. Another suitable option for oily wastes is incineration or use as supplementary fuel in cement kilns or incinerators. Waste oils shall not be drained onto the ground.

Other oily wastes that will be generated include oily filters and rags. Disposable filters should be drained into a suitable waste oil container before disposal. Suitable options for disposal may include: 1) incineration, or 2) landfill at an ESSO approved facility (at the oil field facilities in Chad or at the pump station locations in Cameroon). Recyclable filters should be used when possible.

3.4 Scrap

Scrap parts will be generated from maintenance activities. The composition of these parts will determine the most suitable disposal option. Metal parts may be recycled or buried (if small), plastic parts may be incinerated and/or landfilled.



GENERAL PROJECT SPECIFICATION FOR
WASTE MANAGEMENT

4.0 CONSTRUCTION DEBRIS

4.1 Vegetation Debris

Suitable options for the disposal of non-commercially valuable vegetation debris include: 1) making the material available to the local population for building materials and fuel, 2) small trees and brush may be chipped and used as a soil amendment or bulking agent for land treatment or composting, or spread over areas to be reclaimed. Burning of vegetation shall be minimized.

4.2 Cement and Concrete Waste

This category of waste includes cement contaminated soils as well as other cement and concrete wastes generated during construction. Waste volumes can be minimized by returning un-reacted cement to the vendor, or using it at the next Work Site. Set materials may be crushed and used as fill or road base material, or buried. Cement contaminated soils may also be suitable for landfill cover.

4.3 Wood

Suitable options for wood debris will be similar to those for vegetation debris.

4.4 Metal

Scrap metal shall be sold to a scrap yard for recycling, if possible. If recycling/reuse is not possible then landfill/burial may be used. If the metal is a container that has been in contact with organic liquids or toxic chemicals (e.g., biocides, herbicides, pesticides, etc.) then it shall be crushed, so that it cannot be used for storage of goods by local people, and sold as scrap or landfilled. Large pieces of metal (e.g., wrecked vehicles, engine blocks) will not be buried.

4.5 Oil Contaminated Soil

Preferred options for treatment and disposal of oil contaminated soils include: 1) treatment in place via bioremediation, 2) excavation for treatment via composting, 3) incineration, and 4) use as supplementary



**GENERAL PROJECT SPECIFICATION FOR
WASTE MANAGEMENT**

fuel in a cement kiln or incinerator (if oil content is >25%). The target for treatment of oil contaminated soil is less than 1 weight percent oil and grease remaining.

4.6 Paint (and Other Coating) Wastes

Suitable options for disposal of solvent based paint/coatings are incineration or use as a supplementary fuel (e.g., in cement kilns or incinerators). Contaminated rags, brushes, and other related wastes may be suitable for landfill if contamination is low. Empty cans shall be crushed prior to disposal. Paint/coatings shall not be drained onto the ground or buried.

5.0 WATER WELL DRILLING AND COMPLETION WASTES

5.1 Drill Solids, Cuttings (Fresh Water)

Drill solids from water based drilling systems should be relatively free of oil. Water based cuttings may be land applied or dilution buried. Alternatively, the solids can be dried and used as landfill cover.

5.2 Cement Contaminated Mud

If contamination is low, treatment with bicarbonate may allow reuse. Alternatively, mud may be used in a mud-to-cement program. Other acceptable options may include land application or dilution burial, or solidification of the mud solids for use as landfill cover.

5.3 Cement and Concrete Waste

This category of waste includes cement contaminated soils as well as other cement and concrete wastes generated during construction. Waste volumes can be minimized by returning un-reacted cement to the vendor, or using it at the next Work Site. Set materials may be crushed and used as fill or road base material, or buried. Cement contaminated soils may also be suitable for landfill cover.



**GENERAL PROJECT SPECIFICATION FOR
WASTE MANAGEMENT**

5.4 Whole Mud (Fresh Water Gel Mud)

As long as the toxicity is low, acceptable options for fresh water gel muds include land application or dilution burial, or solidification of the mud solids for use as landfill cover.

5.5 Workover and Completion Fluids

Appropriate options for disposal of workover and completion fluids will depend upon the characteristics of the fluids and whether surface waters having sufficient flow to dilute constituents and exhibit no impact are available. Options include treatment for surface discharge and treatment for injection into an appropriate reservoir.

6.0 START-UP WASTES

6.1 Oil Contaminated Soil

Preferred options for treatment and disposal of oil contaminated soils include: 1) treatment in place via bioremediation, 2) excavation for treatment via composting, 3) incineration, and 4) use as supplementary fuel in a cement kiln or incinerator (if oil content is >25%). The target for treatment of oil contaminated soil is less than 1 weight percent oil and grease remaining.

6.2 Fuel Oil Filter Sludge

Preferred options for the management of fuel oil filter sludge are composting or land treatment, or incineration.

6.3 Lube Oil Filter Sludge

Preferred options for the management of lube oil filter sludge are composting or land treatment, or incineration.

6.4 Sludges, Slop Oil and Tank Bottoms

The volume of material to be managed can be reduced by reclaiming the oils and recycling them into the crude stream. Remaining oily solids may be composted to reduce oil content, or may be incinerated.



GENERAL PROJECT SPECIFICATION FOR
WASTE MANAGEMENT

6.5 Used Lube Oil Waste

Used lube oil may be stored in crude production wells or tankage until crude is produced, then recycled into the crude stream for processing. Oily solids may be incinerated. Lube oil may also be incinerated or used as supplementary fuel (e.g., in a cement kiln or incinerator). Waste oils shall not be drained onto the ground.

7.0 OTHER WASTES

7.1 Used Solvents

Waste volumes shall be minimized by returning solvents and their containers to the supplier, or using them on the next Work Site where possible. Solvents may also be reclaimed for reuse. Waste solvents may be suitable for incineration or use as supplementary fuel in a cement kiln or incinerator. Solvents shall not be drained onto the ground or buried.

7.2 Drums/Barrels/Containers

Suitable options for disposal of drums, barrels and containers include: 1) returning them to respective vendors for recycling, 2) burial or landfill. Drums, barrels and containers shall not be made available for use by the local population unless removable liners prevented chemical contents from contacting the container walls. If the drums, barrels or containers have been in contact with organic liquids, or toxic chemicals (e.g., biocides, herbicides, pesticides, etc.) then they shall be emptied, crushed and landfilled.

7.3 Incinerator Ash

Ash from incineration of various wastes shall be landfilled. If the original waste had a high metals content, then the ash shall be stabilized to prevent leaching of metals prior to being landfilled.



GENERAL PROJECT SPECIFICATION FOR
WASTE MANAGEMENT

7.4 Water/Sludge from Container Washing

Sludges and contaminated wash waters generated during drum/barrel/container washing operations shall be processed to recover any free oil and separate solids from liquids. Recovered hydrocarbons can be mixed with other used oil wastes. Oily solids may be suitable for composting or land treatment, or may be incinerated. Waste waters containing biodegradable organics may be added to the domestic waste water stream for treatment if volumes are small. Appropriate management will depend upon the substance washed and the resulting concentration in the wash water.

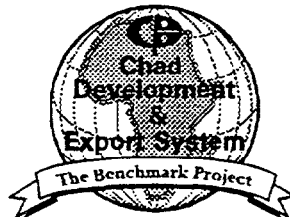
7.5 Hydrottest Fluid

Hydrottest fluid volumes can be minimized by optimizing use/reuse of the fluid as sequential segments of the pipeline are hydrottested. Surface discharge of the hydrottest fluids may be acceptable if the constituents are diluted sufficiently (water treatment may be necessary) to cause no detrimental impact on either surface water resources or ground water that receives the leachate from water discharge over soil. Surface discharge shall be done in a manner that prevents erosion and minimizes impacts on vegetation.

ESSO EXPLORATION & PRODUCTION CHAD INC.



CHAD DEVELOPMENT PROJECT



GENERAL PROJECT SPECIFICATION FOR SOCIOECONOMIC ACTION PLAN

GPS-012

Rev. No.	Date	No. of Pages	Prepared By	Reviewed By	Approved By	Revision Details
0	19 Nov 96	27	CKO	ADM	DJS	Issued for Proposals
1	30 Oct 97	27	MEF	<i>PRG</i>	DJS	Issued for EMP



GENERAL PROJECT SPECIFICATION FOR
SOCIOECONOMIC ACTION PLAN

TABLE OF CONTENTS

1.0 PUBLIC AWARENESS..... 3

1.1 POLICY..... 3

1.2 OBJECTIVE 3

1.3 SCOPE 3

1.4 IDENTIFYING ISSUES..... 4

1.5 LOCAL/NATIONAL PARTICIPATION 4

1.6 SOCIOECONOMIC BASELINE STUDY 5

1.7 ESSO'S REGIONAL AWARENESS PROGRAM..... 5

1.8 CONTRACTOR'S REGIONAL PUBLIC AWARENESS RESPONSIBILITIES 5

2.0 EMPLOYMENT..... 6

2.1 POLICY..... 6

2.2 OBJECTIVES 7

2.3 ISSUES/CONSTRAINTS 7

2.4 ASSIGNMENT OF RESPONSIBILITIES 8

2.5 INFORMATION/COMMUNICATION..... 9

2.6 RECRUITMENT PROCESS 11

2.7 TRAINING..... 14

2.8 TRANSPORTATION AND HOUSING..... 17

2.9 PERSONNEL ADMINISTRATION 18

3.0 BUSINESS OPPORTUNITIES..... 18

3.1 GENERAL OBLIGATIONS 18

3.2 BASIS FOR PLAN 19

3.3 OBJECTIVES 19

3.4 ANALYSIS OF POTENTIAL OPPORTUNITIES..... 19

3.5 ESSO AND CONTRACTOR RESPONSIBILITIES..... 20

3.6 CONTRACTOR RESPONSIBILITIES..... 21

3.7 ESSO RESPONSIBILITIES 22

4.0 LAND USE..... 26

4.1 LAND USE IMPACTS..... 26

4.2 LAND ACQUISITION..... 26

LIST OF TABLES AND FIGURES

Table 1 OPPORTUNITIES FOR LOCAL BUSINESS..... 23



GENERAL PROJECT SPECIFICATION FOR
SOCIOECONOMIC ACTION PLAN

1.0 PUBLIC AWARENESS

1.1 Policy

Esso is committed to providing appropriate, timely and accurate information and will arrange for Local/National consultation concerning the Chad Development and Export System Project for/with individuals, groups, communities, government agencies and other organizations. Esso will conduct direct consultation with local interest groups as the basis for identifying concerns about the project, and responding to them in planning, constructing and operating its Chadian and Cameroonian facilities.

Major Contractors and their sub-contractors shall contractually acknowledge Esso's strong commitment to project socioeconomic goals. Contractors' working contracts must include provision for preparing Public Awareness Procedures consistent with project goals and Esso guidelines.

1.2 Objective

The intent of the Public Awareness section of this Socioeconomic Action Plan is to explain how Esso and its major Contractors:

- identify and respond to project issues that are of concern to Chadian and Cameroonian residents, communities, groups, government agencies and other organizations;
- allow for Local/national participation in addressing issues related to project planning, construction and operations; and
- monitor the project's and Contractors' socioeconomic results.

1.3 Scope

The Public Awareness section of the Socioeconomic Action Plan is based upon a consultation process in both countries that is designed to:

- identify issues;
- achieve local and national awareness of project goals and needs;
- build company relationships; and
- encourage Local/National participation.



GENERAL PROJECT SPECIFICATION FOR
SOCIOECONOMIC ACTION PLAN

1.4 Identifying Issues

The principal method Esso will use to identify issues will be through continued contact with groups and individuals in the communities impacted by the project and with government officials. Through these discussions, information about the project's status will be passed on and issues will be identified. This process will include:

- visits to Chadian/Cameroonian communities to establish contacts, discuss plans, and identify and resolve any concerns that residents and communities may have about the project;
- meetings with Chadian/Cameroonian businesses to determine which services and goods are available and to discuss business opportunities and identify related problems; and
- meetings with various government agencies to identify and resolve government concerns and establish good working relationships.

Esso is willing to meet with legitimate interested groups and individuals, on both a regular and unscheduled basis, to discuss issues of concern arising from the project.

Esso also relies on the results of socioeconomic studies conducted in the local area to identify issues and concerns. Esso will respond in writing to all written formal concerns received.

1.5 Local/National Participation

Esso is committed to constructing and operating the Chad Development and Export System in a way that provides Local/National labor and business with significant opportunities for participation.

Contractors shall be free to choose suppliers, Contractors and subcontractors in order to obtain services of good quality, in connection with every aspect of the Work irrespective of national origin. However, Contractor and its subcontractors shall endeavor to use Chadian/Cameroonian personnel, equipment, and insurers incorporated in Chad/Cameroon, provided that their services and equipment meet the criteria of efficiency, technical capabilities, and financial considerations while remaining comparable to the equipment, material, insurance and services of



GENERAL PROJECT SPECIFICATION FOR
SOCIOECONOMIC ACTION PLAN

foreign origin with regard to price, quality, reliability, availability, and delivery terms.

1.6 Socioeconomic Baseline Study

As part of the Environmental Assessment (EA) process, Esso has completed a Socioeconomic Baseline Study to measure the impact of the Chad Development and Export System Project.

Esso has reviewed the program with government officials of both governments. The EA baseline data has been collected and collated, and submitted to the governments of Chad and Cameroon. The Chadian and Cameroonian governments, in association with the World Bank, will release the EA for public review and comment.

1.7 Esso's Regional Awareness Program

Esso will continue to strive for regional awareness of all aspects of the project through a public information program. This program includes:

- publishing brochures for Chadian/Cameroonian distribution that:
 - describe and explain the planned project,
 - detail job opportunities for Chadian and Cameroonian residents, and
 - explain potential opportunities for Local/National business.
- developing audio visual programs describing the project.
- ongoing consultation with communities, businesses, government and other groups.
- supplying copies of this Socioeconomic Action Plan, and other public documents, when requested to do so.

1.8 Contractor's Regional Public Awareness Responsibilities

Contractor public awareness responsibilities will include, but not be limited to, the following:



GENERAL PROJECT SPECIFICATION FOR
SOCIOECONOMIC ACTION PLAN

- assisting Esso with general consultation and public awareness program.
- preparing public awareness materials and presentations that clearly define local business opportunities and labor needs.
- assisting Esso with the presentation and consultation effort necessary to ensure broad distribution of contract specific materials.
- employing an Employment and Business Coordinator(s) to work with Esso's Employment and Business Coordinator(s).
- being aware of and sensitive to the potential for changes in public attitudes and perceptions that might require additional public awareness action(s). Contractor should develop an internal network that will collect information and provide warning about changing public perceptions. This information should be relayed to Esso through the Employment and Business Coordinator(s).
- working with Esso to develop additional public awareness materials and presentations that address changes in public perception of the project.

2.0 EMPLOYMENT

2.1 Policy

It is the Policy of Esso to provide full and fair employment opportunity in conformance with all applicable laws and regulations of the Republics of Chad and Cameroon, to Nationals who are qualified to perform job requirements.

Esso's policies and procedures will be binding on its Contractors and on their sub-contractors. Companies already licensed to do business in Chad and/or Cameroon will adjust their plans to accommodate their existing work force in the framework of Esso's policies and procedures. Contractor(s) will prepare a detailed employment plan for Esso review and approval before mobilization.



GENERAL PROJECT SPECIFICATION FOR
SOCIOECONOMIC ACTION PLAN

It is Esso's desire, consistent with other reasonable factors such as, cost, availability, and qualifications that Contractors ensure that Chadian/Cameroonian citizens have access to all employment opportunities for which they qualify.

It is incumbent on Contractors to develop a training program that can be reasonably demonstrated to assist in the execution of a cost effective construction project while maximizing local labor involvement, after developing cost data comparing the expense associated with importing expatriate workers to training a Local/National work force.

2.2 Objectives

Esso employment objectives include:

- ensuring that Chadian/Cameroonian citizens have access to all employment opportunities for which they qualify.
- ensuring equitable distribution of employment opportunities giving a priority to communities that are most affected (by the Work) at the Canton and village levels.
- sourcing long term operating staff from the construction work force.
- minimizing impact of work force housing on surrounding communities.

2.3 Issues/Constraints

This plan is designed to overcome limiting factors to attracting qualified Nationals as construction employees of the project's contractors or of Esso. These limiting factors and the mitigation responses to address those limitations are discussed below:

<u>Issues/Constraints</u>	<u>Mitigation</u>
* Inconsistent or non-existent employment training	* Develop training guidelines for Contractor to execute per Section 27 of the Coordination Procedure - Training.



GENERAL PROJECT SPECIFICATION FOR
SOCIOECONOMIC ACTION PLAN

- * No employment infrastructure
 - * Define hiring policy and process and Esso versus Contractor roles.
 - * Establish Esso and Contractor's Employment and Business Coordinator(s) in Chad and Cameroon to facilitate the recruitment process.
- * Differing cultures and lifestyles
 - * Based on survey identifying cultural/lifestyle issues prepare cross-cultural training requirements for expatriate group as well as National group.
- * Unrealistic expectations of local people in terms of job availability and duration
 - * Communicate with government and community leaders, local population, to diffuse issue.

The following sections discuss specific plans to meet the objectives, taking into account the constraints Esso has identified.

2.4 Assignment of Responsibilities

2.4.1 Esso Responsibilities through the Employment and Consultation Office

Esso will establish an Employment and Consultation Office (ECO) in N'Djamena - Chad and in Douala - Cameroon. In both places the office will be staffed with an Esso Employment and Business Coordinator(s).

The ECO will be responsible for:

- Providing individuals, groups and the government with information about the number and types of jobs available and when people will be needed to fill them. This information will be based on Esso's own needs as well as Contractors' needs as outlined in their employment plan. This information program is described in a following section.
- Implementing the pre-selection process for the national recruitment of Esso and Contractor employees. The deliverable of this process will be a list of potential candidates for the different Contractors' job positions. Final selection from this list will remain with Contractor.



GENERAL PROJECT SPECIFICATION FOR
SOCIOECONOMIC ACTION PLAN

- Ensuring that Contractors' plans and programs are in place for hiring and training Nationals -- including program monitoring.
- Consolidating the personnel tracking database of the different Contractors and sub-contractors as detailed in a subsequent section, in order to provide information for sourcing long term Esso operating staff from the construction work force.

2.4.2 Contractor Employment Responsibilities

Contractor(s) will develop an employment plan consistent with Esso's employment policies as discussed in this document. Contractor's plan will include:

- identifying positions to be filled by Nationals,
- defining the hiring mechanism which will interface with Esso's screening process,
- developing a training program and outlining provisions for care and administration of staff and labor.
- designating an Employment and Business Coordinator(s) to interface with Esso's Employment and Business Coordinator(s).
- developing a personnel tracking system that will catalog and retrieve employee information to include all project work history from hiring through termination. The system shall include, as a minimum, pre-employment screening, personnel evaluations, training programs completed, salary history and final termination papers.

2.5 Information/Communication

2.5.1 Job Opportunity Presentations

Based on Esso's own work force requirements and Contractor's employment plan, reviewed and accepted by Esso prior to



**GENERAL PROJECT SPECIFICATION FOR
SOCIOECONOMIC ACTION PLAN**

mobilization, Esso's Employment and Business Coordinator(s) with the assistance of Contractors' Employment and Business Coordinator(s) will meet with individuals and groups in their communities to provide audio visual presentations explaining the main features of the project and the requirements of construction, operations and maintenance positions.

Job opportunity briefings will include:

- job duties and responsibilities,
- labor schedule showing when the jobs will be required,
- number of people required for each position,
- qualifications required for each job, and
- appropriate training for the different positions.

During the course of these presentations, the representatives of Esso and Contractor(s) should be ready to explain what potential workers can expect from project employment in terms of pay, compensation and working conditions. During the presentations, Esso's and Contractors' representatives will clearly indicate:

- the finite number of construction jobs,
- the duration of the construction project, and
- the smaller but longer term number of operations and maintenance positions.

This should help diffuse any unrealistic expectations regarding employment.

2.5.2 Promotional Programs

To reinforce its information program and employment plan and encourage qualified Nationals to take advantage of job opportunities, Esso's Business and Employment Coordinator(s) will use local and national media to:

- Recruit locally for unskilled positions. Esso, in cooperation with local authorities, would arrange local employment meetings and arrange for advertising in local newspapers, local radio stations and on bulletin boards.
- Advertise nationally employment opportunities for the higher skilled positions on radios and newspapers.



GENERAL PROJECT SPECIFICATION FOR
SOCIOECONOMIC ACTION PLAN

2.5.3 Presentation Cycle

The information program will be implemented on-site between contract award and site mobilization.

Sequentially, there will be Prefecture meeting, Sous Prefecture meetings, Chef-lieu de Canton meetings, and one to two village meetings per Canton for the administrative areas impacted by the project. An impacted administrative area is a region, a Canton or a village/commune which will host production facilities, the pipeline right-of-way, pipeline pump stations, storage yards, camps or other project related Work Sites.

2.6 Recruitment Process

2.6.1 Local Work Force

A Local is defined as a permanent resident of the project area (less than a one hour commute to the Work Site). Locals will be made aware of the job opportunities in the presentations made in the "Chefs lieux de Canton" and village meetings of the impacted areas.

Following up on those meetings, Esso's Employment and Business Coordinator(s) will ask "Chefs de Canton" and the local clergy to work together to provide a list of potential candidates from their Canton, broken down by villages. Candidates should be in good physical condition, and live in those villages. Each list will include:

- name of candidates,
- age and residence,
- mother language, preferably French speaking, and
- any skill that could be helpful in the project: technical skills, previous work experience.



GENERAL PROJECT SPECIFICATION FOR
SOCIOECONOMIC ACTION PLAN

It is expected that unskilled positions will be filled by local workers (as defined above) and that Esso will identify some candidates for more skilled positions in the local population. The description of the next steps are mainly addressing the laborers' screening prior to hiring.

Based on the work force demand of Esso and its Contractors for fixed Work sites (Field Facilities, main camps of Pipeline, Pump Stations, Logistics yards), the Esso Employment and Business Coordinator(s) will equitably allocate unskilled positions between the impacted Cantons (e.g., Field Facilities construction will straddle five Cantons: MIANDOUM, DOBA, BERO, KOME, BEBEDJA). Allocations within each Canton will be decided after consultation with local authorities (i.e., Prefets, Sous Prefets, and Chefs de Canton).

For mobile work sites like the pipeline and infrastructure spreads, equitable distribution of employment opportunities between the impacted Cantons will apply to the cross-section of employees for a full work season regardless of whether Contractor hires all the employees at once for the season or hires them for short work contracts as the work progresses. The two alternatives are possible and Contractor should propose the most efficient one without compromising Esso's socioeconomic objectives.

From the list of potential candidates and hiring guidelines provided by Esso's Employment and Business Coordinator(s), Contractor(s) will select its personnel. Contractor will propose a selection/hiring process which will:

- Verify information included in the Cantons lists when candidates are interviewed. Candidates will provide proof of identification (ID card) and police clearance.
- Include a medical examination performed by a doctor or a paramedic per Coordination Procedure 23 - Occupational Health, Medical Facilities and Sanitation.
- Define the skill evaluation phase. The test, evaluation, classification will be performed by personnel familiar with the local cultures.



GENERAL PROJECT SPECIFICATION FOR
SOCIOECONOMIC ACTION PLAN

- Define the final monitoring process to comply with the allocation required by Esso.

The screening decision will be documented for each candidate whether the candidate is selected or discarded.

Esso's Employment and Business Coordinator(s) will meet as often as necessary with Contractor's Employment and Business Coordinator(s) to steward the process and address issues that will arise in the course of the hiring process.

When higher skill candidates are identified from the lists provided by the Cantons' chief, their screening and selection will be that of the non-local workers described below.

2.6.2 Regional and National Work Force

A local resident has been defined in Section 2.6.1, "Local Work Force." Regional individuals are residents of the administrative "Departments" where the given facilities are sited (e.g., "Ocean Department" in Cameroon with Kribi as the Prefecture).

It is expected that the majority of the semi-skilled positions and some skilled positions will be filled by Nationals.

Esso will develop and implement a program that advises on the quantity and duration of project employment opportunities through National media advertising and local information meetings. Contractors' Employment and Business Coordinator(s) will be in contact with potential candidates.

Each candidate will be asked to complete and submit an application which will include personal information (including proof of ID), academic background, skill training and work experience.

The role of Esso's Business and Employment Coordinator(s) will be to:

- Develop and steward the media program.
- Ensure wide distribution of employment information in critical public places.



GENERAL PROJECT SPECIFICATION FOR
SOCIOECONOMIC ACTION PLAN

- Provide counseling on how to apply for employment.
- Review Contractor's list of potential employment candidates.

Contractor's Employment and Business Coordinator(s) shall:

- Screen and eliminate unqualified candidates.
- Prepare and propose lists of potential candidates by positions. This will take into account Contractor's training program which should upgrade the skills of some of the Local/National laborers.

Contractor will select its personnel from the pre-selection lists, which should be ready at the start of site mobilization. Contractor will provide in its Employment Plan a selection process in conformance with guidance provided in Section 2.6.1, "Local Work Force." However, for higher skilled positions for which a nationwide recruitment plan will be necessary, the first preference will be given to qualified local residents who apply for jobs, then qualified regional workers, before considering other National candidates.

The screening decision will be documented for each candidate and Esso's Employment and Business Coordinator(s) will work with Contractors' Business and Employment Coordinator(s) to address issues arising in the course of this selection.

2.7 Training

2.7.1 Scope

It shall be the responsibility of Contractor to develop and administer a Training Program to meet project training requirements. This program will be designed to accomplish multiple objectives and will be executed in two phases.

Phase 1 training will be designed to orient the work force at mobilization and will accomplish several tasks. First, the training program will develop basic skills in topics such as health and safety for the newly hired National work force. Second, the training program will provide basic crafts skills training for the



**GENERAL PROJECT SPECIFICATION FOR
SOCIOECONOMIC ACTION PLAN**

unskilled work force. Finally, the training program will provide cross cultural awareness training for all workers, Nationals and expatriates. Contractor shall provide counseling to assist National workers in adjusting to industrial work conditions.

In the interest of providing local labor for long term operations needs, Phase 2 training will be designed to advance worker skills from the basic level to the semiskilled or skilled level. Guidance for preparing Phase 2 plans is included in Coordination Procedures Section 27 - Training.

2.7.2 Contractor's Employment Orientation Plan

Esso's Contractor(s) shall be responsible for training its work force. Minimum standards set by Esso, and discussed below shall be followed by all major project Contractors. Contractor shall submit to Esso for review within ninety (90) days of Contract award a Training Plan which includes:

- Documentation of Contractor's compliance with hiring guidelines provided by Esso to ensure equitable distribution of project employment across tribal/cultural and civil boundaries.
- A comprehensive description of all planned training activities covering the following topics: environmental, health, safety, security, community awareness and fire protection. Descriptions shall include course content, course attendees and testing and verification methods.
- A description of the TRAINING tracking program and the records system which documents all employee orientation and construction training.

As part of the orientation process Contractor shall supply each new employee to be working in construction areas with a full set of work clothes including one (1) pair of safety shoes, (1) hard hat, (1) pair safety glasses and (1) pair of ear protection devices, three (3) pair of socks, two (2) trousers, and three (3) shirts. The clothing shall be supplied annually by Contractor and shall require the approval of Esso.



GENERAL PROJECT SPECIFICATION FOR
SOCIOECONOMIC ACTION PLAN

2.7.3 Contractor's Skills Training Plan

Consistent with Esso objectives of maximizing the use and training of Local/National employees without sacrificing cost effectiveness or quality of workmanship, Contractor shall develop a skills training plan that allows participation of the largest segment of the Chadian and the Cameroonian work force possible. Contractor's plan should address, at a minimum, the following issues:

- Contractor shall conduct a survey of labor availability within the regional area of their work responsibility prior to startup to determine the availability of skilled, semi-skilled and unskilled labor (appropriate for those positions germane to its Scope of Work) and make available to Esso the results/conclusions of this survey.
- Contractor shall develop a craft work force profile for each regional area of their work responsibility. This information is to be used in the hiring process and the development of the Training Plan.
- Contractor shall implement an Esso approved Training Program for skilled and semi-skilled National/Local hire craft training and certification which includes helpers, craftsman and foreman.
- Contractor shall pay the Local/National hires prevailing wage during their participation in the approved Training Program.
- Contractor shall develop an on-the-job training program (OJT) which prepares National/Local hire workers for advancement and promotion to higher skill levels.
- Contractor shall maintain a file on each Local/National hire which will include an evaluation schedule, certification, and promotion record. This information is to be made available to Esso upon request.



**GENERAL PROJECT SPECIFICATION FOR
SOCIOECONOMIC ACTION PLAN**

- Contractor shall maintain a file of Training Program compliance with local, regional and country labor laws and regulations. Records of compliance shall be made available to Esso upon request.
- Contractor shall provide a training facility which is to be equipped with the standard tools and materials needed to provide training in those crafts germane to its Contract.
- Contractor shall supply each trainee, including helper, craftsman, and foreman, a basic tool kit of the craft in which the trainee is receiving training.

2.8 Transportation and Housing

Transportation and housing principles described for implementation in this section are based on local availability (i.e., work force supply and existing housing available) and distance from work site. Those principles are also based on previous experience of petroleum exploration projects in the Chad Doba area, the most recent one being the 3D seismic program of 1995/96.

Contractor will provide, or make available, daily commuting transportation to workers living away from the work site. Pickup and return shall be at central points in multiple villages as necessary. One hour commuting one way is considered as being acceptable from an efficiency and safety standpoint.

If the work site moves during the work season, Contractor will establish a mobile bachelor housing camp for non-local workers. The quality of the accommodations is described in the Camps and Facilities Specification and the Catering Services Specification.

For the housing of non-local workers for fixed work sites and road upgrade work (infrastructure contract) whose homes are more than one-hour commuting from the work sites Contractor may choose to:

- House the workers in a camp, or
- Work with the community, local entrepreneurs and Esso to ensure that adequate housing and facilities are available in the local community to accommodate workers without displacing or adversely affecting the existing population or the environment or



**GENERAL PROJECT SPECIFICATION FOR
SOCIOECONOMIC ACTION PLAN**

overloading existing infrastructure. In this case, Contractor will provide the non-local workers with a housing allowance. Esso's Employment and Business Coordinator(s) will facilitate finding a solution for the specific fixed work sites (for example, Field Facilities in Chad, Pump Stations and Pipeline main camp sites in Cameroon).

2.9 Personnel Administration

In its employment plan, Contractor will describe the way it will administer its Local and National personnel:

- Method of employee payment (how, when, where to pay employees); minimum wages consistent with current in-country practices.
- Compliance with national labor code.
- Free medical assistance for on-the-job injuries and illness.

Contractor's decision on whether to provide rotational shifts for non-local Nationals will be governed by such factors as relative efficiencies of short term non-rotational hiring versus long term housing with rotating shifts.

Contractor will, starting at the hiring phase, develop a tracking system for the experience, training, different positions, and performance evaluation of each construction worker for potential operations employment. Contractor will develop this database with Esso's Employment and Business Coordinator(s).

3.0 BUSINESS OPPORTUNITIES

3.1 General Obligations

Esso is committed to constructing and operating the Chad Development and Export System Project in a way that provides Local/National businesses with significant opportunity. Note that a Local/National business is defined as one that is currently registered in the country (Chad or Cameroon), has an active local presence (office) and a recent history of successfully completed work.



**GENERAL PROJECT SPECIFICATION FOR
SOCIOECONOMIC ACTION PLAN**

Esso's policies and procedures, as they pertain to Chad Development and Export System Project participation, will be binding on its Contractors, and on their subcontractors.

Esso's policy covering Contractor's use of Chadian/Cameroonian providers of goods and services is covered in the Principal Document. Esso will not pay premiums to Chadian/Cameroonian businesses solely to achieve National participation.

3.2 Basis for Plan

Esso's business opportunity plan is based on:

- the considerable experience that the company has gained with prior development projects,
- advice from government and non-government agencies, and
- consultation within the Chad Development and Export System Project community.

3.3 Objectives

Consistent with Esso's policies, Esso's business opportunity plan is designed to:

- recognize qualified and competitive local and national businesses,
- foster National businesses that will be able to supply high quality goods and services required by Esso's Chadian/Cameroonian operations at the lowest total cost both in the near and long term, and
- provide support for Esso's and Contractor's proposed plans for housing labor.

3.4 Analysis of Potential Opportunities

Esso's analysis of the work indicates significant potential for the Chad Development and Export System Project to positively impact the Chadian and Cameroonian economy. This estimate is based on the type



**GENERAL PROJECT SPECIFICATION FOR
SOCIOECONOMIC ACTION PLAN**

of skills and services that Esso has been able to identify as opportunities and the likelihood that the Chadian and Cameroonian populace will respond favorably.

A list of likely areas for Local/National business involvement in the Chad Development and Export System Project is presented in Table 1.

3.5 Esso and Contractor Responsibilities

To stimulate and facilitate involvement of Chadian/Cameroonian entrepreneurs and businesses, Esso and Contractor(s) will provide Employment and Business Coordinator(s) for Chad and Cameroon. The Esso and Contractor coordinators will work together to accomplish the following tasks:

- develop and maintain an information system on Chad Development and Export System business opportunities, including required qualifications and work experience;
- liaise between interested Local/National businesses and Esso/Contractor groups involved in planning and developing segments of the Project. This will include developing and conducting business and contracting seminars for Local/National businesses that:
 - outline Chad Development and Export System Project opportunities,
 - inform Chadians and Cameroonians of how they might approach Esso/Contractor to become involved in the project, and
 - detail contracting and procurement policies and procedures (bidding process and documents, contracts, purchase orders and invoicing);
- develop and maintain a list of potential Local/National suppliers for Project goods and services;
- periodically visit Chadian and Cameroonian communities to provide information and discuss local business needs and concerns;



GENERAL PROJECT SPECIFICATION FOR
SOCIOECONOMIC ACTION PLAN

- review and steward the goods and services procurement plan developed by each Contractor. This will include developing and issuing periodic Business Opportunities Brochure which will list the goods and services required for the Project for the upcoming year; and
- monitor Contractor/subcontractor bidders lists and resulting use of Local/National entrepreneurs and businesses to verify that qualified Nationals are offered a fair chance to participate and to identify areas where Local/National content can be increased without increasing Project cost.

3.6 Contractor Responsibilities

In addition to the responsibilities outlined above, Contractor shall:

- Prepare a Local Business Opportunity Plan that accomplishes the stated objectives of the Esso Plan.
- Survey Chad and/or Cameroon (as applicable) to identify and quantify the availability of local Contractors with products/services useful to its work (adding to the list supplied by Esso).
- Provide by 1 October and 1 April of each year an annual forecast of goods and service needs which could be filled by Local/National entrepreneurs and businesses in the following calendar year.
- Establish a formal process to ensure use of local Contractors/suppliers is optimized. Maintain data on contracting and procurement activity that can be used to verify that Contractor has complied with requirements.
- Subdivide the subcontract service and supply opportunities into small packages that are compatible with the capabilities of Chadian and Cameroonian businesses, where practical.
- Provide as much lead time as possible and reasonable for subcontractor bid preparation (normal lead time is expected to be one month).



**GENERAL PROJECT SPECIFICATION FOR
SOCIOECONOMIC ACTION PLAN**

- Qualify and select **COMPETITIVE** Local/National Contractors.
- Debrief unsuccessful bidders on request, indicating why their bids were not successful, while retaining the confidentiality of other bids.

3.7 Esso Responsibilities

In addition to the responsibilities described in 3.6, Esso will:

- Provide an unscreened list of potential Local/National businesses and suppliers for Contractors to use.
- Audit Contractor business files to verify compliance in the sub-contracting and procurement process.
- Maintain the right to approve selection of all subcontractors as per the approved source list discussed in Coordination Procedure 14 - Subcontracting.
- Compile Project-wide reports for government review, detailing efforts to involve local businesses.



GENERAL PROJECT SPECIFICATION FOR
SOCIOECONOMIC ACTION PLAN

TABLE 1
OPPORTUNITIES FOR LOCAL BUSINESS

PROFESSIONAL SERVICES

DESCRIPTION

land survey	registered surveyors to stake facilities and pipeline
insurance	
legal	
advertising	
accounting	
lab analysis	on and off-site testing
printing	brochures, forms, etc.

TRANSPORTATION SERVICES

DESCRIPTION

truck transportation	material from storage yards to site(s)
rail transportation	project materials and workers
air transportation	expatriate transportation to and from work sites
bus transportation	daily transportation of local workers to and from work sites
marine transportation	project materials and workers to offshore facilities
travel agent	
hotel accommodations	
restaurant	
equipment rental	leasing cars, light vehicles, etc.

CONSTRUCTION SERVICES/GOODS

DESCRIPTION

site clearing pipeline right-of-way maintenance & erosion control	removing trees, brush, shrubs from roads, work and storage areas, facilities (gathering stations & central treating facilities), camps, pipeline and pump stations, reconditioning of sites and roads after facilities/pipeline installation
dust control	application of water or other dust control materials on roads

CONSTRUCTION SERVICES/GOODS

DESCRIPTION

ESSO EXPLORATION & PRODUCTION CHAD INC.



GENERAL PROJECT SPECIFICATION FOR
SOCIOECONOMIC ACTION PLAN

(Continued)

road construction and maintenance	construction and maintenance of haul road, access road and air strips
gravel and rock hauling	hauling of rock and gravel from quarry stock piles to area of placement for slope protection, pipeline river crossings, road construction, facilities site preparation
electrical, mechanical, instrumentation	installing well tie ins, electrical power supply to telecom towers, pipeline valve sites, cathodic protection
general construction	constructing masonry type buildings (including plumbing, electricity) and landfills (operation of landfills)
equipment rental/purchase	air conditioning, tools, welding machines

MISCELLANEOUS SERVICES

DESCRIPTION

residential homes and apartments	supplying residential homes and apartments during and after construction
camp security	providing security guards for temporary or permanent facilities
water wells	drilling/digging water wells in camps, facilities
cathodic protection and anode installation	cathodic protection wells along pipeline
painting	supplying and applying paint on vessels, piping, building, and tanks
camp and office cleaning	cleaning office and camp facilities
fuel distribution	
facilities fences	providing, installing, maintaining fences around temporary (construction, pipe yards) and permanent sites
catering	catering for camps (temporary or permanent)
disease vector control	spraying in vicinity of camps and permanent work sites
office	providing office space during construction and after
photographic	still and video photography and developing
scrap metal recycling	

MISCELLANEOUS SERVICES

(Continued)



GENERAL PROJECT SPECIFICATION FOR
SOCIOECONOMIC ACTION PLAN

stevedoring

miscellaneous

supplying services such as third party consulting
(solicitor, inspection, water analysis), laundry, dry
cleaning services, clerical, employment agencies,
mail delivery

MISCELLANEOUS GOODS

DESCRIPTION

computer hardware and software

office/household furnishings

stationary/office supplies

fuel and lubes

industrial gases

masonry blocks

for construction facilities building

cement

laterite

raw lumber and lumber supplies

food stuffs

vegetables, fruits and meat for temporary and
permanent camps

general merchandise

retail supplier



GENERAL PROJECT SPECIFICATION FOR
SOCIOECONOMIC ACTION PLAN

4.0 LAND USE

4.1 Land Use Impacts

Conversion of land from farming, grazing, fallow, and bush to oil production has the potential to create adverse social and economic impacts to rural households. Three levels of land use impacts are expected to occur:

- Temporary conversion of land for pipeline and facility construction resulting in the loss of one to two years' plantings, but no displacement of households.
- Permanent loss of a portion of land holdings at facility sites (including fallow and bushlands), impairing, but not eliminating, the economic viability of a household.
- Permanent loss of land that results in household resettlement.

4.2 Land Acquisition

Esso's and Contractor's responsibilities may vary depending upon the country in which work is to be performed.

In Cameroon, the Government has assumed responsibility for pipeline right-of-way and pump station facilities land acquisition. In general, permanent utilization of land resources in Cameroon is simplified because a large amount of project land use is temporary and will return to the owners at the close of construction activities.

In Chad, the government has designated the Operator as the land purchaser. Facilities construction land requirements are, in general, permanent, which therefore may complicate and lengthen the land acquisition process.



GENERAL PROJECT SPECIFICATION FOR
SOCIOECONOMIC ACTION PLAN

4.2.1 Esso Responsibilities


All contact with Chadian and Cameroonian authorities will be through the Esso representative.

Esso will make available construction workspace for the following activities:

- Pipeline Construction
- Access Roads
- Pump Station Construction
- Pressure Reducing Station
- Storage and Camp Sites
- Landfill Sites (Permanent)
- Landfill Sites (Temporary)
- Airstrips
- River, Road and Railroad Crossings

4.2.2 Contractor Responsibilities

- Establish the above mentioned sites for Work activities involved.
- Maintain the sites in accordance with the Contract specification(s) governing these sites.
- Comply with all government statutes and regulations regarding the execution of the contract scope of work.
- Be responsible for all reinstatement work to the satisfaction of the Esso representative.
- Finalize right-of-way post construction damage claims to the Esso representative's satisfaction.

ESSO EXPLORATION & PRODUCTION CHAD INC. 	WASTE INCINERATOR	CCS 7-1-10 Page 1 of 12	
TECHNICAL SPECIFICATION		Rev. 0	04 Nov 96

CHAD DEVELOPMENT PROJECT

TECHNICAL SPECIFICATION

Rev. No.	Date	No. of Pages	Prepared By	Reviewed By	Approved By	Revision Details
0	4 Nov 96	12	FRE	PRS	MAS	IFP Issue


ESSO EXPLORATION & PRODUCTION CHAD INC. 	WASTE INCINERATOR	CCS 7-1-10 Page 2 of 12	
TECHNICAL SPECIFICATION		Rev. 0	04 Nov 96

TABLE OF CONTENTS

1.0 SCOPE 3

2.0 SUMMARY OF ADDITIONAL REQUIREMENTS 4

3.0 DOCUMENTATION 5

4.0 DESIGN/CONSTRUCTION FEATURES..... 5

5.0 MATERIALS 11

6.0 FABRICATION 11

7.0 INSPECTION AND TESTING 11

8.0 INSTALLATION..... 12

9.0 PERFORMANCE..... 12

10.0 OPERATIONS MANUALS..... 12

LIST OF TABLES

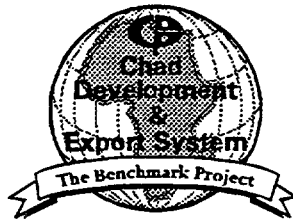
TABLE 1..... 3

TABLE 2..... 6

ESSO EXPLORATION & PRODUCTION CHAD INC.



CHAD DEVELOPMENT PROJECT



GENERAL PROJECT SPECIFICATION FOR SEPTIC TANK AND EFFLUENT DISPOSAL INTO DRAINAGE FIELD (TEMPORARY) GPS-018

Rev. No.	Date	No. of Pages	Prepared By	Reviewed By	Approved By	Revision Details
0	19 Nov 96	15	EHW	CKO	DJS	Issue for Proposals
1	30 Oct 97	15	MEF	JRS	DJS	Issue for EMP



GENERAL PROJECT SPECIFICATION FOR
SEPTIC TANK AND EFFLUENT DISPOSAL INTO DRAINAGE FIELD

TABLE OF CONTENTS

1.0 SCOPE..... 3

2.0 SUMMARY OF ADDITIONAL REQUIREMENTS 3

3.0 SEPTIC TANK SYSTEMS 4

4.0 LEACH FIELD DRAINAGE SYSTEM 6

5.0 DISTRIBUTION NETWORK 10

6.0 PERFORMANCE TESTS FOR SEPTIC TANKS 12

7.0 MATERIALS FOR CONSTRUCTION OF SEPTIC TANK AND LEACH FIELD
PIPING..... 12

8.0 CURTAIN DRAINS..... 13

9.0 CLOSURE OF SEPTIC TANK AND DRAINAGE FIELD SITE 13

LIST OF TABLES AND FIGURES

TABLE 1. CODES AND STANDARDS..... 3

TABLE 2. SEPTIC SYSTEM SETBACKS 6

TABLE 3. LEACH METHOD APPLICABILITY 7

TABLE 4. TRENCH AND BED DESIGN CRITERIA 9

TABLE 5. TRENCH DIMENSIONS 10

FIGURE 1 DISTRIBUTION BOX LEACH FIELD FOR LEVEL/GENTLE SLOPING
SITES 14

FIGURE 2 SERIAL DISTRIBUTION LEACH FIELD FOR SLOPING SITES..... 15



**GENERAL PROJECT SPECIFICATION FOR
SEPTIC TANK AND EFFLUENT DISPOSAL INTO DRAINAGE FIELD**

1.0 SCOPE

This specification covers mandatory requirements for the design, installation and materials for septic tanks, leach fields and curtain drains for domestic sewage treatment and disposal.

2.0 SUMMARY OF ADDITIONAL REQUIREMENTS

2.1 Table 1 lists the specifications, codes and standards which shall be used with this specification.

TABLE 1. CODES AND STANDARDS

American Society of Testing and Materials (ASTM) Standards	
A 53	Pipe, Steel, Black and Hot Dipped, Zinc Coated, Welded and Seamless
C 890	Minimum Structural Design Loading for Monolithic or Sectional Precast Concrete Water and Wastewater Structures
C 1227	Precast Concrete Septic Tanks
D 2321	Underground Installation of Thermoplastic Pipe for Sewers and Other Gravity-Flow Applications
D 2729	Poly(Vinyl Chloride) (PVC) Sewer Pipe and Fittings
F 405	Corrugated Polyethylene (PE) Tubing and Fittings
F 412	Terminology Relating to Plastic Piping Systems
F 449	Subsurface Installation of Corrugated Thermoplastic Tubing for Agricultural Drainage or Water Table Control
F 758	Smooth-Wall Poly(Vinyl Chloride) (PVC) Plastic Underdrain Systems for Highway, Airport and Similar Drainage
F 789	Type PS-46 Poly(Vinyl Chloride) (PVC) Plastic Gravity Flow Sewer Pipe and Fittings

2.2 The local approving authority (local health departments, etc.) shall be contacted regarding septic tank specific requirements for leach field design materials and their installations.

2.3 The septic tank and drainage field shall be designed to handle the load capacity of 360 liters (95 gallons) per capita per day.



GENERAL PROJECT SPECIFICATION FOR
SEPTIC TANK AND EFFLUENT DISPOSAL INTO DRAINAGE FIELD

3.0 SEPTIC TANK SYSTEMS

- 3.1 Septic tanks shall be buried, watertight receptacles designed to receive wastewater (discharge from toilets, kitchens, baths, showers, laundry facilities and sinks) from camp facilities. The septic tank separates solids from liquids, provides limited digestion of organic matter, stores solids and allows the clarified liquid to discharge for further treatment and disposal.
- 3.2 Septic tanks may be cylindrical or rectangular in shape. Septic tank design criteria shall be the following:
- a. Adequate sludge storage shall be provided to prevent settleable solids from flowing into the outlet pipe.
 - b. Air scum volume above the liquid shall be at least 12.5% of the liquid volume but not less than 230 mm (9 in.) high for the entire surface above the liquid.
 - c. Inlet baffle/inlet tee shall direct the flow downwards to prevent the scum layer from plugging the inlet. The inlet baffle/inlet tee shall extend at least 450 mm (18 in.) below the water line but not more than 40% of the water depth. The inlet baffle/inlet tee shall be at least 150 mm (6 in.) above the water line. The top of the tee shall be a minimum of 50 mm (2 in.) below the underside of the tank cover.
 - d. Outlet baffle/outlet tee shall retain the floating scum layer and prevent scum from entering the outlet pipe. The outlet baffle/outlet tee shall extend at least 450 mm (18 in.) below the water line but not more than 40% of the water depth. The outlet baffle/outlet tee shall extend 150 mm (6 in.) above water level.
 - e. Retention period shall be not less than 48 hours at maximum sludge depth and scum accumulation.
 - f. Surface area to depth ratio for all chambers shall be maximized. The ratio shall be greater than 2.0.
 - g. Vents shall be provided to allow the escape of methane and hydrogen sulphide gas.



**GENERAL PROJECT SPECIFICATION FOR
SEPTIC TANK AND EFFLUENT DISPOSAL INTO DRAINAGE FIELD**

- h. Access to the tank interior shall be provided for inspection and cleaning.
- i. Septic tank capacity shall have a safety factor of two to three times the daily design flow.
- j. Grease traps shall be installed upstream of septic tanks to remove grease before wastewater enters the tanks. Grease retention capacity in kilograms shall be at least equal to 25% of the flow capacity in l/min (grease retention capacity in pounds shall be at least equal to twice the flow capacity in gallons per minute).
- k. Invert of the outlet pipe from the septic tank shall be a minimum of 100 mm (4 in.) above the invert of any distribution pipe in the leach field.
- l. The diameter of both the inlet and outlet lines should be the same, and should be a minimum of 100 mm (4 in.).

3.3 The following shall be provided for the top slab:

- a. Access openings in chamber to permit inspection, pump-out and sludge removal.
- b. Covers with plastic or epoxy-coated steel bar handles shall be provided for the openings. Covers must be prevented from moving laterally if sitting on top of the slab.
- c. Locks for covers that are flush with or above the ground to prevent unauthorized access to the septic tank.
- d. If the tank slab is below grade it shall have a minimum soil cover of 300 mm (12 in.) and manhole risers shall be provided to raise access openings 150 mm (6 in.) above finish grade elevation.
- e. Where access opening or an inspection opening has a dimension greater than 200 mm (8 in.) a label of non-corrosive material shall be placed in a prominent place to warn everyone, in French and English, that "Entrance into the Tank could be Fatal."

3.4 Minimum setbacks for septic tank systems are shown in Table 2.



**GENERAL PROJECT SPECIFICATION FOR
SEPTIC TANK AND EFFLUENT DISPOSAL INTO DRAINAGE FIELD**

TABLE 2. SEPTIC SYSTEM SETBACKS

Features	Distance Septic Tank (meters)	Distance To Leach Field (meters)
Building (Outside Wall Face)	3.0	10.0
Property Boundary	3.0	3.0
Surface Water	15.0	15.0
Cut or Embankment	8.0	60.0
Nearest Dug Well or Other Source of Domestic Water Supply	60.0	100.0
Water Service Pipes	3.0	8.0
Walks and Drives	2.0	2.0
Large Trees	3.0	3.0

3.5 Septic tanks shall be designed for loads in accordance with ASTM C890. If the septic tank is located in an area where there is access to traffic then the septic tank shall be designed for an AASHTO HS-20 Load.

4.0 LEACH FIELD DRAINAGE SYSTEM

4.1 The leach field drainage system shall be sited and designed to provide the physical, chemical and biological environment necessary for the wastewater renovation through the soil. Major factors which shall be considered in the design of leach fields include the following:

- a. Local soil conditions; soil characteristics including texture, structure, stratification, bulk density, grain size distribution and coefficient of permeability.
- b. Depth of bedrock and presence of bedrock fissures or fractures.
- c. Saturated soil and high groundwater table; the groundwater table must be a minimum 1 m (3 ft.) below the bottom of the leach field trench.
- d. Surface slope.
- e. Presence of ponding and/or flood conditions.
- f. Per capita sewage flows.
- g. Design life of the system.



**GENERAL PROJECT SPECIFICATION FOR
SEPTIC TANK AND EFFLUENT DISPOSAL INTO DRAINAGE FIELD**

4.2 The design of the leach field system shall consider that soil bacteria break down soluble organic pollutants and that physical filtering action of the soil removes suspended particles, including sewage borne bacteria and viruses. This action causes the production of slimy films of bacteria on the soil particles in the leach fields. In naturally well drained soils such as sand, sandy loam and loamy textures, the crust (slimy film) impedes the flow of water into the soil horizons and will be unsaturated and aerobic. This results in an increase of the contact time with the soil and ultimately of the treatment efficiency. Clay soil, on the other hand, would be nearly saturated and anaerobic and hence would require greater trench length to achieve a satisfactory treatment.

4.3 Percolation Test

4.3.1 The percolation characteristics of the soil shall be used to determine the ability of the soil to perform as a leach field. A minimum of four separate tests shall be carried out in four holes spaced uniformly over the proposed leach field. If the test results are not consistent within $\pm 30\%$, additional tests in different locations may be required by ESSO.

4.3.2 Leach fields shall consist of conventional trenches and beds, or disposal mounds or a combination thereof based on the geotechnical conditions and field survey information. Table 3 provides a guide for the selection of disposal methods under various site constraints.

TABLE 3. LEACH METHOD APPLICABILITY

Method	Site Constraints											Small Lot Size
	Soil Permeability			Depth to Bedrock			Depth to Water Table		Slope			
	Very Rapid	Rapid - Moderate	Slow - Very Slow	Shallow and Porous	Shallow and Nonporous	Deep	Shallow	Deep	0-5%	5-15%	15%	
Trenches		X	X ⁽¹⁾			X		X	X	X	X	X ⁽²⁾
Beds		X				X		X	X	X	X	X
Mounds	X	X	X	X	X	X	X	X	X	X	X	X

"X" means system can function effectively with that constraint.

Notes:

1. Construct only during dry conditions. Use trench configuration only.
2. Flow reduction suggested.



**GENERAL PROJECT SPECIFICATION FOR
SEPTIC TANK AND EFFLUENT DISPOSAL INTO DRAINAGE FIELD**

4.4 Trenches and Beds

- 4.4.1 Trenches shall be 300 mm to 900 mm (1 ft. to 3 ft.) wide and up to 30 m (100 ft.) or more long. Only one distribution pipe shall be installed per trench at the designed slope with the primary infiltration surfaces on the bottom and side walls of the excavation. The distribution pipe shall be laid with a minimum 150 mm (6 in.) thick bed of washed, graded, crushed rock or gravel, 20 mm to 50 mm (3/4 in. to 2 in.) in size. This material shall be placed in the trench bottom and levelled true to grade prior to laying the pipe. Aggregate shall be placed around the pipe until only the top center is still visible.
- 4.4.2 A final check of grade and alignment shall be made to confirm that the designed slope has been met. Then additional aggregate shall be placed in the trench so that the lines are covered with a minimum depth of 50 mm (2 in.) above the pipe. The trench shall be backfilled further to grade level with suitable material.
- 4.4.3 The sizing of trenches and beds is a function of the characteristics of the infiltrative surface. Table 4 shows several soil types, soil percolation rates and trench and bed loading rates. However, design rates shall be based on percolation test results.

ESSO EXPLORATION & PRODUCTION CHAD INC.



**GENERAL PROJECT SPECIFICATION FOR
SEPTIC TANK AND EFFLUENT DISPOSAL INTO DRAINAGE FIELD**

TABLE 4. TRENCH AND BED DESIGN CRITERIA

Soil Type	Percolation Rate (minutes/cm)	Trench Bed Bottom Area Application Rate ⁽¹⁾⁽²⁾ (cm/day)	Additional Criteria
Gravel, coarse sand	0.4	Not suitable ⁽³⁾	Trenches shall not be used in highly permeable soils.
Coarse to medium sand	0.4-2	5	
Fine sand, loamy sand	2-6	3	
Sandy loam, loam	6-12	2.5	
Loam, porous silt loam	12-14	2	
Silty clay loam, clay loam ⁽⁴⁾	24-48	1 ⁽⁵⁾	Use of trenches shall be limited to exceptional circumstances if percolation rates are lower than 24 min/cm. Trenches shall never be used where percolation rate is less than 48 min/cm.

Notes:

1. May be suitable estimates for sidewall infiltration rates.
2. Rates based on septic tank effluent from a domestic waste source. A factor of safety may be desirable for wastes of significantly different character.
3. Soils with percolation rates < 0.25 min/cm (1 min./in.) can be used if the soil is replaced with a suitably thick (> 600 mm (2 ft.) layer of loamy sand or sand.
4. Soils without expandable clays.
5. These soils may be easily damaged during construction.



**GENERAL PROJECT SPECIFICATION FOR
SEPTIC TANK AND EFFLUENT DISPOSAL INTO DRAINAGE FIELD**

4.4.4 As a design guide, Table 5 shows the suggested dimensions of trenches.

TABLE 5. TRENCH DIMENSIONS

Width (mm)	Length (m)	Depth Below Grade (mm)	Cover Thickness (mm)	Spacing Between Trenches (m)
300 to 900	30	450 to 600 ⁽¹⁾	150 min.	1.8 minimum ⁽²⁾

Notes:

1. May be deeper if more suitable horizon exists and groundwater table is low.
2. Measured from side wall to side wall; depends on design and on percolation characteristics of the soil.

4.5 Disposal Mounds

4.5.1 Mounds shall be used in relatively impermeable soils or in areas with shallow water tables or porous bedrock. Disposal mounds shall consist of trenches or beds constructed of suitable fill material placed above the existing grade. Effluent from septic tanks shall be siphoned or pumped into the mounds (usually medium to coarse sand) through distribution networks.

4.5.2 Mounds shall extend beyond the field a minimum of 3 m (10 ft) and enough to prevent seepage out of the sidesand.

5.0 DISTRIBUTION NETWORK

To achieve uniform application of effluent over the entire infiltrative surface area depending upon suitability and terrain, either of the two methods described herein shall be adopted.

5.1 Distribution Box Network (Figure 1)

5.1.1 The system shall use either of two different types of pipes:

- a. 100 mm (4 in.) diameter PVC pipes having two rows of holes near the invert 450 mm (18 in.) off vertical center. The holes shall be 10 mm to 20 mm (1/2 in. to 3/4 in.) in



**GENERAL PROJECT SPECIFICATION FOR
SEPTIC TANK AND EFFLUENT DISPOSAL INTO DRAINAGE FIELD**

diameter and spaced 75 mm (3 in.) apart. PVC solid pipes 100 mm (4 in.) in diameter shall be used from the distribution box to the perforated pipes.

- b. 100 mm (4 in.) diameter PVC drain tiles with 6 mm to 12 mm (1/4 in. to 1/2 in.) joint openings.

5.1.2 The basic system design shall be as follows:

- a. The perforated pipes shall be laid approximately level and the solid pipes shall be sloped depending upon the terrain.
- b. Effluent flows by gravity from the distribution box through the solid pipes to the perforated pipes or drain tiles.
- c. The number of pipes used and the distance between them is a function of the characteristics of the soil, percolation rate and the bottom area application rate.
- d. The 100 mm (4 in.) PVC perforated pipes or drain tiles, shall be interconnected by a solid common header of 100 mm (4 in.) PVC pipe and distribution box.
- e. Outlet inverts from the distribution box shall all be at the same elevation and the inlet invert shall be 25 mm (in.) above the outlet inverts.

5.2 Serial Distribution Method/Relief Line Distribution Network (Figure 2)

5.2.1 This system uses overflow or relief lines between trenches in place of distribution boxes. Similar to the distribution box network in paragraphs 5.1.1 and 5.1.2, this method also uses a combination of solid 100 mm (4 in.) PVC pipe and perforated 100 mm (4 in.) PVC pipe or open jointed drain tiles.

5.2.2 The basic system design shall be as follows:

- a. The invert of the overflow section shall be located near the top of the porous media in order to use the maximum capacity of the trench.



**GENERAL PROJECT SPECIFICATION FOR
SEPTIC TANK AND EFFLUENT DISPOSAL INTO DRAINAGE FIELD**

- b. For the gravity system, the invert of the overflow from the first absorption trench shall be at least 100 mm (4 in.) lower than the invert of the septic tank outlet.
- c. Relief lines shall be separated far enough apart to prevent short circuiting (1.8 m to 3 m (6 ft. to 10 ft.)).
- d. Pipe fittings for relief lines shall be selected to suit the slope.
- e. A minimum of 1.8 m (6 ft.) (horizontal) of undisturbed earth is recommended between absorption trenches.
- f. Distribution pipe in absorption trenches shall extend an equal distance (approximately) in both directions from the solid interconnection and relief pipes. Distribution pipes and trenches shall be level and normally follow slope contours.

6.0 PERFORMANCE TESTS FOR SEPTIC TANKS

- 6.1 Hydrotesting shall be used to demonstrate the strength of the tank to resist anticipated external and internal loads.
- 6.2 Testing for leaks to determine leakage below the ground water level shall be performed using or water pressure testing. Water pressure testing shall be performed by sealing the tank, filling with water and let stand for 24 hours; refill the tank; the tank shall be approved if water level is held for one hour.

7.0 MATERIALS FOR CONSTRUCTION OF SEPTIC TANK AND LEACH FIELD PIPING

7.1 Septic Tanks

7.1.1 Septic tanks shall be one of the following:

- a. Precast or cast-in-place reinforced concrete, watertight, structurally sound and resistant to excessive corrosion and decay. Inlet and outlet pipes shall be sealed with a compound that bonds both the concrete and pipe materials.



**GENERAL PROJECT SPECIFICATION FOR
SEPTIC TANK AND EFFLUENT DISPOSAL INTO DRAINAGE FIELD**

- b. Steel, epoxy or bitumen coated.
- c. Fibreglass; floatation collars may be required if the groundwater table is high.

7.2 Piping Materials for Leach Field

- 7.2.1 Pipes shall be perforated and solid PVC, 100 mm (4 in.) in diameter, (including fittings) in accordance with ASTM D 2729.
- 7.2.2 As an alternate to perforated pipes, 100 mm (4 in.) diameter PVC drain tile with 6 mm to 12 mm (1/4 in. to 1/2 in.) joint openings may be used.

8.0 CURTAIN DRAINS

If required, curtain drains shall be installed to prevent natural (ground) water seepage into a leach field. The drains shall be installed in accordance with ASTM D 2321 or F 449 and be at least 300 mm (1 ft.) deeper than the leach lines, and 2.4 m to 3.0 m (8 ft. to 10 ft.) from the leach line. The curtain drain shall be directed to a free outlet.

9.0 CLOSURE OF SEPTIC TANK AND DRAINAGE FIELD SITE

Before closure of a septic tank and drainage field site can be considered complete, the following items shall be completed:

- The septic tank shall be pumped empty. The sludge shall be disposed in a location and manner acceptable to ESSO.
- The septic tank shall be removed from the ground, repaired if necessary and reused. The hole shall be replaced with suitable fill. The topsoil and vegetation shall be replaced and suitable soil erosion mitigation measures shall be employed.
- The ends of all underground pipes shall be properly plugged.

ESSO EXPLORATION & PRODUCTION CHAD INC.



GENERAL PROJECT SPECIFICATION FOR
SEPTIC TANK AND EFFLUENT DISPOSAL INTO DRAINAGE FIELD

FIGURE 1 - DISTRIBUTION BOX LEACH FIELD
FOR LEVEL/GENTLE SLOPING SITES

ESSO EXPLORATION & PRODUCTION CHAD INC.



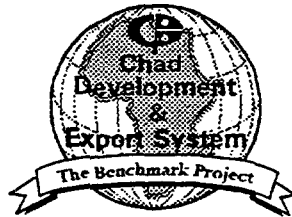
GENERAL PROJECT SPECIFICATION FOR
SEPTIC TANK AND EFFLUENT DISPOSAL INTO DRAINAGE FIELD

FIGURE 2 - SERIAL DISTRIBUTION LEACH FIELD FOR SLOPING SITES

ESSO EXPLORATION & PRODUCTION CHAD INC.



CHAD DEVELOPMENT PROJECT



GENERAL PROJECT SPECIFICATION FOR SURVEY CAMPS AND FACILITIES

GPS-020

Rev. No.	Date	No. of Pages	Prepared By	Reviewed By	Approved By	Revision Details
A		8				Issued for Comments
B		10	MEF	MEF	DJS	Issued for Proposals
0	30 Oct 97	10	MEF		DJS	Issued for EMP

1.0 INTRODUCTION 3

1.1 CAMP ADMINISTRATORS 3

1.2 DRUG AND ALCOHOL POLICY 3

1.3 TYPICAL PROBLEMS/ISSUES 3

1.4 SMOKING 3

1.5 PERMITS 4

2.0 CAMPS & FACILITIES 4

2.1 SCOPE 4

2.2 FIELD CAMPS 4

2.3 WASTE MANAGEMENT 9

2.4 RELIGIOUS CUSTOMS 9

2.5 DEMOBILIZATION 10

TABLE OF CONTENTS

<p>ESSO EXPLORATION & PRODUCTION CHAD INC.</p>  <p>GENERAL PROJECT SPECIFICATION FOR SURVEY CAMPS AND FACILITIES</p>



**GENERAL PROJECT SPECIFICATION FOR
SURVEY CAMPS AND FACILITIES**

1.0 INTRODUCTION

Contractor's camp(s) for the field work shall be a movable temporary facility appropriate for its size and duration. Contractor's camp shall provide life support for essential Esso, Contractor and Government personnel and visitors and shall comply with all governing statutes and/or regulations and living standards of Chad and Cameroon. Contractor shall store its permanent and consumable materials, supplies, and equipment within designated areas in or near the Camp—unless Contractor proposes a viable alternative, acceptable to Esso, or is instructed by Esso to locate this area in another location.

1.1 Camp Administrators

Contractor shall employ a Camp Administrator with sufficient experience and authority to solve, in an expeditious manner, any problems or allegations which may arise with regard to the services, whether administrative or operational, covered in any of the specifications. Each individual camp shall have a designated individual as the on-site Camp Administrator.

1.2 Drug and Alcohol Policy

The possession and/or consumption of alcoholic beverages is strictly prohibited. Possession and/or consumption may constitute grounds for dismissal. Drug and alcohol policy statements and implementation plans are provided in the Principal Document.

1.3 Typical Problems/Issues

Contractor shall consider and be aware of typical problems and issues including, but not limited to, handling of domestic or oily water and solid wastes, safe utilization and storage of pesticides, and ongoing monitoring of the quality of drinking and waste water. In addition, awareness of cultural differences, and the project policy prohibiting hunting and fishing in the project area are mandatory.

1.4 Smoking

Designated areas will be available for smoking. There will be no smoking in any of the living quarters or kitchen.



**GENERAL PROJECT SPECIFICATION FOR
SURVEY CAMPS AND FACILITIES**

1.5 Permits

Contractor(s) shall provide all requested details and requirements in support of its permit applications for Work Sites or other facilities. Contractor shall provide written notification to Esso for any deviation to originally submitted requirements so that adjustment can be made to current application.

2.0 CAMPS & FACILITIES

2.1 Scope

This specification applies to design and provision of camp(s) to be utilized during execution of the Work.

2.2 Field Camps

Contractor shall furnish all camps, supplies, and living quarters, and provide all support necessary, including access roads/service, for Contractor personnel, suppliers, Esso personnel and visitors, and government personnel as per Job Specifications. Camps shall be properly located taking into account safety, health, environmental, security, drainage, and other appropriate factors. Provisions need to be made for adequate rain-water drainage.

Contractor shall supply the following facilities and services, as a minimum, at each of its camps:

- Accommodations, including but not limited to living quarters, kitchen and dining area, shall be constructed of non-asbestos containing materials in such a manner as to provide protection against wind, rain and extreme temperatures, and shall be adequately screened against insects. When tents are used, a floor covering capable of being readily cleaned shall be provided. A minimum sleeping space of 4 square meters per employee is recommended where practical. All windows will have mosquito/insect netting or screens. All entrances will have double netting or a combination of a screened door and netting.



**GENERAL PROJECT SPECIFICATION FOR
SURVEY CAMPS AND FACILITIES**

- A separate covered, screened eating area with an easily cleanable floor covering shall be provided. Smoking in the messing area is to be restricted to a designated smoking section during meal times.
- Nourishing food per Survey Catering Services Specification GPS-021 for residing camp personnel.
- Bag-lunch for all personnel working outside of camp facilities.
- Laundry services, per Survey Catering Services Specification GPS-021, for residing camp personnel.
- Maintenance and janitorial service, per Survey Catering Services Specification GPS-021.
- Waste Disposal according to the approved waste management plan (as per Coordination Procedure Section 30 - Environmental Management).
- Bed linens, towels and bath soap shall be changed at least twice weekly, or as conditions warrant. Each living quarter shall be serviced daily, this to include as a minimum: making of bed, disposing of trash, general dusting, disinfection, broom-clean/vacuum/mop of floor.
- All living quarters should be made as insect-proof as possible by sealing the gaps between units and any spaces between ventilation equipment and the quarters. All window screens of mesh size appropriate for the insects of the area should be in place and checked for tears. In addition to living quarters doors or tent entrance netting, strips 4 cm wide, impregnated with insecticide (permethrin), should be hung in doorways to help with mosquito/fly control in buildings. Permethrin is available from Graniteville Co., Graniteville, SC (803) 663-5261, and other sources.

2.2.1 Ventilation

Fan(s) or Heating, Ventilation and Air Conditioning (HVAC) shall be provided to enhance circulation. Windows, vents, and doors shall be protected by screen mesh.



**GENERAL PROJECT SPECIFICATION FOR
SURVEY CAMPS AND FACILITIES**

2.2.2 Floors

Living quarters shall not have a natural ground surface.

2.2.3 Mosquito Netting

All sleeping areas will be equipped with individual mosquito netting. Bednets should be dipped and washed in a solution of cold water with 2.5% deltamethrin or permethrin to provide adequate protection. After washing, the bednets should be air dried before being returned to the sleeping areas.

2.2.4 Restrooms and Ablution Blocks

Contractor shall provide washrooms and other facilities, as necessary, to satisfy the religious needs and customs of its work force.

Washrooms shall be located and sized based upon the camp population and shall include adequate lighting and appropriate numbers of facilities. Separate facilities shall be provided for men and women.

In general, washrooms shall be constructed in well-ventilated areas, and supplied with an adequate amount of hot and cold water (potable), toilet paper and holders, waste receptacles, and deodorant.

2.2.5 Potable Water Supply

Contractor shall provide an adequate supply of potable water for all people at camp-sites and places of work. At least 25 gallons per person per day (95 liters per person per day) of potable water must be provided at camp-sites. The potable water storage and distribution system shall be adequately treated and acceptable evidence of potability shall be established and maintained. Water samples shall be sent in suitable containers to the Esso Senior Medical Representative for quality analysis as felt necessary by Esso. An adequate reserve of drinking water (at least one gallon per person) shall be maintained to assure water availability during any emergency conditions.



**GENERAL PROJECT SPECIFICATION FOR
SURVEY CAMPS AND FACILITIES**

Potable water may be bottled or generated using equipment to provide the level of treatment necessary to comply with the World Health Organization (WHO) Guidelines for Drinking Water Quality. The WHO potable water standards are listed in Table 2 of the Potable Water Treatment, Storage and Distribution (Temporary) Specification, GPS-003. Potable water must be free of all micro-organisms (including bacteria, viruses and parasites) and odor, colorless and have good taste.

Potable water shall be supplied to all camp facilities (showers, sinks, toilets, laundry, etc.). All camp taps shall deliver potable water. Alternatively, Contractor may use non-potable water in toilets, showers and laundry facilities provided the water has been produced using approved, Western standard industry practices and methods (including filtration for large particles, sediment and parasites), disinfection, and the water is odorless and colorless.

- Bottled drinking water will be provided where necessary for all expatriate personnel.
- Surface and ground water sources shall be properly located to minimize contamination and shall be a minimum of 300 feet from all fecal waste sources.
- All water supply systems will be properly constructed to minimize contamination and contact with domestic animals and wildlife.
- General use potable water tanks and distribution systems shall be chlorinated or bromated to at least 5 parts per million or 1.0 parts per million, respectively, at the time of storage.
- Potable water tanks and distribution systems shall not be subjected to contamination through cross connections to non-potable water supplies through back-flow or back-siphonage.
- Enough spare parts for on-site water treatment systems will be held in country to ensure minimal down time of the entire water treatment unit.



**GENERAL PROJECT SPECIFICATION FOR
SURVEY CAMPS AND FACILITIES**

- Potable water tanks and distribution systems shall be properly operated, maintained and calibrated. Residual levels of 0.5-1.5 and 0.2-1.0 parts per million of chlorine and bromine, respectively, shall be maintained at point of use.
- All wastewater and sewage shall be properly treated, stored and disposed of to minimize contamination of potable and non-potable water supplies.

2.2.6 Electrical Power

Camp power shall adequately supply all electrical requirements.

Contractor shall provide redundant (backup) sources of electrical power, staged at the base support location, equal to or greater than 30% of the total power generation capacity provided for the survey.

2.2.7 Fuel Storage

Storage of flammable liquids (diesel and gasoline) shall be in above-ground storage tanks located in properly lined and bunkered holding areas. Contaminated soil associated with vehicle fueling operations will be promptly collected and stored until it can be properly disposed. All flammable liquid storage areas shall be located a suitable distance from all manned facilities.

2.2.8 Kitchen

See Survey Catering Services Specification, GPS-021.

2.2.9 Dining Area

All windows and doors shall be protected by mesh screen and shall be kept in good condition. Doors shall be automatically closing (e.g., by coil spring or spring and hydraulic piston.) Dining areas, living quarters, and restrooms shall be located in close proximity to each other.



GENERAL PROJECT SPECIFICATION FOR
SURVEY CAMPS AND FACILITIES

2.2.10 Control of Insects and Rodents

Pest control is the Contractor's responsibility. Contractor shall utilize insecticides and pesticides approved by the Esso Medical Department.

Insecticides and pesticides shall be utilized in a controlled manner so as to avoid contamination of food and personnel. The Contractor shall emphasize insect and rodent control, making sure that garbage areas are clean. Contractor will take immediate action if a rodent situation should arise in the facilities.

2.3 Waste Management

All waste shall be handled and treated in accordance with Coordination Procedure Section 30 - Environmental Management.

2.3.1 Liquid Waste

If sanitary sewage shall be handled by a Wastewater Treating Plant, Contractor must comply with Package Sewage Treatment System (Temporary) Specification GPS-004. The unit(s) must be sized according to camp population such that effluent undergoes sufficient treatment to be suitable for discharge to surface waters (free of bacteriological and organic pollutants). Other on-site treatment systems must be approved by Esso in advance of use.

2.3.2 Solid Waste

Contractor's Waste Management Program shall provide a mechanism for disposal of all solid waste products avoiding social, economical, and ecological/environmental problems, and protecting aesthetics and health.

- Debris shall be separated and disposed of in proper manner, depending on the origin and condition. Recycling and reuse opportunities will be used where practical.

2.4 Religious Customs

Contractor shall provide prayer rooms and other facilities, as necessary, to satisfy the religious needs and customs of its work force.



GENERAL PROJECT SPECIFICATION FOR
SURVEY CAMPS AND FACILITIES

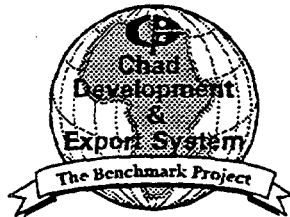
2.5 Demobilization

- 1) Contractor shall be responsible for restoration of areas utilized for camps and storage areas not needed by subsequent project contractors to their original state, in accordance with Section 30 of the Coordination Procedure - Environmental Management.
- 2) A final demobilization inspection will be completed by Esso and Contractor prior to site release.

ESSO EXPLORATION & PRODUCTION CHAD INC.



CHAD DEVELOPMENT PROJECT



GENERAL PROJECT SPECIFICATION FOR SURVEY CATERING SERVICES

GPS-021

Rev. No.	Date	No. of Pages	Prepared By	Reviewed By	Approved By	Revision Details
A		23				Issued for Comments
B	14 May 97	23	MEF	MEF	DJS	Issued for Proposals
0	30 Oct 97		MEF	<i>PAS</i>	DJS	Issued for EMP



GENERAL PROJECT SPECIFICATION FOR
SURVEY CATERING SERVICES

TABLE OF CONTENTS

1.0 PURPOSE.....4

1.1 Overview 4

1.2 Planning and Execution..... 4

1.3 Drug and Alcohol Policy 4

1.4 Overall Scope of the Services 5

 1.4.1 Meal Service 5

 1.4.2 Sanitation of Facilities and Garbage Collection, Segregation and Disposal 5

 1.4.3 Lodging, Laundry and Ironing Service 5

1.5 Contractor Personnel Requirements 6

 1.5.1 Hiring and Periodic Medical Examinations 6

1.6 Training 7

1.7 Reporting..... 8

 1.7.1 Cleanup and Cafeterias 8

 1.7.2 Personnel Administration 8

1.8 Equipment, Spare Parts and General Goods to be Supplied by Contractor.. 8

 1.8.1 Equipment..... 8

 1.8.2 Vehicles 9

 1.8.3 Spare Parts..... 9

 1.8.4 Refrigeration Units 9

 1.8.5 Ventilation 9

 1.8.6 Exhaust Fans and Filtered Ventilation 9

 1.8.7 General Goods 9

 1.8.8 Maintenance 10

 1.8.9 Floor Surface 10

 1.8.10 Table Tops and Counter Tops 10



GENERAL PROJECT SPECIFICATION FOR
SURVEY CATERING SERVICES

2.0 SPECIFIC OBLIGATIONS FOR EACH SERVICE 10

- 2.1 Meal Service..... 10
 - 2.1.1 Special Diets..... 10
 - 2.1.2 Test Sampling of Food..... 11
 - 2.1.3 Food Transportation and Storage..... 11
 - 2.1.4 Schedule for Providing the Service..... 11
 - 2.1.5 Regulations and Specifications for Providing the Service..... 12
 - 2.1.6 Menus..... 16
 - 2.1.7 Noxious Food..... 16
 - 2.1.8 Product Substitution..... 16
 - 2.1.9 Quality Control..... 16
- 2.2 Services of Cleaning and Sanitation; Garbage Collection, Segregation and Storage; Housekeeping; Laundry and Cafeteria 17
 - 2.2.1 Overview..... 17
 - 2.2.2 Services to be Included..... 17
 - 2.2.3 Schedule of Catering Operations..... 18
 - 2.2.4 Scope of Requirements and Specifications for Performance of Services..... 18



**GENERAL PROJECT SPECIFICATION FOR
SURVEY CATERING SERVICES**

1.0 PURPOSE

Contractor will provide Esso and Contractor employees and visitors with meal, laundry, housekeeping and cleaning services at camps as per Section 1 (General Execution Requirements), 23 (Occupational Health, Medical Facilities and Sanitation) and 29 (Socioeconomic Interactions) of the Coordination Procedure.

1.1 Overview

The services will entail materials, food, supplies, labor, supervision and all that is needed to perform these services, including: meal preparation, housekeeping, garbage/waste collection, segregation, storage and incineration. In addition, Contractor shall be responsible for cleanliness and sanitation of all impacted areas associated with the camp(s), and related services performed at other locations. All services will be performed according to requirements of the Job Specification.

1.2 Planning and Execution

Contractor shall employ all the resources and personnel required for planning, scheduling and estimating materials, equipment and goods, including all supplies, foodstuffs, cleaning elements and other equipment needed for the efficient, safe and hygienic performance of the services. Contractor shall have plans prepared, prior to mobilization, for Esso approval, that provides for foodstuffs, meals and the maintenance of all equipment required in the operation. Contractor must also present at the same time, to Esso, its updated procedure manuals for each of the activities.

Likewise, Contractor must have personnel to properly manage the purchasing, transportation, receipt and storage of all foodstuffs, materials, equipment, and goods required to provide a proper service.

1.3 Drug and Alcohol Policy

The possession and/or consumption of alcoholic beverages is strictly prohibited. Possession and/or consumption may constitute grounds for dismissal. Drug and alcohol policy statement and implementation plan are provided in the Principal Document.



**GENERAL PROJECT SPECIFICATION FOR
SURVEY CATERING SERVICES**

1.4 Overall Scope of the Services

Contractor will provide the following services:

1.4.1 Meal Service

Contractor will provide, at no cost to employees, meal services in Contractor operated and managed cafeterias, at all camps. This will include purchasing, preparing, serving and cleaning up. Proper attention shall be given to the hygienic storage, preparation and serving of food. Coverings for food preparation areas shall be provided as appropriate.

1.4.2 Sanitation of Facilities and Garbage Collection, Segregation and Disposal

Contractor will perform all cleaning services, as well as those of garbage collection, segregation, incineration, transportation, and disposal, at all facilities under its charge. Said activities shall be performed according to procedures agreed to by Contractor and Esso prior to mobilization.

1.4.3 Lodging, Laundry and Ironing Service

Contractor shall assign lodging and shall limit access to only authorized personnel. Project personnel shall be supplied with a clean supply of linens and cleaning implements for personal use. These items shall include but not be limited to: a set of bedding for single bed (bottom sheet, top sheet and pillow case), quilt, blanket, hand and body towels, floor mat, mattress cover, unscented soap, potable water and disposable cups.

Laundry and shower areas which can provide resting sites for adult mosquitoes should be sprayed every 3 days with chemical grade CHEM REZ-25 or deltamethrin using hand-held sprayers. Spraymen should wear goggles, nitrile-gloves, and a respirator during mixing and application.

All laundry will be machine washed and machine dried. Outer clothing of workers should be treated with deltamethrin or permethrin by the laundry personnel. Dipping and machine washing clothes in a solution of cold water with 2.5% deltamethrin or permethrin should provide adequate protection against mosquitoes. After washing, the clothes should be machine dried before being returned to the



**GENERAL PROJECT SPECIFICATION FOR
SURVEY CATERING SERVICES**

workers. Deltamethrin or permethrin will not fade or stain clothing, and it will not leave a noticeable odor. It remains protective through up to 40 washings with hot water and soap.

Bednets should be treated with deltamethrin or permethrin as described above for clothing. They should be kept closed around beds at all times, even when no one is sleeping in the bed. Bednets should be treated with deltamethrin or permethrin every 3 months.

Machine washing, machine drying, and ironing of all clothing and bedding related to provision of medical services must be done separately from the laundry of the camp residents.

Biodegradable soaps and detergents are mandatory. All laundry will be treated with permethrin or deltamethrin insecticide. Laundry bags will be kept in each of the rooms for persons staying overnight at the camps, in order to provide them with the laundry service.

All clothing and bedding will be ironed with a hot iron prior to returning to camp personnel.

1.5 Contractor Personnel Requirements

Contractor shall employ a Catering Administrator with sufficient experience and authority to solve, in an expeditious manner, any problems or claims which may arise with regard to the services, whether administrative or operational, covered in the specifications.

1.5.1 Hiring and Periodic Medical Examinations

Hiring medical examinations must be performed on all food handlers according to the legal requirements and the Job Specifications. Emphasis shall be placed on contagious diseases, dermatological and respiratory problems, gastric disorders and oral infections.

This information must be recorded in the personnel medical records, especially designed for this purpose.

Hiring Exams for Non-Food Handling Personnel:
(lodging, laundry and ironing service)

- General medical examination (stating the absence of infectious or contagious diseases and of skin ailments)
- Urinalysis



**GENERAL PROJECT SPECIFICATION FOR
SURVEY CATERING SERVICES**

- Complete blood count
- Thoracic X-ray and electrocardiogram as indicated

Hiring Exams for Food Handling Personnel:

- All of the above non-food handling personnel tests
- Microscopic exam of fresh stool for ova and parasites

Periodic Examinations:

- Exam periods shall be determined by the risks. At a minimum, exams must be carried out quarterly.
- Esso reserves the right to perform directly or through third parties, whatever medical examinations it considers necessary and to modify the requirements mentioned whenever it considers that it is necessary.
- A copy of each catering service employee's clinical history will be forwarded to Esso's Medical Department. Contractor will keep the originals which will be available for Esso's inspection. These are confidential documents and Contractor is responsible for handling them in a secure manner.
- Contractor, through their Camp Administrator in the field, is required to immediately report any illness or injury of food handlers to Esso's Medical Director and to report any corrective actions taken to verify the quality of the food supply.
- Esso reserves the right to request Contractor to withdraw from service any personnel who, in Esso's judgment, represents a health risk.

1.6 Training

If Contractor elects to utilize local/national labor in the execution of catering services he shall be responsible for training to include but not be limited to the following:

- Personal hygiene
- Facility sanitation and disinfection
- Housekeeping service regulations
- Food storage, preparation and service standards



**GENERAL PROJECT SPECIFICATION FOR
SURVEY CATERING SERVICES**

- Basic laundry practices
- Laundry practices for contaminated medical garments
- Garbage collection, segregation and disposal
- Proper procedures for control of insects and rodents
- Insecticide usage

1.7 Reporting

Contractor will submit reports, as per the formats established by Esso for such purposes, to the Esso site manager and Esso's Medical Director, for the following items:

1.7.1 Cleanup and Cafeterias

Scheduling of the cleanup brigades, particularly for disinfecting and pest control, to be carried out in the various facilities in Contractor's charge.

Weekly reports of inspections carried out on the facilities, along with a listing of any irregularities found and corrective action implemented.

1.7.2 Personnel Administration

Monthly reports on the following:

- Personnel housed and meals served
- Hiring and termination of personnel,
- Personnel training (indicating content and duration of course), and
- Occupational health activities.

1.8 Equipment, Spare Parts and General Goods to be Supplied by Contractor

1.8.1 Equipment

It is Contractor's responsibility to provide all equipment, spare parts and general goods required for the performance of the services.



**GENERAL PROJECT SPECIFICATION FOR
SURVEY CATERING SERVICES**

1.8.2 Vehicles

It is the Contractor's responsibility to provide vehicles for the transportation of Contractor personnel, materials and everything relating to the performance of these services.

The required vehicles must meet all industrial and project safety regulations defined in Coordination Procedure 22 - Project Safety Practices.

1.8.3 Spare Parts

Contractor will supply all the spare parts required to perform maintenance on its equipment.

1.8.4 Refrigeration Units

Contractor shall provide adequate freezers and refrigerators sufficient to properly provide safe cold storage.

1.8.5 Ventilation

Contractor shall provide adequate ventilation for both kitchens and food serving / dining areas.

1.8.6 Exhaust Fans and Filtered Ventilation

Contractor shall provide adequate exhaust fans and frequently cleaned filtered ventilation systems for both kitchen and dining areas. These must be of appropriate size to effectively provide ventilation.

1.8.7 General Goods

Contractor must supply, among other things: kitchen materials and implements (pots and pans, appliances, etc.), napkins, disposable cups, aluminum foil, plastic wrap, drinking water bottles, plastic garbage containers with lids, garbage bags and clear bags for food storage, waste paper baskets for restrooms, mops, brooms, polishers, buckets, deodorizers, detergents, disinfectants, toilet paper, plastic bags for sanitary napkin disposal, unscented soap with wrapper, liquid soap and dispensers, paper hand towels and dispensers for restrooms and paper towel rolls for food handlers and any other elements needed for the satisfactory performance of the



**GENERAL PROJECT SPECIFICATION FOR
SURVEY CATERING SERVICES**

catering services. Cloth towels are to be avoided in food preparation and food serving areas.

The following dining room general items, although not exclusively, shall be supplied for the required satisfactory levels of performance of the services: break-resistant tableware, flatware and trays; condiments; napkins; toothpicks; and linen. Sinks, brushes, soap and paper towels for hand washing must be provided in the immediate mess area.

1.8.8 Maintenance

It is Contractor's responsibility to perform a proper maintenance to guarantee the operability and long life of the equipment.

The use of garbage disposal units is prohibited in the kitchen.

1.8.9 Floor Surface

Kitchen and food preparation area floors must be non-porous to facilitate frequent disinfectant mopping.

1.8.10 Table Tops and Counter Tops

Contractor must surface all tables and counters in food service and food preparation areas with non-porous covering suitable for frequent disinfectant cleansing.

2.0 SPECIFIC OBLIGATIONS FOR EACH SERVICE

2.1 Meal Service

Meal services consist of providing balanced meals and nutrition of optimum organoleptic and microbiological quality.

Additionally, from time to time, Contractor will be responsible for preparing special function/ special menu meals upon request from Esso.

2.1.1 Special Diets

Contractor shall perform meal services, with a nutritionally balanced diet for any employees that have special diets, are under dietary medical attention, or are confined to beds for medical reasons.



**GENERAL PROJECT SPECIFICATION FOR
SURVEY CATERING SERVICES**

This service shall be prepared according to menus established by a certified nutritionist.

Esso's Representative will inform Contractor promptly of which non-Contractor persons are in the nutrition control program and update the listings, as needed, of the personnel requiring such services. Contractor will post adequate information on the bulletin boards regarding the "Special Menus." These menus will vary depending on the user's special requirements, such as, reducing cholesterol, reducing fat, etc.

2.1.2 Test Sampling of Food

Contractor will take samples of any food as requested by Esso administrative or medical personnel. Bacteriological tests may be performed periodically at the location during each phase of food preparation.

Receptacles and utensils for taking these samples will be supplied by Contractor at its expense. Contractor for each of the designated foodstuffs shall take a sample, which will be sealed hermetically and refrigerated for twenty-four (24) hours. Said samples will be made available for laboratory testing.

2.1.3 Food Transportation and Storage

Contractor must guarantee an adequate system of purchasing, transporting, preserving and handling of foodstuffs from supply point or source to the camps observing the minimum and maximum temperature and humidity conditions required for each type of food, so as to preserve these foodstuffs in optimum conditions of quality. All foodstuffs must be transported and stored observing reasonable health procedures.

2.1.4 Schedule for Providing the Service

The schedule for providing the service must be compatible with work requirements. Contractor is to provide one meal per employee for each meal setting, but is not required to provide more than three meals and two snacks per 24 hour period.



GENERAL PROJECT SPECIFICATION FOR
SURVEY CATERING SERVICES

2.1.5 Regulations and Specifications for Providing the Service

2.1.5.1 Meals

Contractor will provide, prepare and serve breakfast, lunch and dinner every day and to each person residing in the camp(s) and to guests authorized by Esso. This will include lunch for personnel in the camp and sack lunches for all other camp residents who work outside the camp area. The food served shall be top quality and in appropriate quantities. Coolers will be provided, if necessary, to ensure that sack lunches in the field do not spoil.

All food shall be prepared correctly and according to the menus accepted previously by the Esso representative and shall be served in a clean, hygienic, and attractive manner, by competent and efficient cooks and helpers.

Contractor must present to Esso, for approval, three (3) calendar days prior to the performance of the service, weekly menus of the normal and ethnic/religious (where applicable) types. Western style hot breakfasts and dinners will be served.

Contractor shall provide meals and pick up used dishes to disabled personnel abiding by special diets required for medical reasons.

2.1.5.2 Temperature

Food temperature at time of serving must be consistent with U.S. Public Health Service (USPHS) Requirements or other similar international standards agreed to by Esso's representative.

2.1.5.3 Spoiled Food or Food with Past Expiration Dates

Contractor may not utilize food with past expiration dates or food that is deteriorated or spoiled.

Esso reserves the right to inspect foodstuff warehouses and storage places for the purpose of verifying that the



**GENERAL PROJECT SPECIFICATION FOR
SURVEY CATERING SERVICES**

foodstuffs stored there do meet the minimum requirements mentioned above.

In the event that Esso officials find food with expired dates or deteriorated or spoiled food, they will proceed, together with Contractor, to destroy the products.

2.1.5.4 Meals According to Religious or Ethnic Custom

Contractor shall operate kitchens and meal service to meet the demands of a diversified multi-national work force.

To the extent practical, all food must be processed and prepared according to the various religious and cultural customs of all employees.

To the extent possible, Contractor will purchase foodstuffs nationally. Under no circumstances shall "bushmeat" or wild game be purchased for preparation in the camp kitchens and served in camp cafeterias.

2.1.5.5 Food Supplies

Contractor must keep a record of stock inventories, which must be available for periodic inspections by Esso.

The main warehouse will be the site assigned to store, classify and wash the foodstuffs, as required. The receptacles utilized for holding food must be washed hygienically before use.

Contractor must carry out disinfecting in the cold storage rooms at least once a week or whenever requested to do so by Esso.

2.1.5.6 Food Service Hygiene

Contractor must:

- Handle food according to the highest sanitary and hygienic standards developed by the USPHS or similar international standards agreed to by Esso's representative.



GENERAL PROJECT SPECIFICATION FOR
SURVEY CATERING SERVICES

- Enforce hygiene and cleanliness standards for all food services personnel, ensuring that they wash their hands before handling food. To this end, there must always be liquid soap, disposable towels, finger nail brushes, and disinfectant available for washing hands.
- Keep its personnel supplied with uniforms, shoes, caps and cook's hats, hair nets, face masks and gloves for handling food. In addition, the personnel must be supplied with the following protective gear: Gloves for food handling, protective gloves for cutting operations, plastic boots and aprons for washing and disinfecting the cafeterias.
- Ensure that personnel do not change clothes in the kitchen.
- Ensure that the personnel tending to the service line use white aprons, different from those utilized during the food preparation.
- Make the food handler's identification available to health authorities and Esso officials, as well as ensure that they are visibly worn during the performance of their duties.
- Make available the procedures manual for the cleaning and disinfecting of utensils, dinnerware, silverware, tables and hot tables, freezers, etc., to be utilized in the performance of the Contract. These procedures may be modified in agreement with Esso.

2.1.5.7 Tidiness and Cleanliness

Contractor must clean, tidy up and disinfect all facilities under its care and in so doing bear the responsibility of upholding the highest standards of cleanliness, neatness and hygiene. Esso will carry out periodic inspections at its facilities and will forward any pertinent observations, which shall immediately be addressed by Contractor.

Cleaning, disinfecting and tidying up will be done on tables, places where food is processed, chairs, grills and equipment in general, after every serving, utilizing biodegradable disinfectants and detergents.



**GENERAL PROJECT SPECIFICATION FOR
SURVEY CATERING SERVICES**

Kitchen equipment and utensils, including silverware, dinnerware and glasses will be washed with biodegradable detergents and disinfectants after each serving. The grease collector, the smoke exhaust funnels and the ventilators in the kitchen and cafeteria, will be cleaned at least once a week or more often, as needed.

The freezers, cold storage rooms and storage cupboards will be kept clean and disinfected according to the highest standards of cleanliness and free of residue and garbage. Special attention will be paid to pest and rodent prevention in the storage and bakery areas.

Contractor must clean the cafeteria tables and chairs before, during, and after each meal. The floors will be wet-mopped after each serving, washed during the day and scrubbed at least once a week. The windows must be cleaned at least once a month. Kitchen utensils and implements, dinnerware and silverware must be washed and sterilized after each serving. Refrigerators, foodstuff storage places, vegetable preparation rooms, etc., must be kept clean and waste free. Any screen-wire utilized on doors and windows must be kept in excellent repair.

The cleaning of outside areas will be the responsibility of the catering staff up to four (4) meters (13 ft.) from the facilities (cafeteria and storage warehouse) under their responsibility, which includes the washing of the outside of the facilities.

Contractor must make a diligent effort to keep the cafeteria and kitchen areas free of flies, mosquitoes and other insects, rodents and other pests.

All public restrooms must be cleaned at least two (2) times per day. Restrooms must be kept supplied with protective paper toilet seat covers, toilet paper, paper towels, liquid soap and dispensers. Biodegradable detergents must be used, to uphold the highest degrees of hygiene and environmental protection.



**GENERAL PROJECT SPECIFICATION FOR
SURVEY CATERING SERVICES**

The floors, baskets and trash and garbage receptacles must be washed and disinfected daily. They must be covered when not in use and kept at a distance from the food handling and processing areas.

Contractor must collect all wastes left at the tables, on dirty plates and utensils, and on trays and other implements utilized for serving the meals. Waste and garbage must be collected in bags/containers for such purpose and containers shall be kept covered, labeled and apart from the living area. Waste will be managed in a manner that prevents attraction of predators and scavengers as per Contractor's approved waste management plan.

2.1.6 Menus

Contractor shall offer the complete basic and special menus for breakfast, lunch and dinner, balanced and culturally/religiously appropriate, incorporating any recommendations made by the nutritionist.

The lunch and dinner menus must be different.

2.1.7 Noxious Food

Esso reserves the right to determine which ingredients in the preparation of the meals are harmful to health and to prohibit the use of said products.

2.1.8 Product Substitution

Product(s) may not be substituted into project foodstuffs or supplies without Esso approval.

2.1.9 Quality Control

Contractor must create and implement a Quality Control system for all products associated with camp food supplies, meal preparation and sanitation; in particular, perishable goods or those classified as having a high epidemiological risk. Said system must control, at least, the following:

- The fixing of organoleptic or physical-chemical parameters for fruits, meats, eggs and milk products. This will include washing



**GENERAL PROJECT SPECIFICATION FOR
SURVEY CATERING SERVICES**

fruits, vegetables, etc. in potassium permanganate, or chlorine solutions to kill disease causing organisms.

- Controls for perishable foodstuffs to include an ongoing verification of the packaging of said products and the conditions of transportation.
- Inspection of the system, handling and quality of frozen meats and fish.
- A manual that serves as a guide for receiving foodstuffs.
- Periodic visits to the various suppliers of perishable foodstuffs.

There will be at least one Contractor Supervisor present in the cafeteria during meals, who will be responsible for the promptness and efficiency of the service.

Contractor will guarantee an adequate stock of all classes of foodstuffs, as well as the supply and turnover of the same.

Requirements for the serving, as well as for the provision of food, must be based on the principle of providing fresh and appetizing meals, served in an agreeable ambiance, following reasonable hygienic and sanitary requirements.

2.2 Services of Cleaning and Sanitation; Garbage Collection, Segregation and Storage; Housekeeping; Laundry and Cafeteria

2.2.1 Overview

The services described below include, but are not be limited to: all materials, articles, food products, supplies, labor, and supervision necessary to provide the services of cleaning, sanitation and hygiene, garbage collection and recycling, at the sites mentioned in Section 1.1 as well as room, laundry and cafeteria services.

2.2.2 Services to be Included

Mobilization and housing of personnel and products necessary for performing the services of cleanup, garbage collection, segregation, incineration and disposal, as well as laundry, housekeeping and cafeteria services.



**GENERAL PROJECT SPECIFICATION FOR
SURVEY CATERING SERVICES**

Provision of necessary products/elements to carry out the services described in this specification.

Provision of the necessary personnel for collection, segregation, incineration and disposal of garbage and refuse that are produced in the kitchen and sanitation works within the camp and worksite facilities.

Operate the laundry and ironing equipment.

2.2.3 Schedule of Catering Operations

2.2.3.1 Sanitation and Cleaning Service

This service shall be performed seven (7) days a week with schedules which adjust to the needs of survey operations and in accordance with the requirements stipulated below.

2.2.3.2 Cafeteria Service

This service shall be performed seven (7) days a week according to schedules which adjust to the needs of survey operations.

2.2.3.3 Laundry Schedule

This service shall be performed seven (7) days a week according to schedules which adjust to the needs of survey operations.

2.2.3.4 Garbage Collection, Segregation and Disposal Service

This service shall be performed seven (7) days a week according to schedules that adapt to survey needs.

2.2.4 Scope of Requirements and Specifications for Performance of Services

2.2.4.1 Requirements for the Cleaning and Sanitation Service

All places listed in Section 1.1 must be swept, mopped, dusted daily and will be washed one time per week or more frequently, if so required. Debris will be removed as necessary.



**GENERAL PROJECT SPECIFICATION FOR
SURVEY CATERING SERVICES**

The Contractor, at its expense, shall periodically schedule, in conjunction with Esso, Sanitation Brigades to execute the following chores in a thorough manner:

- washing of the walls, windows, ceilings and doors
- fumigation* against insects and rodents in the facilities and up to a 4 meter distance around the same

* All pesticides must be approved by Esso prior to purchase, storage or use.

Cleaning will include the application of insecticides and disinfectants approved by Esso. It is mandatory to utilize household-type insecticides and baits, excluding pest and rodent control services in outside areas and general fumigation in the entire plant.

2.2.4.2 Overall Requirements

Contractor must fulfill the following general requirements, as a minimum, for the performance of the sanitation and cleanup services being considered in this section. It is also its responsibility to carry out periodic inspections in order to guarantee compliance with said standards:

DUTIES PERFORMANCE STANDARD

Refrigerators Must be kept clean and free of frost.

Water
Fountains Water fountains must be kept clean and disinfected.

Obstacles must be removed and leaks repaired immediately.

Sweeping A well-swept floor should not show signs or dust pan tracks. Dirt should not be left in the corners, behind the doors or under the carpets or furniture. Cleaning equipment and implements must be put back in their place. Rooms must be left in an orderly fashion.



GENERAL PROJECT SPECIFICATION FOR
SURVEY CATERING SERVICES

DUTIES	PERFORMANCE STANDARD
Mopping	Floors must be scrubbed with a damp cloth (not wet) and a mop with cleaning solutions (detergents, bactericides deodorizers or similar products).
Wall Washing	<p>There must be no visible streaks nor markings. Wood panels, as well as corners and other hard-to-reach areas must be clean. Walls and doors must be without hand prints and stains, washed using a soft cloth, soap and water and then dried.</p> <p>Walls must maintain their clear, uniform colors and must not be stained with the use of harsh cleaning solutions. Water must not be allowed to run onto the floors or electrical fixtures. Furniture must be put back in its place.</p>
Dusting	Dust must not be left on the surfaces. Grease stains and markings must not be left on the surfaces or walls by the use of oily cleaning agents. Dust must be removed, taking care not to spread it around offices and rooms.
Vacuuming	Personnel rooms and medical facilities must be vacuumed twice weekly.
Restrooms	Restroom areas must be scrubbed and disinfected twice daily. Toilets, basins and urinals must be kept clean inside and out. The use of detergents, cleaners and disinfectants must be to the highest degree. There are to be no marks left on the walls or other items, floors, dividers and partitions must be kept clean. Metal elements, doorknobs, etc., must be cleaned and polished. Mirrors must be kept clean and in their place.



GENERAL PROJECT SPECIFICATION FOR
SURVEY CATERING SERVICES

DUTIES	PERFORMANCE STANDARD
Towel Holders	Must be kept free of dust and dirt. Be careful with those materials that are not heat resistant or that cannot be mechanically washed.
Trash Removal	All areas where trash, waste, sand, etc., tend to gather, as well as access ways, passageways, flat areas, must be kept cleared.

Contractor must submit for Esso approval the Procedures Manual for the different sanitation and disinfecting activities, as well as for those regarding garbage and trash collection, segregation, incineration, and disposal that he expects to perform.

2.2.4.3 Washing and Ironing Service Requirements

Contractor shall be prepared to deal with the needs of a multi-national workforce. Laundry services will be operated for everyone staying at Contractor's camp.

Laundry facilities are to include procedures and provisions for permeation of clothing, barrier curtains, uniforms, mosquito nets, and other designated materials with Esso approved insect repellent solutions (generally Permethrin based).

Laundry facilities will be washed and cleaned so as to maintain a level of cleanliness that meets the requirements of the Job Specification.

Laundry procedures will include the following tasks: machine washing and machine drying; hot iron all washed items; sweep, mop, dust, and constantly remove accumulations of lint and fibers from the washers and dryers; maintain the laundry equipment free from detergent, soap and chemical residue used in the laundry process.



**GENERAL PROJECT SPECIFICATION FOR
SURVEY CATERING SERVICES**

Clothing from the medical center must be handled separately and the utmost care and control must be exercised in its disinfection. Chlorine bleach and hot wash cycles are to be used.

2.2.4.4 Housekeeping Service Requirements

Housekeeping service must include cleaning of the living quarters, sweeping and waxing, as appropriate, of floors, making of beds, complete cleaning of each bathroom, change of soap and a supply of toilet paper, as required, change of bed clothing at least two (2) times a week and as required and a daily change of towels, cleaning of glass fixtures, walls, closets, etc.

2.2.4.5 Requirements for Garbage Collection, Segregation and Disposal

Contractor will collect garbage and wastes daily or more often if necessary, at the following locations: kitchen, living areas, offices and workshops described in the terms of the CONTRACT, common areas and access ways. Garbage and wastes will be deposited in cans and containers until they are picked up, bearing in mind the following potential segregation categories:

- Paper
- Plastic
- Glass
- Non-Ferrous Metals
- Wood
- Ferrous Metals
- Food Products

Contractor is obligated to apply Esso's requirements concerning garbage, including collection, storage and disposal, as stated in Section 30 of the Coordination Procedure - Environmental Management.

2.2.4.6 Control of Insects and Rodents

Contractor shall emphasize insect and rodent control as a major priority, daily ascertaining that garbage areas are clean and free of rodent signs. Immediate action must be taken should a rodent situation arise in the camp. Control measures must be pre-approved by Esso personnel.



**GENERAL PROJECT SPECIFICATION FOR
SURVEY CATERING SERVICES**

Dirty or standing water and organic residues produced by the kitchen and food service areas will be disposed of on a daily basis. Holes and depressions that could trap standing water shall be filled with gravel as necessary.

2.2.4.7 Special Facilities Sanitation Service - Medical Service Area

Facility Sanitation and Disinfecting


Sanitation and disinfecting of these facilities will be defined by Esso's Health, Safety, Environmental (HSE) personnel, in coordination with Contractor's personnel. At a minimum, the medical service area must be mopped with disinfectant detergents two (2) times per day. Additional mopping will be carried out as requested and under the direction of medical personnel.

It is important that cleaning implements utilized in the medical service area not be utilized outside this facility.

Collection, Washing, Ironing and Delivery of Clothing

The procedure for medical service related laundry collection, washing, ironing and delivery is to be performed separately from other camp laundry (a separate washer, dryer and iron must be employed). HSE will define other recommendations on this particular process to Contractor.

Cleaning of facilities must be done at least two (2) times per day.

ESSO EXPLORATION & PRODUCTION CHAD INC. 	WASTE INCINERATOR	CCS 7-1-10 Page 1 of 12	
TECHNICAL SPECIFICATION		Rev. 0	04 Nov 96

CHAD DEVELOPMENT PROJECT

TECHNICAL SPECIFICATION

Rev. No.	Date	No. of Pages	Prepared By	Reviewed By	Approved By	Revision Details
0	4 Nov 96	12	FRE	PRS	MAS	IFP Issue



ESSO EXPLORATION & PRODUCTION CHAD INC. 	WASTE INCINERATOR	CCS 7-1-10 Page 2 of 12	
TECHNICAL SPECIFICATION		Rev. 0	04 Nov 96

TABLE OF CONTENTS

1.0 SCOPE	3
2.0 SUMMARY OF ADDITIONAL REQUIREMENTS	4
3.0 DOCUMENTATION	5
4.0 DESIGN/CONSTRUCTION FEATURES.....	5
5.0 MATERIALS	11
6.0 FABRICATION	11
7.0 INSPECTION AND TESTING	11
8.0 INSTALLATION.....	12
9.0 PERFORMANCE.....	12
10.0 OPERATIONS MANUALS.....	12


LIST OF TABLES

TABLE 1.....	3
TABLE 2.....	6

ESSO EXPLORATION & PRODUCTION CHAD INC. 	WASTE INCINERATOR	CCS 7-1-10 Page 3 of 12	
TECHNICAL SPECIFICATION		Rev. 0	04 Nov 96

1.0 SCOPE

- 1.1 This specification covers the general requirements for design, fabrication, inspection, testing, supply and installation of a waste incinerator system and its associated equipment to be used for on-site incineration of municipal and construction debris, and crude oil/solids.
- 1.2 The system will be located outdoors in an oil and gas production facility. The system shall be capable of safely incinerating construction debris, construction personnel waste including kitchen waste and bio-sludge, medical waste, municipal waste, and industrial waste.
- 1.3 The system shall provide (with proper maintenance) long term (30-years project life) reliable operation (incinerator may not run continuously).
- *1.4 The incinerator shall be designed to process a minimum of 5 million BTU/hr for 8 hours a day. Additional design capacity shall be determined by Contractor in order to ensure incineration capacity for its wastes as required by its waste management plan and to incinerate all combustible camp/office and industrial wastes during operation.
- 1.5 No chlorinated wastes will be feed to incinerator and waste feed mixture will have a minimum heat content of 6000 BTU/LB.
- 1.6 The incinerator should be designed to comply with US EPA regulations for municipal waste incineration (40CFR240), at a minimum, to insure long term quality of operation. Design shall also be appropriate for any solvents or hazardous wastes that may be incinerated as per Contractor's Waste Management Plan.
- 1.7 The system shall be a complete package of the Supplier's standard design suitable for the application as described in this specification. This package may include, but not necessarily be limited to, the following items:
 - primary and secondary combustion chambers
 - blowers, drivers, coupling, guards, ducts and equipment shelter
 - built-in stack
 - trays or containers for solids or sludge
 - refractory lining
 - fuel handling equipment capable of firing diesel fuel
 - automatic ash removal facilities

ESSO EXPLORATION & PRODUCTION CHAD INC. 	WASTE INCINERATOR	CCS 7-1-10 Page 4 of 12	
TECHNICAL SPECIFICATION		Rev. 0	04 Nov 96

- burner management controls system
- pollution control equipment, as required
- waste pre-processing (e.g., shredding) and loading system
- start-up and commissioning of the system

1.8 A pound sign (#) indicates that ESSO review/approval is required before design is finalized or equipment is purchased.

1.9 An asterisk (*) indicates that additional information is required. This additional information is provided in other project documents or will be furnished during the detailed engineering phase.


2.0 SUMMARY OF ADDITIONAL REQUIREMENTS

2.1 All codes, standards, regulations and specifications referred to in this specification shall form an integral part of this specification.

2.2 Table 1 lists the other CCS specifications, codes and standards which shall be used as a part of this specification:

TABLE I

SPECIFICATIONS	
CCS	
2-1-1	Equipment Noise Level Data Requirements
3-4-1	Piping for Fired Equipment
3-18-1	Piping Fabrication
3-19-1	Piping Erection Testing
4-1-2	Structural Steel Design, Fabrication and Erection
4-1-3	Design Loads for Structures
4-2-1	Auxiliary Structures for Operation & Maintenance
15-0-100	General Instrument Specification
15-2-1	Temperature Instruments
15-3-1	Pressure Instruments
15-6-2	Environmental Protection for Electronic Devices
15-6-3	Programmable Logic Controllers
15-11-1	Instrument Control Panels
16-9-1	AC Motors
20-1-1	Inspection of Equipment and Materials
20-1-3	Quality Programs and Quality Assurance Plans
21-20-108	Environmental Impact Mitigation
CODES AND STANDARDS	
ASME	
B31.3	Chemical Plant and Petroleum Refinery Piping
B16.5	Steel Pipe Flanges and Flanged Fittings
B16-47	Large Diameter Steel Flanges NPS 26 through NPS 60"
	Richard A. Connery and N.D. Ross Handbook of Industrial Waste Disposal, Van Nostrand and Reinhold 1980

ESSO EXPLORATION & PRODUCTION CHAD INC. 	SOLID WASTE LANDFILL	CCS 13-4-1 Page 3 of 27	
TECHNICAL SPECIFICATION		Rev. 0	11 Nov 96

1.0 SCOPE

- 1.1 This specification includes the technical requirements for the design, construction and operation of a landfill site to be used for both hazardous and non-hazardous solid waste disposal. The construction includes earthwork, access roads, and installation of a landfill with a composite liner and leachate collection system and monitoring wells. The operation includes maintaining each landfill cell, collecting leachate and monitoring leachate and monitor-well water quality during the Pre-Operation phase.
- 1.2 A pound sign (#) indicates that ESSO review/approval is required before design and/or construction is finalized or equipment is purchased.
- 1.3 An asterisk (*) indicates that additional information is required. This information is provided in other project documents or will be furnished during the detailed engineering phase.

2.0 SUMMARY OF ADDITIONAL REQUIREMENTS

- 2.1 The publications listed in Table 1 are incorporated by reference into this specification. Except as modified by the requirements specified herein, work covered by this specification shall conform to the applicable provisions of these publications.

TABLE 1

SPECIFICATIONS	
CCS	
4-10-1	Concrete Design and Construction
4-11-1	Chain Link Fencing
4-100-1	Roads and Area Paving
21-20-107	Soil Erosion Mitigation Specification
21-20-108	Environmental Impact Mitigation Specification
GPS	
008	Project Safety Requirements
011	Waste Management
CODES AND STANDARDS	
ASTM	
C136	Sieve or Screen Analysis of Fine & Coarse Aggregate
C478	Precast Reinforced Concrete Manhole Sections
D422	Test Method for Particle - Size Analysis of Soils.
D1140	Test Method for Amount of Material in Soils Finer Than the No. 200 (75- μ m.) Mesh
D1557	Laboratory Compaction Characteristics of Soil Using Modified Effort [56,000 ft-lb/ft ³ (2700 kN-m/m ³)]
D2216	Test Method for Laboratory Determination of Water (Moisture) Content of Soil and Rock
D3034	PSM Poly (Vinyl Chloride) PVC Sewer Pipe and Fittings (Perforated)
D4253	Maximum Index Density and Unit Weight of Soils Using a Vibratory Table
D4254	Minimum Index Density and Unit Weight of Soils and Calculation of Relative Density


ESSO EXPLORATION & PRODUCTION CHAD INC. 	SOLID WASTE LANDFILL	CCS 13-4-1 Page 4 of 27	
TECHNICAL SPECIFICATION		Rev. 0	11 Nov 96

TABLE 1 (CONT'D)

ASTM (cont'd)	
D4318	Test Method for Liquid Limit, Plastic Limit, and Plasticity Index of Soils
D5084	Test Method for Measurement of Hydraulic Conductivity of Saturated Porous Materials Using a Flexible Wall Permeameter
D5093	Standard Test Method for Field Measurement of Infiltration Rate Using a Double-Ring Infiltrometer with a Sealed-Inner Ring.
USCOE U.S. ARMY CORPS OF ENGINEERS	
EM 1110 2-1906	Corps of Engineers Manual
Standard Methods for the Examination of Water and Wastewater	
Mary Ann H. Franson, editor, American Public Health Association, 1995	

3.0 PURPOSE OF SOLID WASTE LANDFILL

3.1 The solid waste landfill shall be designed, constructed and operated to accept the following:

- *a. Solid wastes approved in the Contractor's Waste Management Plan in accordance with Section 30 of the Coordination Procedures and GPS-011:
- b. All domestic and industrial solid wastes from the operating facility during its operating life cycle.
- c. All potentially hazardous wastes such as batteries and incinerated medical wastes generated during operations and construction.

3.2 The design, construction and operating procedures of the solid waste landfill shall recognize the existence of an incinerator at the site during the operation phase.


3.3 All landfill cells used during the pre-operations phase shall be closed prior to turning care and custody of the facility over to ESSO.

4.0 SITE SELECTION

4.1 Initial Selection Criteria

The criteria for the selection of landfill sites shall be as follows:

- a. Avoid residential areas, wetland, critical wildlife habitats, drainage courses and areas subject to seasonal flooding.
- b. Sites shall not be chosen within the 100 year flood plain of a stream, river or lake.
- c. The landfill shall not be located within 500 m (1640 ft.) of an airfield. This restriction is imposed to reduce bird hazard.

ESSO EXPLORATION & PRODUCTION CHAD INC. 	WASTE INCINERATOR	CCS 7-1-10 Page 5 of 12	
TECHNICAL SPECIFICATION		Rev. 0	04 Nov 96

3.0 DOCUMENTATION

- 3.1 Supplier shall supply drawings and data in sufficient detail to define interface requirements, describe all systems including accessories, define operational requirements, necessary foundation and other related installation and support services needed for the waste incinerator system.


4.0 DESIGN/CONSTRUCTION FEATURES

4.1 The incinerator design must address the following:

- Unit must provide a safe and low maintenance feed system. Feed door system must provide adequate seals.
- System must provide excellent burn out of all organics. The destruction removal efficiency (DRE) for organics shall be >99% for a resulting ash organic content <1.0% carbon by wt.
- Minimum combustion temperature 815 °C (1500°F) in primary stage and 982 °C (1800°F) in secondary stage.
- Thermal NO_x <45 ppm
- Particulate loadings ≤ 0.10 grains/dSCF corrected to 12% CO₂
- Unit must have a minimum of two combustion stages.
- Flue Gas residence time ≥ 1.5 seconds.
- Unit will be operated 8 hours/day.
- % opacity ≤ 5.
- Input material density 2000 lbs/yd³.
- A shredder shall be provided to reduce all waste feed to 3 in. max. (widest dimension)

4.2 Incinerator will be provided with low fire system capable of maintaining a unit temperature of 105 °C (220°F) minimum.

4.3 The incinerator instrumentation must be kept to a minimum for long term maintainability and ease of operation. The unit will be designed for manual operation to the extent possible.

ESSO EXPLORATION & PRODUCTION CHAD INC. 	WASTE INCINERATOR	CCS 7-1-10 Page 6 of 12	
TECHNICAL SPECIFICATION		Rev. 0	04 Nov 96


4.4 Waste Classification

The classification of potential wastes to be incinerated shall be as per the following table.

TABLE 2

Waste Type	Description	Typical Analysis	Moisture wt. %	Density kg/m ³	Heat Content kJ/kg
0	Dry industrial & commercial rubbish	Cardboard, dry paper, wooden pallets, floor sweepings, plastic bags	10	5	8500
1	General industrial commercial & domestic rubbish	Cardboard, paper, floor sweepings, up to 20% kitchen waste	25	10	6500
2	Refuse	Kitchen & domestic wastes, wet paper, floor sweepings, garden waste	50	15	4300
3	Pathological materials	Hospital dressing, disposable bedding, gowns, etc.	10-30	5-15	4500-8000
4	Pathological remains	dead animals, human tissue, etc.	85	25-75	1000
5	Industrial wastes/oil sludge	Industrial process wastes	-	850-960	40,000
6	Semi-solid and solid wastes	Combustibles requiring hearth, retort, or grate burning equipment	-	Variable according to waste survey	Variable according to waste survey

Note: Waste classification based on Handbook of Industrial Waste Disposal, Tables 9-1 & 9-3.

ESSO EXPLORATION & PRODUCTION CHAD INC. 	WASTE INCINERATOR	CCS 7-1-10 Page 7 of 12	
TECHNICAL SPECIFICATION		Rev. 0	04 Nov 96

#4.5 Design Basis

The design basis, waste production rate, required incinerator capacity, operational features and fuels supplied shall be specified in a waste incinerator data sheet to be supplied to ESSO for approval. Capacity will be as indicated in 1.4. Contractor may use the incinerator during construction provided the system is fully refurbished, operational and does not show unreasonable wear when turned over to ESSO in accordance with paragraph 7.4.

4.6 Body Casing


- a. The incinerator assembly shall be made of carbon steel plate and adequately reinforced with structural steel members.
- b. The primary and secondary chambers shall be completely seal welded to prevent the inclusion of incoming air.

4.7 Access for Inspection and Maintenance

- a. Both primary and secondary chambers shall be provided with adequate access doors for waste loading, inspection, maintenance and ash removal.
- b. Each door assembly shall include a sealing device adequate to stand the internal temperature of the chambers and to prevent air from outside. Unit shall be designed to hold a minimum of 12.5 mm (0.5 inch) water negative pressure.
- c. Supplier shall provide adequate ladder(s) and platform(s) for easy access to perform inspection and maintenance.

4.8 Sight Glasses

- a. Both primary and secondary chambers shall have sight ports or sight glasses permitting safe observation of the combustion process throughout the operation.

ESSO EXPLORATION & PRODUCTION CHAD INC. 	WASTE INCINERATOR	CCS 7-1-10 Page 8 of 12	
TECHNICAL SPECIFICATION		Rev. 0	04 Nov 96

4.9 Refractories

All refractory design and material shall be suitable for this service.


- b. The calculated cold face temperature of the exterior surface of the casing shall not be more than 82 °C (180°F) based on a design maximum ambient temperature of 42 °C (108°F).
- c. The castable refractory shall be acid gas resistant and secured to the inside of the steel casing with anchors made of stainless steel.

4.10 Waste Loading and Ash Removal Facilities

Supplier shall propose a system with related facilities to ensure the operation can be carried out efficiently and safely with minimum involvement of the operators. Supplier shall provide design such that ash removal from the primary chamber will be initiated automatically at the end of the cool-down cycle.


4.11 Burner and Ignition System

- a. Supplier shall provide only designs that have been in service for at least 2 years.
- b. The primary and secondary burners shall be flange mounted on the incinerator casing and piped to a single fuel supply line for ease of installation.
- c. All burners shall be capable of firing diesel. Electric ignition system shall be provided.
- d. All burner combustion air shall be supplied by air blowers. These air blowers shall be mounted on the incinerator casing with ducting leading to the ports of the combustion chambers.
- e. Blowers and motors shall be provided with external lubrication. Lubrication facilities shall be grouped together for easy access for maintenance.
- f. Burners with high turndown ratio shall be used for the purpose of warming up combustion chambers, good modulation of control and fuel efficiency.

ESSO EXPLORATION & PRODUCTION CHAD INC. 	WASTE INCINERATOR	CCS 7-1-10 Page 9 of 12	
TECHNICAL SPECIFICATION		Rev. 0	04 Nov 96

4.12 Instrumentation and Controls

- a. Instrumentation shall follow the requirements outlined in CCS 15-1-200 for Small Oil Fired Heaters.
- b. Supplier shall provide a complete Burner Management Package (BMP) for fuels as outlined on data sheets. BMP shall monitor pilots, main burners, fans, fuel supplies, combustion chambers, stack, and all other required control parameters. BMP shall also shutdown the incinerator upon a system failure and/or detection of a hazardous condition.
- c. Temperature control shall be segmented per burner gallery. Temperature control of the stack shall be included, in the control scheme, as required to meet waste incineration requirements including medical, municipal and industrial wastes.
- d. Other control and monitoring parameters to be considered are:
 - flow rate of waste to be incinerated
 - proper/complete incineration
 - emission concentration and levels allowable of incinerated products including NO_x, CO, CO₂, O₂, SO₂, PM₁₀ and HCl.
- e. Control shall be stand-alone electronic (PLC) per CCS 15-6-3.
- f. Local panels shall be suitable for outdoor and tropical use and meet CCS 15-11-1.
- g. Supplier shall submit with its bid the restrictions of controls/control panel and if control room environment is required.
- h. Supplier shall supply the control system completely coordinated, constructed, wired, and checked out at factory.
- i. Supplier shall route/terminate locally mounted instruments through a skid edge junction box, to the control panel. Local control panel may have the junction box integral.
- j. Input and output signals shall be provided via a PLC Serial Communications Port for the following:
 1. Stack temperature
 2. Stack temperature set point
 3. Incinerator common alarm.


ESSO EXPLORATION & PRODUCTION CHAD INC. 	WASTE INCINERATOR	CCS 7-1-10 Page 10 of 12	
TECHNICAL SPECIFICATION		Rev. 0	04 Nov 96

4. Incinerator/component running status.
5. Incinerator shutdown.
6. Emergency Shut Down input.
7. Low fire state (control input).
8. Permissive to start (control input).
9. Local ESD
10. Any other available PLC register information.

- #k. Contractor's selected Supplier's standard package shall be accepted provided that it meets or exceeds ESSO standards.
- l. All instruments shall appear on a P&ID in compliance with Supplier ISA Standards, tag numbers shall be assigned by ESSO.
- m. All instruments shall have ISA type data sheets.
- #n. All control devices and systems shall be rated for IP66 and submitted to ESSO for approval.
- o. Instrument tagging shall follow these guidelines: in-line equipment and major components such as PLCs shall have a nameplate with the following information equipment identification number (instrument tag number), pressure rating of pressure containing parts, supplier's name, model, serial number, operating range, materials, size of outer and inner components, voltage appraisal class, type, and range as applicable.
- p. Information plates and name tags shall be securely attached by mechanical means with threaded fastener or fluted rivets. Adhesive fastening method is not acceptable. Only the instrument number tag may be fastened by stainless steel cable connected with stainless steel crush clamps, or 18 gauge stainless steel wire.
- q. PLC shall have a communications port using Allen Bradley Data Highway Plus for interfacing to the Pipeline Automation System.
- r. All transmitters shall be Honeywell Smart Transmitters.
- s. All electrical/electronic equipment and devices must be listed and labelled by a Cenelec recognized testing agency for their intended use.

4.13 Noise Requirements

The incinerator contribution to sound level shall be in accordance with CCS 2-1-1.

ESSO EXPLORATION & PRODUCTION CHAD INC. 	WASTE INCINERATOR	CCS 7-1-10 Page 11 of 12	
TECHNICAL SPECIFICATION		Rev. 0	04 Nov 96

4.14 Emission Requirements

- a. The air quality standards of CCS 21-20-108 shall be met.

4.15 Area Classification

Area classification for the location of the incineration system shall be specified in accordance with contract documents associated with this specification.

5.0 MATERIALS


- 5.1 Unless otherwise stated in this specification, the materials of construction shall be the Supplier's standards that are suitable for the process and environment and have been proven successful in similar services.
- 5.2 A certificate of material compliance is required where special alloys other than carbon steel are being used.

6.0 FABRICATION

- 6.1 The entire incineration system with its components shall be fabricated and packaged prior to shipment to the field site as much as possible to minimize field work.
- 6.2 Supplier shall fabricate and layout the whole system within the maximum dimensions permissible for transportation and be ready for start-up with minimal field assembly except to interface with the required site facilities.

7.0 INSPECTION AND TESTING

- #7.1 The inspection and quality control program shall be carried out and executed in accordance with CCS 20-1-1 and as approved by ESSO.
- 7.2 Contractor shall furnish ESSO with copies of all inspection and quality control documents in accordance with CCS 20-1-1 and CCS 20-1-3.
- 7.3 Instrument and control devices/systems shall be factory acceptance tested and approved prior to shipping.
- 7.4 Contractor shall refurbish, reinspect and acceptance test the incinerator as approved by ESSO if the incinerator is used during construction per paragraphs 4.5 and 9.2

ESSO EXPLORATION & PRODUCTION CHAD INC. 	WASTE INCINERATOR	CCS 7-1-10 Page 12 of 12	
TECHNICAL SPECIFICATION		Rev. 0	04 Nov 96

8.0 INSTALLATION


- #8.1 Once approved by ESSO, Contractor shall install the incinerator system described in Section 4, above, including any accessories, interfaces and other related support services required to start-up and operate the incinerator system.

9.0 PERFORMANCE

- 9.1 Contractor shall guarantee that the system meets the requirements stated in this specification. It shall be the responsibility to correct any deficiencies at a time agreeable to ESSO.
- 9.2 Contractor may operate the incinerator system as needed until construction activities have been completed. Contractor shall incinerate its domestic, industrial and construction wastes as specified in Contractor's approved Waste Management Plan, as well as any start-up wastes generated during this period as approved by ESSO. Waste incinerated prior to Facility Acceptance may be incinerated in a Temporary Incinerator (if Contractor elects to use as per GPS 006) or in the incinerator installed for ESSO (provided that the condition of the incinerator meets requirements of ESSO and paragraphs 4.5 and 7.4).

10.0 OPERATIONS MANUALS

- 10.1 Supplier shall provide ESSO with complete manuals for operation and maintenance of the incinerator system and related accessories, interfaces, and support services.

ESSO EXPLORATION & PRODUCTION CHAD INC. 	WATER WELLS	CCS 11-10-1 Page 1 of 10	
TECHNICAL SPECIFICATION		Rev. 0	04 Nov 96

CHAD DEVELOPMENT PROJECT

TECHNICAL SPECIFICATION

Rev. No.	Date	No. of Pages	Prepared By	Reviewed By	Approved By	Revision Details
0	7 Nov 96	10	EHW	PRP	MAS	IFP Issue



ESSO EXPLORATION & PRODUCTION CHAD INC. 	WATER WELLS	CCS 11-10-1 Page 2 of 10	
TECHNICAL SPECIFICATION		Rev. 0	04 Nov 96

TABLE OF CONTENTS

1.0	SCOPE.....	3
2.0	SUMMARY OF ADDITIONAL REQUIREMENTS	3
3.0	GROUND WATER SUPPLY AND WELLS	4
4.0	PUMP CONTROL	9
5.0	WELL PUMPS AND MOTORS.....	9

LIST OF TABLES

TABLE 1.....		3
--------------	--	---

ESSO EXPLORATION & PRODUCTION CHAD INC. 	WATER WELLS	CCS 11-10-1 Page 3 of 10	
TECHNICAL SPECIFICATION		Rev. 0	04 Nov 96

1.0 SCOPE


- 1.1 This Specification covers the requirements for the design of the potable/ utility water and fire water supply from ground water wells.
- 1.2 A pound sign (#) indicates that ESSO review/approval is required before design and/or construction is finalized or equipment is purchased.

2.0 SUMMARY OF ADDITIONAL REQUIREMENTS

- 2.1 Table 1 lists the standards, codes, and specifications which shall be used with this Specification.

TABLE 1

SPECIFICATIONS	
<u>CCS</u>	
3-2-3	Fire Water Systems
3-7-1	Piping Flexibility and Supports
3-12-1	Valve Selection Criteria
11-10-2	Potable Water Treatment, Storage and Distribution
15-0-100	General Instrument Specification
16-7-1	Motor Application
16-9-1	AC Motors
17-6-1	Fire Protection Systems for Buildings
19-1-10	Painting Above-ground Facilities
19-5-1	Cathodic Protection
CODES AND STANDARDS	
<u>API</u>	
5L	Line Pipe
<u>AWWA</u>	
A100	Wells
A200	Steel Pipe (Over 150m)
C508	Check Valves
C654	Disinfection of Wells
E101	Vertical Turbine Pumps - Line Shaft and Submersible Types
<u>ASTM</u>	
A53	Standard Specifications for Pipe, Steel, Black and Hot-Dipped, Zinc-Coated Welded and Seamless
C33	Concrete Aggregates

ESSO EXPLORATION & PRODUCTION CHAD INC. 	WATER WELLS	CCS 11-10-1 Page 4 of 10	
TECHNICAL SPECIFICATION		Rev. 0	04 Nov 96

3.0 GROUND WATER SUPPLY AND WELLS


3.1 The water supply source is to be developed from an aquifer from which the quality and quantity desired can be produced

- # a. A hydrogeologist, approved by ESSO, shall be retained to advise on well location, spacing, design and construction. The wells shall comply with AWWA A100.
- b. Wells shall be located to avoid sources of surface or subsurface pollution and/or flooding. The elevation of the top of the wells should be at least 600 mm (2 ft.) above the highest expected flood level.
- c. Number of wells, size and depth of borings, gravel packs, screen sizes, well casings, sizes, number and capacity of multistage submersible pumps and electric motors, and size of discharge piping and other necessary components shall be designed to meet the required discharge pressures and flows as per CCS 3-2-3 and CCS 11-10-2.
- d. Spacing of wells shall be such that the drawdown curves do not overlap for adjacent wells (including hand-dug wells and other watering holes used by the local population).
- e. The well design shall ensure that the screen section is always fully submerged and that any fluctuations in the elevation of the top of the saturated zone have been taken into account.
- f. A water supply well shall not be located within 500 m (1640 ft.) radius of any landfill.

Test Hole & Alignment

3.2 Contractor shall drill a test hole to a depth required to reach and penetrate water bearing strata and continue for 3 meters (or 10 ft.) into impervious stratum immediately below the lowermost sand layer.

- a. Perform Eastman inclination single shot survey or other acceptable survey on each 20 meter (or 65 ft.) increment of drilling. Test hole shall be vertical within one degree from true vertical and vary not more than 75 mm (or 3 in.) in any 20 meters (or 65 ft.).


ESSO EXPLORATION & PRODUCTION CHAD INC. 	WATER WELLS	CCS 11-10-1 Page 5 of 10	
TECHNICAL SPECIFICATION		Rev. 0	04 Nov 96

- # b. Obtain samples of each water bearing sand stratum penetrated. Each sample shall be retained in a sack or container, plainly labeled, showing depth from which sample was obtained and location of test hole from known referenced point. The Contractor shall obtain a sieve analysis on each sample taken. In case of abandonment, seal well with gristles clay, starting from the bottom by pumping to within 6 meters (or 20 ft.) of ground surface. Fill remaining 6 meters (or 20 ft.) with Portland cement by the Haliburton process or an alternate method approved by ESSO.
- c. A complete drilling log shall be available for each test hole. The Contractor shall maintain an accurate log of location of top and bottom of each stratum penetrated.

Well Materials

3.3 The water well components shall be made from the following materials:

- a. The main casing material shall consist of steel, API 5L Grade B or ASTM A53 Grade B, seamless, with standard couplings.
- b. Screen shall be Type 304 stainless steel, continuous slot, wire-wound design to provide maximum inlet area consistent with strength requirements. Exact screen gauge openings shall be determined after sieve analysis, if applicable, has been conducted on sand samples obtained from test hole.
- c. Blank pipe shall be installed between sand formations and 3 meters (or 10 ft.) below the bottom screen section. Blank pipe shall also extend above the bottom of main casing. Blank pipe shall be the same type and weight as screen pipe.
- d. Gravel shall be clean, well-rounded and graded, smooth and uniform having a specific gravity of 2.5 or greater. The grading shall meet the requirements of the screen manufacturer. The gravel shall be thoroughly disinfected with a 50mg/l chlorine solution as it is added to the well cavity. The gravel size shall be recommended by the Contractor after the results of the sieve analysis are obtained.
- # e. All other materials used such as drilling fluid and cement grout shall require ESSO's approval.

ESSO EXPLORATION & PRODUCTION CHAD INC. 	WATER WELLS	CCS 11-10-1 Page 6 of 10	
TECHNICAL SPECIFICATION		Rev. 0	04 Nov 96


Well Construction

3.4 Each water well shall be constructed to meet the following guidelines:

- a. For the entire depth of the main casing, ream well hole to a minimum 100 mm (4 inches) greater than the outer diameter of main casing. The main casing shall extend from 500 mm (1 ft. -8 in.) above the finished grade to the depth of the shallowest water bearing formation to be developed. The space between the casing and drill hole shall be completely sealed by using cementitious grout under pressure. Allow sufficient time for cement to properly set before cement plug is drilled.
- # b. After cement has set, underream with positive hydraulically operating expanding underreamer in continuous operation of water bearing formations which are to be used in completed well. Size of underreams shall be recommended by the Contractor and requires ESSO's approval. Hole which extends into impervious stratum underlying lower water bearing sand shall be 100 mm (4 inches) larger than outside diameter of screen and blank pipe. Set screen to coincide with and conform in length to the thickness of water bearing formations as determined by electric log. The well design shall ensure that the screen section is always fully submerged and that fluctuations in the elevation of the water level in the saturated zone have been taken into account.
- c. For water bearing sand formations a gravel wall filter is required. After screen and blank pipe are set in hole, fill annular space around outside of screen and blank pipe and inside of underreamed hole with well graded gravel. Convey gravel from hydraulic graveling machine to the point of deposit at the bottom of the well through graveling tube. As annular space on outside of screen and blank pipe are filled, gradually raise graveling tube to maintain bottom of graveling tube near point of deposit at all times. Deposit gravel to within 3 meters (or 10 ft.) from top of blank pipe.

Well Development

3.5 Following installation of the well, Contractor shall set test pump and conduct a continuous pumping test for a period of not less than 36 hours to establish well capacity, draw down, and recovery level for pump installation.

ESSO EXPLORATION & PRODUCTION CHAD INC. 	WATER WELLS	CCS 11-10-1 Page 7 of 10	
TECHNICAL SPECIFICATION		Rev. 0	04 Nov 96


- a. All equipment and power for testing shall be furnished by the Contractor. Equipment shall include a test pump with a capacity of 1.5 times the guaranteed yield, orifice meter for measuring quantity of water, air line and certified gauges calibrated in meters of water. ESSO shall be a advised of all testing.
- b. Should the test of the well indicate that the yield is below the minimum gallons per minute required, Contractor shall immediately take such steps that may be necessary to reconstruct or recondition the well to attain the required capacity yield.

Well Cleaning

- 3.6 After well development, contractor shall clean each well. To clean up the wells, tubing is run past the bottom of the screens and compressed air is pumped down the tubing. As the air returns up the annulus, it lifts the water and any small debris that may be inside the casing. If the well does not produce satisfactorily, the casing/tubing annulus can be blocked off and the compressed air forced through the screens and up through the gravel pack to back flush same. Water can also be pumped up through the gravel to flush same. Water can also be pumped through the gravel to flush out debris.
- 3.7 Wells should be cleaned by jetting with air for several days before running the submersible pump. Jetting removes any fine sand that may get through the screens.

Well Disinfection

- 3.8 After well has been developed and cleaned of sand and debris, Contractor shall thoroughly clean casing pipe by swabbing using alkalis, if necessary, to remove oil, grease, and lubricants. Contractor shall disinfect the well prior to use for potable water production by introduction of 50mg/liter chlorine solution into the well. The disinfectant shall be allowed to stand for 2 hours. Flushing water shall then be introduced at the bottom of the well forcing the chlorine solution out of the casing. After flushing, the well shall be pumped until there is no chlorine odor in the water. Disinfectant procedures shall comply with AWWA 654 and meet the World Health Organization Standards as per CCS 11-10-2.


ESSO EXPLORATION & PRODUCTION CHAD INC. 	WATER WELLS	CCS 11-10-1 Page 8 of 10	
TECHNICAL SPECIFICATION		Rev. 0	04 Nov 96

Well Testing

- # 3.9 Before final acceptance of the well, water tests shall be performed by an ESSO approved laboratory to ensure water is free of any unacceptable concentrations of harmful chemicals or microbiological contaminants including bacteria, viruses, protozoa and parasites.
- # a. Contractor shall take one sample on five successive days after well has been chlorinated and permanent pumping equipment installed and tested, and submit it to an ESSO approved laboratory for testing. Contractor shall re-disinfect water well until bacteria free samples are obtained.
- # b. Contractor shall collect sufficient samples of water for chemical analysis after the well is free of chlorine residual, determine pH and free carbon dioxide at time of sample collection at the well site and make other determinations in a laboratory. The Contractor shall submit a procedure to ESSO for approval for the treatment of any unacceptable concentrations of chemicals in the well water as per CCS 11-10-2.

Well Completion


- 3.10 To complete the well installation, the Contractor shall provide and install the following:
- a. To prevent ground water contamination, at least two well seals shall be installed within the annulus:
- (1.) One just above the screen, and
 - (2.) the other at the ground surface.
- Sealing material shall be suitable for the intended purpose and examples may be neat cement grout, dry bentonite, bentonite slurry or a mixture of a small amount of bentonite with neat cement.
- b. Install well pump as indicated on the drawings and in accordance with the manufacturer's instructions. If the permanent well pump cannot be installed within three days, a cap shall be welded temporarily to the top of the casing to protect the well from damage or contamination. The cap shall be removed when a permanent pump is installed.

ESSO EXPLORATION & PRODUCTION CHAD INC. 	WATER WELLS	CCS 11-10-1 Page 9 of 10	
TECHNICAL SPECIFICATION		Rev. 0	04 Nov 96

- c. Concrete sealing block shall be installed extending 1 meter (3 ft.) in all directions from the main casing. The block shall be a minimum of 150 mm (6 in.) thick and shall slope away from the wellhead at 20 mm per meter (1/4 in. per ft.).
- d. A well casing vent shall be provided with the opening screened with 16-mesh or finer stainless steel screen. The vent shall be turned downward and elevated above the pump base so as to minimize the drawing of contaminants into the well.
- e. Either an electric resistance tape or a water level measuring air line shall be installed and calibrated to permit monitoring of ground water levels.
- f. A sampling point shall be provided at a suitable location for taking samples for water quality monitoring.
- g. On completion of the work on water wells and prior to design of water treatment, the following shall be reported:
 - 1) Log of well drilling
 - 2) As-built drawings of wells, well pumps and other details.
 - 3) Final pump test results to verify capacity requirements have been met
 - 4) Results of chemical and bacteriological tests on water samples
 - 5) Verification of water treatment requirements originally planned


4.0 PUMP CONTROL

- 4.1 The system design shall incorporate the automatic operation of up to two well pumps. Each well pump shall start or stop as controlled by the storage water levels in fire water tank or potable/utility water reservoir reaching pre-determined elevation set points or by the hydropneumatic tank pressure reaching pre-determined set points.
- 4.2 The local pump panel (if required) shall be an IP66 enclosure.
- 4.3 Any additional well pumps shall be manually controlled remotely from the control room.

ESSO EXPLORATION & PRODUCTION CHAD INC. 	WATER WELLS	CCS 11-10-1 Page 10 of 10	
TECHNICAL SPECIFICATION		Rev. 0	04 Nov 96

5.0 WELL PUMPS AND MOTORS

- 5.1 Multi-stage submersible well pumps shall comply with AWWA E101.
- 5.2 Check valves shall be installed in pump discharge pipes.
- 5.3 Well pump motors shall comply with IEC in accordance with CCS 16-7-1 and CCS 16-9-1 and shall be stainless steel.
- 5.4 The power available will be 400 Volts, 3-phase, 50 Hz with the controls located in the station power house motor control center.
- 5.5 When running the submersible pump, care shall be taken to firmly secure the electric cable to the tubing. Very little slack shall be maintained when pulling the pump to be certain that the cable is coming up with the tubing.

ESSO EXPLORATION & PRODUCTION CHAD INC. 	POTABLE WATER TREATMENT, STORAGE AND DISTRIBUTION	CCS 11-10-2 Page 1 of 14	
TECHNICAL SPECIFICATION		Rev. 0	07 Nov 96

CHAD DEVELOPMENT PROJECT

TECHNICAL SPECIFICATION

Rev. No.	Date	No. of Pages	Prepared By	Reviewed By	Approved By	Revision Details
0	7 NOV 96	14	EHW	PRP	M.A.S	IFP Issue


ESSO EXPLORATION & PRODUCTION CHAD INC. 	POTABLE WATER TREATMENT, STORAGE AND DISTRIBUTION	CCS 11-10-2 Page 2 of 14	
TECHNICAL SPECIFICATION		Rev. 0	07 Nov 96

TABLE OF CONTENTS

1.0 SCOPE3

2.0 SUMMARY OF ADDITIONAL REQUIREMENTS3

3.0 SYSTEM DESIGN.....4

4.0 WATER TREATMENT5

5.0 TREATED WATER STORAGE TANK6

6.0 WATER PRESSURE TANK7

7.0 POTABLE/UTILITY WATER DISTRIBUTION PUMPS8


8.0 POTABLE WATER DISTRIBUTION SYSTEM.....9

9.0 VALVES.....11

LIST OF TABLES AND FIGURES

TABLE 1.....3

TABLE 2.....12

ESSO EXPLORATION & PRODUCTION CHAD INC. 	POTABLE WATER TREATMENT, STORAGE AND DISTRIBUTION	CCS 11-10-2 Page 3 of 14	
TECHNICAL SPECIFICATION		Rev. 0	07 Nov 96

1.0 SCOPE

- 1.1 This Specification covers the functional requirements for the potable/utility water treatment, storage and distribution systems.
- 1.2 A pound sign (#) indicates that ESSO review/approval is required before design and/or construction is finalized or equipment is purchased.

2.0 SUMMARY OF ADDITIONAL REQUIREMENTS

- 2.1 Table 1 lists the codes, standards and specifications which shall be used with this Specification.

TABLE 1

SPECIFICATIONS	
CCS	
3-7-1	Piping Flexibility and Supports
3-7-3	Thrust Blocks for Underground Cast Iron and Non-Metallic Pressure Pipe
3-12-1	Valve Selection Criteria
3-19-1	Piping Erection, Testing, Flushing and Cleaning
3-30-9	Specification for Piping Material Selection
4-9-1	Site Preparation and Earthwork
4-10-1	Concrete Design and Construction
11-10-1	Water Wells
15-0-100	General Instrument Specification
16-7-1	Motor Applications
16-9-1	AC Motors
16-101-1	Electrical Requirements for Packaged Mechanical Equipment
19-5-1	Cathodic Protection
19-1-10	Specification for Painting Aboveground Facilities
CODES AND STANDARDS	
ASME	
Section VIII,	
Div. 1	Boiler and Pressure Vessel Code, Pressure Vessels
B16.1	Cast Iron Pipe flanges and Flanged Fittings
ASTM	
A 53	Pipe, Steel, Black and Hot Dipped, Zinc Coated, Welded and Seamless
B88 (B88M)	Seamless Copper Water Tube (METRIC)
C 33	Concrete Aggregate
C 94	Ready Mix Concrete
D 2774	Underground Installation of Thermoplastic Pressure Piping
ACI	
301	Specifications for Structural Concrete
318	Building Code Requirements for Reinforced Concrete



ESSO EXPLORATION & PRODUCTION CHAD INC. 	POTABLE WATER TREATMENT, STORAGE AND DISTRIBUTION	CCS 11-10-2 Page 4 of 14	
TECHNICAL SPECIFICATION		Rev. 0	07 Nov 96

TABLE 1 (Cont'd)

AWWA	
B300 C200 C504 C508 C509 C651 C652 C653 C800 C900 C907 C950 D100 E101	Hypochlorites Steel Waterpipe - 150 mm and larger Butterfly Valves Check Valves Resilient Seated Gate Valve Disinfection of Water Mains Disinfection of Water Storage Facilities Disinfection of Water Treatment Facilities Water Service Pipe (Type K, Soft Copper Pipes) PVC Pipe Sizes 100 mm to 300 mm PVC Pressure Fittings for Water Fiberglass Pressure Pipe Welded Steel Tanks for Water Storage Vertical Turbine Pumps - Line Shaft and Submersible Types
PUBLICATIONS	
World Health Organization (1993) Guidelines for Drinking-Water Quality, 2nd Edition, Volume 1. Recommendations. Geneva, Switzerland Standard Methods for the Examination of Water and Wastewater, Mary Ann H. Franson, Editor, American Public Health Association, 19th Edition, 1995.	

3.0 SYSTEM DESIGN


- 3.1 The components of the water supply system shall include, but not be limited to:
- a. Water supply lines from source wells to storage tank.
 - b. A shelter for distribution pumps, water treatment, associated equipment and piping.
 - c. Water storage tank.
 - d. Water treatment equipment to provide the level of treatment necessary to comply with World Health Organization (WHO) Guidelines for Drinking-Water Quality, local regulations and the requirements of this specification, whichever is stricter. WHO Drinking-Water Quality Standards are listed in Table 2.
 - e. Underground water distribution mains and branch service lines
 - f. For very small systems, a precharged hydropneumatic tank and retention tank.
- 3.2 The water distribution system layout shall incorporate the following:
- a. The piping layout shall be looped wherever possible.
 - b. Valves shall be provided as follows:

ESSO EXPLORATION & PRODUCTION CHAD INC. 	POTABLE WATER TREATMENT, STORAGE AND DISTRIBUTION	CCS 11-10-2 Page 5 of 14	
TECHNICAL SPECIFICATION		Rev. 0	07 Nov 96

1. On all branch service lines
 2. On the mains at intervals sufficient to minimize disruption of service to consumers in the event of maintenance shut downs or breaks in the mains.
- 3.3 Potable/utility water mains shall be installed in a common trench with the fire water mains wherever feasible.
 - 3.4 The mains and branch services lines shall have a minimum of 1m (3 ft.) of earth cover. The structural design of the mains shall be based on additional live loads at all road crossings and other areas where heavy vehicles may cross them.
 - 3.5 Potable water system flow and pressure requirements in addition to process requirements, shall be as follows:
 - a. Community residents per capita consumption: 360 l/d (95 gpd)
 - b. Administration personnel per capita consumption: 76 l/d (20 gpd)
 - c. Plant workers per capita consumption: 114 l/d (30 gpd)
 - d. Operating pressure range during peak hour demand: 350 - 550 kPag (50 - 80 psig)
 - 3.6 The control panels, motors, and grounding shall be in accordance with Specification CCS 16-101-1.

4.0 WATER TREATMENT

- 4.1 Based on preliminary information, the proposed water treatment shall consist only of chlorination and pH adjustment. Additional treatment such as sedimentation, coagulation-flocculation, filtration, aeration and ion exchange process shall be provided by the Contractor, if necessary, to maintain the minimum drinking water standards as specified in this specification, local regulations, and WHO Guidelines for Drinking-Water Quality, whichever are stricter.
- #4.2 Chlorination shall be done using a hypochlorinator which utilizes Calcium Hypochlorite in powder or tablets. Proposals to use alternative methods of chlorination such as gas feed chlorinators shall be submitted to ESSO for approval.
- 4.3 The water treatment unit shall consist, as a minimum, of a complete chlorination system with automatic controls for disinfection in accordance with AWWA C653. Disinfection shall include a booster pump, metering pump, hypochlorinator, regulators, water flow meter, analyzer chloromatic valve, and controller instrumentation to automate the rate of chlorine injection. For pH adjustment, if necessary, provide pH analyzer and controller instrumentation to automate the dosage of additional agents for pH control.

ESSO EXPLORATION & PRODUCTION CHAD INC. 	POTABLE WATER TREATMENT, STORAGE AND DISTRIBUTION	CCS 11-10-2 Page 6 of 14	
TECHNICAL SPECIFICATION		Rev. 0	07 Nov 96

- 4.4 Chlorine shall be injected at a point which will provide a minimum contact time of 20 minutes to produce a free chlorine residual of 0.5 mg/l.
- 4.5 The treatment unit shall have dry contacts available for remote monitoring and alarms as specified on the data sheets. Parameters shall be covered within the unit system with an alarm and a shutdown.
- 4.6 Two chlorine booster pumps shall be provided (one operating, one standby).
- 4.7 Lab equipment for standard water analysis shall be supplied as required by the applicable AWWA standards. Methods of analysis shall be as in Standard Methods for the Examination of Water and Wastewater (1995).


5.0 TREATED WATER STORAGE TANK

- 5.1 A tank shall be used to store potable water. As a minimum, it shall be sized to hold a volume equal to the sum of the following:
 - a. Four hours of maximum daily flow for flow balancing.
 - b. Six hours of mean daily flow for emergency water.
 - c. One hour of mean daily flow for utility water.
- 5.2 Materials for tank construction shall be as follows:
 - a. Tank shall consist of steel plate construction with welded seams in compliance with AWWA D100. The tank shall include 750mm (30 in.) cleanout manway, 750mm (30 in.) roof hatch with hasp and padlock, inside ladder, outside ladder, screened vent, overflow piping, drain, inlet and outlet flanges, and a liquid level indicator.
 - b. Tank padding shall consist of asphalt impregnated fiberglass or oxidized asphalts, fiberglass, and selected mineral or organic fillers bonded together to form sheets. Material shall be dry, firm, non-tacky, and resistant to mild acids and alkalines.

5.3 Installation, Testing and Disinfection

Tank installation, testing and disinfection shall meet the following requirements:

- a. Concrete foundation shall be constructed in accordance with CCS 4-10-1.
- b. Place tank padding on top of compacted sand and concrete foundation and erect steel tank.

ESSO EXPLORATION & PRODUCTION CHAD INC. 	POTABLE WATER TREATMENT, STORAGE AND DISTRIBUTION	CCS 11-10-2 Page 7 of 14	
TECHNICAL SPECIFICATION		Rev. 0	07 Nov 96

- c. Painting of interior and exterior tank shall be in accordance with CCS 19-1-10. Allow a minimum of seven days following application of final coat on interior before tank is flushed, sterilized or filled.
- d. After tank has been erected and valves and piping installed, contractor shall test the tank for leakage, for a period of not less than 24 hours, by filling with water to maximum working water level. Leaks which are disclosed in the test shall be corrected and the test repeated until test results are satisfactory.
- #e. Contractor shall waterproof and thoroughly disinfect the ground storage tank and connecting lines with 50mg/l chlorine solution before placing in operation in accordance with AWWA C652. Valves in water lines being disinfected shall be opened and closed several times during the contact period. Following a contact period of 24 hours, heavily chlorinated water shall be flushed from the system with clean water. Disinfectant procedures require ESSO's approval.
- f. After refilling tank with potable water having chlorine content of not more than 1mg/l, take samples and submit for bacteriological testing. If samples are not free from coliform organisms repeat disinfection until tests comply with local regulations, WHO Guidelines for Drinking-Water Quality, and the requirements of this specification.

6.0 WATER PRESSURE TANK


6.1 General

Hydro-pneumatic tanks shall be used to control the cycling of pumps and to control pressure variations in the distribution system. Water is stored under pressure in the tanks and as a draw is made on the distribution system and pressure starts to drop, water flows from the tank into the systems to maintain pressure.

6.2 Materials

Materials for tank construction shall be as follows:

- a. Tank shall consist of steel plate construction with welded seams. prefabricated to include a manway, inlet/outlet flanges, relief and other valves, drain, gauge, sight glass and guard.
- b. Tank shall be designed, fabricated and tested in compliance with ASME Pressure Vessel Code, Section VIII, Division 1 (unfired pressure vessels). Design pressure shall be 689 kPag (100 psig) working pressure and sealed tank test pressure shall be 1034 kPag (150 psig). Painting the interior and exterior of the tank shall be in accordance with CCS 19-1-10.
- c. Tank shall have a flexible membrane between the air and the water, suitable for use with potable water systems.

ESSO EXPLORATION & PRODUCTION CHAD INC. 	POTABLE WATER TREATMENT, STORAGE AND DISTRIBUTION	CCS 11-10-2 Page 8 of 14	
TECHNICAL SPECIFICATION		Rev. 0	07 Nov 96

6.3 Controls

Controls shall include combination pressure tank control for operating pumps and compressor to accurately and automatically maintain correct air to water ratio in tank. Control shall include independent and adjustable pressure sensor for each pump start point and another for air control. Each pressure sensor set point shall be easily adjustable and consist of independent bellows which operate dustproof glass hermetically sealed snap acting switches and have a pressure range of 1034 kPag (150 psig).


6.4 Installation, Testing and Disinfection

Tank installation and testing shall meet the following requirements:

- a. Concrete foundation shall be constructed in accordance with CCS 4-10-1.
- b. Erect tank on level foundation, connect valves and piping.
- c. After tank has been erected and valves and piping installed, and before field painting is begun, subject valves and piping to hydrostatic pressure test in accordance with CCS 3-19-1 and CCS 3-30-9.
- d. Replace defective material disclosed by pressure test with sound material and repeat test until tank operation is satisfactory. Test tank in accordance with AWWA D100.
- e. Disinfect pressure tank and connecting lines with 50 mg/l chlorine solution in accordance with AWWA C652 before placing in operation.
- f. Following contact period of not less than 24 hours, flush heavily chlorinated water from system with clean water until residual chlorine content is not greater than 1mg/l.

7.0 POTABLE/UTILITY WATER DISTRIBUTION PUMPS

- 7.1 Minimum number of pumps shall be two; one duty pump and one spare. The pumps shall be electric motor driven, automatically controlled by system demands and pressures or by remote control and be capable of satisfying the peak hour water demand. The pump system shall be pressure controlled based on the pressure downstream of the pumps. Check valves shall be provided downstream of the distribution pumps to prevent backflow.

ESSO EXPLORATION & PRODUCTION CHAD INC. 	POTABLE WATER TREATMENT, STORAGE AND DISTRIBUTION	CCS 11-10-2 Page 9 of 14	
TECHNICAL SPECIFICATION		Rev. 0	07 Nov 96

- 7.2 The smallest pump shall be designed to function as a "jockey pump." This jockey pump shall maintain system pressure during low demand conditions with excess pressure relieved back into the storage reservoir.
- 7.3 The vertical turbine pumps shall comply with AWWA E101.
- 7.4 Pump motors shall comply with CCS 16-7-1 and CCS 16-9-1.
- 7.5 The power available will be 400 Volts, 50 Hz, 3 phase for motor duties up to 150 kW, with the contactors located in the station powerhouse motor control center.

8.0 POTABLE WATER DISTRIBUTION SYSTEM

8.1 General

Provisions for this Section apply to a potable water distribution system. Comply with pipe manufacturer installation instructions, manuals, and printed recommendations.

8.2 Piping Material


Piping material shall be in accordance with CCS 3-30-9 and shall be as follows:

- a. Galvanized steel pipe, shall be protected against external corrosion using single coat/single wrap or double coat/double wrap protective coating system. Cathodic protection shall be provided in accordance with CCS 19-5-1.
- b. PVC pipe shall not be used in areas where the ground may become contaminated with hydrocarbons in the future.

8.3 Piping Installation

Underground installation and testing by the Contractor shall meet the following requirements:

- a. Excavate pipe trench to the depth indicated on the construction drawings and in accordance with CCS 4-9-1. Provide trench bedding as indicated on the drawings and in accordance with CCS 4-9-1. Install Polyvinyl Chloride (PVC) Pipe in compliance with ASTM D2774. Install gaskets and necessary lubricants.
- b. Keep pipe clean during laying operations by plugging or other reviewed method. Do not lay pipe when it is raining or when trench is muddy, soft, or contains standing water.

ESSO EXPLORATION & PRODUCTION CHAD INC. 	POTABLE WATER TREATMENT, STORAGE AND DISTRIBUTION	CCS 11-10-2 Page 10 of 14	
TECHNICAL SPECIFICATION		Rev. 0	07 Nov 96

- c. Full length of each section of pipe shall rest solidly on bedding material with recesses excavated to accommodate bells and joints. Close open ends of pipe or fittings when work is not in progress so that trench water, earth, or substances will not enter pipe. Replace sections of pipe found to be defective, before or after laying, with sound pipe.
- d. Do not lay water pipe closer than 3 meters horizontally from sanitary sewer in parallel installations. Do not locate joints at cross-overs closer to sanitary sewer than 3 meters (9 ft.) from cross-over point. In either case, water pipe shall be above the elevation of adjacent sewer. Install concrete thrust blocking at bends and tees and at ends of lines to provide adequate reaction support. Place blocks so that joints will be accessible for inspection and repair.
- e. Set buried valves plumb and center on valve boxes. Where feasible, locate valves outside area of roads. Tighten stuffing boxes and test each valve in both the opened and closed position to ensure that parts are in working condition.


8.4 Pressure Testing

- a. Subject newly laid piping or valved section to hydrostatic pressure of 455 kPag (66 psig) for one hour. Make test after pipe is laid, joints completed but exposed for examination, and trench partially backfilled.
- b. Carefully examine exposed pipe, joints, fittings, and/or valves during pressure test. Tighten or remake joints showing visible leakage. Replace and re-test cracked or defective pipe, fittings and valves.

8.5 Disinfection

System disinfection shall be performed as follows:

- # a. After testing, disinfect entire distribution systems with 50mg/l chlorine solution in compliance with WHO requirements. Isolate a maximum area of 300 meters (or 1000 ft.) of piping from the rest of the system for disinfection. Thoroughly flush lines before introducing chlorine solution. Disinfectant procedures shall be in accordance with AWWA C651 and require ESSO's approval.
- b. After a contact period of not less than 24 hours, flush system with clean water until residual chlorine content is not greater than 1

ESSO EXPLORATION & PRODUCTION CHAD INC. 	POTABLE WATER TREATMENT, STORAGE AND DISTRIBUTION	CCS 11-10-2 Page 11 of 14	
TECHNICAL SPECIFICATION		Rev. 0	07 Nov 96

mg/l. Open and close all valves in lines being sterilized several times during contact period.

- c. Collect samples for bacteriological analysis to check efficiency of disinfection procedures. Take minimum on one sample for each 300 meters (or 1000 ft.) of completed water main. Repeat disinfection process and sample collection if tests show that contamination persists.

9.0 VALVES

General

- 9.1 Valves shall be resilient seated gate valves, and shall conform to AWWA C509 standard. The exterior of the valve shall be factory coated. They shall be standard iron body, resilient rubber seated rings, modified solid disc with non-rising stem.
- 9.2 In-ground valves shall be located in a valve box accessible to the operator for operation and maintenance.

Pressure Reducing Valves

- 9.3 Pressure reducing valves shall maintain a constant downstream pressure regardless of varying inlet pressure. Pressure reducing valves shall be standard iron body, hydraulically operated, diaphragm actuated, globe valves with stainless steel trim seats, external position indicator, Class 125 ANSI B16.1 flanges with 6 mm pet cocks on the inlet and outlet side of the valve. The pilot control system shall have an external strainer and direct acting, spring loaded, normally open diaphragm valve.

Check Valves

- 9.4 All check valves shall conform to AWWA C508 and CCS 3-30-9 and shall be iron-body bronze mounted swing check valves complete with outside lever and weight.


ESSO EXPLORATION & PRODUCTION CHAD INC. 	POTABLE WATER TREATMENT, STORAGE AND DISTRIBUTION	CCS 11-10-2 Page 12 of 14	
TECHNICAL SPECIFICATION		Rev. 0	07 Nov 96

TABLE 2

World Health Organization Guidelines for Drinking Water Quality		
Parameters	Design Standard	
Turbidity	5 NTU	Note - (a) (b)
Color	15 time color units	Note - (b)
Odor	Inoffensive odor	3 T.O.N.
pH	6.5 - 8.5	
Chlorines	5 mg/L, 0.6 - 1 mg/L	Note - (b)
Monochloramine	3 mg/L	
Total Dissolved Solids	1000 mg/L	Note - (b)
Total Coliform	0 per 100 ml	Note - (c)
Selenium	0.01 mg/L	
Hydrogen Sulfide (H ₂ S)	0.05 mg/L	Note - (b)
Inorganics		
Nitrates (NO ₃)	50 mg/L	
Nitrites (NO ₂)	3 mg/L	
Ammonium (NH ₄)	1.5 mg/L	Note - (b)
Sulphates (SO ₄)	250 mg/L	Note - (b)
Sodium (Na)	200 mg/L	Note - (b)
Aluminum (Al Total)	0.2 mg/L	Note - (b)
Chlorides (Cl)	250 mg/L	Note - (b)
Cyanides (CN)	0.07 mg/L	
Fluoride (F)	1.5 mg/L	
Chromium (total)	0.05 mg/L	
Iron (Fe)	0.3 mg/L	Note - (b)
Nickel (Ni)	0.2 mg/L	
Copper (Cu)	2 mg/L, 1 mg/L	Note - (b)
Zinc (Zn)	5 mg/L, 3 mg/L	Note - (b)
Arsenic (As)	0.01 mg/L	
Cadmium (Cd)	0.003 mg/L	
Manganese (Mn)	0.5 mg/L, 0.1 mg/L	Note - (b)
Mercury (Hg)	0.001 mg/L	
Barium (Ba)	0.7 mg/L	
Lead (Pb)	0.01 mg/L	
Antimony (Sb)	0.005 mg/L	
Boron (B)	0.3 mg/L	
Molybdenum (Mo)	0.07 mg/L	
Aromatic Compounds		
Benzene	0.01 mg/L	
Ethylbenzene	0.3 mg/L, 2-200 µg/L	Note - (b)
Toluene	0.7 mg/L, 24-170 µg/L	Note - (b)
Xylene	0.5 mg/L, 20-1800 µg/L	Note - (b)
Styrene	20 µg/L, 4-2600 µg/L	Note - (b)
Benzo[a]pyrene	0.7 µg/L	
Chlorinated Alkanes		
Carbon Tetrachloride	2 µg/L	
Dichloromethane	20 µg/L	
1,2 - Dichloroethane	30 µg/L	
1,1,1 - Trichloroethane	2000 µg/L	


ESSO EXPLORATION & PRODUCTION CHAD INC. 	POTABLE WATER TREATMENT, STORAGE AND DISTRIBUTION	CCS 11-10-2 Page 13 of 14	
		TECHNICAL SPECIFICATION	Rev. 0

TABLE 2 (Cont'd)

World Health Organization Guidelines for Drinking Water Quality		
Parameters	Design Standard	
Chlorinated Ethenes		
Vinyl Chloride	5 µg/L	
1,1 - Dichloroethene	30 µg/L	
1,2 - Dichloroethene	50 µ/L	
Trichloroethene	70 µg/L	
Tetrachloroethane	40 µg/L	
Chlorinated Benzenes		
Monochlorobenzene	300 µg/L, 10 - 120 µg/L	Note - (b)
1,2 - Dichlorobenzene	1000 µg/L, 1 -10 µg/L	Note - (b)
1,4 - Dichlorobenzene	300 µg/L, 0.3 - 30 µg/L	Note - (b)
Trichlorobenzenes (Total)	20 µg/L, 5 - 50 µg/L	Note - (b)
Disinfectant By-Products		
Bromate	25 µg/L	
Chlorite	200 µg/L	
2-Chlorophenol	0.1 - 10 µg/L	Note - (b)
2,4-Dichlorophenol	0.3-40 µg/L	Note - (b)
2,4,6 - Trichlorophenol	200 µg/L, 2-300 µg/L	Note - (b)
Formaldehyde	900 µg/L	
Bromoform	100 µg/L	
Dibromochloromethane	100 µg/L	
Bromodichloromethane	60 µg/L	
Chloroform	200 µg/L	
Dichloroacetic Acid	50 µg/L	
Trichloroacetic Acid	100 µg/L	
Chloral Hydrate (Trichloroacetaldehyde)	10 µg/L	
Pesticides		
Alachlor	20 µg/L	
Aldicarb	10 µg/L	
Aldrin/Dieldrin	0.03 µg/L	
Atrazine	2 µg/L	
Bentazone	30 µg/L	
Carbofuran	5 µg/L	
Chlordane	0.2 µg/L	
Chlorotoluron	30 µg/L	
DDT	2 µg/L	
1,2-Dibromo-3-Chloropropane	1 µg/L	
2,4-D	30 µg/L	
1,2-Dichloropropane	20 µg/L	
1,3-Dichloropropene	20 µg/L	
Heptachlor and Heptachlor	0.03 µg/L	
Hexachlorobenzene	1 µg/L	
Isoproturon	9 µg/L	
Pesticides (Cont'd)		
Lindane	2 µg/L	
MCPA	2 µg/L	



ESSO EXPLORATION & PRODUCTION CHAD INC. 	POTABLE WATER TREATMENT, STORAGE AND DISTRIBUTION	CCS 11-10-2 Page 14 of 14	
		TECHNICAL SPECIFICATION	Rev. 0

TABLE 2 (Cont'd)

World Health Organization Guidelines for Drinking Water Quality	
Parameters	Design Standard
Methoxychlor	20 µg/L
Metolachlor	10 µg/L
Molinate	6 µg/L
Pendimethalin	20 µg/L
Pentachlorophenol	9 µg/L
Permethrin	20 µg/L
Propanil	20 µg/L
Pyridate	100 µg/L
Simazine	2 µg/L
Trifluralin	20 µg/L
Chlorophenoxy Herbicides Other than 2,4-D and MCPA 2,4-DB	90 µg/L
Dichlorprop	100 µg/L
Fenoprop	9 µg/L
Mecoprop	10 µg/L
2,4,5-T	9 µg/L
Miscellaneous	
Di(2-ethylhexyl)adipate	80 µg/L
Di(2-ethylhexyl)phthalate	8 µg/L
Acrylamide	0.5 µg/L
Epichlorohydrin	0.4 µg/L
Hexachlorobutadiene	0.6 µg/L
Edetic Acid (EDTA)	200 µg/L
Nitrilotriacetic Acid	200 µg/L
Tributyltin Oxides	2 µg/L

- Notes:
- NTU = Nephelometric Turbidity Units
 - The range given (or second value listed) shows preferred aesthetically-based values
 - No more than 5% of the samples per month may be positive. If less than 90 samples, no more than one can be positive.

ESSO EXPLORATION & PRODUCTION CHAD INC. 	PACKAGED SEWAGE TREATMENT SYSTEM	CCS 11-11-1 Page 1 of 13	
TECHNICAL SPECIFICATION		Rev. 0	07 Nov 96

CHAD DEVELOPMENT PROJECT

TECHNICAL SPECIFICATION

Rev. No.	Date	No. of Pages	Prepared By	Reviewed By	Approved By	Revision Details
0	7 NOV 96	13	EHW	PRF	MOS	IFP Issue



ESSO EXPLORATION & PRODUCTION CHAD INC. 	PACKAGED SEWAGE TREATMENT SYSTEM	CCS 11-11-1 Page 2 of 13	
TECHNICAL SPECIFICATION		Rev. 0	07 Nov 96

TABLE OF CONTENTS

1.0 SCOPE	2
2.0 SUMMARY OF ADDITIONAL REQUIREMENTS	3
3.0 STRUCTURAL	4
4.0 CORROSION PROTECTION	5
5.0 ELECTRICAL SYSTEM	5
6.0 MECHANICAL	5
7.0 PIPING	6
8.0 INSTRUMENTATION	6
9.0 UNIT PROCESSES	7
10.0 UNIT PROCESS SPECIFICATIONS	7
11.0 NOISE	11
12.0 START-UP AND OPERATING INSTRUCTIONS	11

LIST OF TABLES

TABLE 1	4
TABLE 2	10

ESSO EXPLORATION & PRODUCTION CHAD INC. 	PACKAGED SEWAGE TREATMENT SYSTEM	CCS 11-11-1 Page 3 of 13	
TECHNICAL SPECIFICATION		Rev. 0	07 Nov 96

1.0 SCOPE

- 1.1 This Specification covers the design and manufacture of a factory built, skid mounted, transportable, sewage treatment unit(s) which will be used for the treatment of sanitary waste from operations camps and facilities in Chad and Cameroon, Africa. Skid mounted components may be designed for modular assembly and installation. The treatment plant shall be prefabricated in the factory of the supplier and shall be shipped complete with all equipment specified herein.
- 1.2 Not included in this specification are the upstream sewer piping and lift station and downstream discharge piping.
- 1.3 A pound sign (#) indicates that ESSO review/approval is required before design and/or construction is finalized or equipment is purchased.
- #1.4 Alternative designs and specifications are encouraged as long as the design or specification is equivalent to the requirements specified. Alternative designs and specifications require ESSO's approval.
- 1.5 The treatment system shall be suitable for outdoor installation in a tropical climate and shall be of a design with proven operability and durability in environmental conditions equal to or more severe than the design operating conditions.
- 1.6 Data sheets are supplied with this specification.

2.0 SUMMARY OF ADDITIONAL REQUIREMENTS

- 2.1 Table 1 lists the codes, specifications, standards and publications which shall be used with this Specification.



ESSO EXPLORATION & PRODUCTION CHAD INC. 	PACKAGED SEWAGE TREATMENT SYSTEM	CCS 11-11-1 Page 4 of 13	
TECHNICAL SPECIFICATION		Rev. 0	07 Nov 96

TABLE 1

SPECIFICATIONS	
CCS	
2-1-1	Equipment Noise Level Data Requirements
4-1-2	Structural Steel Design, Fabrication and Erection
4-2-1	Design Loads for Structures
9-4-201	Production Tanks, Nominal Capacities Below 2,000 bbl.
10-19-1	Packaged Equipment
15-1-5	Packaged Equipment Instrumentation
16-3-1	Wiring Methods and Material Selection
16-9-1	AC Motors
16-101-1	Electrical Requirements for Packaged Mechanical Equipment
20-1-1	Inspection of Equipment and Materials
CODES AND STANDARDS	
SSPC	
SP 6	Surface Preparation Specification No. 6 Commercial Blast Cleaning
SP 10	Surface Preparation Specification No. 10 Near-White Blast Cleaning
AISC	
M016	Manual of Steel Construction Allowable Stress Design
AWS	
D1.1	Structural Welding Code Steel
ASCE	
7	Minimum Design Loads for Buildings and Other Structures
ASME	
Section VIII, Div. 1	Boiler and Pressure Vessel Code
B 16.5	Pipe Flanges and Flanged Fittings
B 1.20.1	Pipe Threads, General Purpose
OSHA	
29 CFR Part 1926	
AGMA	
390.03	Gear Classification

3.0 STRUCTURAL

Design of non-pressure parts shall be based on the guidelines from the AISC Steel Construction Manual, and CCS 4-1-2. The treatment Plant shall be built of 6 mm (1/4 in.) minimum thickness structural grade A36 steel plate and shall be designed to withstand normal hydrostatic pressures. All welded structural members shall be in accordance with AWS D1.1, structural welding code using E-70XX electrodes. Welds shall be continuous inside and out where required for structural strength or water

ESSO EXPLORATION & PRODUCTION CHAD INC. 	PACKAGED SEWAGE TREATMENT SYSTEM	CCS 11-11-1 Page 5 of 13	
TECHNICAL SPECIFICATION		Rev. 0	07 Nov 96

tightness. Attachment welds shall be of the same specification, grade and heat treatment condition as the plate material used to fabricate the major components. The structural components shall be joined by welding as described above and shall meet AISC and AWS welded joint requirements.

The treatment plant shall be hydrostatically tested per governing code. The hydrostatic test shall be performed prior to external coating, with chlorine controlled water (50 ppm max.) where stainless steel is in contact with the testing medium.

4.0 CORROSION PROTECTION

Surfaces immersed in water shall be prepared in accordance with SSPC SP-10 and other surfaces shall be per SSPC SP-6. Prepared surfaces shall be primed with a 75 μm (3 mil) coat of Carbozinc 11 primer and a 75 μm (3 mil) coat of Carboline finish coat. Painting shall be in accordance with CCS 19-1-10.

5.0 ELECTRICAL SYSTEM

The treatment plant shall be completely prewired at the supplier's factory and shall be in accordance with IEC Standards and meet the requirements of specification CCS 16-101-1 (Electrical Requirements for Packaged Mechanical Equipment). Electrical enclosures shall be IP66. Motors shall be provided with 1.15 service factor, shall be TEFC, and shall be in accordance with CCS16-9-1.

6.0 MECHANICAL

Pumps shall be suitable for use in sewage application. Selection of the pump shall be based on its intended service (recessed impeller, diaphragm, metering, etc.)


Motor drivers shall be suitable for the area classification. The motors shall be designed per IEC standards. Motors shall be standard sizes and readily available.

Vessels shall be sized for the volume or holding time required for the proper operation of the system. Materials shall be compatible with sanitary sewage. Construction shall be industry standard.

Supplier's standard materials are acceptable; as long as Supplier shall furnish material equal to or better than the material specified herein.

Mechanical drives shall be gear reduction type with gears that conform to AGMA gear classification for continuous duty.

Drives shall be enclosed in suitable housings with seals between the rotating and fixed components to prevent oil leakage.

ESSO EXPLORATION & PRODUCTION CHAD INC. 	PACKAGED SEWAGE TREATMENT SYSTEM	CCS 11-11-1 Page 6 of 13	
TECHNICAL SPECIFICATION		Rev. 0	07 Nov 96

Torque ratings for the drive shall be based on standard design criteria accepted and used in the gear industry and shall be limited by the strength or surface durability, whichever is least.

Machinery shall operate under all conditions without excessive vibration.

All grease fittings, oil fill, and drain points shall be extended for easy access and service form walkway or operating platform without raising floor plates.

7.0 PIPING

Piping shall be arranged so that no liquid pockets or vapor traps are installed. Block valves shall be provided to isolate principal skid termination points for inspection and maintenance. Flanged connections shall be provided for the skid battery limit. Butterfly valves shall not be used where positive shut-off is required. Piping and fittings shall be located in the confines of the skid and supported in such a way as to avoid unacceptable vibration, stresses or loads on equipment. Sufficient 19 mm (3/4 inch) vents and drains with corrosion resistant plugs shall be provided for hydrostatic testing and purging prior to start-up. Sufficient 19 mm (3/4 inch) or larger valved vents and drains shall be provided to permit ease of start-up and shutdown. Sampling ports between processes and at the effluent discharge shall be provided.

Piping shall be per supplier's standard practice and this specification.


Pipe connections 50 mm (2 in.) and larger shall be flanged. Flanges shall be in accordance with ASME B 16.5. Flange bolt holes shall straddle natural centerline. Two bolt pipe flanges shall not be used.

Cast iron piping materials shall not be used.

Unless otherwise specified, minimum wall thickness shall be Schedule 80 for 50 mm (2 in.) nominal and smaller, Schedule 40 for 3 inches and larger. Nominal pipe sizes of 30 mm (1 1/4 in.), 60 mm (2 1/2 in.), 90 mm (3 1/2 in.), and 125 mm (5 in.) shall not be used.

8.0 INSTRUMENTATION

The treatment plant control system and instrumentation shall be designed so that the plant is capable of unattended operation, except for maintenance and periodic oversight. Supplier shall provide all necessary instrumentation for operation and testing of the system. All instrumentation shall be in accordance with CCS 15-1-5 and CCS 15-0-100. All instrumentation and associated junction boxes shall be rated for IP66.

ESSO EXPLORATION & PRODUCTION CHAD INC. 	PACKAGED SEWAGE TREATMENT SYSTEM	CCS 11-11-1 Page 7 of 13	
TECHNICAL SPECIFICATION		Rev. 0	07 Nov 96

9.0 UNIT PROCESSES

The unit processes shall consist of, but not be limited to:

- A coarse screen
- A comminutor/grinder.
- Biological activated sludge, suspended growth, complete mix unit process with contact stabilization or extended aeration
- Settling basin
- Sludge wasting system
- Chlorine contactor

10.0 UNIT PROCESS SPECIFICATIONS

10.1 Coarse Screen

The coarse screen shall have a screen opening of 19 mm (3/4 inch). A manual or automatic means for removing solids and cleaning the screen shall be provided.


10.2 Comminutor/Grinder

The comminutor/grinder shall be designed to prevent solids larger than 6 mm (1/4 inch) from passing.

10.3 Biological Treatment Unit

The biological treatment unit shall be the activated sludge, suspended growth process with the following design basis:

- The sewage consists of liquid sanitary waste originating from the kitchen sinks, lavatories, showers, urinals and toilets.
- Water Temperature is expected to vary from 10° C to 32° C
- Flow shall be based on 360 liters (95 gallons) of wastewater generated per person assigned to the camp or facility, per day.
- The design shall be based on a mean cell residence time of not less than 5 days.
- Mixed liquor volatile suspended solids (MLVSS) are 1500 mg/L and mixed liquor suspended solids (MLSS) are 1600 mg/L.

ESSO EXPLORATION & PRODUCTION CHAD INC. 	PACKAGED SEWAGE TREATMENT SYSTEM	CCS 11-11-1 Page 8 of 13	
TECHNICAL SPECIFICATION		Rev. 0	07 Nov 96

- Influent BOD₅ shall be 250 mg/l (30 day avg.).
- Cell yield coefficient Y (MLVSS/BOD₅) equals 0.71 and the endogenous decay coefficient b (1/t) equals 0.064 days⁻¹.
- Minimum air requirements are 1.1 Kg air/Kg BOD₅ removed. Average dissolved oxygen (DO) concentration of 2.0 mg/L shall be maintained.

Air requirements may be provided by blower/diffuser system, mixer, induced air, or combination thereof. The air distribution system shall be designed to evenly distribute air over the entire length of the aeration tank. Air diffusers, if part of the system, shall be the fine bubble (for shallow tank), non-clog type, operational between 122 and 490 SCM/d (3 and 12 scfm) per diffuser. Each assembly shall be designed and installed such that non "in-situ" replacement will not impact unit operations.

10.4 Secondary Clarification


The secondary clarifier shall be based on the following design criteria:

- Overflow rate shall not exceed 24 m³/m²-d
- Minimum tank depth shall be 3 m.
- Sludge Volume Index equals 150
- Solids loading rate shall not exceed 6 Kg/m²- hr

The data noted above constitutes Clarifier Data Sheet information.

The clarifier shall include, but not be limited to, the following:

- Tank
- Feedwell
- Bottom Rake Assembly and Lifting Devices
- Skimmer and Scum Trough
- Drive Mechanisms and Speed Reducer Effluent Weir
- Walkways and Ladders of Stairways.
- Overload Alarm and Control System
- Piping and Valving

ESSO EXPLORATION & PRODUCTION CHAD INC. 	PACKAGED SEWAGE TREATMENT SYSTEM	CCS 11-11-1 Page 9 of 13	
TECHNICAL SPECIFICATION		Rev. 0	07 Nov 96

The Clarifier/Thickener shall be Supplier's standard design, modified as required to comply with this specification. Major equipment shall be of proven design with a minimum of 2 years of successful operation in equal to or more severe than design operating conditions.

All gears and bearings shall run in an oil bath.

Drive units shall be furnished with overload protecting device(s) that shall visually indicate relative load by suitable means. When overloaded, an alarm shall be activated and the motor shall be de-energized. The loads where the alarm and motor cut-off occur shall be independently adjustable.

The Clarifier/Thickener shall be fabricated, assembled, and tested at the supplier's factory to the maximum extent feasible to minimize field installation and startup time. The system shall be complete with all structural supports, controls, instrumentation, piping, wiring, and components mounted.

Equipment and piping shall be arranged so that when installed, all external and internal components requiring manipulation, observation, and maintenance shall be readily accessible and safe to operating and maintenance personnel.

Supplier shall provide any special tools required for maintenance and servicing of the equipment. The tools shall be new and not used for construction.

Provisions shall be made for the removal of bottom sludge during maintenance periods by scouring.

10.5 Sludge Wasting System


Supplier shall provide a method for wasting and dewatering excess sludge from the clarifier underflow. Water from the dewatering process shall be returned to the biological treatment unit. Dewatered sludge will be landfilled or landspread into suitable soil.

10.6 Return Activated Sludge (RAS)

Supplier shall provide a system for returning activated sludge from the clarifier underflow to the biological treatment unit. The system shall be capable of returning RAS at a rate equal to 100% of the treatment unit flow rate and shall be capable of operating when turned down to 20% of the treatment unit flow rate.

10.7 Chlorination

Supplier shall provide a disinfection tank with baffles to prevent short circuiting. The chlorine tank shall have sufficient capacity for 30 minutes retention time at the average hourly design flow. The chlorinator shall consist of a compact

ESSO EXPLORATION & PRODUCTION CHAD INC. 	PACKAGED SEWAGE TREATMENT SYSTEM	CCS 11-11-1 Page 10 of 13	
TECHNICAL SPECIFICATION		Rev. 0	07 Nov 96

chlorinator box which dispenses a predetermined, stable quantity of chlorine from a tablet form. The chlorinator shall be manufactured of high density cross-linked polyethylene or stainless steel for durability and corrosion resistance. The chlorinator shall be designed to assure good contact between the water and disinfectant tablets, and to permit the free flow of water through the unit. Chlorine shall be injected at a rate of 2-5 mg/L at a point which will provide a minimum contact time of 30 minutes prior to discharge.

10.8 Walkways

The treatment plant shall be equipped with walkways, steps, ladders and handrails meeting OSHA standards and CCS 4-2-1. The walkways, steps, ladders and handrails shall be of galvanized steel, aluminum or fiberglass construction.

10.9 Effluent Criteria

Effluent shall meet World Bank effluent guidelines for onshore oil and gas development. Table 2 highlights key World Bank effluent criteria. The system shall include provisions for ensuring that effluent criteria are met during periods of system start-up and upsets.


TABLE 2

World Bank Liquid Effluent Criteria¹

Parameter	Maximum Levels
pH	6-9
BOD ₅	50 mg/L
Oil and Grease	20 mg/L
Heavy Metals (except Barium)	10 mg/L
Phenolic Compounds	100 mg/L
Total Suspended Solids	50 mg/L
Coliform Bacteria	400 MPN/100 mL ² (MPN - Most Probable Number)
Temperature - at the edge of the mixing zone	Max. 5° C above ambient temperature of receiving waters - Max. 3° C if receiving waters >28°C.

Source: The World Bank Environment, Health and Safety, Guidelines, Onshore Oil and Gas Development (World Bank, 1995)

1. Maximum daily discharge limits
2. Average monthly concentration (i.e., 30 consecutive days of sampling)

ESSO EXPLORATION & PRODUCTION CHAD INC. 	PACKAGED SEWAGE TREATMENT SYSTEM	CCS 11-11-1 Page 11 of 13	
TECHNICAL SPECIFICATION		Rev. 0	07 Nov 96

10.10 Discharge

Discharge of treated fluids will be to perennial surface waters or to absorption/evaporation system. Discharge will be performed in a manner that avoids erosion.

11.0 NOISE

The system noise shall not exceed 85 dBA and must be in accordance with CCS 2-1-1.

12.0 START-UP AND OPERATING INSTRUCTIONS

The manufacturer shall provide detailed operating and installation instructions. A trained representative shall also be provided to perform initial plant start-up and to assist the Contractor and/or ESSO in the operation and maintenance of the plant.

13.0 IDENTIFICATION AND TAGGING

Identification and Tagging shall conform to CCS 10-19-1.

14.0 INSPECTION AND TESTING

Inspection and testing shall conform to CCS 20-1-1.

15.0 PERFORMANCE GUARANTEE

Contractor shall guarantee that the system provided meets the requirements of the World Bank for effluent quality and functional performance of this specification. The Contractor shall immediately correct any deficiencies in the equipment or its performance.

SPECIFICATION SHEET
PACKAGE SEWAGE TREATMENT
SYSTEM

TAG NO. _____
 SHEET _____ OF _____
 BY PROCESS _____
 MECK _____
 REV. _____ DATE _____

CLIENT _____ SPEC. NO. _____ CONTRACT _____

1 NO. OF UNITS _____ MFR. MODEL NO. _____

2 SERVICE _____ MANUFACTURER _____

3 _____ PROCESS DATA

4 PLANT CAPACITY: NORMAL _____ GPD MAX. _____ GPD

5 PLANT INFLUENT: BOD₅ _____ mg/L SUSPENDED SOLIDS _____ mg/L

6 OTHER _____

7 PLANT EFFLUENT: BOD₅ _____ mg/L SUSPENDED SOLIDS _____ mg/L

8 OTHER _____

9 TYPE OF PLANT: ACTIVATED SLUDGE _____ CONTACT STABILIZATION _____

10 EXTENDED AERATION _____ PHYSICAL-CHEMICAL _____

11 OTHER _____

12 _____ MECHANICAL DESIGN

13 PLANT SIZE: LENGTH _____ WIDTH _____

14 HEIGHT _____ DIAMETER _____

15 PLANT TO INCLUDE THE FOLLOWING ITEMS. (NOTE SIZE OR VOLUME)

16 EQUALIZATION TANK: _____ CHLORINE CONTACT CHAMBER: _____

17 FLOCCULATION & COAGULATION: _____ AERATION TANK: _____

18 CLARIFIER: _____ SLUDGE HOLDING TANK: _____

19 TUBE SETTLERS: _____ SLUDGE THICKENING: FROM _____ % TO _____ % SOLIDS

20 FILTERS: GRAVITY _____ BY: CENTRIFUGE _____ FLOTATION _____

21 PRESSURE _____ GRAVITY _____ CONT. BELT FILTER _____

22 MATERIALS OF CONSTRUCTION _____

23 _____

24 _____

25 BLOWER(S): NO. _____ CFM _____

26 POSITIVE DISPL. _____ CENTRIFUGAL _____

27 ITEMS TO BE INCLUDED BY MANUFACTURER

28 CONTROL PANEL _____ ACTIVATED CARBON _____ SKID MOUNT _____

29 FLOW TOTALIZER _____ SLUDGE RECIRCULATION _____ SCUM BAFFLE _____

30 COMMINUTOR _____ AUTO.SLUDGE B.O. _____ ADJ. WEIR _____

31 BAR SCREEN _____ CHEM. FEED TANKS _____

32 FROTH SPRAY _____ CHEM. FEED PUMP & DR. _____

33 OTHER _____

34 _____

35 INSTRUMENTATION: _____

36 _____

37 MOTORS:

38 POWER AVAILABLE: VOLTS _____, PHASE _____, Hz _____

39 BLOWER(S) HP _____ / _____ VOLTS CONTROL PANEL: VOLTS _____

40 COMMINUTOR: HP _____ / _____ VOLTS OTHER _____

41 SLUDGE RECIR: HP _____ / _____ VOLTS

42 NOZZLES: INLET: SIZE _____, RATING _____

43 OUTLET: SIZE _____, RATING _____

44 SLUDGE REMOVAL: SIZE _____, RATING _____

45 OTHERS: _____


46 OPERATING WEIGHT _____, SHIPPING WT. _____, CUBAGE _____ CU. FT.

47 MATERIALS OF CONSTRUCTION: _____

48 _____

49 _____


50 _____


 ESSO EXPLORATION & PRODUCTION CHAD INC.	PACKAGED SEWAGE TREATMENT SYSTEM	CCS 11-11-1 Page 12 of 13	
	TECHNICAL SPECIFICATION	Rev 0	07 Nov 96

TAG NO. _____
 SHEET _____ OF _____
 BY PROCESS _____
 MECH. _____
 REV. _____ DATE _____

SPECIFICATION SHEET
 PACKAGE SEWAGE TREATMENT
 SYSTEM (Continued)

- 61 PAINTING: INTERNAL PRIME _____, FINISH _____, OTHER _____
- 52 EXTERNAL PRIME _____, FINISH _____, OTHER _____
- 53 REFERENCE OTHER EQUIPMENT SPECIFICATION SHEETS _____
- 54 _____
- 55 _____
- 56 REMARKS: _____
- 57 _____
- 58 _____
- 59 _____
- 60 SKETCH:

ESSO EXPLORATION & PRODUCTION CHAD INC. 	PACKAGED SEWAGE TREATMENT SYSTEM	CCS 11-11-1 Page 13 of 13
TECHNICAL SPECIFICATION		Rev. 0 07 Nov 96

ESSO EXPLORATION & PRODUCTION CHAD INC. 	SOLID WASTE LANDFILL	CCS 13-4-1 Page 1 of 27	
TECHNICAL SPECIFICATION		Rev. 0	11 Nov 96

CHAD DEVELOPMENT PROJECT

TECHNICAL SPECIFICATION

Rev. No.	Date	No. of Pages	Prepared By	Reviewed By	Approved By	Revision Details
0	11 NOV 96	27	EHW	PRF	MOS	IFP Issue



ESSO EXPLORATION & PRODUCTION CHAD INC. 	SOLID WASTE LANDFILL	CCS 13-4-1 Page 2 of 27	
TECHNICAL SPECIFICATION		Rev. 0	11 Nov 96

TABLE OF CONTENTS

1.0 SCOPE	3
2.0 SUMMARY OF ADDITIONAL REQUIREMENTS	3
3.0 PURPOSE OF SOLID WASTE LANDFILL	4
4.0 SITE SELECTION	4
5.0 DESIGN AND CONSTRUCTION CRITERIA	5
6.0 OPERATING PROCEDURES	19
7.0 CLOSURE REQUIREMENTS	26

LIST OF TABLES

TABLE 1.....	3
TABLE 2.....	7
TABLE 3.....	20
TABLE 4.....	23

ESSO EXPLORATION & PRODUCTION CHAD INC. 	SOLID WASTE LANDFILL	CCS 13-4-1 Page 5 of 27	
TECHNICAL SPECIFICATION		Rev. 0	11 Nov 96

- d. The landfill must be at least 300 m (1,000 ft.) from any non-intermittent water course or other permanent water-body.
- e. The landfill shall not be constructed within 500 m (1640 ft.) radius of any water supply well.
- f. The landfill shall not be located within 60 m (200 ft.) of geological fault areas.
- g. Avoid locations which have unstable subgrades and are likely to provide poor foundation conditions or are threatened by massive earth movements (e.g. landslides).
- h. The site shall have adequate room to accommodate the volume of wastes, berms, perimeter ditches, buffer zones, space for groundwater monitoring wells and access roads.
- i. On the basis of hydrogeological investigations, the site shall have a vertical separation between the seasonal high water table and the landfill bottom of greater than 1.5 m (5 ft.).
- j. The site shall not be located in a recharge area of an unconfined aquifer.
- k. The material that underlies the landfill shall have a hydraulic conductivity of not more than 10^{-6} cm/s.
- l. The site shall be located in an area where there will not be significant lateral transfer of mobilized contaminants in the groundwater.
- m. The selected location shall be such that natural erosion or future land use will be unlikely to excavate or expose buried waste and where groundwater is not susceptible to contamination by leaching.


#4.2 Final Selection

After preliminary selection of alternative landfill sites by Contractor, detailed and site specific geotechnical, hydrological, hydrogeological and environmental investigations shall be carried out which form the basis of the final selection of the most appropriate site. Final site location requires ESSO approval.

5.0 DESIGN AND CONSTRUCTION CRITERIA

5.1 Site Preparation and Access Roads

- 5.1.1 The area inside the operational-zone fence shall be cleared. Clearing shall include the removal of all trees, bushes, and other vegetation, to within 150 mm (6 in.) above the natural grade. It shall also include the removal of dense growths of ground cover, matted dead vegetation, and rubbish resting on natural grade. Clearing shall also include the specified removal of any existing structures, foundations, buried service piping and conduits.
- 5.1.2 Areas to be excavated or areas that will have facilities installed over them shall be grubbed. Grubbing shall include the excavation and complete removal of tree stumps, also the excavation and removal of all other plant life including root structures, plus rubbish, to a depth not less than 150 mm

ESSO EXPLORATION & PRODUCTION CHAD INC. 	SOLID WASTE LANDFILL	CCS 13-4-1 Page 6 of 27	
TECHNICAL SPECIFICATION		Rev. 0	11 Nov 96


(6 in) below natural grade. Other minimum grubbing depth criteria supplemental to the 150 mm (6 in) minimum depth below natural grade requirements for grubbing are as follows for the following specific Work areas:

- a. Drainage ditches shall be grubbed to a depth not less than 300 mm (1 ft) beneath the finished sides and bottom.
- b. Roadway areas shall be grubbed to a depth not less than 900 mm (3 ft) below finished grade but not less than 600 mm (2 ft) below natural grade.
- c. Embankment slopes shall be grubbed to a depth not less than 300 mm (1 ft) beneath the finished slope.
- d. Areas for piping between process unit areas limits and ditches, and along roads, shall be grubbed to a depth not less than 600 mm (2 ft) below finished grade but not less than 150 mm (6 in) below natural grade.

- 5.1.3** All organic material from clearing and grubbing, including trees, stumps, roots, and brush shall be managed and disposed as specified in CCS 21-20-108.
- 5.1.4** Topsoil shall be stripped and stockpiled as indicated in CCS-21-20-107 and CCS-21-20-108.
- 5.1.5** Erosion control measures shall be implemented in accordance with the construction drawings and CCS-21-20-107. Mitigation measures specified in CCS 21-20-107 shall be installed as soon as practical.

The faces of cut and fill slopes, and surface of soil subject to rain, wind, and runoff disturbance shall be protected against erosion unless they are not subject to erosion due to the erosion-resistant character of the material.

- 5.1.6** An all-weather, gravel access road with a laterite base shall be provided to the landfill site. As a minimum, the access road shall be designed and constructed in accordance with CCS 4-100-1
- 5.1.7** The landfill site shall be accessible only when operation personnel are on duty. A chain link fence and gates shall be designed and constructed around the entire site in accordance with CCS 4-11-1. Gates shall include provisions for locking.
- 5.1.8** A minimum 30 m (100 ft.) buffer zone is required between the perimeter fence and the landfill.

ESSO EXPLORATION & PRODUCTION CHAD INC. 	SOLID WASTE LANDFILL	CCS 13-4-1 Page 7 of 27	
TECHNICAL SPECIFICATION		Rev. 0	11 Nov 96

5.2 Perimeter Dike and Outer Storm Water Ditch

A perimeter dike shall enclose the proposed landfill site. The perimeter dike shall consist of a 6 meter (20 ft.) wide buffer zone including a 3 meter (10 ft.) fire lane and a perimeter ditch to manage the storm water run-on. The finished elevation of the dike shall be set with due consideration to the thickness of compacted clay cap over each landfill cell after it has been completely filled and closed.

5.3 Landfill Area and Excavation

***5.3.1** The total volume of wastes to be disposed during the life span of the landfill shall be based on the volume of acceptable solid waste generated by construction personnel and activities during construction as well as any volume requirements stated in the Design Basis Manual. Waste minimization shall be implemented, wherever feasible in order to keep the landfill area to an absolute minimum.

#5.3.2 All excavation material shall be processed and separated. Material meeting the grain size distribution indicated in Table 2 shall be retained and stockpiled for daily cover material. Those materials which are not needed for backfill or are unsuitable for daily cover shall be disposed of by the Contractor at a location approved by ESSO.


TABLE 2
Cover Material Gradation

SIEVE SIZE	PERCENT PASSING
12 mm (1/2 in.)	100
5 mm (No. 4)	90-100
2 mm (No. 10)	45-80
0.075 mm (No. 2000)	8-98
Clay (0.002 mm)	8-50

5.3.3 All excavations shall be kept free of standing water at all times. Dewatering equipment such as pumps and hoses shall be provided and operated by Contractor to remove water from excavated areas.


5.4 Side Slope of Landfill and Berm Sides

Safe side slopes shall be constructed. A slope stability analysis shall be performed for both excavated side slopes and above-ground embankments to verify the structural integrity of a cut slope or berm. The design configuration shall be evaluated for its stability under all potential hydraulic and loading conditions.

ESSO EXPLORATION & PRODUCTION CHAD INC. 	SOLID WASTE LANDFILL	CCS 13-4-1 Page 8 of 27	
TECHNICAL SPECIFICATION		Rev. 0	11 Nov 96

5.5 Liner Design and Construction

- 5.5.1 A non-hazardous landfill shall have 300mm (1 ft.) of protective soil over a leachate collection system which shall overlie a composite liner as defined in 5.5.3.
- 5.5.2 A hazardous landfill shall have 300mm (1 ft.) of protective soil over a leachate collection system which overlies a minimum 0.75 mm (30 mil.) Flexible Membrane Liner (FML). FML components consisting of High Density Polyethylene (HDPE) shall be at least 1.5 mm (60 mil) thick. The FML shall overlie a secondary leachate collection system. The secondary leachate collection system shall overlie a composite liner as defined in 5.5.3.
- 5.5.3 For purposes of this specification, "Composite Liner" means a system consisting of two components; the upper component must consist of a minimum 0.75 mm (30 mil) Flexible Membrane Liner (FML) and the lower component must consist of at least a 600 mm (2 ft) layer of compacted soil with a hydraulic conductivity of no more than 1×10^{-7} cm/sec (3.94×10^{-8} in/sec). FML components consisting of High Density Polyethylene (HDPE) shall be at least 1.5 mm (60 mil) thick. The FML component must be installed in direct and uniform contact with the compacted soil component. The panel layout plan shall be made in advance so that travel of heavy equipment on the liner can be avoided. Vehicles shall not be allowed on completed liners. Seaming of panels shall be completed in accordance with manufacturer's recommendations.
- 5.5.4 If groundwater is encountered in disposal excavations, or in cases where excavations extend below the seasonal high-water table, material with a weight equivalent to 300 mm (1 ft.) of compacted clay liner for every 600 mm (2 ft.) of static water head shall be used as a basis for the construction of a liner between the deposited solid waste and the groundwater. The total thickness of this liner shall consist of no less than 900 mm (3 ft.) of soil with a permeability coefficient of no more than 1×10^{-7} cm/sec (3.94×10^{-8} in/sec), a liquid limit of no less than 30, a plasticity index of no less than 15, and a percent passing Number 200 sieve of no less than 30. Pressure release systems may be used to reduce the amount of liner support required.
- 5.5.5 The subgrade for placement of the clay portion of the composite liner shall be compacted in accordance with the following standards:
- a. Cohesive soils - 95 percent of the Modified Maximum Proctor Dry Density (MMPDD) in accordance with ASTM D1557.
 - b. Non-cohesive soils - 80 percent of relative density per ASTM D4253 and ASTM D4254.

ESSO EXPLORATION & PRODUCTION CHAD INC. 	SOLID WASTE LANDFILL	CCS 13-4-1 Page 9 of 27	
TECHNICAL SPECIFICATION		Rev. 0	11 Nov 96

5.5.6 Material for the clay portion of the composite liner shall be uniform with clods, rocks, and stones no larger than 25 mm (1 in.) and that total no more than 10% by weight. Disking and tilling of the material shall be performed as required to break up large clods. In all cases, soil clods shall be reduced to the smallest size necessary to achieve the coefficient of permeability reported by the testing laboratory and to destroy any macrostructure evidenced after the compaction of the clods under density-controlled conditions. Rock content shall not be a detriment to the integrity of the overlaying geomembrane.

5.5.7 The liner soil material shall be placed in lifts not exceeding 150 mm (6 in.). The surface of the previous lift shall be scarified before the next layer is added. Liner soil material shall not be compacted with a bulldozer or any track-mobilized equipment unless it is used to pull a pad-footed or prong-footed roller. Each new lift shall be fully compacted to the previous lift to form a monolithic unit. The liner soil material shall be compacted to 97% of the MMPDD according to ASTM D1557.

#5.5.8 Unless Alternate construction procedures are approved in writing by ESSO, all constructed liners shall be keyed into an underlying formation of sufficient strength to ensure stability of the constructed lining.

5.6 High Permeability Sand Layer for Drainage

A highly permeable sand layer shall be placed over the composite liner. The thickness of the layer shall be such that it provides a maximum of 300 mm (12 in.) of leachate head above the liner. The sand drainage layer shall have a minimum slope of 2%. The drainage layer serves two functions:


- a. Drain the leachate away from the underside of the waste.
- b. Protect the composite liner.

5.7 Leachate Collection System

5.7.1 The leachate collection system shall be designed to maintain less than 300 mm (12 in.) depth of leachate or "head" above the liner during the operating life of the landfill and through the closure and post closure periods.

5.7.2 The leachate collection and removal systems shall be:

- a. constructed of materials that are chemically resistant to the leachate expected to be generated,
- b. built of sufficient strength and thickness to prevent collapse under the pressures exerted by overlaying wastes, waste cover materials, and by any equipment at the landfill; and
- c. designed and operated to function through the scheduled closure period of the solid waste landfill.

ESSO EXPLORATION & PRODUCTION CHAD INC. 	SOLID WASTE LANDFILL	CCS 13-4-1 Page 10 of 27	
TECHNICAL SPECIFICATION		Rev. 0	11 Nov 96

5.7.3 The leachate collection system shall consist of a number of perforated pipes (as per ASTM D3034, if the criteria of 5.7.2 are satisfied), with protective filter wrapping material, laid into the sand drainage layer.


5.7.4 The leachate collection system shall be designed and installed with the following characteristics:

- a. A trench shall be provided for the perforated pipes with 150 mm (6 in.) depth of cover of sand over the pipe.
- b. The drain pipes shall have not less than 2% slope.
- c. Size and horizontal spacing of the drain pipes shall be sufficient to control leachate levels to within the limits specified above.
- d. The perforated pipe shall be wrapped in a woven polyethylene fabric such as Nicolon #66339, manufactured by Nicolon B.V., or equal as approved by ESSO.
- e. Leachate collection lines that penetrate the liner shall have an antiseep collar. A minimum of 1.5m (5 ft.) of compacted clay shall be placed around the collar in all directions.
- f. Pipe materials shall be clean and free of defects when placed in trench. The Contractor shall not allow heavy equipment to travel over the newly installed leachate pipe during construction.
- g. Collection sumps shall be provided to capture leachates for treatment. Separate sumps shall be provided for hazardous and non-hazardous landfills. Separate sumps shall be provided for primary and secondary leachate collection systems in the hazardous landfill
- h. Collection sumps shall be sized to collect the maximum volume of leachate expected during a leachate monitoring period specified in the "Operating Procedures" Section 6.0 of this specification.
- i. The collection sump shall be a water-tight concrete structure with a water-tight, chemical-resistant liner. The design and construction of the collection sump shall be in accordance with CCS 4-10-1.

5.8 Run-On and Run-Off Control

5.8.1 Run-on control prevents rain water from flowing into the active portion of the landfill. Run-on control structures such as ditches, dikes and culverts shall be capable of preventing flow on to the active portion of the landfill during peak discharge from at least a 25 year storm.

5.8.2 Run-off control is the management of precipitation which falls on the landfill site so as to minimize the amount of rain water that gets in contact with waste or leachate. The run-off management system shall collect and control at least the water volume resulting from a 24-hour, 25-year storm. This shall be achieved in either of two ways:

ESSO EXPLORATION & PRODUCTION CHAD INC. 	SOLID WASTE LANDFILL	CCS 13-4-1 Page 11 of 27	
TECHNICAL SPECIFICATION		Rev. 0	11 Nov 96

- a. Keeping the active landfill cells small and by providing adequate grading so that run-off is controlled and diverted away from the working area.
- b. Collecting and discharging run-off from the inactive portion of the landfill as storm water, thus reducing the overall leachate volume to be treated.

5.8.3 For erosion control, up-gradient and down-gradient ditches, berms, rip rap, pavements or combinations thereof shall be used as necessary to achieve run-off and run-on control.

5.8.4 Collection and holding facilities (e.g., sumps or basins) associated with run-on or run-off control system must be emptied or otherwise managed expeditiously after storms to maintain design capacity of the system.

5.9 Preparation of Landfill Cells

One landfill cell of each landfill type (hazardous and non-hazardous) shall be opened at a time. The bottom of each cell shall be sloped for drainage away from the waste material. A temporary berm of approximately 0.6m to 0.9m (2 ft. to 3 ft.) in width shall be installed for isolation from previous cells.

5.10 Gas Venting System


A minimum of one passive gas vent shall be provided per cell to prevent the build-up of gas pressure beneath the cover.

#5.11 Soils and Liner Quality Control Plan

Before landfill construction begins, Contractor shall have an ESSO approved Soils and Liner Quality Control Plan (SLQCP). The SLQCP must be included in the Site Development Plan to provide operating personnel adequate procedural guidance for assuring continuous compliance with groundwater protection requirements. The plan shall specify construction methods employing good engineering practices for compaction of clay soils to form a liner as well as the installation and testing of an FML. Quality control testing and reporting shall also be discussed.

The SLQCP shall include the following information:


- a. Proposed dewatering plans, where applicable.
- b. Constructed liner details, where applicable shall be depicted on cross-sections of a typical trench showing the slope, widths, and thickness for compaction lifts. The amount of compaction shall be expressed as a percentage of a predetermined laboratory density.
- c. Soil and liner quality control testing procedures, including sampling frequency. All field sampling and testing, both during construction and after completion, shall be performed by the Contractor acting in compliance with the provisions of local government regulations and project environmental and quality control standards.

ESSO EXPLORATION & PRODUCTION CHAD INC. 	SOLID WASTE LANDFILL	CCS 13-4-1 Page 12 of 27	
TECHNICAL SPECIFICATION		Rev. 0	11 Nov 96

5.12 Soil and Liner Testing

Soil liner quality control testing frequencies and procedures shall be in accordance with the following:

- 5.12.1 All field sampling and testing, both during construction and after completion of the lining, shall be performed by a qualified professional experienced in geotechnical engineering and/or engineering geology, or under his direct supervision.
- 5.12.2 All liners shall have continuous on-site inspection during construction by the Contractor.
- 5.12.3 Clay liners density shall be expressed as a percentage of a maximum dry density based on a compaction test. The clay liner, after compaction, shall be proven by soils laboratory testing to provide a coefficient of permeability of 1×10^{-7} cm/sec (3.94×10^{-8} in/sec) or less.
- #5.12.4 The SLQCP shall define the frequency of testing for coefficient of permeability, sieve analysis, Atterberg limits, density, moisture content and thickness verification. These frequencies shall be expressed in numbers of tests per specific area of liner per lift or specific thickness of liner, unless an alternate frequency is approved by ESSO.
- #5.12.5 Unless otherwise approved by ESSO, all soil tests performed on any in-situ or constructed soil liners shall be in accordance with the following standards:
 - a. Laboratory permeability tests shall be run using tap water or 0.05N solution of CaSO_4 and not distilled water. All test data must be submitted on permeability tests regardless of test method used. At a minimum, the calculations of the last data set reported for each sample and the resultant coefficient of permeability shall be reported as supporting data. Tests shall be either constant head with back pressure (Appendix VII of EM 1110-2-1906; or ASTM D5084) or falling head (Appendix VII of EM 1110-2-1906).
 - b. Sieve analysis with +1,200, to -200 sieves (ASTM D422 or ASTM D1140, as applicable).
 - c. Atterberg limits (ASTM D4318).
 - d. Moisture-density relations (ASTM D1557).
 - e. Moisture content (ASTM D2216).
- 5.12.6 All soils used as constructed liners shall have the following minimum values verified by testing in a soils laboratory:
 - a. plasticity index equal to or greater than 30;

ESSO EXPLORATION & PRODUCTION CHAD INC. 	SOLID WASTE LANDFILL	CCS 13-4-1 Page 13 of 27	
TECHNICAL SPECIFICATION		Rev. 0	11 Nov 96

- b. percent passing 200 mesh sieve (-200) equal to or greater than 30%;
- c. percent passing 25mm (1 in.) screen equal to 100%;
- d. coefficient of permeability less than or equal to 1×10^{-7} cm/sec (3.94×10^{-8} in/sec.).

#5.12.7 Permeability tests for providing the suitability of soils to be used in constructing clay liners shall be performed in the laboratory using the procedures and guidance of 5.12.5(a). Field quality control must be provided by field density tests based on predetermined moisture-density compaction curves, Atterberg limits, and laboratory permeabilities of undisturbed field samples of compacted liner soils, unless an alternate plan is approved by ESSO.

#5.12.8 Field permeability testing of in situ soils or constructed soil liners shall be in accordance with ASTM D5093 for those soil liners which are in the floor of the excavation and a suitable variation approved by ESSO for the sidewalls.


5.12.9 Soil and liner density shall be expressed as a percentage of the maximum dry density and at the corresponding optimum moisture content specified as appropriate by an engineer experienced in geotechnical engineering. These soils, after compaction, shall upon testing either in the laboratory or as a test pad in the field demonstrate a coefficient of permeability no greater than 1×10^{-7} cm/sec (3.94×10^{-8} in/sec.).

5.12.10 All quality control testing of soil liners shall be performed during the construction of the liner. In no instance shall any quality control field or laboratory testing be undertaken after completion of liner construction, except for that testing which is required of the final constructed lift, confirmation of liner thickness, or cover material thickness.

5.12.11 All soil testing and evaluation of either in situ soil or constructed soil liners shall be complete prior to installing the leachate collection system.

5.13 Soils and Liner Evaluation Report (SLER) and Flexible Membrane Liner Evaluation Report (FMLER)

#5.13.1 Prior to the disposal of solid waste in any trench, or on any area, excavation, or unprotected surface, a SLER and a FMLER shall be prepared by Contractor and submitted to ESSO for approval. Each SLER shall be prepared in accordance with the approved SLQCP. Any deviation from an approved SLQCP shall have prior written approval from ESSO. The SLER and FMLER shall report and summarize the results of tests performed to satisfy the requirements of the SLQCP. Any deficiencies found and remedial actions taken to bring the liners into compliance shall be noted.

ESSO EXPLORATION & PRODUCTION CHAD INC. 	SOLID WASTE LANDFILL	CCS 13-4-1 Page 14 of 27	
TECHNICAL SPECIFICATION		Rev. 0	11 Nov 96

#5.13.2 Markers shall be placed on site at the landfill facility so that all disposal areas for which a SLER has been submitted and approved by ESSO are readily determinable. Such markers are to provide site workers immediate knowledge at all times of the extent of approved disposal areas. These markers shall be located so that they are not destroyed during operations.

#5.13.3 Contractor shall provided sufficient documentation to ESSO to assure that the potential for contamination of waters is minimized. If ESSO determines that the SLER is incomplete or that the test data provided are insufficient to support the evaluation conclusions, additional test data or other information may be required, and use of the trench or disposal area shall not be allowed until such additional data are received, reviewed, and approved. Each SLER shall be signed by the Contractor.


5.13.4 The surface of a constructed soil liner should be covered with a layer of solid waste within a period of six months to mitigate the effects of surface erosion and rutting due to traffic. Liner surfaces not covered with waste within six months shall be checked by the Contractor, who shall then submit a letter report on its findings to ESSO. Any required repairs shall be performed promptly. A new SLER shall be submitted on the new construction for all liners that need repair due to damage.

#5.14 Groundwater Monitoring Systems

A groundwater monitoring system shall be installed that consists of a sufficient number of monitoring wells, installed at appropriate locations and depths, to yield representative groundwater samples from the uppermost aquifer, defined as the geologic formation nearest the natural ground surface that is an aquifer. This includes lower aquifers that are hydraulically interconnected with this aquifer within the facility's property boundary.

The design of the groundwater monitoring system, including the number, spacing, and depths of monitoring wells or other sampling points, shall be certified by a qualified groundwater scientist. The design shall be based on site specific technical information that must include a thorough characterization of:

- a. aquifer thickness;
- b. groundwater flow rate;
- c. groundwater flow direction including seasonal and temporal fluctuation in flow, effect of site construction and operations on groundwater flow direction and rates;
- d. and thickness, stratigraphy, lithology, and hydraulic characteristics of saturated and unsaturated geologic, and fill material overlying the uppermost aquifer, materials of the uppermost aquifer, and materials of the lower confining unit of

ESSO EXPLORATION & PRODUCTION CHAD INC. 	SOLID WASTE LANDFILL	CCS 13-4-1 Page 15 of 27	
TECHNICAL SPECIFICATION		Rev. 0	11 Nov 96

the uppermost aquifer. A geologic unit is any distinct or definable native rock or soil stratum.

Background wells shall be installed to allow determination of the quality of background groundwater that has not been affected by leakage from a unit. A determination of background quality may include sampling of wells that are not hydraulically upgradient of the waste management area if hydrogeologic conditions do not allow the Contractor to determine which wells are hydraulically upgradient. Alternatively, sampling at other wells can be performed if it will provide a better indication of background groundwater quality than is possible from upgradient wells. The downgradient monitoring system shall include monitoring wells installed to allow determination of the quality of groundwater passing the relevant point of compliance. The point of compliance is defined as the vertical surface located no more than 500 feet from the hydraulically downgradient limit of the waste management unit boundary, extending down through the uppermost aquifer underlying the landfill area, and located on land owned by ESSO. The final design of the groundwater monitoring system shall be submitted to ESSO for approval.

The downgradient monitoring system shall be installed to ensure the detection of groundwater contamination in the uppermost aquifer.

5.15 Monitoring Wells


Monitoring well installation and development shall be supervised by a qualified geologist or engineer.

#5.15.1 Drilling

Monitoring wells shall be drilled by a method that shall allow installation of the casing, screen, etc., and that shall not introduce contaminants into the borehole or casing. Drilling techniques used for boring shall take into account the materials to be drilled, depth to groundwater, total depth of the hole, adequate soil sampling, and other such factors that affect the selection of the drilling method. If any fluids are necessary in drilling or installation, then clean, treated water shall be used. Other fluids shall be approved in writing by ESSO before use. Chemical analysis of the water used shall be provided to ESSO with the monitoring well report.

The diameter of the boring shall be at least 100 mm (4 in.) larger than the diameter of the casing. When the boring is in hard rock, a smaller annulus may be submitted to ESSO for approval.

During drilling of the monitoring well, a log of the boring shall be made by a qualified geologist or engineer.

ESSO EXPLORATION & PRODUCTION CHAD INC. 	SOLID WASTE LANDFILL	CCS 13-4-1 Page 16 of 27	
TECHNICAL SPECIFICATION		Rev. 0	11 Nov 96

#5.15.2 Casing


The well casing shall be: 50 to 100 mm (2 to 4 in.) in diameter, NSF-certified PVC schedule 40 or 80 pipe, flush-thread, screw joint (no glue or solvents); polytetrafluoroethylene (PTFE, such as Teflon) tape or O-rings in the joints; no collar couplings. The top of the casing shall be at least 600 mm (2 ft.) above ground level. Where high levels of volatile organic compounds (VOC's) or corrosive compounds are anticipated, stainless steel or PTFE casing and screen may be used, subject to approval by ESSO. 100 mm (4 in.) diameter casing is recommended because it allows larger volume samples to be obtained and provides easier access for development, pumps, and repairs. The casing shall be cleaned and packaged at the place of manufacture; the packaging shall include a PVC wrapping on each section of casing to keep it from being contaminated prior to installation. The casing shall be free of ink, labels, or other markings. The casing (and screen) shall be centered in the hole to allow installation of a good filter pack and annular seal, using appropriately placed centralizers. The top of the casing shall be protected by a threaded or slip-on top cap or by a sealing cap or screw-plug seal inserted into the top of the casing. The cap shall be vented to prevent buildup of methane or other gases.

5.15.3 Well Screen

The screen shall be compatible with the casing and shall be of the same material. The screen shall not involve the use of any glues or solvents for construction. A wire-wound screen is recommended to provide maximum inflow area. Field-cut slots are not permitted for well screen. Filter cloth shall not be used. A blank-pipe sediment trap, typically 300 to 600 mm (1 to 2 ft.) shall be installed below the screen. A bottom cap shall be placed on the bottom of the sediment trap. The sediment trap shall not extend through the lower confining layer of the water-bearing zone being treated. Screen sterilization methods are the same as those for casing. Selection of the size of the screen opening shall be performed by a person experienced with such work and shall include consideration of the distribution of particle sizes both in the water-bearing zone and in the filter pack surrounding the screen. The screen opening shall not be larger than the smallest fraction of the filter pack.

5.15.4 Filter Pack

The filter pack, placed between the screen and the well bore, shall consist of pre-packaged, inert, clean, silica sand or glass beads; it shall extend from 300mm to 1200mm (1 ft. to 4 ft.) above the top of the screen. Open stockpile sources of sand or gravel are not permitted. The filter pack usually has a 30% finer grain size that is about 4 to 10 times larger than the 30% finer grain size of the water-bearing zone; the filter pack shall have

ESSO EXPLORATION & PRODUCTION CHAD INC. 	SOLID WASTE LANDFILL	CCS 13-4-1 Page 17 of 27	
TECHNICAL SPECIFICATION		Rev. 0	11 Nov 96

a uniformity coefficient less than 2.5. The filter pack shall be placed with a tremie pipe to ensure that the material completely surrounds the screen and casing without bridging. The tremie pipe shall be cleaned prior to installing the first well and before each subsequent well.


5.15.5 Seals

The annular seal shall be placed on top of the filter pack and shall be at least 600 mm (2 ft.) thick. It shall be placed in the zone of saturation to maintain hydration. The seal shall be composed of, in order of preference, coarse-grain sodium bentonite, coarse-grit sodium bentonite, or bentonite grout. Special care shall be taken to ensure that fine material or grout does not plug the underlying filter pack. Placement of a few inches of pre-packaged clean fire sand on top of the filter pack shall be used to prevent migration of the annular seal material into the filter pack. The seal shall be placed on top of the filter pack with a clean tremie pipe to ensure good distribution and shall be tamped with a clean rod to determine that the seal is thick enough. The bentonite shall be hydrated with clean water prior to any further activities on the well and left to stand until hydration is complete (8 to 12 hours, depending on the grain size of the bentonite). If a bentonite-grout (without cement) casing seal is used in the well bore, then it may replace the annular seal.

A casing seal shall be placed on top of the annular seal to prevent fluids and contaminants from entering the borehole from the surface. The casing seal shall consist of a commercial bentonite grout or a cement-bentonite mixture. Drilling spoil, cutting, or other native materials are not permitted for use as a casing seal. Quick-setting cements are not permitted for use because contaminants may leach from them into the groundwater. The top of the casing seal shall be between 1500 mm and 600 mm (5 ft. and 2 ft.) from the surface.

5.15.6 Concrete Pad

Concrete, with a compressive strength of 25 Mpa (3625 psi), shall be placed from the top of the casing seal (600 to 1500 mm (2 to 5 ft.) below the surface) continuously to the top of the ground to form a pad at the surface. This formed surface pad shall be at least 150 mm (6 in.) thick and not less than 1200 mm (4 ft.) square or 1500 mm (5 ft.) in diameter. The pad shall contain sufficient reinforcing steel to ensure its structural integrity in the event that soil support is lost. The top of the pad shall slope away from the well bore to the edges to prevent ponding of water around the casing or collar.

ESSO EXPLORATION & PRODUCTION CHAD INC. 	SOLID WASTE LANDFILL	CCS 13-4-1 Page 18 of 27	
TECHNICAL SPECIFICATION		Rev. 0	11 Nov 96

5.15.7 Protective Collar

A steel protective pipe collar shall be placed around the casing "stickup" to protect it from damage and unwanted entry. The collar shall be set at least 300 mm (1 ft.) into the surface pad during its construction and should extend at least 75 mm (3 in.) above the top of the well casing (and top cap, if present). The top of the collar shall have a lockable hinged top flap or cover. A sturdy lock shall be installed, maintained in working order, and kept locked when the well is not being bailed/purged or sampled. The well number or other designation shall be marked permanently on the collar, including the total depth of the well and its elevation on the collar.

#5.15.8 Protective Barrier

Where monitoring wells are likely to be damaged by moving equipment or are located in heavily traveled areas, a protective barrier shall be installed. A typical barrier is three or four 150 mm (6 in.) to 300 mm (12 in.) diameter pipes set in concrete just off the protective pad. The pipes can be joined by pipes welded between them, but consideration must be given to well access for sampling and other activities. Separation of such a pipe barrier from the pad means that the barrier can be damaged without risk to the pad and well. Other types of barriers may be approved by ESSO.

#5.15.9 Unusual Conditions


Where monitoring wells are installed in unusual conditions, all aspects of the installation shall be submitted to ESSO in writing in advance for their consideration. Such aspects include, for example, the use of cellar-type enclosures for the top-well equipment or multiple completions in a single hole.

5.15.10 Well Development

After a monitoring well is installed, it shall be developed to remove artifacts of drilling (clay films, bentonite pellets in the casing, etc.) and to open the water-bearing zone for a maximum flow into the well. Development should continue until all of the water used or affected during drilling activities has been removed and field measurements of pH, specific conductance, and temperature have stabilized. Failure to develop a well properly may mean that it is not properly monitoring the water-bearing zone or may not yield adequate water for sampling even though the water-bearing zone is prolific.

5.15.11 Location and Elevation

Upon completion of a monitoring well, the location of the well and all appropriate elevations associated with the top-well equipment shall be surveyed. The elevation shall be surveyed to the nearest 0.003 m (0.01 ft.)

ESSO EXPLORATION & PRODUCTION CHAD INC. 	SOLID WASTE LANDFILL	CCS 13-4-1 Page 19 of 27	
TECHNICAL SPECIFICATION		Rev. 0	11 Nov 96

above mean sea level (with year of the sea-level datum shown). The point on the well casing for which the elevation was determined shall be permanently marked on the casing. The location shall be given in terms of the latitude and longitude at least to the nearest tenth of the second or shall be accurately located with respect to the landfill grid system.

5.15.12 Reporting

Monitoring well installation and construction details shall be completed and submitted to ESSO within 30 days of well completion. A copy of the detailed geologic log of the boring, any particle size or other sample data from the well, and a site map drawn to scale showing the location of all monitoring wells shall be submitted to ESSO.

*5.15.13 Damaged Wells

Any monitoring well that is damaged to the extent that it is no longer suitable for sampling shall be reported to ESSO who shall make a determination about whether to repair or replace the well.

#5.15.14 Plugging and Abandonment

Any monitoring well that is no longer used shall be properly plugged and abandoned. No abandonment shall take place without prior authorization in writing by ESSO. Procedures for abandonment shall be as given in CCS 11-10-1.


6.0 OPERATING PROCEDURES

The landfill operation performed by Contractor, shall consist of placing, spreading and compacting solid waste materials approved for landfill disposal in Contractor's Waste Management Plan in landfill cell trenches in uniform layers separated by layers of cover material. After construction activities have been completed, the landfill cells used during the pre-operations phase will be capped and closed. The landfill site will remain open and will continue to serve as the disposal area for solid wastes generated by the fixed facilities personnel during operations.

6.1 Health and Safety

The disposal site shall be operated in such a manner as to protect the health and safety of personnel associated with the operation. The Contractor shall instruct personnel as to standard procedures for maintaining safety in accordance with GPS-008 and Section 22 of the Coordination Procedures. In addition, the following measures shall be implemented:

- a. Personal safety devices and gear shall be provided by the Contractor to facility personnel.

ESSO EXPLORATION & PRODUCTION CHAD INC. 	SOLID WASTE LANDFILL	CCS 13-4-1 Page 20 of 27	
TECHNICAL SPECIFICATION		Rev. 0	11 Nov 96

- b. Safety and warning devices shall be provided on all equipment used to spread and compact waste or cover material.
- c. The Contractor shall take appropriate steps to prevent and control on site populations of disease vectors using proper compaction and daily cover procedures, and the use of other approved methods as needed.
- d. Litter and other windblown material shall be collected on a regular basis and returned to the active disposal area or working face as necessary to minimize unhealthy, unsafe, or unsightly conditions.
- e. The working surfaces of all equipment that come in contact with wastes shall be washed down on a regular basis. Wastewaters shall not be allowed to accumulate on site without proper treatment to prevent the creation of odors or an attraction to disease vectors.
- f. The Contractor shall make provisions to extinguish any fires in wastes being delivered to the site or which occur at the working face or within equipment or personnel facilities.

6.2 Placement of Solid Waste Material

Waste materials shall be trucked to the landfill and placed in the appropriate landfill cell trenches (based on waste type). The waste shall be compacted on slopes less than 3:1 (H:V) in lifts of 600mm (2 ft.) or less by three to five passes of tracked equipment. Solid waste handling equipment shall on any operating day be capable of performing the following functions:

- a. Spreading the waste materials in an uncompacted layer with a maximum thickness of 600mm while confining it to the smallest practicable area,
- b. Compacting the spread waste material to the smallest practicable volume, and
- c. Placing, spreading and compacting the cover material over a waste layer by the end of the day's operation.

6.3 Daily and Intermediate Cover

Soil cover shall be placed to control insects, rodents, scavenging by birds, blowing litter, flies, odors and to provide better access to the working face. The intent is to ensure that deposition of waste will not adversely affect the environment or public health.

A soil cover (minimum 150 mm (6 in.) thickness) shall be placed and compacted daily. Acceptable cover material shall meet the criteria given in Table 2.

An intermediate soil cover (minimum 300 mm (12 in.) thickness) shall be placed and compacted on areas which will not receive additional wastes for longer periods.

The cover material for each layer of waste shall be spread and compacted in accordance with Table 3.


ESSO EXPLORATION & PRODUCTION CHAD INC. 	SOLID WASTE LANDFILL	CCS 13-4-1 Page 21 of 27	
TECHNICAL SPECIFICATION		Rev. 0	11 Nov 96

TABLE 3
Depth of Cover Material

TYPE OF COVER [Period of Site Inactivity (P)]	DAILY [P < 1 week]	INTERMEDIATE [week < P < 1 year]	FINAL [P > 1 year]
Compacted Thickness	150 mm	300 mm	600 mm

6.4 Leachate Collection and Disposal

The leachate sumps shall be monitored by Contractor for level of accumulated liquid and leachate quality. Sumps shall be monitored on a regular basis to ensure that overflowing does not occur. The leachate quality shall be monitored semi-annually. The leachate shall be extracted from the sumps and disposed of by the Contractor in its sewage treatment plant. If necessary, Contractor shall adjust leachate pH and treat to remove heavy metals and excess salts that would not be compatible with the sewage treatment design parameters and effluent quality before sending the leachate to its sewage treatment system.

The leachate collection system must be properly maintained on an annual basis (or more often, as necessary). The leachate lines shall be cleaned out by the Contractor and the sump pump inspected once a year.

6.5 Groundwater Monitoring


The groundwater monitoring program shall include consistent sampling and analysis procedures that are designed to ensure monitoring results that provide an accurate representation of groundwater quality at the background and downgradient wells.

The Contractor shall notify ESSO promptly (within 1 day) in writing of changes in site construction or operation or changes in adjacent property that affect or are likely to affect the direction and rate of groundwater flow and the potential for detecting groundwater contamination from the solid waste landfill that may require the installation of additional monitoring wells or sampling points.

#6.5.1 Groundwater Sampling and Analysis Plan

Contractor shall submit a groundwater sampling and analysis plan (GWSAP) to ESSO for review and approval prior to commencement of sampling and shall maintain a current copy in the operating record. The GWSAP shall:

- a. include procedures and techniques for sample collection, sample preservation and shipment, analytical procedures, chain-of-custody controls, quality assurance, and quality control;
- b. provide for measurement of groundwater elevations at each sampling point prior to bailing or purging. Measurement at an event shall be

ESSO EXPLORATION & PRODUCTION CHAD INC. 	SOLID WASTE LANDFILL	CCS 13-4-1 Page 22 of 27	
TECHNICAL SPECIFICATION		Rev. 0	11 Nov 96

accomplished over a period of time short enough to avoid temporal variations in water levels. Sampling at each event shall proceed from the point with the highest water-level elevation to those with successively lower elevations unless contamination is known to be present, in which case wells not likely to be contaminated shall be sampled prior to those that are known to be contaminated unless an alternative procedure is approved by ESSO; and

- c. include sampling and analytical methods that are appropriate for groundwater sampling and that accurately measure hazardous constituents and other monitoring parameters in groundwater samples. The number of samples to be collected to establish groundwater quality data shall be consistent with the appropriate statistical procedures for determination of evidence of contamination.

6.5.2 Groundwater Sampling and Analysis

Groundwater samples shall not be field-filtered prior to laboratory analysis.

The sampling procedures shall be protective of human health and the environment and appropriate for generation of statistically significant data.


Contractor shall establish background groundwater quality in hydraulically upgradient wells or in background wells for each of the monitoring parameters or constituents required in the ground monitoring program for a solid waste landfill. Downgradient groundwater data shall not be adjusted by subtracting background groundwater data.

The Contractor shall determine within 7 calendar days after completing sampling and analysis whether or not there is evidence of a statistically significant change from background values for each constituent required in the groundwater monitoring program for the solid waste landfill. In determining if there is evidence of a statistically significant change from background, the Contractor shall compare the groundwater quality of each tested constituent at each monitoring well or other sampling points to the background value of that constituent.

*6.5.3 Constituents to be Monitored

Compounds that groundwater samples shall be tested for include those listed in Table 4, at a minimum. ESSO may delete any of the constituents listed in Table 4 if it can be documented that the removed constituents are not reasonably expected to be in or derived from the waste contained in the landfill. Contractor may also petition ESSO for removal of constituents from the list if it believes these conditions are met.

Parameters shall be tested using methods in Standard Methods for the Examination of Water and Wastewater (Mary Ann H. Franson, editor,

ESSO EXPLORATION & PRODUCTION CHAD INC. 	SOLID WASTE LANDFILL	CCS 13-4-1 Page 23 of 27	
TECHNICAL SPECIFICATION		Rev. 0	11 Nov 96


American Public Health Association, 1995). Test results shall be certified by Contractor and the records of said tests kept as per Section 30 of the Coordination Procedure.

ESSO may establish an alternative list of inorganic indicator constituents in lieu of some or all of the heavy metals if the alternative constituents provide a reliable indication of inorganic releases from the solid waste landfill to the groundwater.

ESSO may also add inorganic or organic constituents to those to be tested if they are reasonably expected to be in or derived from the waste contained in the unit or if they are likely to provide a useful indication of releases from the solid waste landfill to the groundwater.


TABLE 4
Sample Analysis Parameters

	INORGANIC CONSTITUENTS	CAS RN ^{1,2}
1	Antimony	(Total)
2	Arsenic	(Total)
3	Barium	(Total)
4	Beryllium	(Total)
5	Cadmium	(Total)
6	Chromium	(Total)
7	Cobalt	(Total)
8	Copper	(Total)
9	Lead	(Total)
10	Mercury	(Total)
11	Nickel	(Total)
12	Selenium	(Total)
13	Silver	(Total)
14	Thallium	(Total)
15	Vanadium	(Total)
16	Zinc	(Total)
	ORGANIC CONSTITUENTS³	
17	Acetone	67-64-1
18	Acrylonitrile	107-13-1
19	Benzene	71-43-2
20	Bromochloromethane	74-97-5
21	Bromodichloromethane	75-27-4
22	Bromoform (tribromomethane)	75-25-2
23	Carbon disulfide	75-15-0
24	Carbon tetrachloride	56-23-5
25	Chlorobenzene	108-90-7
26	Chloroethane (ethyl chloride)	75-00-3

ESSO EXPLORATION & PRODUCTION CHAD INC. 	SOLID WASTE LANDFILL	CCS 13-4-1 Page 24 of 27	
TECHNICAL SPECIFICATION		Rev. 0	11 Nov 96

27	Chlorform (trichloromethane)	67-66-3
28	Dibromochloromethane (chlorodibromomethane)	124-48-1
29	1,2-Dibromo-3-chloropropane (DBCP)	96-12-8
30	1,2-Dibromoethane (ethylene dibromide, EDB)	106-93-4
31	o-Dichlorobenzene (1,2-dichlorobenzene)	95-50-1
32	p-Dichlorobenzene (1,4-dichlorobenzene)	106-46-7
33	trans-1,4-Dichloro-2-butene	110-57-6
34	1,1-Dichloroethane (ethylidene chloride)	75-34-3
35	1,2-Dichloroethane (ethylene dichloride)	107-06-2
36	1,1-Dichloroethylene (1,1-dichloroethene, vinylidene chloride)	75-35-4
37	cis-1,2-Dichloroethylene (cis-1,2- dichloroethene)	156-59-2
38	trans-1,2-Dichloroethylene (trans 1,2- dichloroethene)	156-60-5
39	1,2-Dichloropropane (Propylene dichloride)	78-87-5
40	cis-1,3-Dichloropropane	10061-01-5
41	trans-1,3-Dichloropropene	10061-02-6
42	Ethylbenzene	100-41-4
43	2-Hexanone (methyl butyl ketone)	591-78-6
44	Methyl bromide (bromomethane)	74-83-9
45	Methyl chloride (chloromethane)	74-87-3
46	Methylene bromide (dibromomethane)	74-95-3
47	Methylene chloride (dichloromethane)	75-09-2
48	Methyl ethyl ketone (MEK, 2-butanone)	78-93-3
49	Methyl iodide (iodomethane)	74-88-4
50	4-Methyl-2-pentanone (methyl isobutyl ketone)	108-10-1
51	Styrene	100-42-5
52	1,1,1,2-Tetrachloroethane	630-20-6
53	1,1,2,2-Tetrachloroethane	79-34-5
54	Tetrachloroethylene (tetrachloroethene, perchloroethylene)	127-18-4
55	Toluene	108-88-3
56	1,1,1-Trichloroethane (methychloroform)	71-55-6
57	1,1,2-Trichloroethane	79-00-5
58	Trichloroethylene (trichloroethene)	79-01-6
59	Trichlorofluoromethane (CFC-11)	75-69-4
60	1,2,3-Trichloropropane	96-18-4
61	Vinyl acetate	108-05-4
62	Vinyl chloride	75-01-4
63	Xylenes	1330-20-7

¹ The Chemical Abstracts Service registry number (CAS RN).

ESSO EXPLORATION & PRODUCTION CHAD INC. 	SOLID WASTE LANDFILL	CCS 13-4-1 Page 25 of 27	
TECHNICAL SPECIFICATION		Rev. 0	11 Nov 96

2. Where "Total" is entered, all species in the groundwater that contain the element are included.
3. Common names of the volatile organic compounds are those widely used in government regulation, scientific publications and commerce; synonyms exist for many of them.

6.5.4 Monitoring Frequency

The monitoring frequency for all constituents shall be annually during the active life of the facility and the closure period.

A minimum of four statistically independent samples from each background and each downgradient well shall be collected and analyzed for the constituents. The independence of the four samples shall be achieved by bailing or purging at least three well volumes (or to dryness, if less) from each well before each of the four samples is collected.


ESSO may specify an appropriate alternative frequency for repeated sampling and analysis of the constituents. The alternative frequency shall be no less than annual and shall be based on factors such as lithology and hydraulic conductivity of the aquifer and unsaturated zone, groundwater flow rates, minimum distance of travel from waste to monitoring wells, and resource value of the uppermost aquifer.

#6.5.5 Changes in Groundwater Quality

Not later than 60 days after each sampling event, Contractor shall notify ESSO in writing if there has been a statistically significant change from background of any tested constituent at any monitoring well.

If a statistically significant change from background of any tested constituent at any monitoring well has occurred, Contractor shall immediately place a notice in the operating record describing the increase.

If a statistically significant change from background of any tested constituent at any monitoring well has occurred and the Contractor has reasonable cause to think that a source other than the solid waste landfill caused the contamination or that the statistically significant change resulted from error in sampling, analysis, statistical evaluation, or natural variation in groundwater quality, then the Contractor shall submit a report providing documentation to this effect. The report shall be prepared by a qualified groundwater scientist and submitted to ESSO for review and approval not later than 90 days after the sampling event.

ESSO EXPLORATION & PRODUCTION CHAD INC. 	SOLID WASTE LANDFILL	CCS 13-4-1 Page 26 of 27	
TECHNICAL SPECIFICATION		Rev. 0	11 Nov 96


6.6 Records

The Contractor shall maintain disposal records covering at least the following:

- a. Major operational problems or difficulties.
- b. Qualitative and quantitative evaluations of the environmental impact of the disposal site including results of:
 1. Leachate sampling and analysis;
 2. Ground and surface water quality sampling and analysis upstream and downstream of the site.
 3. Source of daily, intermediate and final cover material.
 4. Waste compaction.
 5. Gas generation and gas control procedures.
 6. Vector control efforts.
 7. Dust and litter control efforts.
- c. Quantitative measurements of the solid wastes handled, accomplished through routine or periodic utilization of scales and topographic surveys of the site.
- d. Description of amounts and types of solid waste materials received in each landfill cell identified by source of materials, as per the database required by Coordination Procedure Section 30. This database shall be turned over to ESSO at project completion.
- e. Location and development of cells used by the Contractor.

#7.0 CLOSURE REQUIREMENTS

- 7.1 Within 180 days of the last receipt of wastes generated during construction, the Contractor shall complete the installation of a final cover system for the landfill cells used during the pre-operations phase that is designed and constructed to minimize infiltration and erosion. The final cover system shall be composed of no less than 750 mm (2.5 ft.) of soil and consist of an infiltration layer overlain by an erosion layer as follows:
 - a. The infiltration layer shall consist of a minimum of 450 mm (18 in.) of earthen material with a coefficient of permeability no greater than 1×10^{-5} cm/sec (3.94×10^{-6} in/sec) overlain by a synthetic membrane that has a permeability less than or equal to the permeability of the bottom liner system. The minimum thickness of the synthetic membrane shall be 0.5 mm (20 mils), or 1.5 mm (60 mils), in the case of HDPE, in order to ensure proper seaming of the synthetic membrane.
 - b. The erosion layer shall consist of a minimum of 300 mm (12 in.) of earthen material that is capable of sustaining native plant growth and shall be seeded

ESSO EXPLORATION & PRODUCTION CHAD INC. 	SOLID WASTE LANDFILL	CCS 13-4-1 Page 27 of 27	
TECHNICAL SPECIFICATION		Rev. 0	11 Nov 96

or sodded immediately following the application of the final cover in order to minimize erosion.

- 7.2 The Contractor shall submit to ESSO for approval a written final closure plan that describes the steps necessary to close the landfill cells used during the pre-operations phase. The final closure plan, at a minimum, shall include the following information:
- a. a description of the final cover design and methods and procedures to be used to install the cover;
 - b. an estimate of the largest area of the landfill site ever requiring a final cover at any time during the active life of the landfill;
 - c. an estimate of the maximum inventory of wastes ever on-site over the active life of the landfill and a summary of the types and amounts of waste contained in each landfill cell;
 - d. a schedule for completing all activities necessary to satisfy the closure criteria; and
 - e. a final contour map depicting the proposed final contours, establishing top slopes and side slopes, proposed surface drainage features, and protection of any 100-year flood-plain.
- 7.3 No later than 45 days prior to the initiation of closure activities for the landfill cells used during the pre-operations phase, the Contractor shall provide written notification to ESSO of the intent to close the cells and place this notice of intent in the operating record.
- 7.4 Following receipt of the required final closure documents, ESSO shall acknowledge the termination of operation and closure of the cells and evaluate whether they are properly closed. Contractor shall correct any deficiencies identified by ESSO in its evaluation.
- #7.5 Quality control testing documentation is as follows:
- a. The Contractor is responsible for placing and compacting clay soils for the final cover infiltration layer.
 - b. The Contractor shall test the 450 mm (18 in.) of compacted material for its coefficient of permeability at a frequency of no less than one test per surface acre of final cover.
 - c. Permeability data shall be submitted to ESSO for approval.



SOIL EROSION MITIGATION

Changes shown by =>

Rev. No.	Date	Prepared By	Reviewed By	Approved By
		Discipline Engineer	Engineering Manager	Project Engineer / Manager
0	18 Nov 96	C.K. Owens	P.R. Scheltema	M.A. Stuchly
1	30 Oct 97	M.E. Fedak	<i>P.R. Scheltema</i>	<i>Michael A. Stuchly</i>

Changes shown by ⇒

TABLE OF CONTENTS

1.0 GENERAL 3

2.0 SOIL EROSION MITIGATION 3

TABLES AND FIGURES

TABLE 1: SPACING FOR TRENCH PLUGS 6

TABLE 2: TEMPORARY WATERWAY CROSSING MATERIALS 8

TABLE 3: MAXIMUM NONEROSIVE CHANNEL VELOCITIES 9

FIGURE 1: TOPSOIL STRIPPING 11

FIGURE 2: SEDIMENT BARRIER FILTER FABRIC 12

FIGURE 3: FABRIC FENCE SEDIMENT 13

FIGURE 4: DIVERSION DIKE 14

FIGURE 5: DIVERSION DIKE CONFIGURATIONS AND SPACING 16

FIGURE 6: TRENCH PLUG 17

FIGURE 7: TIMBER BRIDGE 18

FIGURE 8: BRIDGE WITH CULVERTS 19


FIGURE 9: STONE FORD TEMPORARY CONTROL MEASURE 20

FIGURE 10: EROSION CONTROL BLANKET 21

FIGURE 11: RIP RAP 24

FIGURE 12: RIP RAP OUTLET 26

FIGURE 13: DESIGN CHART FOR RIP RAP LININGS 29

ESSO EXPLORATION & PRODUCTION CHAD INC.  SPECIFICATION	SOIL EROSION MITIGATION	CCS 21-20-107	
		Page 3 of 29	
		Rev. 1	Oct. 1997

Changes shown by ⇒

1.0 GENERAL

This specification covers the design and installation of soil erosion mitigation measures to be used to control the amount of sediment removed from project areas by natural forces such as wind and rain. Contractor's responsibilities with respect to soil preservation are also discussed in the environmental management Coordination Procedure (Section 30) in the Job Specification.


In general, temporary erosion control procedures shall be directed toward preventing soil erosion at the source, preventing silt and sediment from entering waterways and migrating downstream if soil erosion cannot be prevented. Permanent erosion control measures shall be implemented to prevent sedimentation of the drainage system and to prevent erosion of the project area.

Temporary erosion and sedimentation control devices shall be installed and maintained from the initial land disturbance activity until the satisfactory completion and establishment of permanent erosion control measures. At that time, temporary devices shall be removed.

2.0 SOIL EROSION MITIGATION

At a minimum, Contractor shall apply the following principles in implementing effective erosion control:

- Construction activities shall be sequenced to minimize the amount of area disturbed at one time. Final grading, clean-up and restoration/reclamation shall be completed as soon as possible after construction is completed.
- Overland flow from upslope areas shall be diverted around disturbed areas to minimize the amount of erosion-generating runoff from the disturbed area.
- Measures that break slopes and diffuse flows or divert flows to stabilized outlets shall be used to reduce problems associated with concentrated flows and velocities resulting from clearing vegetation.
- Temporary or permanent stabilization of exposed soils shall be provided as soon as practicable after construction activity ceases. Stabilization practices include but are not limited to seeding, mulching, geotextiles, sodding, and riprap.

ESSO EXPLORATION & PRODUCTION CHAD INC.  SPECIFICATION	SOIL EROSION MITIGATION	CCS 21-20-107	
		Page 4 of 29	
		Rev. 1	Oct. 1997

Changes shown by ⇒

2.1 Topsoil Stripping and Preservation

⇒ Contractor shall strip and preserve topsoil (Figure 1) and use it to provide a suitable growth medium for revegetation of disturbed areas. In cultivated and pasture areas, topsoil shall be stripped from the excavation area of any installation (pipeline, building, roadway, drilling pad, etc.) and from any surrounding area used during construction to provide access or storage. In other locations (e.g. forest, open savanna, developed areas), only the excavation area of the intended installation and subsoil spoil areas shall be stripped unless the level of activity and site specific conditions dictate otherwise. Topsoil shall be stripped to a minimum depth of 150 millimeters. The actual topsoil depth can vary depending on the location. Topsoil shall be segregated from subsoil, and topsoil shall be stockpiled on the uphill side of the installation. Stockpiles shall not extend through watercourses.

⇒ With prior ESSO written approval, one or more alternate techniques that provide at least the same level of resource protection (e.g., scarification, surface texturing, mulching, fertilizing, seeding, seedling planting, etc.) may be used to control soil erosion and facilitate the establishment of appropriate vegetation.


During site restoration, disturbed areas shall be scarified 70 to 100 millimeters to relieve compaction before respreading topsoil. Topsoil shall be uniformly distributed over the recontoured surface to a minimum compacted depth of 70 millimeters on 3(H):1(V) slopes and 120 millimeters on flatter slopes. The topsoil shall not be spread while muddy or when the subsoil is wet. Irregularities in the surface that result from this and other operations shall be corrected to prevent depressions and water pockets. The topsoil shall be compacted enough to ensure good contact with the underlying soil; however, excessive compaction shall be avoided. Light packing with a roller is recommended.

In Work Site areas where topsoil was not stripped, the surface shall be ripped or scarified 70 to 100 millimeters to relieve compaction as the last activity over the area.

2.2 Sediment Barrier

Contractor shall construct a temporary sediment barrier (Figure 2) at the perimeter of a disturbed area to intercept and retain sediment. This practice shall be applied below disturbed areas subject to sheet or rill erosion.

During clearing and grubbing operations, equipment shall be utilized to create, where possible, a sediment barrier by pushing or dumping a mixture of limbs, small vegetation, and root mat with minor amounts of soil and rock into windrows along the toe of a slope where erosion and accelerated runoff is

ESSO EXPLORATION & PRODUCTION CHAD INC.  SPECIFICATION	SOIL EROSION MITIGATION	CCS 21-20-107	
		Page 5 of 29	
		Rev. 1	Oct. 1997

Changes shown by ⇒

expected. A filter fabric anchored over the berm shall be utilized to enhance the filtration ability of the barrier.

The following are the construction specifications for the sediment barrier:

- The sediment barrier shall have a minimum height of 1 meter.
- The width of the sediment barrier shall be a minimum 2 meters at its base.
- The barrier shall be constructed by piling brush, stone, root mat, and other material from the clearing process into a mounded row on the contour.

Alternatively, if clearing and grubbing operations do not generate enough debris to create the sediment barrier shown in Figure 2, Contractor shall modify the design to create a vertical silt fence with the filter fabric as shown in Figure 3.

2.3 Diversion Dikes

Contractor shall construct a dike across the slope of a disturbed area to redirect sheet flow or concentrated flow runoff around disturbed areas to a stabilized outlet where water can be discharged without adversely affecting the receiving area or channel. It can also serve as an interceptor dike to shorten the length of exposed slopes by intercepting runoff and diverting it to a stabilized outlet.

This practice (Figures 4 and 5) shall be used upslope of disturbed areas where erosion is likely to occur and runoff protection is needed to prevent erosion, and on sloping access right-of-way or other long, narrow sloping areas less than 30 meters wide.

The dike/swale shall be designed to carry the peak runoff from at least a 24-hour, 2-year frequency storm with a freeboard of not less than 0.1 meter. The draining area shall not exceed 2 hectares.

The top width shall be 0.5 meter minimum. The height shall be 0.5 meter measured from the bottom of the swale. The side slopes shall be 2(H):1(V) or flatter. The grade shall be positive, not exceeding 2 percent.

The spacing for diversion dikes shall be in accordance with Figure 5.

Each diversion dike or interceptor shall have an adequate outlet capable of conveying runoff to a location where the discharge does not have adverse impact.

Changes shown by ⇒

2.4 Trench Plugs

Contractor shall place a barrier consisting of sand bags around the pipeline to obstruct water flow or seepage along the pipeline, thereby controlling erosion of the trench backfill material. Sand bags shall contain 5 percent by weight of cement.

This practice (Figure 6) shall be used along a pipeline trench where the slope exceeds 5 percent. The spacing for trench plugs shall be in accordance with Table 1.

Contractor shall dig shallow ditches as necessary to channel water diverted by the ditch plugs away from the pipe trench.

Table 1
Spacing for Trench Plugs

Slope of Pipeline Trench	Maximum Distance Between Plugs
less than 5%	not required except at watercourses
5 to 15%	90 m
15 to 25%	60 m
25 to 35%	30 m
larger than 35%	15 m


2.5 Temporary Waterway Crossings

2.5.1 General

Contractor shall install temporary structures across streams or waterways for short-term use by construction vehicles and heavy equipment to prevent damage to the watercourse or the deposition of sediment into the watercourse. Exceptions may be made for rock bottom watercourses. Exceptions must be approved by ESSO.

This practice shall be used where heavy equipment must be moved from one side of the watercourse to another or light-duty construction vehicles must cross the watercourse frequently for a short time period.

The travelway for all structures shall be a minimum 5 meters wide. The structure shall be designed to pass 60 percent of the bank-full flow or the peak flow from a 24-hour, 2 year frequency storm (whichever is less) without overtopping.

ESSO EXPLORATION & PRODUCTION CHAD INC.  SPECIFICATION	SOIL EROSION MITIGATION	CCS 21-20-107	
Page 7 of 29			
Rev. 1		Oct. 1997	

Changes shown by ⇒

Contractor shall ensure that erosion does not result from the 10-year peak storm. Overtopping is allowed during the 24-hour, 10-year frequency storm if contained within the limits of the channel banks.

Contractor shall ensure that the design flow velocity at the crossing structure's outlet is nonerosive for the receiving channel.

If the slope above the stream banks is more than 2 percent, a diversion dike shall be placed above the stream banks to divert surface runoff away from the disturbed channel section and discharge the runoff to a stable outlet.

2.5.2 Bridge

A temporary bridge (e.g., Figure 7) shall consist of wood or metal and be designed to support the maximum expected load.

Bridges shall be securely anchored at only one end using steel cable or chain. Anchoring shall prevent the bridge from floating downstream.

2.5.3 Bridge with Culverts

A temporary bridge with culverts (Figure 8) shall be designed to support the maximum expected load. The minimum culvert size shall be 0.3 meter (12 inch) nominal diameter. The culvert shall extend a minimum 0.5 meter beyond the upstream and downstream toe of the aggregate placed around the culvert. The maximum culvert size shall be 12 meters in length.

The culvert shall be covered with a minimum 0.3 meter of aggregate fill. If multiple culverts are used, they shall be separated by at least 0.3 meter of compacted aggregate fill.

Filter fabric shall be placed on the streambed and stream banks prior to placement of the pipe culvert(s) and aggregate. The filter fabric shall cover the streambed and extend 0.5 meter beyond the end of the culvert and bedding material.

Changes shown by ⇒

2.5.4 Fords

Fords can be constructed at watercourses where the bank height is less than 1.5 meters and the flow is intermittent. Approach sections shall be graded to a maximum 5(H):1(V) slope.

All fords shall be constructed to minimize the blockage of stream flow and allow free flow over the ford (Figure 9).

The ford shall be stabilized with a layer of stone aggregate placed on filter fabric. All areas disturbed by ford installation shall be stabilized.

2.5.5 Materials

The materials used for temporary waterway crossings shall be in accordance with Table 2.

Table 2
Temporary Waterway Crossing Materials

Item	Materials
Temporary bridges	Prefabricated wood or steel
Culverts	Steel pipe, reinforced concrete pipe, or corrugated steel
Aggregate fill	Clean stone, ASTM D448, Size No. 1 (40 to 90 mm)
Filter fabric	Woven geotextile, EXXON GTF-200 or approved equivalent

2.6 Vegetative Lining Stabilization

Contractor shall place a fabric matrix (erosion control blanket) consisting of natural fibers over seedbeds, channels, or steep slopes to prevent erosion by providing a protective cover during the establishment period of protective vegetation.

This practice (Figure 10) shall be used in the following situations:

- Waterways where channel velocity exceeds maximum velocities listed in Table 3 and
- On slopes of 4(H):1(V) or more where the erosion hazard is high and vegetation likely to be slow to establish adequate protective cover.

Changes shown by ⇒

Table 3
Maximum Nonerosive Channel Velocities

Soil Material	Velocity (m/sec)
Sandy loam	0.75
Alluvial silt ⁽¹⁾	1.00
Stiff clay	1.50

⁽¹⁾Noncolloidal

Channel lining selection shall be based on the Permissible Shear Stress method developed by the United States Federal Highway Administration's Hydraulic Engineering Circular #15, "Design of Roadside Channels with Flexible Linings."

$$T_d = Y \times d \times s$$

Where: T_d = maximum shear stress (kilograms per square meter [kg/m^2] on channel lining

Y = unit weight of water (9.8 kilonewtons per cubic meter)

d = bank-full flow depth in center of channel (meters)

s = channel slope gradient (meters per meter)

Erosion control blanket used shall be straw, coconut, or wood fibers, or equivalent, sewn together with a biodegradable netting. The minimum width shall be 1.25 meters.

For anchors, staples shall be No. 11 gauge wire or heavier and 150 to 250 millimeters long.


Placement and installation shall be in accordance with the manufacturer's specifications.

2.7 Riprap

Contractor shall place a layer of crushed concrete, rock, or stone (i.e., riprap) over an erodible soil surface to provide a permanent protective cover against erosion (Figures 11 and 12).

Riprap shall be used in the following situations:

- Waterways where soil conditions, vegetative cover, and water velocity are such that erosion can occur under the design flow conditions and

<p>ESSO EXPLORATION & PRODUCTION CHAD INC.</p>  <p>SPECIFICATION</p>	<p>SOIL EROSION MITIGATION</p>	<p>CCS 21-20-107</p>	
<p>Page 10 of 29</p>			
<p>Rev. 1</p>		<p>Oct. 1997</p>	

Changes shown by ⇒

- Disturbed waterways where vegetative lining stabilization is not adequate for protection against erosion.

The riprap thickness shall be one and a half times the maximum stone size.

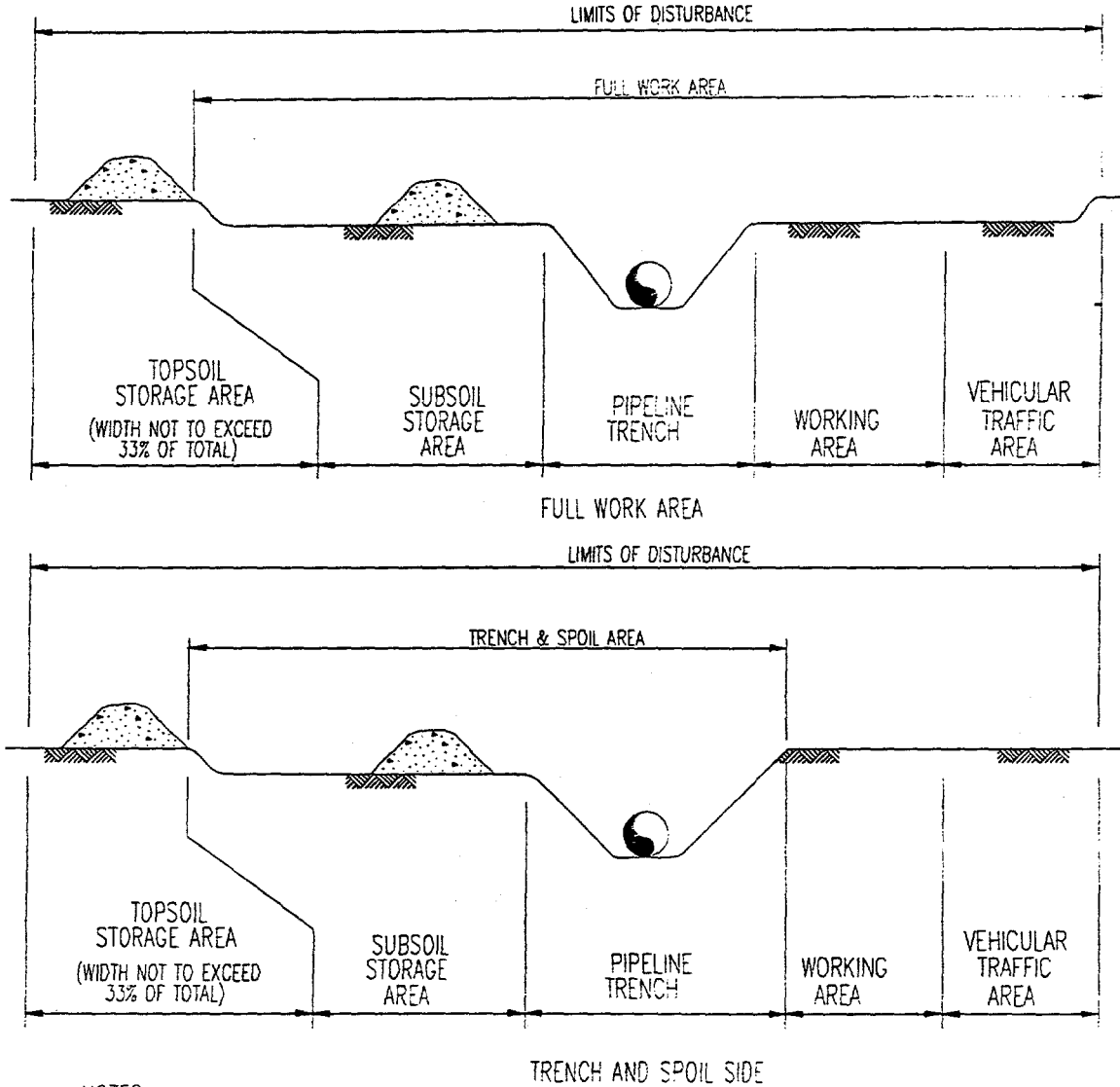
The average stone size shall be selected from Figure 13 and be based on bank-full channel velocity.

Materials for riprap shall be rock or stone with a minimum density of 2,500 kilograms per cubic meter and woven geotextile fabric, EXXON GTF-200 or an approved equivalent shall be used.

Riprap shall be placed on filter fabric or a bedding of graded filter stone.



FIGURE 1
TOPSOIL STRIPPING

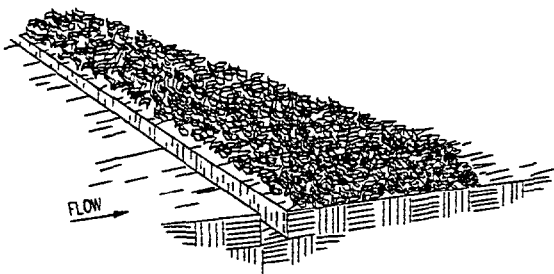


NOTES:

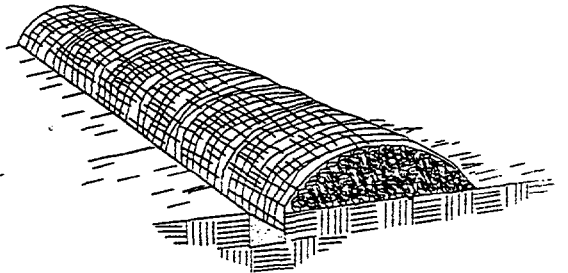
1. THE FULL WORK AREA WIDTH SHALL BE STRIPPED ALONG CULTIVATED AGRICULTURAL AREAS. IN ALL OTHER LOCATIONS, ONLY THE AREA ABOVE THE PIPELINE TRENCH AND THE SUBSOIL SPOIL AREA SHALL BE STRIPPED.
2. PIPELINE TRENCH LOCATION AND SHAPE SHOWN FOR CLARITY ONLY.



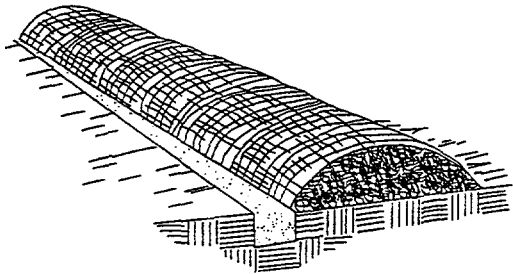
FIGURE 2
SEDIMENT BARRIER
FILTER FABRIC
(OPTIONAL)



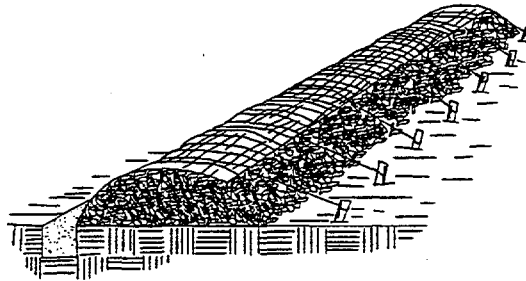
1. EXCAVATE A 10 cm. X 10 cm. TRENCH ALONG THE UPHILL EDGE OF THE SEDIMENT BARRIER.



2. DRAPE FILTER FABRIC OVER THE SEDIMENT BARRIER AND INTO THE TRENCH. FABRIC SHOULD BE SECURED IN THE TRENCH WITH STAKES SET AT A SPACING OF APPROXIMATELY 1 METER.



3. BACKFILL AND COMPACT THE EXCAVATED SOIL.



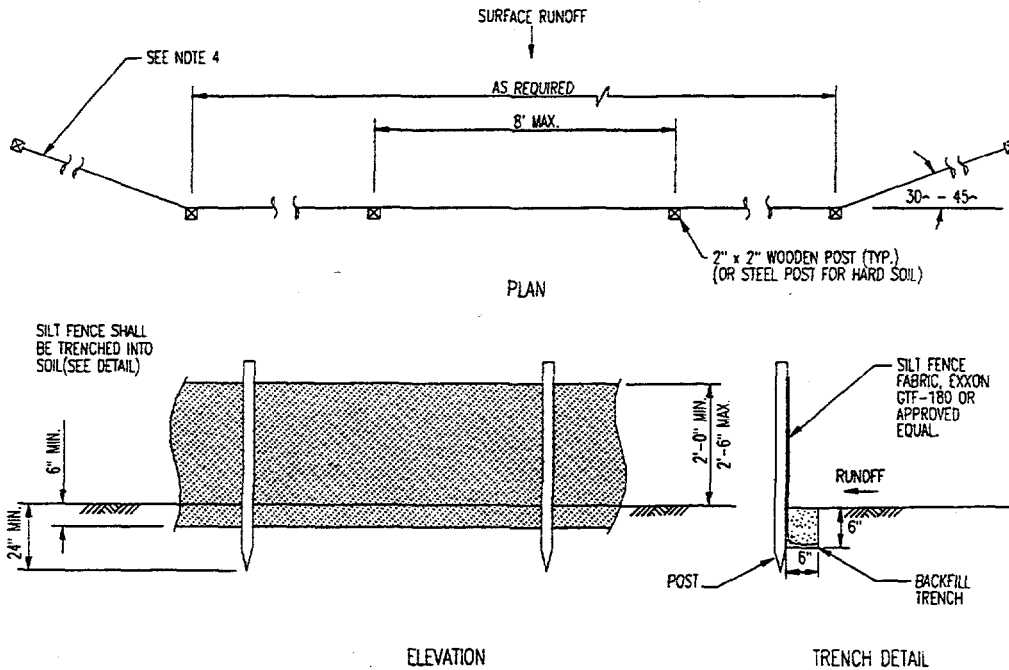
4. SET STAKES ALONG THE DOWNHILL EDGE OF THE SEDIMENT BARRIER, AND ANCHOR BY TYING TWINE FROM THE FABRIC TO THE STAKES.

NOTES:

1. SEDIMENT BARRIERS SHALL BE INSPECTED AFTER EACH SIGNIFICANT RAINFALL AND NECESSARY REPAIRS SHALL BE MADE PROMPTLY.
2. SEDIMENT DEPOSITS MUST BE REMOVED WHEN THEY REACH APPROXIMATELY ONE-HALF THE HEIGHT OF THE BARRIER.

Changes shown by ⇒

FIGURE 3
FABRIC FENCE SEDIMENT BARRIER
TEMPORARY EROSION CONTROL MEASURE

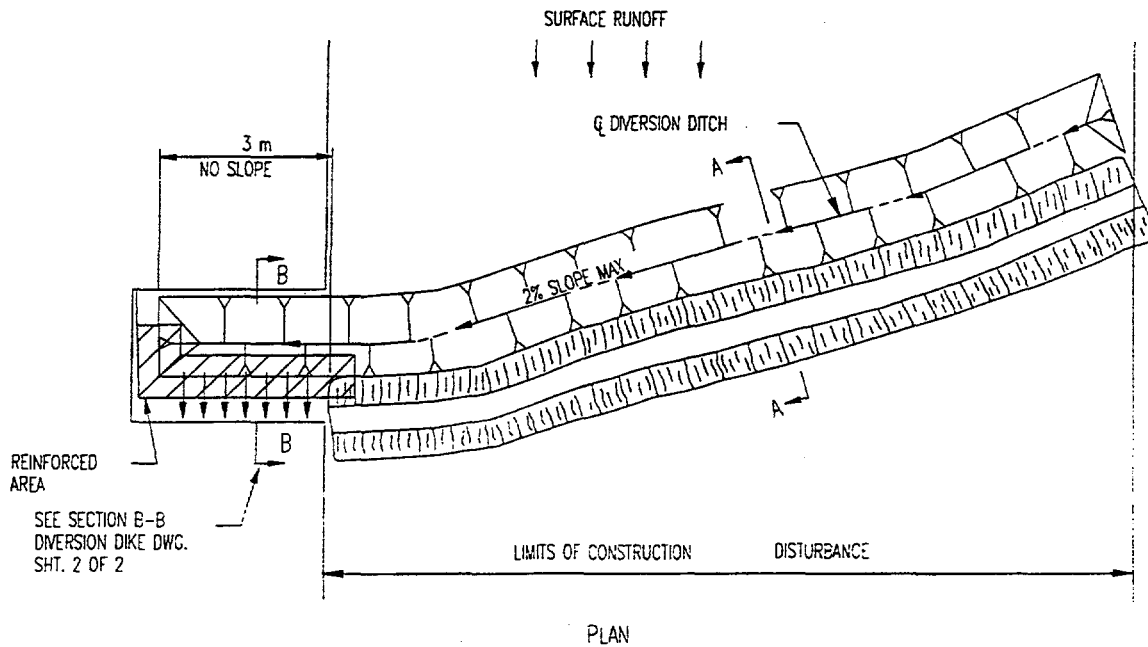
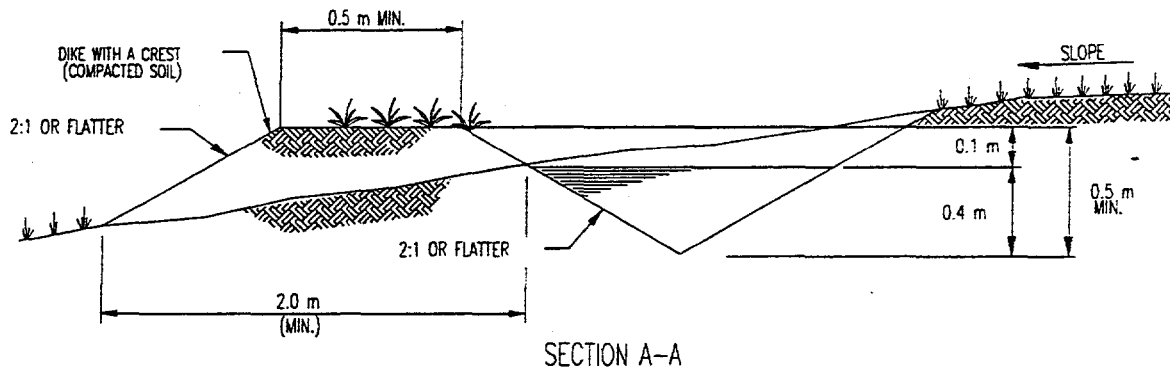


NOTES:

1. SILT FENCE SHALL BE INSTALLED TO FILTER SEDIMENT FROM SURFACE RUNOFF.
2. BUILD-UP OF SEDIMENT SHALL BE REMOVED WHEN SEDIMENT REACHES 1/2 THE ABOVE GROUND HEIGHT OF THE FENCE.
3. SILT FENCES SHALL BE PLACED TO FOLLOW (RUN PARALLEL TO) THE CONTOURS.
4. ON UPSLOPE INSTALLATIONS, BOTH ENDS OF THE SILT FENCE SHALL BE TURNED AND EXTENDED UPSLOPE.

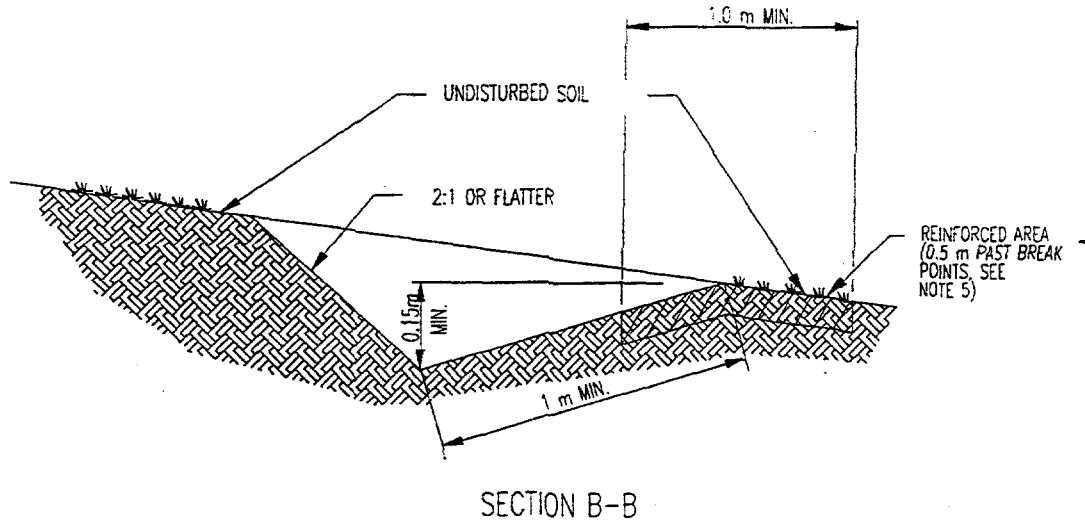


FIGURE 4 - SHT. 1 OF 2
DIVERSION DIKE
PERMANENT EROSION CONTROL MEASURE



Changes shown by ⇒

FIGURE 4 – SHT. 2 OF 2
 DIVERSION DIKE
 PERMANENT EROSION CONTROL MEASURE

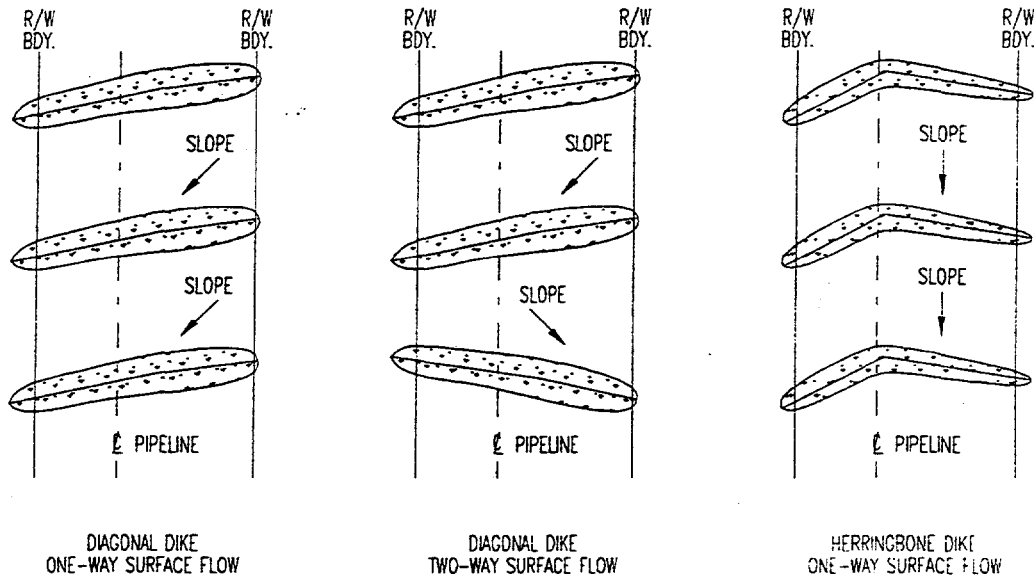


NOTES:

1. DIVERSIONS SHALL BE SPACED AS INDICATED ON THE DRAWINGS.
2. WHERE SLOPE OF CONSTRUCTION AREA EXCEEDS THAT FOR SAFE INSTALLATION, DIVERSIONS SHALL BE INSTALLED AT THE TOP AND BASE OF SLOPE ONLY.
3. DIVERSION DIKE SHALL BE INSTALLED ON A MAXIMUM 2 % SLOPE ACROSS THE RIGHT-OF-WAY.
4. OUTLET MUST BE ON VEGETATED AREA, OR STABILIZED WITH REINFORCEMENT AS SHOWN ON SECTION B-B.
5. REINFORCEMENT CAN BE AN EROSION CONTROL MAT, TURF REINFORCEMENT MAT OR ANY OTHER COMPANY APPROVED MATERIAL.



FIGURE 5
DIVERSION DIKE
CONFIGURATIONS AND SPACING
PERMANENT EROSION CONTROL MEASURE



N.T.S.

NOTES:

1. USE DIAGONAL DIKES WHERE DIRECTION OF SLOPE AND SURFACE WATER MOVEMENT IS OBLIQUE TO PIPELINE RIGHT OF WAY.
2. USE HERRINGBONE DIKES AND CROSS DITCH WHERE DIRECTION OF SLOPE AND SURFACE WATER MOVEMENT IS PARALLEL TO RIGHT OF WAY.
3. DETERMINE LOCATION AND DIRECTION OF DIKE BASED ON LOCAL TOPOGRAPHY AND DRAINAGE PATTERNS. ALSO, INSTALL DIKES IMMEDIATELY DOWNSLOPE OF TRENCH BREAKERS. SKEW DIKES 5° TO PREVENT WATER PONDING BEHIND DIKES. EXTEND DIKES A MINIMUM OF 2M OFF THE RIGHT OF WAY.
4. TYPICAL DIVERSION DIKE SPACING:*

SLOPE GRADIENT (%)	TYPICAL SPACING (M)**
LESS THAN 15	AS REQUIRED
15-20	60
20-25	45
25-30	35
GREATER THAN 30	20-30

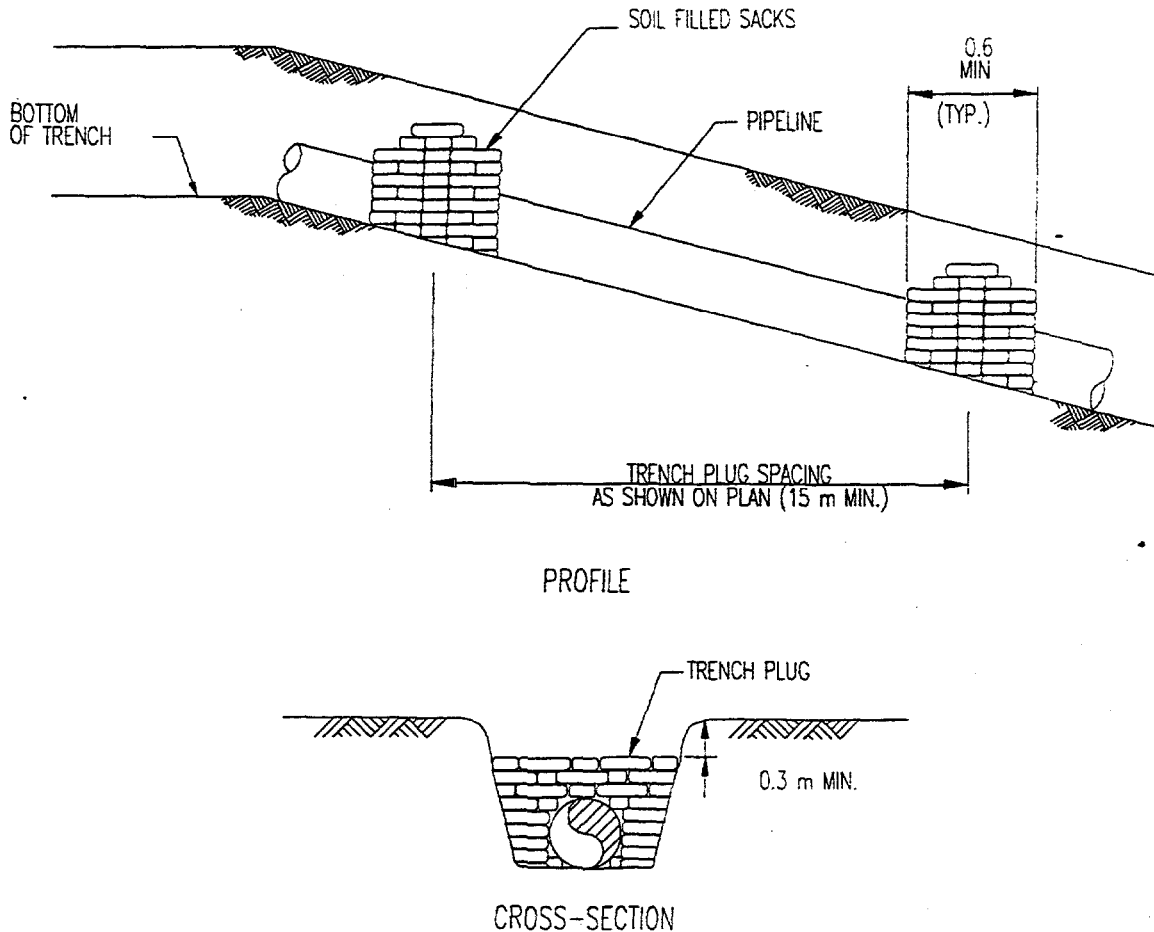
* FROM MARSHALL AND RUBEN, 1963.

** RELY ON FIELD JUDGEMENT TO DETERMINE APPROPRIATE SPACING. FOR EXAMPLE, HIGHLY ERODIBLE MATERIALS, SUCH AS GLACIAL-LACUSTRINE PARENT MATERIALS, INSTALL DIKES APPROXIMATELY 50% CLOSER THAN INDICATED ABOVE.

SOURCE: ALBERTA ENVIRONMENT 1988



FIGURE 6
TRENCH PLUG
PERMANENT EROSION CONTROL MEASURE

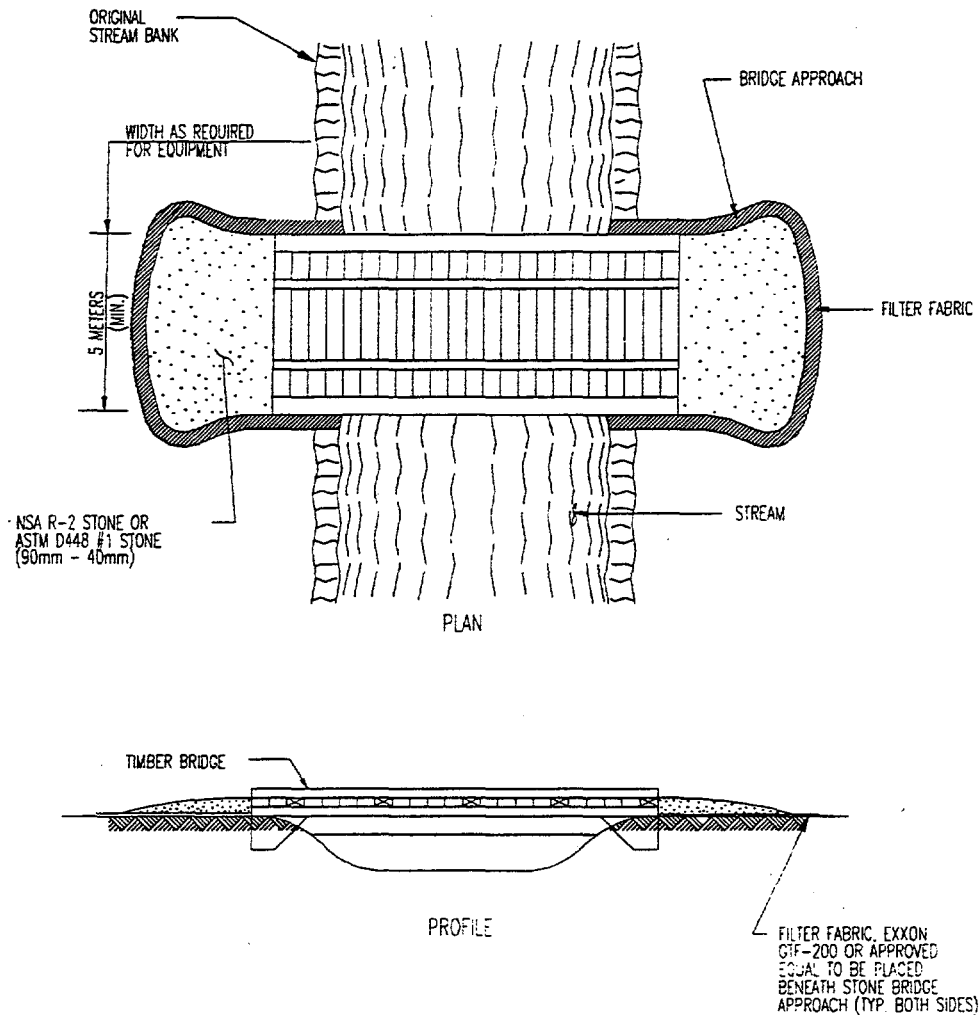


NOTES:

1. TRENCH PLUGS CONSIST OF BURLAP BAGS FILLED WITH SOIL. (TOP SOIL SHALL NOT BE USED IN TRENCH PLUGS).
2. TRENCH PLUGS SHALL BE INSTALLED AT THE BANKS OF ALL MAJOR STREAM CROSSINGS.
3. TRENCH PLUGS SHALL BE LEFT IN PLACE WHEN THE TRENCH IS BACKFILLED.



FIGURE 7
TIMBER BRIDGE
TEMPORARY CONTROL MEASURE

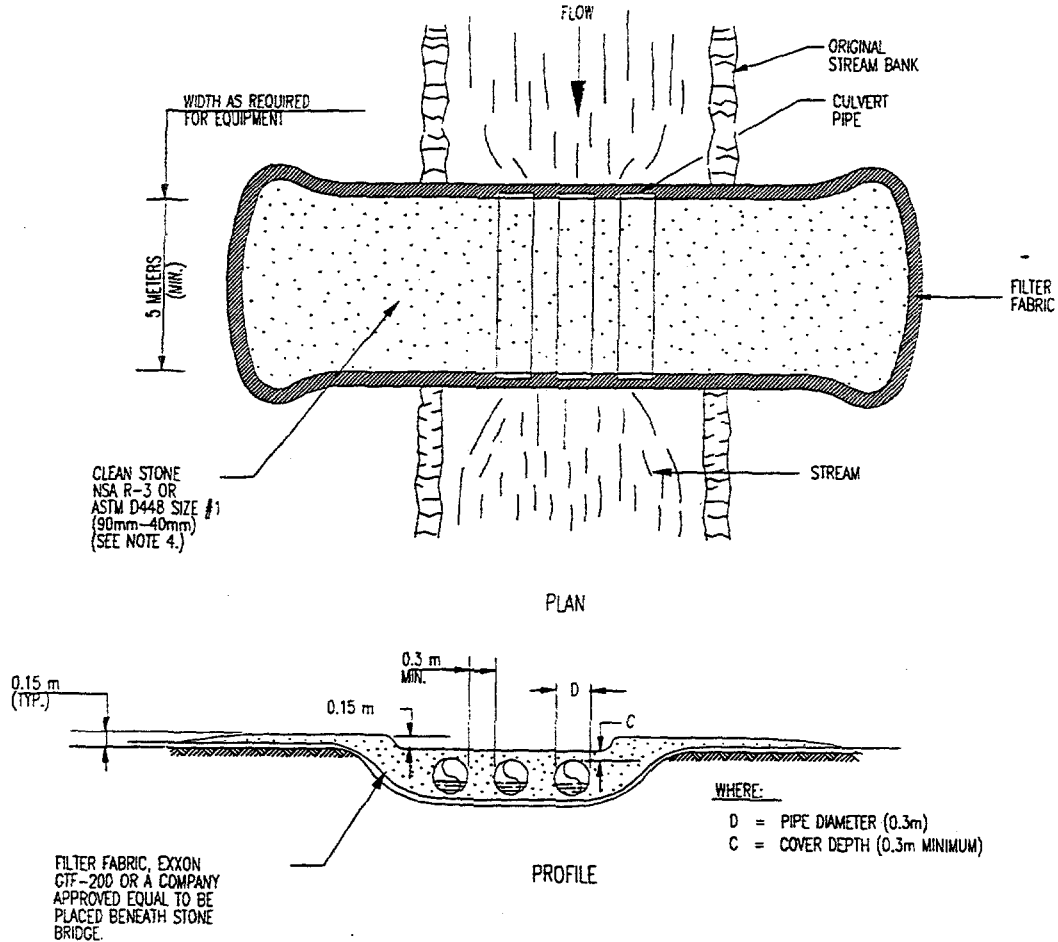


NOTES:

1. TIMBER BRIDGES SHALL BE ADEQUATELY ANCHORED ON AT LEAST ONE END.
2. PERIODICALLY CHECK BRIDGE INSTALLATION AND REMOVE BUILD-UP OF SEDIMENT OR DEBRIS ON BRIDGE.
3. MATERIALS PLACED ALONG STREAM CHANNEL SHALL BE COMPLETELY REMOVED DURING FINAL CLEAN-UP.



FIGURE 8
BRIDGE WITH CULVERTS
TEMPORARY CONTROL MEASURE

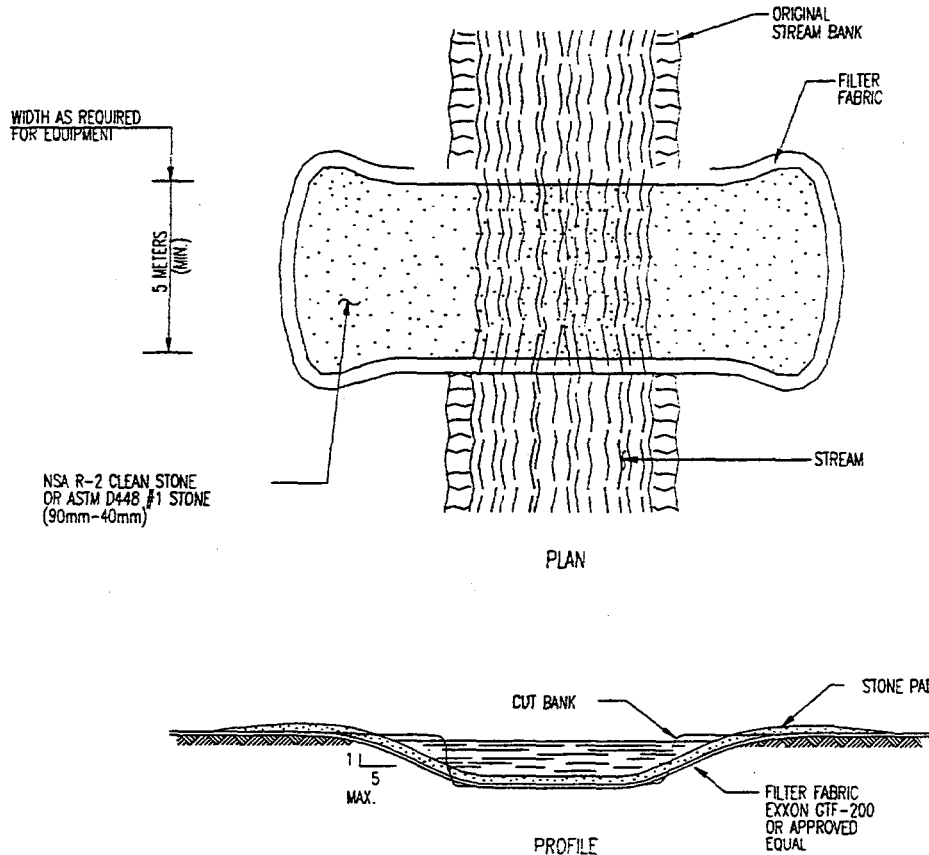


NOTES:

1. PERIODICALLY CHECK BRIDGE INSTALLATION AND REMOVE BUILD-UP OF SEDIMENT OR DEBRIS ON BRIDGE.
2. CULVERT PIPE(S) SHALL BE SIZED AS SHOWN ON PLAN.
3. MATERIALS PLACE IN STREAM CHANNEL SHALL BE COMPLETELY REMOVED DURING FINAL CLEAN-UP.
4. RIPRAP WITH 100mm AVERAGE DIAMETER SHALL BE USED FOR ALL BUT THE TOP 0.1 METER OF STONE.



FIGURE 9
STONE FORD
TEMPORARY CONTROL MEASURE

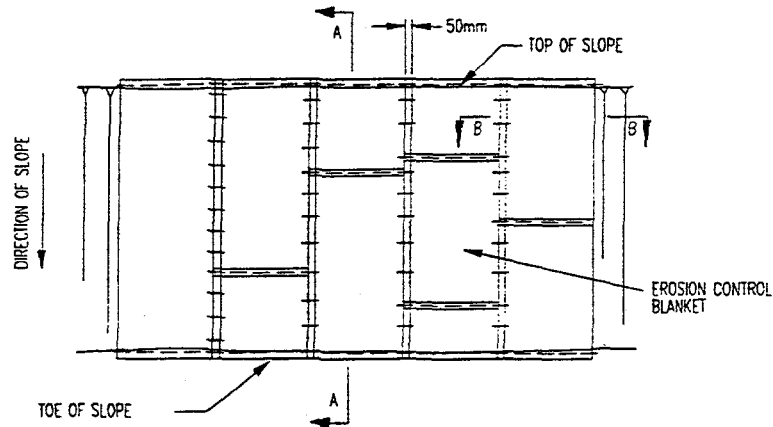


NOTES:

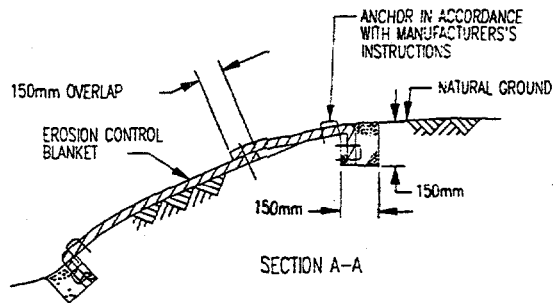
1. THRU-STREAM EQUIPMENT CROSSINGS SHALL BE INSTALLED TO PROVIDE STABLE PASSAGE ACROSS STREAMS, OR OTHER AREAS WHERE BRIDGING IS IMPRACTICAL.
2. MATERIALS PLACED IN STREAM CHANNEL SHALL BE COMPLETELY REMOVED.
3. APPROACHES AT THE CUT BANKS SHALL BE NO STEEPER THAN 5:1.



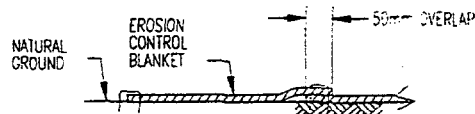
FIGURE 10 - SHT. 1 OF 3
EROSION CONTROL BLANKET
TEMPORARY EROSION CONTROL MEASURE



PLAN



SECTION A-A

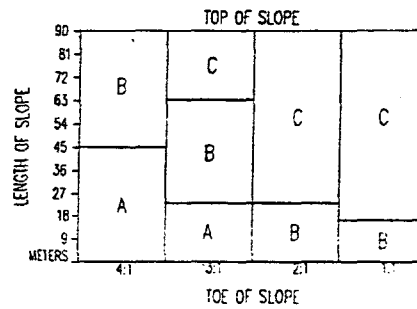


SECTION B-B

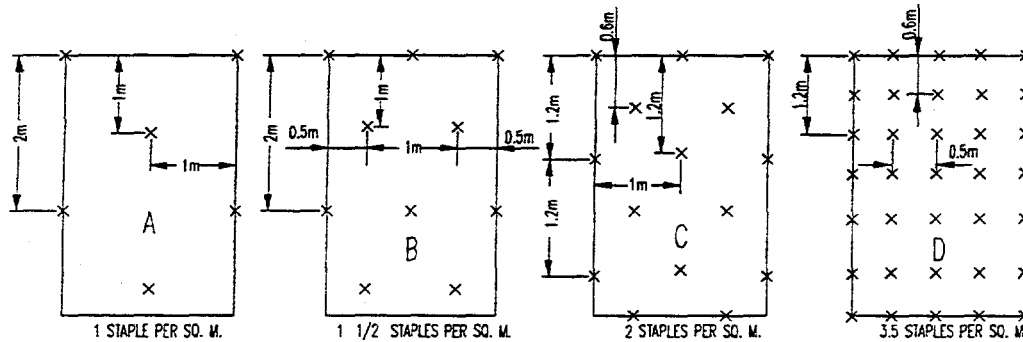
STEEP SLOPE INSTALLATION
> 3:1 SLOPE

FIGURE 10 – SHT. 2 OF 3
EROSION CONTROL BLANKET
TEMPORARY EROSION CONTROL MEASURE

FLOW	STAPLE PATTERN TYPE
LOW VELOCITY	C
MED. TO HIGH VELOCITY	D



STAPLE PATTERN TABLE
(SEE STAPLE PATTERN GUIDE)



STAPLE PATTERN GUIDE

NOTES:

1. USE NORTH AMERICAN GREEN EROSION CONTROL BLANKET OR AN APPROVED EQUAL FOR VEGETATIVE LINING STABILIZATION.
2. EROSION CONTROL BLANKET SHALL EXTEND COMPLETELY ACROSS DISTURBED AREA TO PROTECT ERODIBLE SURFACES.
3. INSTALL ON FRESHLY GRADED AND ON FRESHLY SEED SOIL.


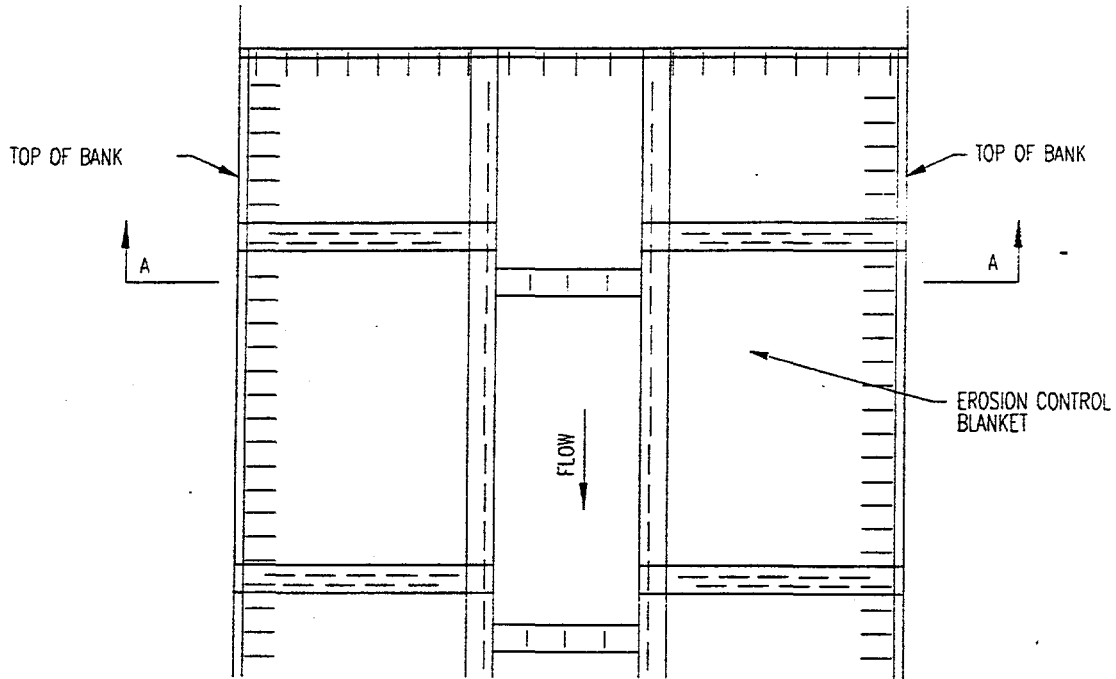
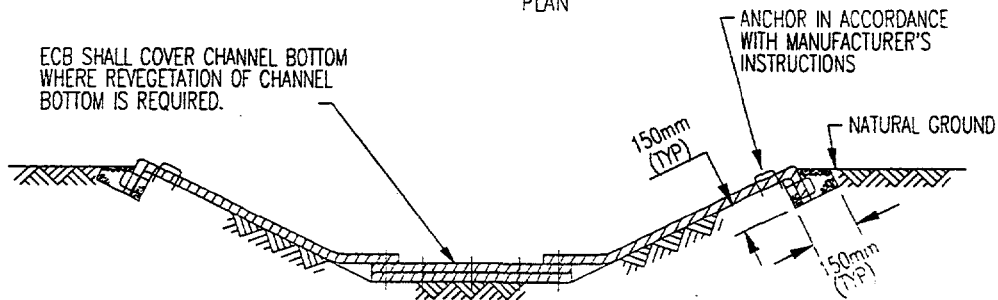
ESSO EXPLORATION & PRODUCTION CHAD INC.  SPECIFICATION	SOIL EROSION MITIGATION	CCS 21-20-107	
		Page 23 of 29	
		Rev. 1	Oct. 1997

FIGURE 10 – SHT. 3 OF 3
 EROSION CONTROL BLANKET
 TEMPORARY EROSION CONTROL MEASURE



PLAN



SECTION A-A

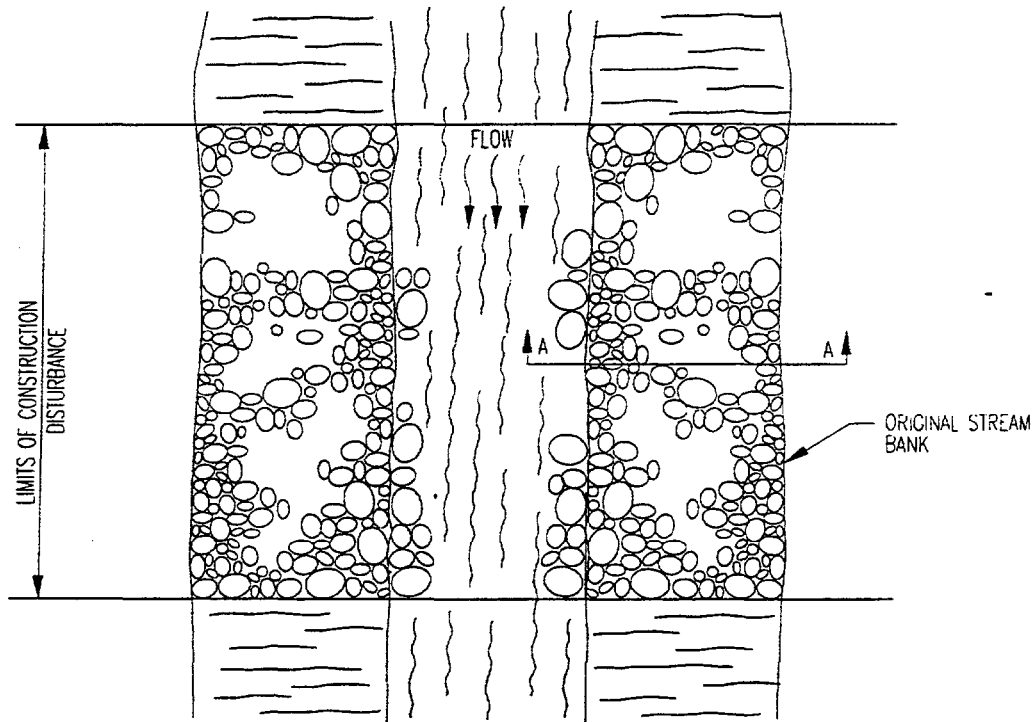
CHANNEL INSTALLATION

NOTES:

1. EROSION CONTROL BLANKET SHALL EXTEND COMPLETELY ACROSS DISTURBED AREA TO PROTECT ERODIBLE SURFACES.
2. INSTALL ON FRESHLY GRADED AND SEEDED SOIL.



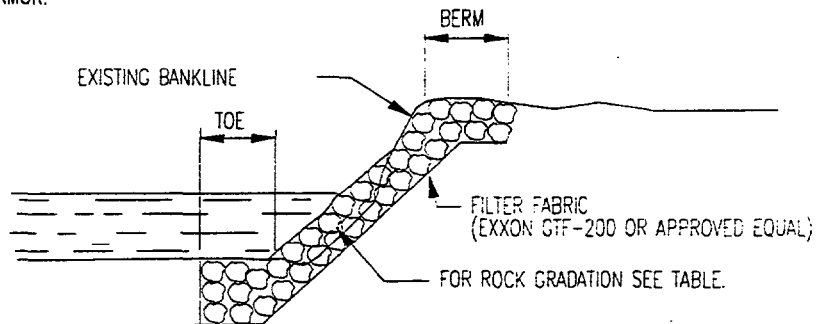
FIGURE 11 - SHT. 1 OF 2
RIP RAP
PERMANENT EROSION CONTROL MEASURE



CONSTRUCTION

PLAN

RIP RAP SHALL BE PLACED TO THE FULL COURSE THICKNESS INDICATED ON THE DRAWINGS IN ONE CONTINUOUS OPERATION. OPERATIONS WHICH CAUSE SEGREGATION OF THE MATERIALS SHALL NOT BE PERMITTED. INDIVIDUAL ROCKS MAY BE REARRANGED, AND THE VOIDS FILLED WITH HAND PLACED SMALLER ROCK IN ORDER TO ACHIEVE THE DESIRED UNIFORM ARMOR.



SECTION A-A

FIGURE 11 – SHT. 2 OF 2
 RIP RAP
 PERMANENT EROSION CONTROL MEASURE

NATIONAL STONE ASSOCIATION RIP RAP GRADATION TABLE SIZE OF ROCKS IN CENTIMETERS						
NSA NUMBER	MAXIMUM	D ₅₀ AVERAGE *	MINIMUM **	MIN. THICKNESS OF RIPRAP LAYER (CM.)	TOE	BERM
					(METERS)	
R-3	15	8	5	23	0.5	0.5
R-4	30	15	8	45	0.75	0.75
R-5	46	23	13	69	1.2	1.2

* THE "AVERAGE SIZE," OR d₅₀, IS DEFINED AS A SIZE THAT IS EXCEEDED BY AT LEAST 50% OF THE TOTAL WEIGHT SHIPPED. (I.E., 50% OF THE TONNAGE SHIPPED SHALL CONSIST OF PIECES LARGER THAN THE "AVERAGE SIZE" SHOWN IN CHART.)

** PIECES SMALLER THAN THE "MINIMUM SIZE" SHOWN SHALL NOT EXCEED 15% OF THE TONNAGE SHIPPED.

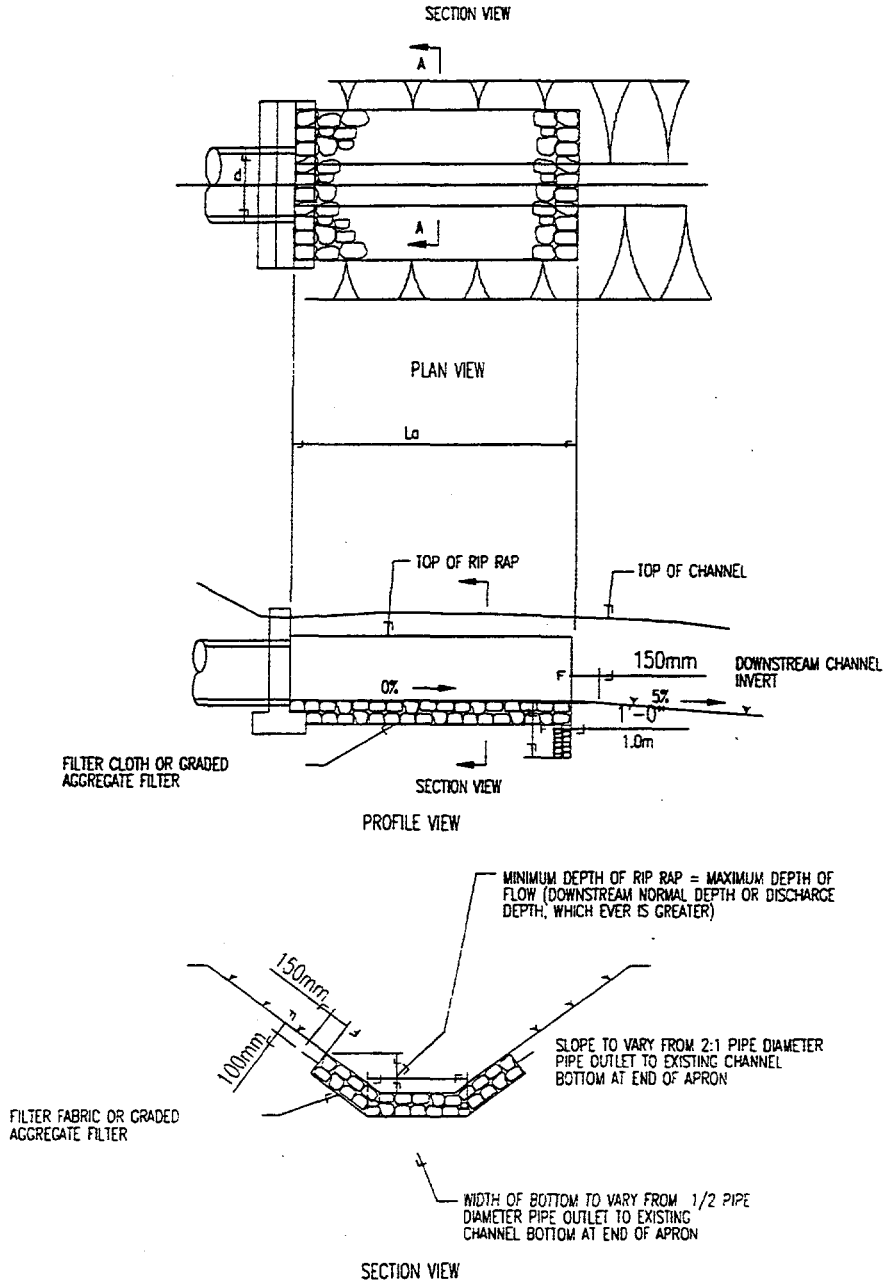
NOTES:

1. ROCK UTILIZED FOR RIP RAP SHALL CONSIST OF CLEAN, DURABLE ROCK, INSOLUBLE IN WATER, AND RESISTANT TO WEATHERING.
2. ALL MATERIAL SHALL BE FREE OF STRUCTURAL DEFECTS, SHALE SEAMS, AND ORGANIC MATTER.
3. INDIVIDUAL PIECES SHOULD BE SHARPLY ANGULAR, BLOCK SHAPED, AND HAVE A MINIMUM SPECIFIC GRAVITY OF 2.5.
4. NO PIECE SHALL HAVE A LENGTH EXCEEDING THREE (3) TIMES ITS WIDTH OR DEPTH.
5. EACH LOAD OF ROCK SHALL BE OF A WELL-GRADED MIXTURE. A WELL-GRADED MIXTURE, AS USED HEREIN, IS DEFINED AS A MIXTURE COMPOSED PRIMARILY OF LARGER STONE, BUT WITH A SUFFICIENT MIXTURE OF SMALLER SIZES TO FILL THE VOIDS.



SOIL EROSION MITIGATION

FIGURE 12 - SHT. 1 OF 3
RIP RAP OUTLET
CHANNEL





SOIL EROSION MITIGATION

Changes shown by =>

FIGURE 12 SHT. 2 OF 3
RIP RAP OUTLET - UNCONFINED

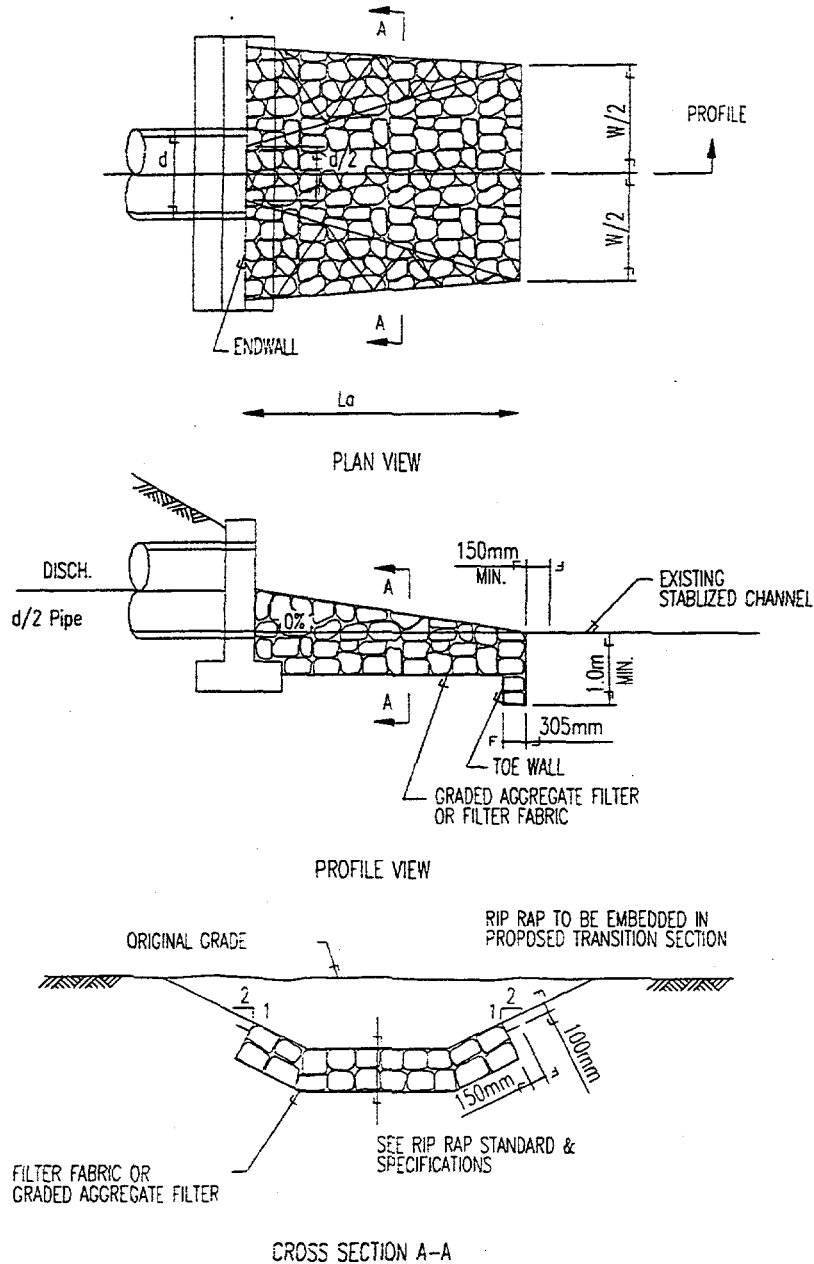


FIGURE 12 – SHT. 3 OF 3
 RIP RAP
 PERMANENT EROSION CONTROL MEASURE

NATIONAL STONE ASSOCIATION RIP RAP GRADATION TABLE				
NSA NUMBER	SIZE OF ROCKS IN CENTIMETERS			
	MAXIMUM	D ₅₀ AVERAGE *	MINIMUM **	MIN. THICKNESS OF RIPRAP LAYER (CM.)
R-3	15	8	5	23
R-4	30	15	8	45
R-5	46	23	13	69

* THE "AVERAGE SIZE," OR d₅₀, IS DEFINED AS A SIZE THAT IS EXCEEDED BY AT LEAST 50% OF THE TOTAL WEIGHT SHIPPED. (I.E., 50% OF THE TONNAGE SHIPPED SHALL CONSIST OF PIECES LARGER THAN THE "AVERAGE SIZE" SHOWN IN CHART.)

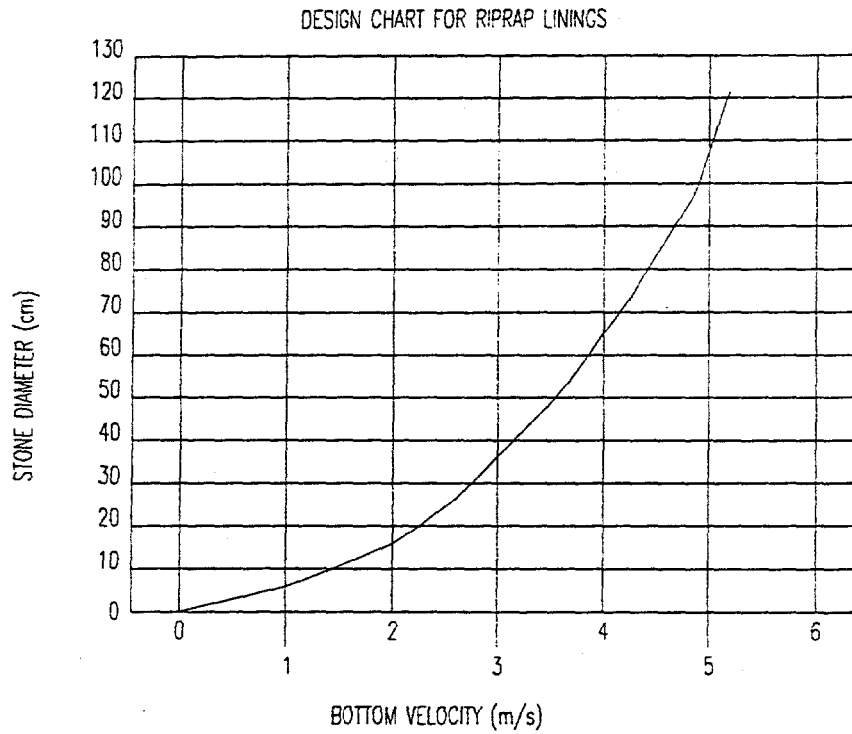
** PIECES SMALLER THAN THE "MINIMUM SIZE" SHOWN SHALL NOT EXCEED 15% OF THE TONNAGE SHIPPED.


NOTES:

1. ROCK UTILIZED FOR RIP RAP SHALL CONSIST OF CLEAN, DURABLE ROCK, INSOLUBLE IN WATER, AND RESISTANT TO WEATHERING.
2. ALL MATERIAL SHALL BE FREE OF STRUCTURAL DEFECTS, SHALE SEAMS, AND ORGANIC MATTER.
3. INDIVIDUAL PIECES SHOULD BE SHARPLY ANGULAR, BLOCK SHAPED, AND HAVE A MINIMUM SPECIFIC GRAVITY OF 2.5.
4. NO PIECE SHALL HAVE A LENGTH EXCEEDING THREE (3) TIMES ITS WIDTH OR DEPTH.
5. EACH LOAD OF ROCK SHALL BE OF A WELL-GRADED MIXTURE. A WELL-GRADED MIXTURE, AS USED HEREIN, IS DEFINED AS A MIXTURE COMPOSED PRIMARILY OF LARGER STONE, BUT WITH A SUFFICIENT MIXTURE OF SMALLER SIZES TO FILL THE VOIDS.




FIGURE 13
DESIGN CHART FOR RIP RAP LININGS



ESSO EXPLORATION & PRODUCTION CHAD INC.  SPECIFICATION	ENVIRONMENTAL IMPACT MITIGATION	CCS 21-20-108	
		Page 1 of 22	
		Rev. 1	Oct. 1997

Changes shown by ⇒

Rev. No.	Date	Prepared By	Reviewed By	Approved By
		Discipline Engineer	Engineering Manager	Project Engineer / Manager
0	15 Nov 96	C.K. Owens	P.R. Scheltema	M.A. Stuchly
1	30 Oct. 97	M.E. Fedak	<i>J.R. Schutte</i>	<i>Michael A. Stuchly</i>

ESSO EXPLORATION & PRODUCTION CHAD INC.  SPECIFICATION	ENVIRONMENTAL IMPACT MITIGATION	CCS 21-20-108	
		Page 2 of 22	
		Rev. 1	Oct. 1997


Changes shown by ⇒

TABLE OF CONTENTS

1.0 SCOPE.....	3
2.0 BASELINE ASSESSMENT AND SITE MONITORING	3
3.0 GENERAL MITIGATION MEASURES	3
4.0 EFFLUENT WATER CRITERIA.....	4
5.0 AIR EMISSIONS CRITERIA	5
6.0 SOIL PROTECTION MITIGATIONS.....	7
7.0 WATER-BODY AND WETLAND PROTECTION MEASURES	8
8.0 CONTROL OF WORK SITE DISTURBANCE AREA.....	8
9.0 MITIGATION OF CONSTRUCTION RELATED IMPACTS	9
10.0 SURFACE RESTORATION.....	17
11.0 SITE RECLAMATION.....	19

LIST OF TABLES

TABLE 1 WORLD BANK LIQUID EFFLUENT CRITERIA.....	4
TABLE 2 WORLD BANK AMBIENT AIR QUALITY CRITERIA.....	5
TABLE 3. DESIGN PARAMETERS FOR AIR EMISSIONS MODELING.....	6

ESSO EXPLORATION & PRODUCTION CHAD INC.  SPECIFICATION	ENVIRONMENTAL IMPACT MITIGATION	CCS 21-20-108	
		Page 3 of 22	
		Rev. 1	Oct. 1997

Changes shown by ⇒

1.0 Scope

Measures to protect the Work Site and surrounding areas from unacceptable impacts are defined in this specification. General measures that apply to all elements of the project are discussed. Other technical specifications include provisions to mitigate impacts resulting from their specific activity/unit.

Sections, below, on baseline assessment and site monitoring, effluent water criteria, air emissions criteria and soil protection mitigations contain information that needs to be considered during the design of Contractor's temporary and permanent facilities and parameters to be monitored during the Work.

Soil protection, water-body and wetland protection, control of Work Site area, and mitigation of construction related impacts sections contain information on how Contractor's in-country Work shall be conducted in order to minimize environmental impacts. Sections on surface restoration and site reclamation provide additional requirements that need to be met before closure of temporary Work Sites and Acceptance of the Work by ESSO.

Contractor's environmental monitors shall be able to suspend activities if these activities are clearly having a markedly adverse effect on the environment (for instance, in periods of heavy rainfall it may be necessary to cease earth-moving activities, without stopping all of the Work).

2.0 Baseline Assessment and Site Monitoring

In accordance with the Coordination Procedure, Contractor shall document Work Site conditions before beginning the Work in a given area. Contractor shall note the type of environment and current condition (e.g., evidence of human impacts or natural soil erosion). Contractor shall sample surface water and ground water (if appropriate) and document the water quality.

Surface effluents from Work activities will be monitored daily and resulting changes in surface water quality recorded.

Work Site conditions, and relevant soil and water samples shall be analyzed and reported to ESSO upon completion of Work Site restoration activities. Samples shall be analyzed by a third-party independent laboratory approved by ESSO.

3.0 General Mitigation Measures

Contractor's responsibilities with respect to management of wastes, spill prevention and response, and protection of plant and animal species and habitat, and complementary requirements with respect to air and water pollution and site restoration are as outlined

Changes shown by ⇒

in the Environmental Management Coordination Procedure (Section 30) in the Job Specification.

4.0 Effluent Water Criteria

⇒ All liquid effluents disposed via surface discharge as per Contractor's approved waste management plan as well as any other surface run-off from the Work Site shall meet World Bank effluent standards for waste water. All discharges of treated effluents to perennial surface water bodies must provide for at least a 100:1 dilution of the effluent. Water treatment shall include all processes necessary to achieve these standards. Effluents containing human wastes shall also be treated with 2-5 mg/L chlorine for a minimum of thirty minutes prior to discharge. Key World Bank effluent criteria are shown in Table 1.


Contractor shall test effluents daily for parameters shown in Table 1 using methods in Standard Methods for the Examination of Water and Wastewater (Mary Ann H. Franson, editor, American Public Health Association, 1995). Test results shall be certified by Contractor and the records of said tests kept as per Section 30 of the Coordination Procedure.

**Table 1
 World Bank Liquid Effluent Criteria¹**

Parameter	Maximum Levels
pH	6-9
BOD ₅	< 50 mg/L
Oil and Grease	< 20 mg/L
Heavy Metals, Total (except Barium)	< 10 mg/L
Phenolic Compounds	< 100 mg/L
Total Suspended Solids	< 50 mg/L
Coliform Bacteria	< 400 MPN/100 mL ² (MPN-Most Probable Number)
Temperature - at the edge of the mixing zone	Max 5°C above ambient temperature of receiving waters - max 3°C if receiving waters > 28°C)

Source: The World Bank Environment, Health and Safety Guidelines, Onshore Oil and Gas Development (World Bank, 1995)

1. Maximum daily discharge limits

ESSO EXPLORATION & PRODUCTION CHAD INC.  SPECIFICATION	ENVIRONMENTAL IMPACT MITIGATION	CCS 21-20-108	
		Page 5 of 22	
		Rev. 1	Oct. 1997

Changes shown by ⇒

2. Average monthly concentration (i.e., 30 consecutive days of sampling)

5.0 Air Emissions Criteria

⇒ The contractor shall ensure that air pollutant emissions from facility sources do not cause exceedances of the World Bank ambient air quality concentration standards shown in Table 2 at locations outside the Work Site boundary. ESSO will consider these standards to be met if the air emissions source performance measures given in Table 3 are met. If the measures in Table 3 are not met, then air emission control measures shall be implemented and equipment/facility design modified, as necessary, to comply with these source performance measures. Testing for stack emission rates, exhaust gas temperatures and exhaust gas flow rates shall be measured by Contractor at start-up, and shall be performed in accordance with testing methodologies deemed appropriate per the World Bank; in the absence of established World Bank testing methodologies, US EPA Source Test Sampling and Analysis Methods shall be used.

Equipment-specific performance criteria presented in Table 3 are based on the size, model, relative location, operating schedules, and fuel type assumed in the Design Basis for this project. The Contractor's design of permanent facilities, including facility layout (equipment location, orientation, and building size/configuration) shall not differ substantially from facility design assumed in the Design Basis without written approval received from ESSO.

**Table 2
 World Bank Ambient Air Quality Criteria**

Parameter	Maximum Level
Particulate Matter (<10µm) Annual Arithmetic Mean Maximum 24-hour Average	100 µg/m ³ 500 µg/m ³
Nitrogen Oxides, as NO ₂ Annual Arithmetic Mean Maximum 24-hour Average	100 µg/m ³ 200 µg/m ³
Sulfur Dioxide Annual Arithmetic Mean Maximum 24-hour Average	100 µg/m ³ 500 µg/m ³

Source: The World Bank Environment, Health and Safety Guidelines, Onshore Oil and Gas Development (World Bank, 1995)

Changes shown by ⇒


Table 3. DESIGN PARAMETERS FOR AIR EMISSIONS MODELING

EQUIPMENT TYPE	EQUIPMENT SIZE		EMISSION RATE ⁽¹⁾				STACK HEIGHT ⁽²⁾		EXHAUST GAS TEMPERATURE ⁽³⁾			EXHAUST GAS FLOW RATE ⁽⁴⁾	
			NO _x	PM	SO ₂		(ft)	(m)	(K)	(F)	(C)	(ft ³ /s)	(m ³ /s)
PUMP STATIONS													
Main Pump Diesel Engines	6000	HP	12.1	0.63	0.51	g/HP-hr	50	15.24	644	700	371	393	11
Generator Diesel Engines	1000	HP	12.1	0.63	0.51	g/HP-hr	50	15.24	644	700	371	98	3
Fired Heater	98	MBtu/hr	135	55.4	66.3	g/MBtu	125	38.1	561	550	288	894	25
DOBA OPERATIONS CENTER													
Flare	14000	m ³ fuel/hr	30.9	9.2	~0 ⁽⁵⁾	g/MBtu	50	15.24	1272	1830	999	10,000	283
Crude Oil Topping Plant Fired Heater	11.2	MBtu/hr	135	55.4	66.3	g/MBtu	30	9.15	561	550	288	397	11
Turbines	33,000	HP	2.97	0.34	0.63	g/HP-hr	35	10.66	767	921	494	1782	50
Incinerator	3,455	tonne/year	3005	917	1084	g/tonne	20	6.10	380	225	107	125	4

(1) Values shown are maximum allowable emission rates. Incinerator emission rates are based on the following waste percentage and heat content values (where waste classifications are as defined in the Waste Incinerator Specification).

Waste Classification	%	Heat Content (Btu/lb)
Type 0	2.30	8500
Type 1	1.60	6500
Type 2	0.40	4300
Type 3 & 4	0.05	2500
Type 5	44.75	18000
Type 6	50.90	18000

- (2) Values shown are minimum allowable stack heights.
- (3) Exhaust temperatures should not differ from degrees Fahrenheit values presented by more than 10%.
- (4) Exhaust gas flow rates should not differ from values presented by more than 20%.
- (5) Expected to be very low because of the fuel source, assume no control measures are needed.

ESSO EXPLORATION & PRODUCTION CHAD INC.  SPECIFICATION	ENVIRONMENTAL IMPACT MITIGATION	CCS 21-20-108	
		Page 7 of 22	
		Rev. 1	Oct. 1997

Changes shown by ⇒

6.0 Soil Protection Mitigations

6.1 Soil Erosion Mitigations

Contractor shall take actions necessary to prevent erosion from occurring as a result of construction activities. Minimum standards and mitigation measures are included in the Soil Erosion Mitigation Specification. This specification applies to all Work Site areas including borrow pits/areas, storage and laydown areas, camps, and access roads.

6.2 Spill Remediation Standards

6.2.1 Hydrocarbons

In the event of a spill of a hydrocarbon based product, Contractor shall bring all soil containing over one weight percent hydrocarbon to the surface (top 30 cm or less) for remediation or disposal.

Soil containing over five weight percent hydrocarbon shall either be mixed in place to less than five weight percent total hydrocarbons or shall be removed to an ESSO approved treatment or disposal site.


Soil shall be treated to below one weight percent hydrocarbon (as measured using a test method accepted by ESSO).

If selected as the remediation method, in-place bioremediation of the product shall be initiated by using the following steps:

- Add slow release fertilizer at a rate of 1 kg urea per 10 m² and 0.5 kg of triple superphosphate per 10 m² (alternate forms of nitrogen and phosphorous may be used with ESSO's approval). If run-off from the site could impact nearby streams or sensitive vegetation, the level of fertilizer should be reduced by an amount appropriate for the distance to the receptor.
- Till in fertilizer
- Water, if practical, to initiate biodegradation process (target: 70% of the soil's water holding capacity).

6.2.2 Acids and Bases

In the event of a spill of materials with a pH more than 2 units above or below native soil pH, Contractor shall neutralize the affected soils, adjusting the pH to that of native soil in the area.

ESSO EXPLORATION & PRODUCTION CHAD INC.  SPECIFICATION	ENVIRONMENTAL IMPACT MITIGATION	CCS 21-20-108	
		Page 8 of 22	
		Rev. 1	Oct. 1997

Changes shown by ⇒

6.2.3 Miscellaneous Materials

Hydraulic fluid, anti-freeze, solvents and other specialty fluids used on the construction site should be selected so that impacts are minimized in the event of a release (e.g. using less toxic versions of these products). Characteristics of the product will determine the appropriate treatment/disposal action and the concentration of product that could be left in the site soil without significant impact. Spill response and remedial actions shall be approved on a product-by-product basis by ESSO as per the requirements of Section 30 of the Coordination Procedure.

7.0 Water-body and Wetland Protection Measures

7.1 Equipment Operation and Refueling

Where mobile equipment is required to operate and refuel within 30 meters of a water-body or wetland, the following measures shall be employed by Contractor to minimize the risk of fuel spills into the water-body:


- (i) ensure that all containers, hoses and nozzles have no leaks;
- (ii) ensure that pumps have operational emergency shut-off switch;
- (iii) ensure that nozzles are equipped with automatic back flow shut-off switches;
- (iv) where fueling must be performed within this area, operators shall be stationed at both ends of the hose unless the ends are visible and are readily accessible by one operator;
- (v) fuel remaining in the hose shall be returned to the storage facility; and
- (vi) sorbant boom or similar material capable of capturing oily substances from the surface of the water shall be placed so that any released materials shall be absorbed or contained for subsequent recovery.

7.2 Vehicle Crossings

Contractor shall install and maintain vehicle crossing structures such as temporary bridges at watercourses so that no machinery need ford a watercourse except as otherwise provided in 9.4.1.

8.0 Control of Work Site Disturbance Area

Work Site access shall be restricted to existing roads, railroads, additional road right-of-way provided by ESSO, waterways designated by ESSO and ESSO provided pipeline right-of-way, storage and laydown areas, and permanent facilities sites.

<p>ESSO EXPLORATION & PRODUCTION CHAD INC.</p>  <p>SPECIFICATION</p>	<p>ENVIRONMENTAL IMPACT MITIGATION</p>	<p>CCS 21-20-108</p>	
		<p>Page 9 of 22</p>	
		<p>Rev. 1</p>	<p>Oct. 1997</p>

Changes shown by ⇒

Contractor shall take the following measures to control the Work Site:


- a) Work activities, project-related vehicle traffic, and equipment storage shall be restricted to approved roads, designated access roads, pipeline right-of-way, storage areas, staging and parking areas, and other Work Site areas;
- b) Contractor shall not construct any roads without prior approval from ESSO;
- c) All traffic safety and road closure regulations shall be followed;
- d) Off-road traffic outside of designated areas shall be prohibited;
- e) Project-related vehicles shall observe a 30 kilometer per hour maximum speed limit on the Work Site. The 30 kilometer per hour maximum speed limit applies to congested work areas and camps. Contractor shall apply judgment, such as Job Safety Analysis (including factors such as dust, population and environment) to determine safe speeds for other areas;
- f) Parking, storage, and general Work Site areas shall be designated by flagged stakes. These areas shall be established in locations disturbed by previous activities, to the extent possible;
- g) Pipeline right-of-ways shall be clearly marked at their centerline and outside boundaries, prior to construction;
- h) Construction shall be limited to daylight hours;
- i) Unauthorized public use of the Work Site areas and non-public access roads shall be minimized by placement of physical barriers and signs (with English, French and pictorial representations of the messages); and
- j) Unless specified by ESSO, temporary roads and Work Site areas shall be removed, and the surface reclaimed as described below, when they are no longer needed for the Work. Restoration of temporary access roads shall require the planting of trees or placement of other barriers to prevent vehicular access. Clean-up and reclamation shall be completed as quickly as practical following completion of Work activities in Work Site areas.

9.0 Mitigation of Construction Related Impacts

9.1 Clearing

Cleared areas include pipeline right-of-way, sites for facilities construction, access roads, storage and laydown areas, camps, and other related Work Site areas.

Contractor shall clear only the areas required for construction and operations as approved and specified by ESSO. ESSO may identify trees and other objects to be preserved depending upon size and location of the area to be cleared. Contractor shall mark vegetation, trees and other objects that are to remain and shall protect these items from damage. The disposition of trees that must be

ESSO EXPLORATION & PRODUCTION CHAD INC.  SPECIFICATION	ENVIRONMENTAL IMPACT MITIGATION		CCS 21-20-108	
			Page 10 of 22	
	Rev. 1	Oct. 1997		

Changes shown by ⇒

felled shall be as specified below. Contractor may use timber cut on Work Site areas in its construction work (provided appropriate fees are paid to the Government), but shall not cut timber located off the Work Site.

Brush and trees shall be felled parallel to or back toward the area to be cleared in order to minimize damage to structures and trees on adjacent property. Grubbing of root stock and stumps shall be done only where necessary to maintain unobstructed access or protect the installation.

Unless specified otherwise by ESSO, Contractor shall manage and dispose of trees, brush, stumps and limbs in the following manner:

- (i) identify, limb and segregate all trees of commercial value;
- (ii) cut up and neatly stack lesser materials into manageable pieces for use by local inhabitants (not requiring more than two people to carry, and no longer than three (3) meters);
- (iii) upon approval of ESSO, lesser materials may be processed through a chipper for use as bulking agent for land treatment, composting or distribution over cleared areas during site restoration (mulching).

⇒ Burning of vegetation shall be minimized to the maximum extent feasible.


9.2 Grading

Grading by Contractor shall be limited to that area necessary to permit movement and operation of equipment. Removal of soil seed-banks (topsoil) shall be done in advance of grading or trenching in order to prevent unnecessary delays. Graded material from the right-of-way shall be stockpiled in the cleared portion of the right-of-way for use during backfill and cleanup. Topsoil removal, storage and reuse shall be as described in the Soil Erosion Mitigation Specification.

Grading by Contractor shall preserve the existing natural drainage topography as nearly as practicable. When terraces, levees, and other such facilities are cut, Contractor shall leave them open only as long as necessary for the Work and restore them to their original state as promptly as practical.

Grading shall not be allowed in riparian areas/stream crossings within 24 hours of significant precipitation.

Contractor shall avoid the formation of continuous rows of spoil or lengths of open trench that interfere with the passage of livestock and vehicles across the Work Site. Gaps shall be left in the rows of spoil at ESSO-designated intervals

ESSO EXPLORATION & PRODUCTION CHAD INC.  SPECIFICATION	ENVIRONMENTAL IMPACT MITIGATION	CCS 21-20-108	
		Page 11 of 22	
		Rev. 1	Oct. 1997

Changes shown by ⇒

and to coincide with fences, water courses, access tracks, obvious livestock routes, etc.


Stockpiled topsoil or backfill shall be stored above the stream high water mark, outside any riparian zone, and not in any area where the material could be easily washed back into the stream. The boundaries of unsuitable areas for stockpiling material at stream crossings shall be marked by Contractor's environmental monitors in consultation with its construction crews. Potential erosion into a stream of stockpiled material or soil from the exposed bank shall be prevented by rows of hay bales or available equivalent along the bank. The bales shall be placed at flowing river or creek crossings at the end of each work day during the rainy season, or any other day when rain is forecast. Stockpiled topsoil or spoil shall not be exposed near a stream channel or riparian area for more than 30 days.

Excess material removed from graded areas shall be stockpiled within the cleared area of the Work Site. After construction it shall be replaced as closely as possible to its original location.

9.3 Hydrostatic Testing

When Contractor's scope of Work includes hydrotesting of installed facilities, Contractor shall develop a hydrotest plan for approval by ESSO. Hydrotest protocols shall conform with the Hydrostatic Testing Specification and the following practices:

- a) Disposal of the hydrotest water shall conform with Contractor's approved Waste Management Plan. Preferred locations for discharge of water will be onto soil (e.g., into infiltration beds or percolation ponds) rather than into water courses.
- b) When taking on hydrotest water from a watercourse, the intake hose shall be screened to prevent entrainment of fish and other aquatic life. Adequate flow rates must be maintained in the watercourse to protect aquatic life, provide for all water-body uses, and provide for downstream withdrawals of water by existing users (no more than ten (10) percent of the watercourse flow may be diverted to hydrotest use).
- c) Hydrostatic test manifolds shall be located outside wetlands and riparian areas to the maximum extent practicable.
- d) Where surface waters with potential biological pathogens are used as the hydrotest water source, Contractor shall take measures to prevent the exposure of workers to these pathogens in the event of a hydrotest leak.
- e) Contractor shall regulate discharge rate and use energy dissipation device(s) in order to prevent erosion, stream bottom scour, suspension of

<p>ESSO EXPLORATION & PRODUCTION CHAD INC.</p>  <p>SPECIFICATION</p>	<p>ENVIRONMENTAL IMPACT MITIGATION</p>	<p>CCS 21-20-108</p>	
<p>Page 12 of 22</p>			
<p>Rev. 1</p>		<p>Oct. 1997</p>	

Changes shown by ⇒

sediments, and excessive stream flow. Test water may need to be discharged into a filter bag, hay bale or silt fence containment structure to remove contaminants and sediments from within the pipeline prior to discharge.

- f) Contractor shall sample the test water during discharge to verify the absence of significant oil and grease or other pollutants

9.4 Water-body Crossings

It is assumed that pipelines are the only facilities that will cross water-bodies, and that pipelines will be buried. Therefore, the following text is written in the context of a buried pipeline. If other facilities cross water bodies, the intent of this section shall apply to their installation as well.

9.4.1 General Crossing Procedures

Construct crossings as close to perpendicular to the axis of the water-body channel as engineering and routing conditions permit.

Adequate flow rates must be maintained to protect aquatic life, provide for all water-body uses, and provide for downstream withdrawals of water by existing users.

Construction equipment (except that used by clearing crews) must cross water-bodies on bridges consisting of one of the following:


- a. Equipment pads and culvert(s);
- b. Clean rock fill and culvert(s); or
- c. Flexi-float or portable bridge.

⇒

If clearing or grading equipment must cross water-bodies prior to installation of equipment bridges, crossings shall be limited to the maximum extent feasible.

Contractor shall limit use of equipment operating in the water-body to that needed to construct the crossing.

Contractor shall limit the size of the crossing and adjacent impacted area to the minimum necessary for passage of the trench and associated equipment.

ESSO EXPLORATION & PRODUCTION CHAD INC.  SPECIFICATION	ENVIRONMENTAL IMPACT MITIGATION	CCS 21-20-108	
		Page 13 of 22	
		Rev. 1	Oct. 1997

Changes shown by ⇒

Contractor shall attempt to complete trenching and backfill work within the water-body (not including blasting) within 48 hours, unless site-specific physical conditions make completion within 48 hours impractical.

9.4.2 Equipment Bridges

All equipment bridges shall be designed to withstand the maximum flow and maintained to prevent flow restriction during the period the equipment bridge is in place.

Unless otherwise instructed by ESSO, remove all flue, dams and equipment bridges after final cleanup and grading but prior to completion of initial permanent seeding (if seeding is required).

Where appropriate alternative access is available to the applicable parts of the Work Site, equipment bridges shall be removed if there will be more than 1 month between final cleanup and grading and the beginning of initial permanent seeding (if seeding is required).

Consistent with the availability of reasonable alternative access, temporary bridges across water-bodies shall be removed at the earliest time practical to minimize impacts.

9.4.3 Temporary Erosion and Sediment Control


Contractor shall comply with the requirements of the Soil Erosion Mitigation section of this specification in order to minimize impacts to watercourses. Contractor shall also implement the additional measures to control sediment loading in water-bodies as described here.

Install and maintain, in proper working order, temporary sediment filter devices adjacent to all water-bodies in the vicinity of disturbed soil.

Use trench plugs at all non-flumed water-body crossings to prevent diversion of water into upland portions of pipeline trench during construction.

Dewater the trench in such a manner that no heavily silt-laden water flows into any water-body.

Install permanent slope breakers and trench breakers at base of all slopes adjacent to water-bodies.

ESSO EXPLORATION & PRODUCTION CHAD INC.  SPECIFICATION	ENVIRONMENTAL IMPACT MITIGATION	CCS 21-20-108	
		Page 14 of 22	
		Rev. 1	Oct. 1997

Changes shown by ⇒

9.4.4 Bank Stabilization and Revegetation

Limit use of rip-rap to areas where flow conditions preclude effective vegetative stabilization, unless otherwise specified by ESSO.

9.4.5 Maintenance

Allow a riparian strip at least 5 meters wide, but preferably 8 or more meters wide, as measured from the water-body's mean high water mark to permanently revegetate with native woody plant species across the entire right-of-way. However, to facilitate periodic pipeline corrosion/leak surveys, a corridor centered on the pipeline up to 3 meters wide may be maintained in an herbaceous state. In addition, trees that are located within 5 meters of a pipeline and are greater than 5 meters in height may be selectively cut and removed from the right-of-way.

9.5 Wetland Crossings

It is assumed that pipelines are the only facilities that will cross wetlands, and that pipelines will be buried. Therefore, the following text is written in the context of a buried pipeline. If other facilities cross wetlands, the intent of this section shall apply to their installation as well.

9.5.1 General Procedures

The only access roads other than the construction right-of-way which shall be used in wetlands are those existing roads that can be used with no modification and no impact on the wetland.


Contractor shall limit the size of the crossing and adjacent impacted area to the minimum necessary for passage of the trench and associated equipment.

Do not locate above-ground facilities in any wetland.

9.5.2 Crossing Procedures

Avoid wetland areas to the maximum extent practicable. If a wetland cannot be avoided or crossed by following an existing right-of-way, route the pipeline in a manner that minimizes disturbance to wetlands.

Minimize the duration of construction-related disturbance within wetlands to the maximum extent practicable.

ESSO EXPLORATION & PRODUCTION CHAD INC.  SPECIFICATION	ENVIRONMENTAL IMPACT MITIGATION		CCS 21-20-108	
			Page 15 of 22	
	Rev. 1	Oct. 1997		

Changes shown by ⇒

Limit the width of the construction right-of-way to the minimum required for passage of the trench and associated equipment.

Limit pulling of tree stumps and grading activities to directly over the trenchline. Do not grade or remove stumps or root systems from the rest of the right-of-way in wetlands unless the ESSO Inspector determines that safety-related construction constraints require removal of tree stumps from under the work-pad.


Construction equipment operating in wetland areas shall be limited to that needed to dig trench, install pipe, backfill trench, and restore the Work Site. All other construction equipment shall use access roads located in upland areas to the maximum extent practicable. Where use of access roads in upland areas cannot provide appropriate access, all other construction equipment may pass through the wetland once, using the right-of-way.

If standing water or saturated soils are present, use low-ground-weight construction equipment, or operate normal equipment off of timber mats, rip-rap, prefabricated equipment mats, or geotextile fabric overlain with gravel fill. Geotextile fabric use for this purpose must be flexible and strong enough to allow removal of all gravel fill and fabric from the wetland during the clean-up phase.

Do not use dirt, rock fill, tree stumps, or brush to stabilize the Work Site in wetlands.

Attempt to use no more than two layers of timber rip-rap to stabilize the Work Site. In the event that more than two layers of timber rip-rap must be used due to site-specific construction constraints, the following information must be provided as specified at the beginning of these Procedures.

- a) Contractor shall explain why alternative construction methods that do not involve the use of timber rip-rap (e.g., prefabricated equipment pads, low-ground-weight equipment) cannot be used in these areas;
- b) A detailed plan which addresses the procedures to be used to remove all timber rip-rap, specific measures (including the import of additional fill material) to restore pre-construction surface contours, and specific measures (including the planting of herbaceous and shrub species) to ensure successful revegetation of the construction right-of-way with native wetland plant species within 3 years after construction.

<p>ESSO EXPLORATION & PRODUCTION CHAD INC.</p>  <p>SPECIFICATION</p>	<p>ENVIRONMENTAL IMPACT MITIGATION</p>	<p>CCS 21-20-108</p>	
<p>Page 16 of 22</p>			
<p>Rev. 1</p>		<p>Oct. 1997</p>	

Changes shown by ⇒

Remove all timber mats, rip-rap, prefabricated equipment mats, and geotextile fabric overlain with gravel fill upon completion of construction.

Assemble pipeline in upland area and use "push-pull" or "float" techniques to place pipe in trench where water and other site conditions allow.

9.5.3 Spoil Pile Placement and Erosion Control

Contractor shall comply with the requirements of the Soil Erosion Mitigation Specification in order to minimize impacts to wetlands. Contractor shall also implement the additional measures to control sediment loading in wetlands as described here.

Contractor shall place all spoil from water-body crossings, and wetlands crossings at least 3 meters away from water's edge, as a minimum, and shall contain spoil within sediment filter devices. Where the extent of the wetland makes placement away from the water's edge impractical, Contractor shall place spoil in areas where impact will be minimal and control water flow in the area with sediment filters.

Contractor shall install and maintain, in proper working order, temporary sediment filter devices adjacent to all wetlands in the vicinity of disturbed soil to avoid sediment flow into wetlands.

Contractor shall install and maintain in proper working order permanent slope breakers and trench breakers near the boundary between wetlands and adjacent disturbed upland areas to avoid sediment flow into the wetland.


When dewatering trench, Contractor shall discharge the water in such a manner that no heavily silt-laden water flows into any wetland.

9.5.4 Wetlands Restoration

Where the pipeline trench may drain a wetland, Contractor shall construct trench breakers and/or seal the trench bottom as necessary to maintain the original wetland hydrology.

Do not use fertilizer or lime within wetlands.

Restore surface contours and topsoil as required by the Surface Restoration and Site Reclamation sections, above.

ESSO EXPLORATION & PRODUCTION CHAD INC.  SPECIFICATION	ENVIRONMENTAL IMPACT MITIGATION	CCS 21-20-108	
		Page 17 of 22	
		Rev. 1	Oct. 1997

Changes shown by ⇒

9.5.5 Maintenance Practices

Vegetation maintenance practices over the full width of the permanent right-of-way in wetlands are prohibited. However, to facilitate periodic pipeline corrosion/leak surveys, a corridor centered on the pipeline up to 3 meters wide may be maintained in a herbaceous state. In addition, trees that are located within 5 meters of the pipeline and are greater than 5 meters in height may be selectively cut and removed from the wetland.

10.0 Surface Restoration


10.1 Pipeline (and Other Buried Facilities) Right-of Way

Following backfill of trench, the disturbed portion of the Work Site shall be returned to natural contours by Contractor where possible. Re-contouring to natural lines and grade shall be accomplished without disruption to adjacent undisturbed habitat. The area shall be compacted sufficiently to minimize erosion or excessive future settlement. Permanent water breakers and/or terraces shall be constructed on sloping ground to prevent erosion as specified in the Soil Erosion Mitigation Specifications. Natural drainage patterns shall be restored and in potentially high erosion areas (such as the banks of water courses) earth-filled sacks, stone rip-rap or other stabilization methods shall be used to ensure that the soil does not wash out before becoming consolidated. All restoration activities other than foot traffic shall be limited to previously disturbed portions of the Work Site.

When restoring disturbed right-of-way, Contractor shall:

- use clean, efficient construction techniques to minimize short term disruptions and prevent long term degradation of the environment;
- restore all banks of watercourses, hills and steep slopes to as near their original condition as practical;
- properly rip-rap and terrace banks and slopes to control erosion;
- restore terraces, levees and drainage ditches to as near their original conditions as practical;
- clean-up the right-of-way immediately following the backfill of the trench; and
- remove spoil, debris, piling, cofferdams, and false-work from watercourses to prevent interference of the normal water flow and watercourse use.

Watercourses disturbed by construction of the pipeline (or other buried facility) shall be opened across the right-of-way and trenched for the proper flow of water. Furrows and terraces shall be constructed across the right-of-way as

ESSO EXPLORATION & PRODUCTION CHAD INC.  SPECIFICATION	ENVIRONMENTAL IMPACT MITIGATION	CCS 21-20-108	
		Page 18 of 22	
		Rev. 1	Oct. 1997

Changes shown by ⇒

necessary to divert the flow of water away from the backfilled trench and into natural drainage courses to prevent excess erosion along the facility.

Contractor shall replace the soil from side hill cuts as directed by ESSO. All side hill cuts and fills shall be sloped sufficiently to prevent injury to personnel, livestock, and wildlife and to prevent erosion.


Topsoil shall be spread over cleared areas once any re-grading or deep ripping of compacted areas is complete in accordance with the Soil Erosion Mitigation Specification. Chipped vegetative debris may be mixed with the topsoil and spread over cleared areas. Contractor shall evenly spread topsoil over the right-of-way to restore the natural contour of the ground and allow normal surface drainage.

Where disturbed right-of-way passes across watercourses or through marshland, Contractor shall provide, place, and compact all fill material necessary to restore waterway and marshland banks to natural lines and grades or to the lines and grades specified on the drawings. Fill material shall be environmentally compatible with existing bank material to ensure consistency in vegetative growth. Where required by the drawings and/or specified in the Soil Erosion Mitigation Specification, Contractor shall utilize soil and bank stabilization to prevent bank slough and wash and to enhance vegetation growth.

10.2 Camps, Laydown Areas, Temporary Access Roads

Unless ESSO has specified that an area or a part of an area of the Work Site used during the construction phase of the project will also be needed for the operations phase, all affected areas shall be restored by Contractor. These areas (camps, laydown areas and storage yards, temporary access roads, fabrication areas, etc.) shall be returned to natural contours where possible. Re-contouring to natural lines and grade shall be accomplished without disruption to adjacent undisturbed habitat. If these areas have been compacted during use, they shall be scarified to loosen the soil.

Permanent water breakers and/or terraces shall be constructed across areas of sloping ground to prevent erosion as specified in the Soil Erosion Mitigation Specification. Natural drainage patterns shall be restored and, in potentially high erosion areas, earth-filled sacks, stone rip-rap or other stabilization methods shall be used. All restoration activities other than foot traffic shall be limited to previously affected areas and marked construction zones.

ESSO EXPLORATION & PRODUCTION CHAD INC.  SPECIFICATION	ENVIRONMENTAL IMPACT MITIGATION	CCS 21-20-108	
		Page 19 of 22	
		Rev. 1	Oct. 1997

Changes shown by ⇒

Contractor shall replace the soil from side hill cuts on the Work Site as directed by ESSO. All side hill cuts and fills shall be sloped sufficiently to prevent injury to personnel, livestock, and wildlife and to prevent erosion.

Topsoil shall be spread over cleared areas once any re-grading or deep ripping of compacted areas is complete. Contractor shall evenly spread topsoil over the area to restore the natural contour of the ground and allow normal surface drainage. Flat areas and slopes up to 3(H):1(V) grade shall be loose and friable to a depth of at least 120 millimeters. Compacted Work Site soils shall be loosened on the surface by scarifying (raking, disking, or other acceptable means). Slopes steeper than 3(H):1(V) shall have at least 70 millimeters of loose, friable, surface soil.


10.3 Borrow Pits/Areas

When borrow pits/areas will no longer be needed, the site shall be graded to ensure that it will not accumulate standing water or divert the flow of watercourses that may engulf it. If tracks were cut into river/stream banks, they shall be reinstated and measures take to prevent erosion, as necessary. The sides of the pits/areas shall be sloped sufficiently to prevent injury to personnel, livestock, and wildlife and to prevent erosion.

The reclamation provisions (including topsoil conservation and replacement) described in this specification for other Work Site areas shall also apply to borrow sites.

11.0 Site Reclamation

All areas not under permanent facilities shall be restored to an equal or better soil condition than when disturbance occurred so that the pre-disturbance vegetation type can re-establish itself in a short period of time. In order to facilitate revegetation, mitigations that may apply for reclamation of portions of the Work Site include fertilizing and seeding, mulching, and surface texturing. Locations where one or more of these techniques will be required to facilitate revegetation shall be identified in the field by ESSO and Contractor environmental monitors (or other qualified personnel approved by ESSO). Close attention shall be paid to areas where erosion potential is high (e.g. at the crossings of watercourses, areas of the Work Site that are seen to be subject to active erosion, etc.), and where unauthorized access to the Work Site needs to be actively discouraged (e.g. where the Work Site passes through relatively undisturbed vegetation and intersects a road or track). Large plots of land such as storage yards, borrow pits and main camp sites shall be actively revegetated.

ESSO EXPLORATION & PRODUCTION CHAD INC.  SPECIFICATION	ENVIRONMENTAL IMPACT MITIGATION		CCS 21-20-108	
			Page 20 of 22	
	Rev. 1	Oct. 1997		

Changes shown by ⇒

11.1 Fertilization and Seeding

In disturbed Work Site areas with very little topsoil or naturally sparse vegetation, Contractor may need to fertilize with an N-P-K fertilizer at a loading rate suitable for new grass growth, and seed the area with an ESSO approved native seed mixture. In the absence of soil tests, 0.11 tonnes per hectare of 10-10-10 or equivalent fertilizer shall be used in these areas.

If seeding/planting of the area by Contractor is necessary, fertilizer shall be applied before seeding/planting and harrowed or disked uniformly into the soil to a minimum depth of 80 millimeters on slopes flatter than 3(H):1(V). On slopes steeper than a 3(H):1(V) grade, fertilizer shall be worked the best way possible.


If seeding/planting of the area is necessary, native seed mixtures or plants/sprigs used shall be compatible with local soil conditions and climatic zones, and shall be free of weeds. Seed shall be applied uniformly in a manner appropriate for the type of seed used, and shall be placed in a firm, moist seedbed to a depth suitable for the seed selected. Plants/sprigs shall be planted at a suitable density and in a manner conducive to successful growth.

Any seeded/planted area which fails to show a uniform stand of vegetation after one growing season shall be assessed to determine obvious causes for failure. The site shall then be reseeded/replanted, refertilized, remulched and/or reharrowed, as necessary, and/or the revegetation approach shall be modified to improve the chances of successful revegetation in the next growing season. A uniform stand of vegetation will be considered growth which shows no deterioration or bare spots greater than 1 square meter (10.76 ft²) in size and provides a minimum of 80 percent grown cover. Areas not satisfying this definition may be approved by ESSO as satisfactorily revegetated if Contractor can show that these areas are not significantly different from the surrounding environment (outside the project impacted area). One year after initial site reclamation, Contractor shall inform ESSO of the locations of all sites where vegetation is still below the target level so that ESSO may continue site reclamation efforts, as necessary.

11.2 Mulching

If mulching of an area by Contractor is necessary, the following types of mulches may be acceptable:

- Hay or other native pasture mixture, unrotted with a low moisture content, applied at a rate of 0.4-0.5 kg/m².
- Straw from wheat, oat, or rice (free of viable seed), unrotted with a low moisture content, applied at a rate of 0.5-0.7 kg/m².

ESSO EXPLORATION & PRODUCTION CHAD INC.  SPECIFICATION	ENVIRONMENTAL IMPACT MITIGATION	CCS 21-20-108	
		Page 21 of 22	
		Rev. 1	Oct. 1997

Changes shown by ⇒

- Wood cellulose fiber, applied at a rate of 0.17 kg/m².
- Stockpiled vegetation which has been chipped or shredded, applied at a rate of 0.5 kg/m².

On slopes greater than 3(H):1(V) prefabricated blankets (mats) of straw, coconut, wood or other natural plant fibers sewn together with a biodegradable netting may be used. Prefabricated blankets (mats) shall be stapled in place with No. 11 gauge wire staples 150 to 250 millimeters long. The staple pattern shall be in accordance with the manufacturer's recommendations.

Mulch shall be anchored immediately after mulch placement using one of the following methods as approved by ESSO:

11.2.1 Crimping


A notched, straight disk crimper set to push part of the broadcast mulch fiber 50 to 80 millimeters into the soil shall be used to anchor yet leave part standing upright.

11.2.2 Imprinting

Imprinting is expected to be the preferred method of surface soil/seedbed preparation on many of the disturbed portions of the project. Imprinting with a shaped roller is a cost effective practice that is well-suited for use on large portions of the Chad Development Project. The imprinter roller forms funnel shaped seedbed and seedling cradles which concentrate water and improve infiltration. At the same time, the imprinter provides simultaneous mulching of above ground plant material without topsoil inversion in a single operation. Because the surface roughness reduces wind-speed, sand deposition and the capture of wind blown seeds in the imprints are facilitated. Land imprinters generally use three basic tooth geometries to imprint conical, pyramidal or V-trough shaped funnels in the soil surface. When used in conjunction with seeding, seed shall be disseminated directly on top of the roller which allows the seed mix to be imbedded in the surface of the imprint.

11.2.3 Mulch binders/tackifiers

Mulch can be anchored by injecting tackifiers into the mulch stream as the mulch leaves the blower. Non-asphaltic tackifiers consisting of vegetable gum or silicate-based polymers blended with hydrophilic polymers may be used. These shall be applied using the manufacturer's recommended rates.

<p>ESSO EXPLORATION & PRODUCTION CHAD INC.</p>  <p>SPECIFICATION</p>	<p>ENVIRONMENTAL IMPACT MITIGATION</p>	<p>CCS 21-20-108</p>	
<p>Page 22 of 22</p>			
<p>Rev. 1</p>		<p>Oct. 1997</p>	

Changes shown by ⇒

11.3 Surface Texturing

It is expected that mitigation recommendations will include the use of an imprinter over much of the Work Site requiring restoration (including those areas where fertilizer and seed are not applied).