



HOSTED BY
WORLD BANK GROUP
Water

WASTEWATER REUSE CERTIFICATES AS TRADEABLE PERMITS: A HANDBOOK FOR ROLL-OUT

2030 WATER RESOURCES GROUP,
WORLD BANK GROUP



CHAPTER 1

The concept of
Wastewater Reuse
Certificates

CHAPTER 2

The WRC Ecosystem
and the key actors

CHAPTER 3

Implementation of WRC
in a geography

CHAPTER 4

Timeline for
implementation

ANNEXURES



Disclaimer

This work is a product of 2030 WRG with external contributions. The findings, interpretations, and conclusions expressed in this work do not necessarily reflect the views of the World Bank, its Board of Executive Directors, or the governments they represent. The World Bank does not guarantee the accuracy of the data included in this work. The boundaries, colors, denominations, and other information shown on any map in this work do not imply any judgment on the part of the World Bank concerning the legal status of any territory or the endorsement or acceptance of such boundaries.

Acknowledgements

This handbook has been developed by the 2030 Water Resources Group (2030 WRG), a global partnership platform hosted by the Water Global Practice of the World Bank.

The study was led by Rochi Khemka, Global Partnerships Coordinator and Senior Water Resources Specialist, 2030 WRG, and Mahesh Patankar, Senior Advisor, Disruptive Technologies, 2030 WRG, under 2030 WRG's global engagement on Disruptive Technologies and Water.

The team acknowledges the support of Sumouleendra Ghosh, Arghya Paul, Yagnesh Rohit, Sanhita Sharma, Biswadeep Biswas and Dr. Indra Mitra from KPMG India in the development of this document. The team also wishes to acknowledge the initial support it received in 2018 from the Maharashtra Water Resources Regulatory Authority (MWRRA), led by Mr. K.P. Bakshi; and inputs on the concept of wastewater reuse trading it received in 2019 from Mr. U.P. Singh, Secretary, Ministry of Jal Shakti, India. We acknowledge the support from Ajith Radhakrishnan (India Coordinator, 2030 WRG) and Sayef Tanzeem Qayyum (Bangladesh Coordinator, 2030 WRG) during the validation of the concept in the two countries.

We also wish to thank the following individuals for their invaluable peer review comments on the handbook: Diego Juan Rodriguez (Lead Economist, World Bank); Kristoffer Welsien (Senior Water Supply and Sanitation Specialist, World Bank); Daniel Nolasco (Nolasco & Assoc. Inc.); Dilip Limaye (Consultant, World Bank); Anna Delgado Martin (Consultant, World Bank); and Rajesh Nair (Consultant, 2030 WRG).

Objective of the Handbook

The Handbook aims to serve as a guide and dissemination tool for Wastewater Reuse Certificates (WRCs), a market-based mechanism conceptualized by 2030 Water Resources Group to enable circular economy solutions in the water sector. This Handbook is targeted at water sector experts, regulators, industry associations, and other stakeholders interested in supporting the adoption of the WRC system across geographies. It captures the conceptual framework and foundational elements for implementation of the WRC trading system – including the shortlisting and registration of users, setting reuse targets for the users, and promoting trade of WRCs between them. It also details the use of digital technology for data capture and validation, and trading, among other areas.





Executive Summary

Water is an important natural and economic resource for the sustenance of life and economic activity. Rising population, urbanization, and industrialization have all contributed to the increasing gap between demand and supply. It is, therefore, important to bring efficiency in use, given that water reserves are finite. Water supply is highly subsidized in most places and its true economic value is not reflected in its price, resulting in inefficient allocations and use. Further, greater use of water has led to the higher discharge of wastewater into rivers and run-offs, thereby increasing the extent and intensity of pollution of water bodies and water sources. The traditional linear approach of 'take-use-discharge' comes at a significant cost to the environment, societies, and economies. In fact, scarcity of water, and deterioration of its quality has emerged as one of the major risks to economies worldwide. Increasingly, a need to transition away from the traditional linear model and to embrace a circular economy model for water has been recognized. A circular economy follows the 3Rs approach: reduce, reuse, and recycle, where the resource use is minimized, reuse is maximized, and the resource is recycled to a high degree, thereby preserving, and restoring natural ecosystems and designing out waste and pollution.

There is growing recognition among citizens, governments, and regulators to devise policy responses that i) encourage efficiency in water use and ii) abate the pollution of water bodies. While conventional policy instruments e.g., compliance-based regulations (discharge norms, water entitlement allocations/ rationing), taxation, infrastructure creation (Wastewater Treatment Plants) are important and necessary, these alone are not sufficient to effectively meet the policy objectives. An alternative policy approach that can complement the compliance-based regulations and/ or taxation approaches is the cap-and-trade system. This system works by imposing a cap on the total units of pollution permitted into the environment, requires polluters to hold permits in proportion to their polluting needs, and allows trading of permits between polluters.

The 2030 Water Resources Group (2030 WRG), along with its partners, has conceptualized an innovative cap-and-trade policy instrument to promote wastewater reuse. The system is target-based and suitable for large water consumers such as large industries and industrial parks, urban local bodies, housing complexes and gated communities, and transfer of treated wastewater from urban to agriculture sectors. Under this system, a water reuse target is set for each user, and users that exceed their target earn credits in the form of Wastewater Reuse Certificates (WRCs).

Other users who are unable to meet their reuse targets can purchase WRCs from the market to cover their shortfall. 2030 WRG intends to dovetail financing approaches to encourage a higher level of investment in wastewater recycle and reuse projects.

The WRC scheme is driven by an Implementation Agency (e.g., regulator, in case of a regulated regime, or an anchor entity such as globally relevant and country-specific industry associations, in a voluntary regime). Under a regulated approach, water-guzzling users will be selected and notified to participate in the WRC scheme, with possible legal enforcement and punitive action for non-compliance. On the other hand, under a voluntary approach, large water users may join the scheme for increase in brand

value recognition, leading to higher shareholder and investor value creation. Additionally, for both regulated and voluntary approaches, there exists a possibility of linking the WRC issuance with attractive credit flows. To promote a higher level of WRCs to be captured, a pre-defined window of low-interest credit through financing facilitation could be thought of to create the market.

This Handbook describes a framework for implementation of this system (hereafter 'WRC system/ scheme') and discusses the various related aspects.

An enabling institutional framework is at the core of making the WRC system effective. The key institutional actors and their responsibilities for effective roll-out and implementation of the scheme are described in the figure below.

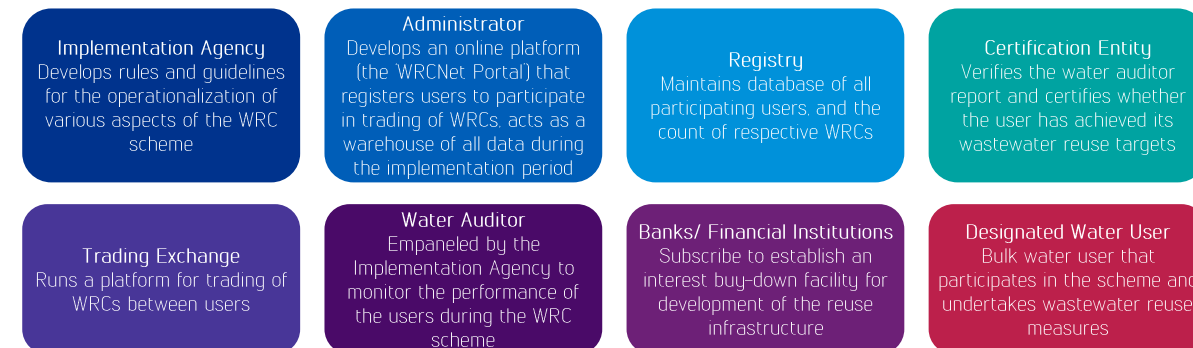



The institutional framework must inspire confidence among stakeholders, especially with respect to transparency and accountability.

The success of the roll-out and implementation of a concept like WRC requires sustained engagement with public agencies, regulators, industry stakeholders, subject matter experts, universities, not-for-profit organisations, and academicians to socialize the concept and secure their buy-in. The Implementation Agency shall develop operational guidelines and standard operating procedures, in consultation with key stakeholders, for each aspect of the WRC scheme.

Information on the institutional mechanism, and the operational guidelines must be made publicly available, to ensure transparency and inspire public confidence.

The implementation of the WRC system may be divided into control periods, each period spanning at least three years. The three-year period comprises a baseline year (1st year), a target year (2nd year) and an assessment year (3rd year). The implementation of the WRC system involves eleven steps, as indicated in the figure below and elaborated thereafter.

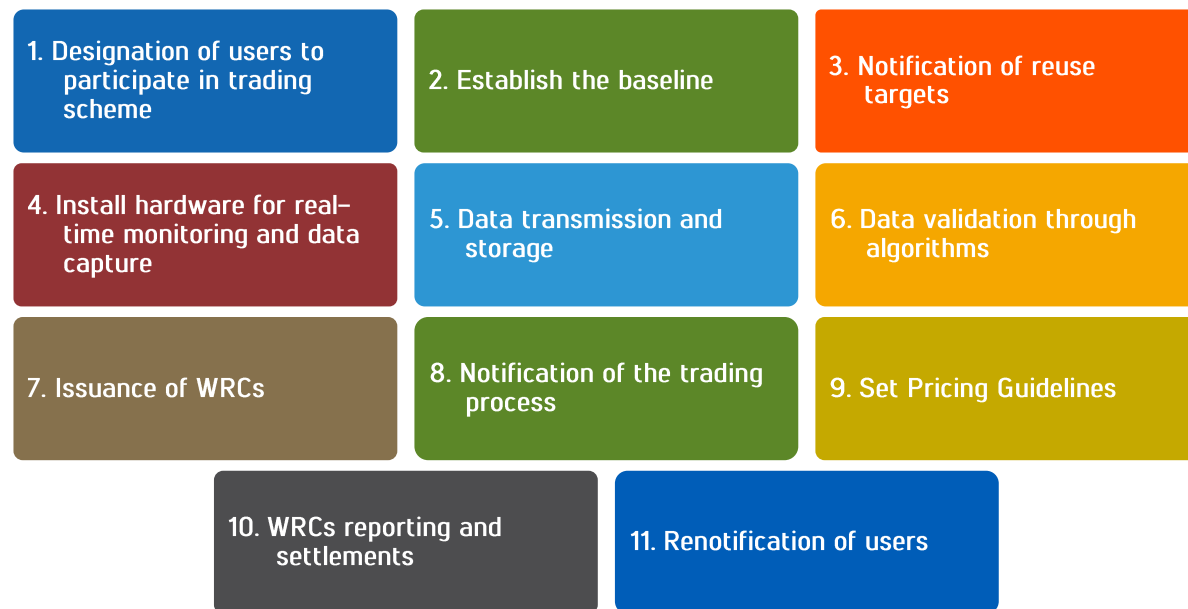

Step 1: Identification of users

To participate in the WRC scheme, large bulk water consumers should be identified across various sectors in a particular geography. The enrolment of users to the scheme should be done in a phased manner i.e., starting with the largest consumers initially and then moving on to include users with lower consumption in subsequent phases, to allow for a staggered expansion of the system. On notification of users for participation, users will be required to get registered on a web interface – the WRCNet Portal.

Step 2: Establish the baseline

Establishing the baseline involves assessing users' historical water consumption and water withdrawals from the environment over the past three/ five years. The baseline shall be estimated based on the activities within a defined operational boundary and shall be determined by an empaneled water auditor. The estimates shall be normalized after accounting for various factors that impact water consumption like capacity utilization (due to availability of fuel and raw material, force majeure conditions), product mix and intermediary product, fuel quality, raw material quality, addition of new line or unit, change in process technology, etc.

Step 3: Notification of reuse targets

The target setting exercise is undertaken on the principle that the industries, sub-industries, or users with high water withdrawals are assigned higher targets for incremental reuse vis-à-vis other industries, sub-industries, or users. The Implementation Agency will define an overall reuse target based on an assessment of the achievable potential for each sector and/ or industry. Thereafter, targets will be cascaded and distributed among sub-industries and users. At the level of a user, the Implementation Agency will depend upon the user's baseline to set a specific reuse target. The target is based on an assessment of creating additional recycling capacity that is cost-efficient, after considering theoretical, economic, and achievable reuse potentials for the user.

Step 4: Set up hardware for real-time monitoring and data capture

The performance of the users shall be monitored on a real-time basis through IoT based sensors and meters. The sensors and meters are to be mounted at the outlet where wastewater is generated, the inlet of the wastewater treatment plant, the inlet for treated wastewater for each user, and the point of discharge from the wastewater treatment plant into the environment. To facilitate uniform and robust monitoring, the Implementation Agency shall define the specifications of the user-installed sensors.



Step 5: Data transmission and storage

The installed meters and sensors will record and transmit data periodically to a central data warehouse. The data repository of the WRCNet Portal functions as a data lake for a large volume of data transmitted in real-time. Encryption protocols need to be defined for data capture and transmission, to ensure that the data is tamper-proof. The IoT hub of the WRCNet Portal executes unmarshalling of protocol wrappers or format translations to convert the data into canonical forms. This may include encryption/ decryption and URL-based data transfers, allowing for a change in the IP configurations, if required.

Step 6: Data checking using algorithms

A technology interface automatically checks for anomalous data, which may arise due to meter malfunction or treatment plant malfunction. The Implementation Agency, in consultation with the stakeholder ecosystem, shall develop rules of thumb (based on historical performance of the user or similar users) that will be used to flag anomalous data. The WRCNet Portal deploys these rule-based filtering of the data received by a stream filter technology to report any exception or

deviation from the acceptable range to the MIS dashboard. This will enable continuous data curation using IoT techniques, anomaly detection using machine learning, and artificial intelligence. Also, the use of tamper-proof distributed ledgers such as blockchains can promote transparency and reduce potential for fraud.

Step 7: Issuance of WRCs

The performance of each of the users is assessed based on the data monitored and stored, the data validation algorithms, the verification report prepared by user-engaged empaneled water auditors and the check-verification report, prepared by an empaneled water auditor who is engaged by the designated entity. After assessment of users' reuse performance through due process, users are issued WRCs that are linked to the quality and quantity of treated wastewater vis-à-vis the respective reuse target. For the treatment of wastewater to a higher grade, higher number of WRCs are to be issued. All WRCs issued to the water users shall be issued in electronic form and will be maintained on the WRCNet Portal.

Step 8: Notification of the trading process

All registered users will take part in the trading process by trading WRCs in an established marketplace or a trading exchange. The trading exchange should be message-driven, should have low end-to-end latency, should have proper encryption protocols, and should be easily maintained. During the trading window, the water users submit buy or sell bids on the Trading Exchange. The Trading Exchange processes the trades during the trading window, subject to availability of sufficient WRCs with the users.

Step 9: Set Pricing Guidelines

The price of WRCs shall be market-driven and shall be determined via double-sided auction and uniform pricing. Additionally, to avoid high price volatility, the Implementation Agency shall define floor and ceiling prices of WRCs.

Step 10: WRCs reporting and settlements

For each trading session, the Trading Exchange shall discover a Market Clearing Price (MCP) and a Market Clearing Volume (MCV). On discovering the MCP and MCV based on the double-sided closed

auction with uniform pricing principle, the transaction is processed, and the financial settlement is made through the bank accounts of the respective users.

Step 11: Re-notification of users

On completion of a three-year control period, the WRC scheme shall be evaluated to assess its effectiveness, whether the objectives have been met, and to identify the scope for improvement in the scheme design or implementation. Accordingly, the evaluation and recommendations shall be based on the following pillars – legal framework, institutional structure, achievement, scheme design, and degree of compliance. Further, in anticipation of the subsequent phases, the Implementation Agency shall explore increasing the number of participating water users.

The above steps described the stakeholders, processes, and systems for effective implementation of the WRC scheme.



TABLE OF CONTENTS

CHAPTER 1

The concept of Wastewater Reuse Certificates



CHAPTER 2

The WRC Ecosystem and the key actors



CHAPTER 3

Implementation of WRC in a geography



CHAPTER 4

Timeline for implementation



ANNEXURES

1. THE CONCEPT OF WASTEWATER REUSE CERTIFICATES



Setting the context

Today, the global economy is facing major uncertainty and risks from a decline in available quality and quantity of water. According to the United Nations' World Water Development Report 2020, nearly 25% of the global population faces economic water shortage¹ and nearly four billion people live in conditions of physical water scarcity for at least one month per year². Further, water scarcity, exacerbated by climate change, could cost countries as much as 6% of gross domestic product³, with the effects relatively more severe in warmer and drier regions, mostly in developing nations.

Globally, freshwater use has increased by nearly 500% over the period of 1901 – 2014, and freshwater use in OECD nations has increased by approx. 660%⁴. Demand for water is expected to increase over the next few decades, with increase

in population, industrialisation, and urbanisation. Moreover, on the supply side, water from groundwater aquifers and surface water sources is being withdrawn at rates higher than replenishment. The global renewable internal freshwater resources per capita has reduced by nearly 56% over the period of 1962 – 2014^{5,6}, and globally nearly 80%⁷ of wastewater is released to the environment without adequate treatment. With rising population and economic growth, water pollution is expected to increase over the next few decades, especially in low-income and lower middle-income economies⁸.

1. Economic water shortage refers to the lack of necessary infrastructure to access water (Source: UN-Water, 2014)
2. Alcamo, J. Doll, P., Henrichs, T., Kaspar, F., Lehner, B., Rosch, T., Siebert, S., 2003. Development and testing of the WaterGAP 2 global model of water use and availability. *Hydrological Sciences Journal* 48:317–337
3. aus der Beek, T., Flörke, M., Lapola, D. M., Schaldach, R., Voß, F., and Teichert, E. 2010. Modelling historical and current irrigation water demand on the continental scale: Europe. *Advances in Geoscience* 27:79–85 doi:10.5194/adgeo-27-79-2010
4. Flörke, M., Kynast, E., Bärlund, I., Eisner, S., Wimmer, F., Alcamo, J., 2013. Domestic and industrial water uses of the past 60 years as a mirror of socio-economic development: A global simulation study. *Global Environmental Change* 23: 144-156

5. Hannah Ritchie (2017) – "Water Use and Stress". Published online at OurWorldInData.org. Retrieved from: <https://ourworldindata.org/water-use-stress> [Online Resource]
6. Food and Agriculture Organization. AQUASTAT data
7. United Nations World Water Development Report, 2017
8. United Nations Environment Programme (UNEP). A Snapshot of the World's Water Quality: Towards a Global Assessment (UNEP, Nairobi, 2016)

The traditional linear approach of 'Take-Use-Discharge' is increasing pressure on the finite water resources, with severe economic, social, and environmental implications. With the high dependence of economic activities on depleting water resources, the linear approach adversely impacts economic growth and standard of living. According to a recent study by the World Bank Group, when BOD crosses 8 mg/L, growth in Gross Domestic Product (GDP) in downstream regions can be reduced by one-third, and in middle-income countries, GDP growth of highly polluted downstream regions can be reduced by half⁹. Additionally, the linear model has high environmental costs, with water pollution causing severe damage to ecosystems and biological diversity.

According to the water valuation framework¹⁰ defined by the World Business Council for Sustainable Development, the full economic value of water includes both financial costs for water supply services and societal costs associated with water use. Currently, there is a huge difference between the economic value and the

actual price of water billed to consumers, resulting in high degree of wastage and inefficiency in water use.

There is a need to move away from the linear approach to an approach where water retains its full economic value after each iteration of use and is returned to the system for reuse. Such a circular approach shall involve the following:

- Avoid use, by assessing water needs of activities and eliminating non-essential ones.
- Reduce use, by enhancing water-use efficiency and optimizing water allocations.
- Reuse and recycle water, by identifying suitable water-consuming activities, and
- Replenish sources, by returning treated wastewater back to aquifers or surface water sources, for subsequent use.

In recognition of these principles, there is a need to promote measures that ensure source sustainability, enhance water-use efficiency and increase recycle and reuse of treated wastewater¹¹.



9. Damania, Richard, Sébastien Desbureaux Aude-Sophie Rodella, Jason Russ, and Esha Zaveri. 2019. Quality Unknown: The Invisible Water Crisis. Washington, DC: World Bank. doi:10.1596/978-1-4648-1459-4. License: Creative Commons Attribution CC BY 3.0 IGO

10. 'Business guide to water valuation: An introduction to concepts and techniques', World Business Council for Sustainable Development, September 2013

11. Rodriguez, Diego J; Serrano, Hector Alexander, Delgado, Anna, Nolasco, Daniel and Saltiel, Gustavo. 2019. 'From Waste to Resource: Shifting paradigms for smarter wastewater interventions in Latin America and the Caribbean.' World Bank, Washington, DC.

About Wastewater Reuse Certificates

Many governments, both federal and state, across the world are taking steps to promote water-use efficiency and increase the recycling and reuse of treated wastewater. For instance, in India, many state governments have formulated policies on treated wastewater reuse and the central government is currently working towards the development of a national policy on treated wastewater reuse. In Bangladesh, the Water Resources Planning Organisation is drafting the Industrial Water Use Policy, which lays the vision for water reuse as the guiding principle for future industrial parks and special economic zones. Several policies, legislative actions, regulations, and directives have been introduced to promote wastewater reuse practices across the globe and few of these are discussed in Annexure 1.

Economic instruments for wastewater reuse

Conventionally, investments in reuse infrastructure have been financed by government through budgetary allocations using tax revenue (as discussed in Annexure 2). However, considering the typical constraints related to government financing of infrastructure projects, policymakers need to explore alternate financing strategies. Moreover, a compliance driven command-and-control mechanism, which accompanies such government financed project structures, has proven to be cost inefficient, with high costs of regulatory oversight. Hence, policymakers must explore putting a price on water pollution and over-exploitation of water resources through market-based instruments. Some of the measures to put a price on water pollution are discussed in Figure 1.

Figure 1: Approaches to put a price on pollution

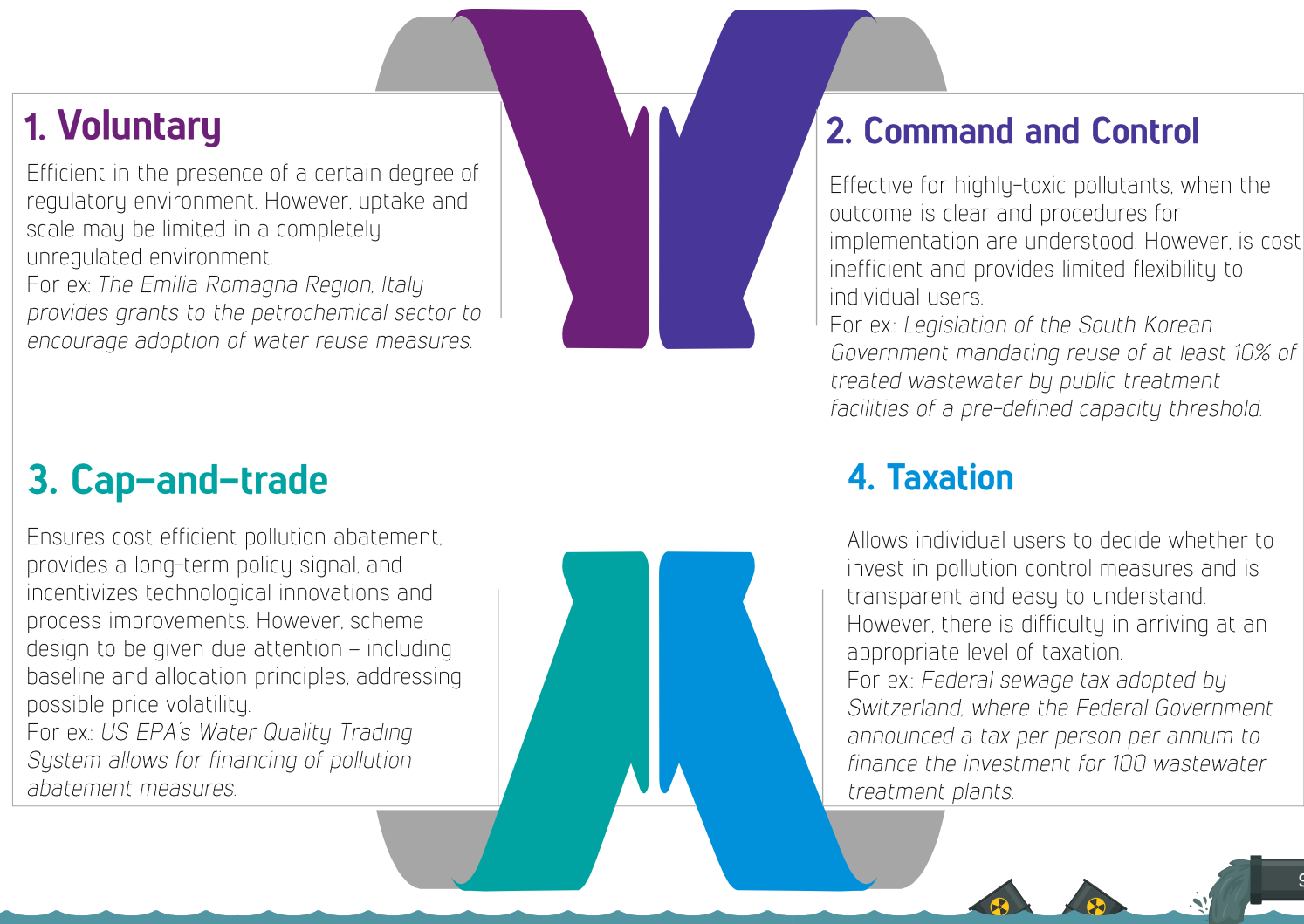

Taxing each unit of pollution has its benefits – it reflects the environmental damage caused by each unit of pollution and it is transparent and easily understandable. However, while taxation has its advantages, it suffers from disadvantages such as challenges in estimating an appropriate taxation level and challenges in ensuring global cooperation for a uniform taxation policy. Hence, there is a need for an intervention in line with common environmental principles, including polluters-pay principle, that grants polluters the flexibility in adopting water pollution abatement measures, encourages cost-efficient pollution abatement, drives investments in innovative solutions, and promotes technological advancements.

The cap-and-trade system falls under this category of instruments. Such systems encourage economical pollution abatement and incentivize innovations to improve environmental performance. Cap-and-trade systems have been designed and launched at a sub-national, national, and regional level, aiming to limit or cap pollutants (like CO₂ emissions control, improvement in air quality, water quality, etc.). An overview of some of these systems is provided in Annexure 22.

The cap-and-trade mechanism can also be adopted to promote wastewater reuse. The 2030 Water Resources Group (2030 WRG), along with its partners, has conceptualized such a market-based mechanism for the water sector with tradable

economic instruments called Wastewater Reuse Certificates (WRCs). This market-based mechanism encourages bulk water users to meet their regulatory requirements by overcoming the geographical constraints of the reclaimed water market.

About the WRC trading system

Under the WRC trading system, an independent Implementation Agency shall register water users across sectors, including municipal/ residential, industrial, and agricultural sectors, and set individual targets for wastewater reuse. These targets shall be user-specific and shall depend on the respective current water withdrawal from the environment and industrial best practices. This shall be promoted as a "Compliance Plus" mechanism, where the reuse targets are higher than the targets set by local regulations for water withdrawal and water pollution abatement.

Water users having marginal abatement costs lower than the price at which the WRCs are trading may exceed their targets and benefit by the issuance of WRCs. Each certificate is equivalent to a certain quantum of wastewater reused, i.e., 1 WRC ~ 1000 m³, and of a certain quality grade, as per the quality norms defined by the local regulator. Users that treat wastewater to a higher grade receive higher credits and WRCs, in proportion to the grade of treated wastewater.

The water users that are issued WRCs may sell them in the open market, allowing other water users to bridge the gap between their wastewater reuse target and achievement. The trading ensures that WRC price discovery is market-determined.

In this manner, each trading phase of the WRC scheme shall run over a three-year period. The first year (the baseline year) involves establishing the baseline for the respective users, followed by the target year, where the users undertake measures to achieve the reuse targets, and the final year (the assessment year) is when the performance of the users is assessed for issuance of WRCs and trading among users, if relevant.

For illustrative purposes, let us consider a market of two water users – User 1 and User 2. The current levels of wastewater reuse of both users, as a percentage of the respective total wastewater generated, is 20%. Let us assume that the Implementation Agency has set a wastewater reuse target of 35% for each of the users. Now, the users can achieve their targets by adopting wastewater reuse measures, adopting water efficiency measures or by purchasing treated wastewater from the water utility. As indicated in Figure 2, let us consider a scenario where User 1 has under-achieved its target, while User 2 has exceeded its target and is issued WRCs in proportion to the additional reuse achieved.

Figure 2: Structure of the trading mechanism for wastewater recycled

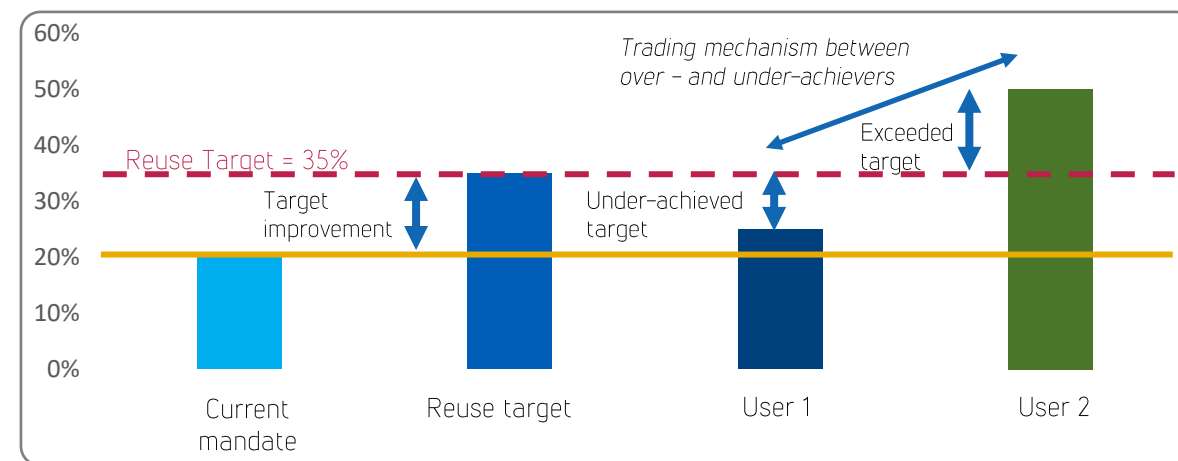



Thus, trading can take place between the two users – User 2 can sell its WRCs to User 1 at a market-determined price, and reuse targets can be met in the most cost-efficient manner.

With an increase in the number of users, the complexity of the trading system will increase; however, the underlying rationale remains unaffected.

Objectives of the WRC trading system

The WRC scheme has been conceptualized with the intention to:

- Maximize the use of wastewater treatment assets in the urban and industrial sector by enhanced and transparent data management on water quality, leveraging IT-enabled tools.
- Provide a thrust to wastewater recycling and reuse through specific targets for large urban local bodies and industries/ industrial parks, enhancing and complementing water conservation goals.
- Maximize financing for development through private sector participation and disruptive technologies to create water infrastructure for the Fourth Industrial Revolution (4IR).
- Promote relationships and partnerships with financial institutions to ensure availability of low-interest credit for development of reuse infrastructure.

- Create the right fiscal and institutional incentives through tradable permits, user rights, tariff incentives through regulatory structures, and
- Build institutional resilience and agility through IT-based innovations and multi-stakeholder platforms for supporting water sector reforms.

Features of regulated and voluntary regimes for WRC trading

To achieve the objectives, there are two variant implementation regimes that can be adopted:

- A regulated approach: An independent regulator of a country/ region/ geography will anchor the concept and enact regulations, select, and notify users, develop guidelines for target setting, support monitoring and verification, and issuance of the certificates. Here, users are selected and notified to participate in the WRC scheme; the regulator levies penalties on the user for not meeting its obligations, including the reuse targets set
- A voluntary approach: Region-specific industry associations or independent not-for-profit agencies will anchor and promote wastewater reuse practices among water guzzling industries, large private conglomerates, and urban local bodies. Here, the users may volunteer to participate in the scheme to avail debt at lower interest

rates for undertaking measures to meet their targets and for global recognition among various stakeholders and possible investors.

To implement the regulated approach in a specific geography, the pre-requisites include:

- Presence of enabling regulations on pollution control, wherein the regulator defines the discharge norms and compliance is enforced through the threat of penalties and other punitive actions.
- Presence of an appropriate tariff structure for purchase of water/ water withdrawal and a stringent penalty mechanism for non-compliance; and
- Robust governance structures, including the presence of an empowered regulator to notify water users to participate in a trading scheme, and penalize them for non-compliance.

Under a regulated approach, the policy framework, including acts and definitive legislations enforcing specific laws and regulations, must be robust. The federal or regional government, through legislative action, shall entrust statutory responsibilities to a public entity to promote wastewater reuse in the geography under its jurisdiction. The empowered entity may also underscore the criticality of wastewater reuse practices by enacting a dedicated Water and/ or Wastewater Policy.

In the absence of the above-mentioned pre-requisites, the voluntary approach, anchored by reputed industry associations or not-for-profits, may be explored. To promote higher level of reuse and investments in such projects and create a market for WRCs, a five-year window of low-interest credit through a financing facilitation would be useful. Learning from several such examples from other sectors such as energy, and low-income and affordable housing projects, the 2030 WRG intends to launch a financing facility to create a graded interest subsidy. The financing facility can be structured to provide graded interest rate subvention based on the number of created WRCs, where the higher the number of WRCs generated, the better would be the interest buy-down opportunity for the project developers and operators.

In fact, discussions are currently underway to roll-out both approaches in Asian geographies. The regulated approach is under consideration in Bangladesh, where the 2030 WRG is interacting with various policymakers to roll-out this concept in the industrial zones/ estates. For the launch of the voluntary mechanism, discussions are underway with key stakeholders in India and other parts of Asia.

Categories of bulk water users and the Business Cases

The WRC scheme may involve participation of different categories of water users, with individual reuse targets. Accordingly, the following four business cases are defined.

Case 1: Large industries and industrial parks

The large size of an industrial entity/company or a cluster of companies in industrial parks allows for an independent business case for WRC trading. Due to the nature of industrial effluent generated by each user and the industry-specific

good practices for reuse, the reuse targets are specific to each user.

Let us consider a specific industrial plant/ industrial park as depicted in Figure 3.

Figure 3: Flow diagram for wastewater reuse computation for Industries

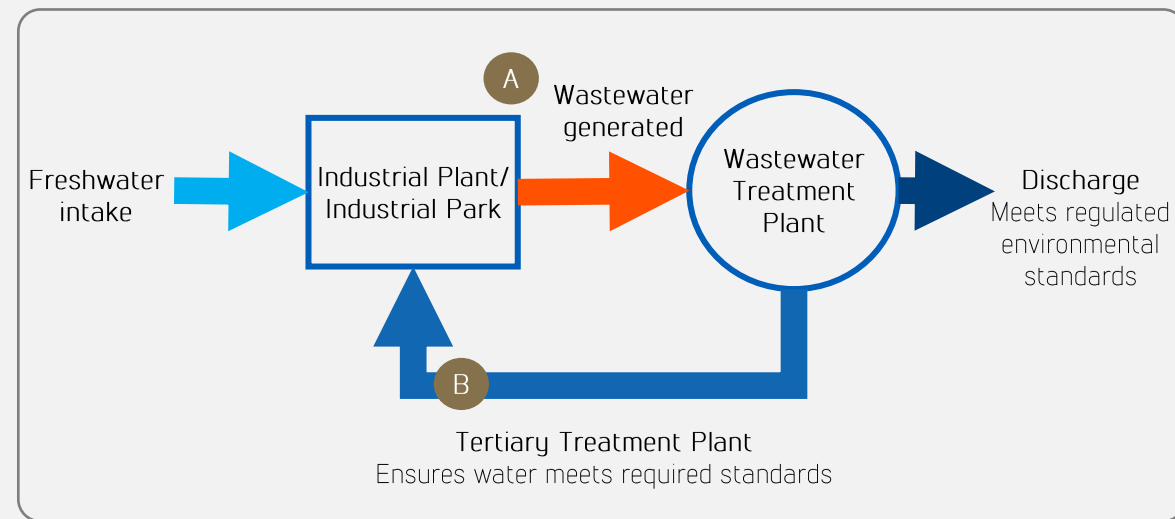

In this illustration, the percentage wastewater reused is provided by the following formula:

$$\text{Percent wastewater reuse (R)} = \frac{\text{Quantum of treated wastewater reused (B)}}{\text{Quantum of wastewater generated (A)}}$$

In case the user exceeds its wastewater reuse target (say T), then the industrial plant/ industrial park is issued WRCs equivalent to the difference between the percentage wastewater reuse and the reuse target, i.e. (R-T). Accordingly, users that are issued WRCs can sell them to others. The algorithm for issuance of WRCs is discussed in Section 3.7 and Annexure 9 of the Handbook.



Case 2: Urban local bodies

Here, WRCs will be issued to the entities that collect, treat and discharge domestic wastewater from cities and towns. Under initial phases, the focus will be on larger urban local bodies to maximize the benefit of water reuse in the cities. The recycled wastewater may be used by local industries, agricultural users, horticultural purposes, among other uses, and WRCs may be

traded amongst ULBs. This practice would encourage monitoring and compliance of wastewater from cities and towns for meeting environmental and health standards. Targets for this sector will be different from that of industrial users. Let us consider an urban local body as depicted in Figure 4.

In this illustration, the percentage wastewater reused is provided by the following formula:

$$\text{Percent wastewater reuse (R)} = \frac{\text{Quantum of treated wastewater reused (B)}}{\text{Quantum of wastewater generated (A)}}$$

Here too, the urban local body either sells or buys WRCs, depending on whether it has over-achieved or under-achieved, respectively, the reuse targets that it has been assigned.

Figure 4: Flow diagram for wastewater reuse computation for Urban Local Bodies

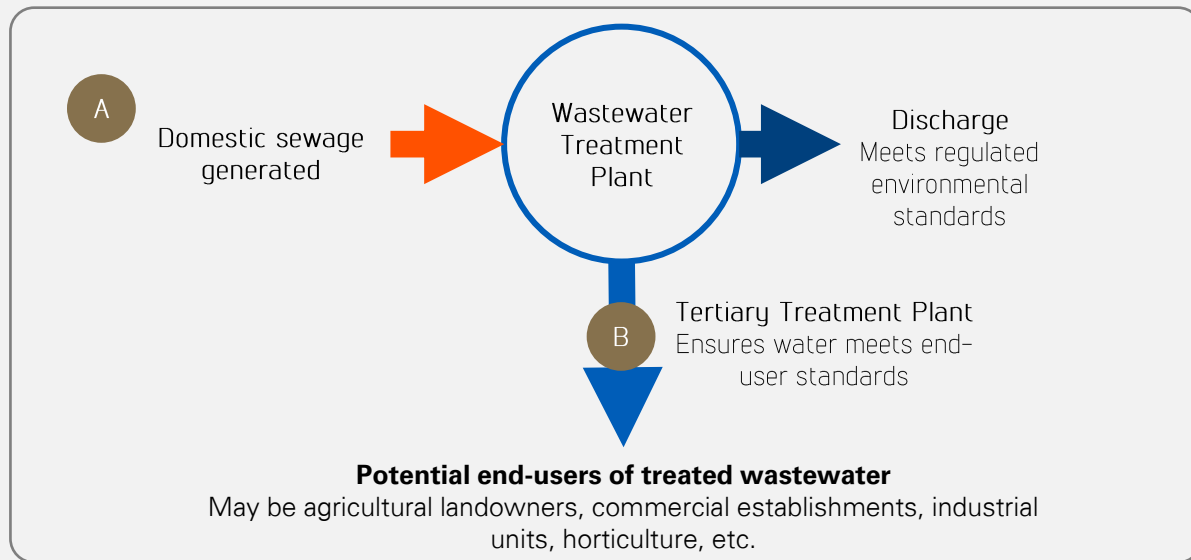

Case 3: Housing complexes and gated communities

This includes a separate yet sizeable sector of domestic sewage (like housing complexes and gated communities) that are otherwise not connected to the city-wide sewerage network maintained by urban local bodies. Here, housing complexes and gated communities collect, treat, dispose, and sometimes recycle wastewater. A key influencing factor for inclusion of housing

complexes and gated communities is the financial resources available and willingness of the community. Also, in this case, WRCs can be offset with property tax dues, resulting in monetisation outside the water sector. Let us consider a specific housing complex/ gated community as depicted in Figure 5.

Figure 5: Flow diagram for wastewater reuse computation for Housing Complexes/ Gated Communities

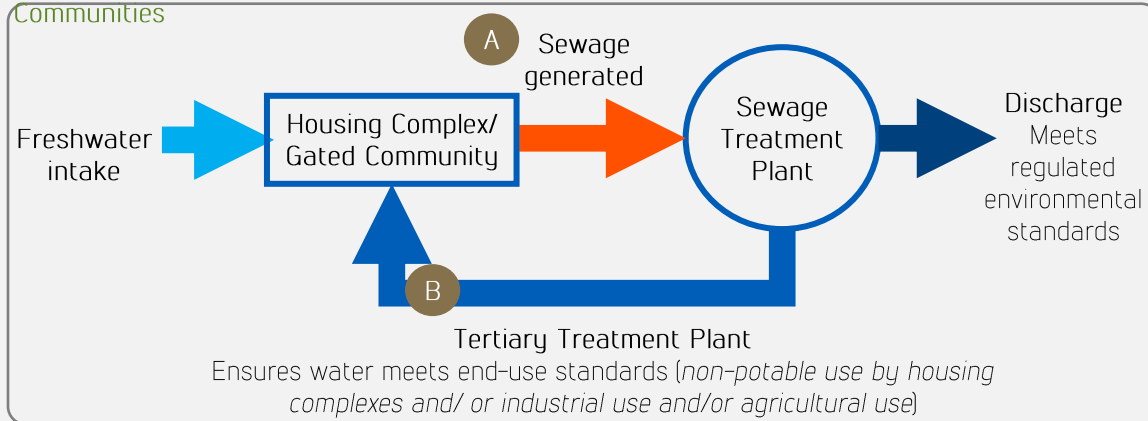

As with earlier cases, the percentage wastewater reused is provided by the following formula

$$\text{Percent wastewater reuse (R)} = \frac{\text{Quantum of treated wastewater reused (B)}}{\text{Quantum of wastewater generated (A)}}$$

Further, the housing complex/ gated community either sells or buys WRCs, depending on whether it has over-achieved or under-achieved the assigned reuse targets.

Case 4: Urban to agriculture flows of wastewater

This business case encompasses two sectors, namely urban and agriculture, where WRCs will be traded among urban users and agricultural landowners or workers, with the intent of facilitating reuse of treated wastewater from

urban areas to agriculture. Also, it would be critical to assess water quality that might otherwise pose risks if used for cultivation of food crops. Let us consider a specific agriculture sector user as depicted in Figure 6.

Figure 6: Flow diagram for wastewater reuse computation for Agricultural sector

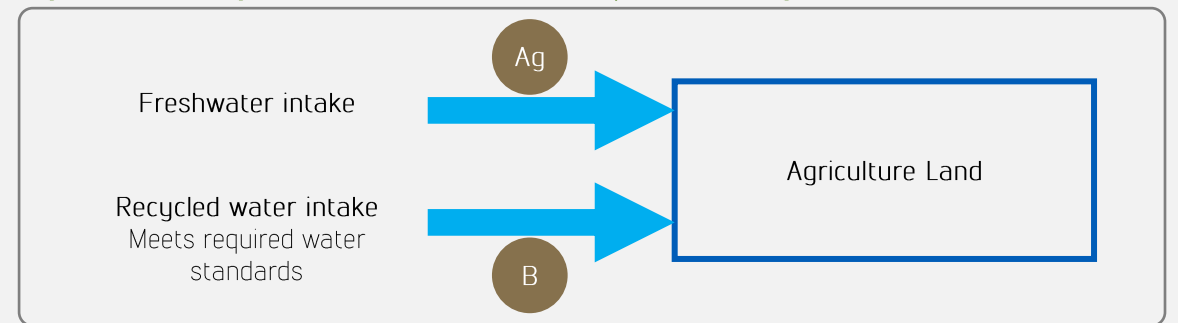

In this illustration, the percentage wastewater reused is provided by the following formula:

$$\text{Percent wastewater reuse (R)} = \frac{\text{Recycled water intake (B)}}{\text{Quantum of freshwater intake (Ag)}}$$

The agricultural landowner either sells or buys WRCs, depending whether it has over-achieved or under-achieved the assigned reuse targets¹²

12. As an alternate to including agricultural landowners in the WRC scheme, reuse of treated wastewater may be promoted in the agricultural sector by linking it with incentives provided by the government to the sector, i.e., providing incentives on exceeding reuse targets set.

Critical success Factors to WRC trading

Based on a study of similar cap-and-trade systems (as elaborated in Annexure 2.2), the critical success factors for the WRC scheme are illustrated in Figure 7. To ensure its success, these learnings have been incorporated in the design of the WRC scheme.

Figure 7: Critical success factors for WRC trading scheme

01	Fragmented governance structure, with overlap of regulator and executive functions	<ul style="list-style-type: none"> • Robust institutional structure, with separate entities for distinctive functions, • Entities with delineated and defined roles and responsibilities, • Information symmetry among stakeholders through guidelines, Standard Operating Procedures
02	Developing credible and acceptable baseline	<ul style="list-style-type: none"> • Transparent scientific mechanism for baseline determination, taking into consideration historical performances, and include stakeholder consultations
03	Fairness and appearance of fairness in target setting methodology	<ul style="list-style-type: none"> • Transparent target setting mechanism, with limited subjectivity, discretion or protectionism in favor of specific water users • Target setting based on economic potential for reuse among water users • Effective communication of incentives and penalty mechanism, with limited scope for discretion
04	Shortcomings in monitoring and verification mechanism	<ul style="list-style-type: none"> • Based on principles of data authentication, error detection and transparency • Adoption of IOT-sensor based real-time monitoring systems and use of digital technology for data capture and validation • Delineation of audit role, verification role, and issuance of WRCs
05	Price volatility during trading of credits, deterring long-term investments	<ul style="list-style-type: none"> • Ensure adequate of users to ensure sufficient market liquidity • Define floor and ceiling prices to ensure stability in price of WRCs

2. THE WRC ECOSYSTEM AND THE KEY ACTORS



The successful implementation of WRC concept requires an enabling institutional and policy framework. This framework should clearly delineate stakeholder roles and establish clear process flow for the various aspects of the WRC scheme, thus laying the foundation for a sound institutional mechanism and scheme design. The institutional mechanism needs to be elaborate, must address independence and accountability issues, and must inspire confidence among the stakeholders.

Institutional structure for the WRC scheme

The institutional structure for the WRC scheme – for both regulated and voluntary approaches – is discussed in Table 1.



Table 1 Institutional structure for WRC schemes

Regulated approach

- 1a. The Regulator identifies water users to participate in the scheme.
- 1b. The Registry (an agency designated and empowered by the Regulator) issues the Certification of Registration to the identified Designated Water User (DWU).
- 1c. The Regulator empanels Water Auditors to establish the user’s baseline in the baseline year and to support the monitoring and verification of user’s performance in the assessment year.
- 2a. The DWUs engages an empaneled auditor to establish its baseline.
- 2b. The Regulator sets targets for each DWU and notifies the targets.
3. The DWU undertakes appropriate measures to meet the respective reuse targets; its performance is assessed by an empaneled water auditor (different from the auditor engaged for baseline determination for independence purposes).
- 4a. The DWU applies for WRCs with the Regulator, by submitting the water audit report.
- 4b. The Regulator verifies the water audit report and accordingly issues WRCs to the DWUs.
- 4c. The details of issued WRCs are shared by the Regulator with the Registry.
5. The DWUs, depending on whether they have overachieved or underachieved their targets, place bids for selling or buying WRCs with the Trading Exchange.
6. The Registry confirms whether the DWUs submitting the sell bids have sufficient WRCs to sell.
7. The Trading Exchange process the trades and share the settlement details with the Registry.

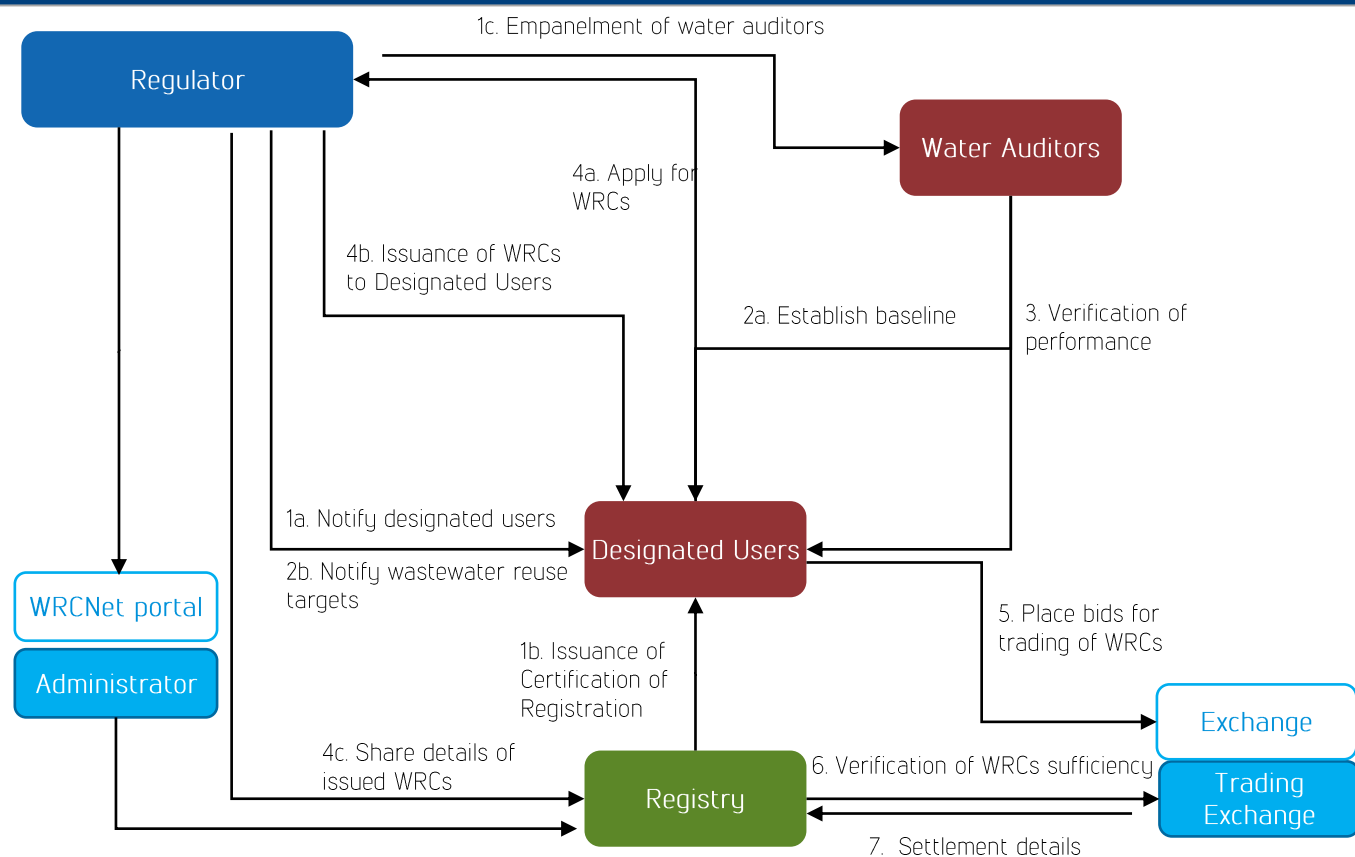

Voluntary approach

- 1a. The Anchor Entity (for instance, the regional industry association) processes voluntary applications from water users to participate in the WRC scheme.
- 1b. The Registry (an agency designated and empowered by the Anchor Entity) issues the Certification of Registration to the identified Designated Water User (DWU).
- 1c. The Anchor Entity empanels Water Auditors to establish the user's baseline in the baseline year and to support the monitoring and verification of user's performance in the assessment year.
- 2a. The DWU engages an empaneled auditor to establish its baseline.
- 2b. The Anchor Entity sets targets for each DWU.
- 3. The DWU applies for credit/ credit enhancement from the partner lending facility/ bank.
- 4. The DWU, with this credit support, undertakes appropriate measures to meet its targets; its performance is assessed by an empaneled water auditor (different from the auditor engaged for baseline determination for independence purposes).
- 5. The DWU applies for WRCs with the Certification Entity, by submitting the respective water audit report. The Certification Entity verifies the water audit report and accordingly issues WRCs to the DWUs.
- 6. The details of issued WRCs are shared by the Certification Entity with the Registry.
- 7a. The DWUs place bids for selling or buying WRCs with the Trading Exchange.
- 7b. The Registry confirms whether the DWUs that submit sell bids have sufficient WRCs to sell.
- 7c. The Trading Exchange process the trades and share the settlement details with the Registry.
- 8. The DWU, on meeting its reuse targets, seeks approval from the lending facility/ bank for graded interest rate subvention, which is provided to incentivize and create the market.

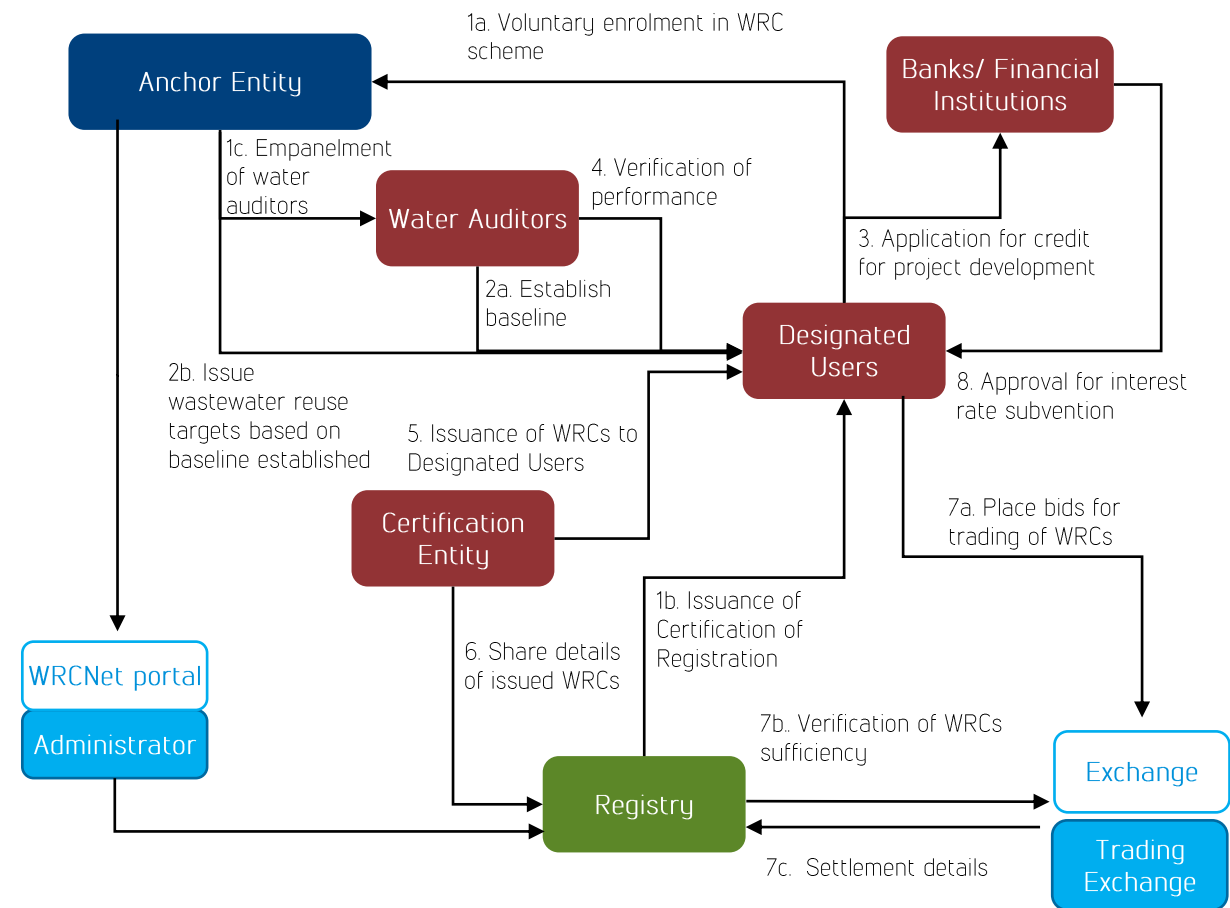



Under a regulated approach, the institutional mechanism shall vary slightly depending on whether the geography has a dedicated water regulator. For instance, Maharashtra (India) has a dedicated regulator – the Maharashtra Water Resources Regulatory Authority (MWRRA) – which is responsible for regulation, allocation, management, and utilisation of water resources in the state. However, Bangladesh has a robust Executive entity but does not have a dedicated water regulator. In such cases, the Implementation Agency of the WRC scheme shall create a separate department/ unit to facilitate the roll-out of the WRCs.

In Bangladesh, discussions are currently underway with the Government of Bangladesh and the 2030 WRG Bangladesh Water Multi-Stakeholder Partnership (MSP) on the institutional framework for the WRC scheme. To lay out the policy framework for the WRC scheme, tradable instruments for wastewater reuse are proposed to be defined both as part of Bangladesh's Industrial Water Use Policy and the Green Economic Zone Guidelines that are currently being conceptualized as part of the Industrial Water and Wastewater Workstream of the Bangladesh Water MSP. Also, the Government of Bangladesh, through legislative action, may entrust a public entity with the statutory responsibilities to promote wastewater reuse. Accordingly, the WRC scheme may be driven by the Department of Environment, the Water

Resources Planning Organisation (WARPO), the Bangladesh Economic Zones Authority (BEZA), or the Bangladesh Export Processing Zones Authority (BEPZA).

Ideally, the institutional mechanism of the WRC scheme shall involve separation of the regulator and executive functions, as much as possible. However, if the law of the land does not allow for such a separation, and if there is no operational regulator in the geography, then it is important to define an appropriate dispute-resolution mechanism for the WRC scheme. Here, any matter shall be brought in front of an independent body under the Executive-cum-Regulator, with acceptable covenants. The disputes shall be resolved mutually, with the Executive body having the final word. Further, the adoption of technological solutions shall ensure transparency and efficiency in the functioning of the system, hence making dispute resolutions transparent and redundant, as elaborated in Exhibit 1.

Exhibit 1: Role of technologies in enabling transparent implementation of WRCs

- **Continuous data curation using IoT techniques, anomaly detection using Machine Learning, Artificial Intelligence, and the use of tamper-proof distributed ledgers such as blockchains shall promote transparency and reduce the potential for fraud.**
- **To crowdsource ideas on tracking wastewater reuse through such technologies, the 2030 WRG and the MWRRA organized the 'Global Blockchain Hackathon for Clean Water' in January 2019. All resources of the event are available online at <https://wrc-hackathon.devpost.com>.**

The voluntary approach shall be moderated by globally relevant and country-specific industry associations. The 2030 WRG has undertaken preliminary discussions with regional and country-specific industry associations such as the Asia-Pacific Economic Cooperation (Singapore), Federation of Indian Chambers of Commerce and Industries (FICCI), Confederation of Indian Industries (CII), and Associated Chamber of Commerce and Industries (ASSOCHAM), among others. Further, the voluntary approach shall involve independent certification organizations with expertise in certifications, have capabilities to create water use baselines and monitor wastewater recycle/ reuse, understand the metering and data communication protocols and act with highest professional standards, given the

links to the financing facility. Accordingly, the voluntary approach may involve reputed organizations with the necessary capabilities. Such organizations, like the Green Buildings Certification Institute, American Water Works Association, and their country-specific chapters, can act as franchisees, should there be an interest from their side to facilitate the WRCs trading,



Roles & Responsibilities of key actors

The key actors across the regulator-driven scheme and voluntary scheme are described in Table 2

Table 2 Key actors under WRC scheme

S.No.	Actor	Description
1	Regulator	Designated public entity responsible for the implementation of WRC scheme. <ul style="list-style-type: none"> Identifies and notifies the water guzzling users to participate in the WRC trading cycle. Notifies rules, regulations, and guidelines to launch and implement the WRC scheme – including for water auditing/ baseline study, appointment of independent water auditors, issuance of WRCs, installation of online water meters and data capture, etc.
2	Anchor Entity	Region-specific industry associations or independent not-for-profit entity that launches the voluntary WRCs scheme in the specific geography, subscribing to setting up a robust process of issuance of WRCs and managing the interactions with all relevant stakeholders – including signing MOUs/ letters of cooperation with participating banks and financial institutions in the interest buy-down process. <ul style="list-style-type: none"> Notifies rules, regulations, and guidelines to launch and implement the WRC scheme.
3	Administrator	Entity designated by the Implementation Agency to create and maintain a secure online platform (defined as the WRCNet Portal) to accept site-wise data on water use, wastewater generation, recycle/ reuse, and kept under stringent data protection procedures and industry-accepted encryption/decryption protocols.
4	Registry	Entity designated and empowered by the Implementation Agency to drive registration of users in the WRC scheme and maintaining the database of users and issued WRCs.
5	Certification Entity	Independent entity accredited by suitable regulatory national or international bodies and chosen by the Implementation Agency to verify the auditor's report as to whether the wastewater reuse targets have been achieved. <ul style="list-style-type: none"> Certifies equivalent WRCs as per the performance of the users vis-à-vis the set targets.
6	Trading Exchange	Entity that is designated by the Implementation Agency and is responsible for running the designated trading platform/ Exchange for trading of WRCs among users. <ul style="list-style-type: none"> Possesses experience of operating trading exchanges and ensures trading with the strict standards of transparency.
7	Water Auditor	Entity empanelled by the Implementation Agency to establish the user's baseline in the baseline year and evaluate the user's performance in the assessment year.

S.No.	Actor	Description
8	Banks/ Financial Institutions	<ul style="list-style-type: none"> • A financing entity that subscribes to develop an interest buy-down facility, collaborating with any development finance institution or raises capital through legitimate local regulator-approved means of reaching out to the capital markets. • While such entities are envisaged under the voluntary approach to incentivize the users making investments to achieve their targets, such entities may be identified by the Regulator in a regulated approach as well.
9	Designated Water User	Large water-guzzling entities that are notified by the Regulator or that are approached by the Anchor Entity or the program managers to take part in the WRC scheme and WRCs issuance process.

The activities involved in the WRC scheme and the actors responsible for them, in a regulated approach and a voluntary approach, are discussed in detail in Annexure 3.

The Implementation Agency shall identify appropriate public or private or independent entities for undertaking specific roles, as per their strengths and capabilities. The same entity may play multiple roles; however, to ensure high levels of market integrity, there shall not exist any actual or even perceived conflict of interest in the assigned responsibilities. Also, in case private entities are identified, sufficient care shall be taken to ensure data confidentiality and market integrity. Further, as required, capacity-needs assessment of the identified entities shall be conducted, and requisite training and capacity building shall be provided.



3.1 Designation of users to participate in trading scheme	3.2 Establish the baseline	3.3 Notification of reuse targets	3.4 Install hardware for real-time monitoring and data capture	3.5 Data transmission and storage	3.6 Data validation through algorithms	3.7 Issuance of WRCs	3.8 Notification of the trading process	3.9 Set Pricing Guidelines	3.10 WRCs reporting and settlements	3.11 Renotification of users
---	----------------------------	-----------------------------------	--	-----------------------------------	--	----------------------	---	----------------------------	-------------------------------------	------------------------------

3. IMPLEMENTATION OF WRC IN A GEOGRAPHY



The implementation of the WRC scheme involves numerous steps, as depicted in the process flow in Figure 8. Each step in the process flow is elaborated in subsequent sub-sections of the Handbook.

Figure 8: Process flow for implementation of WRC

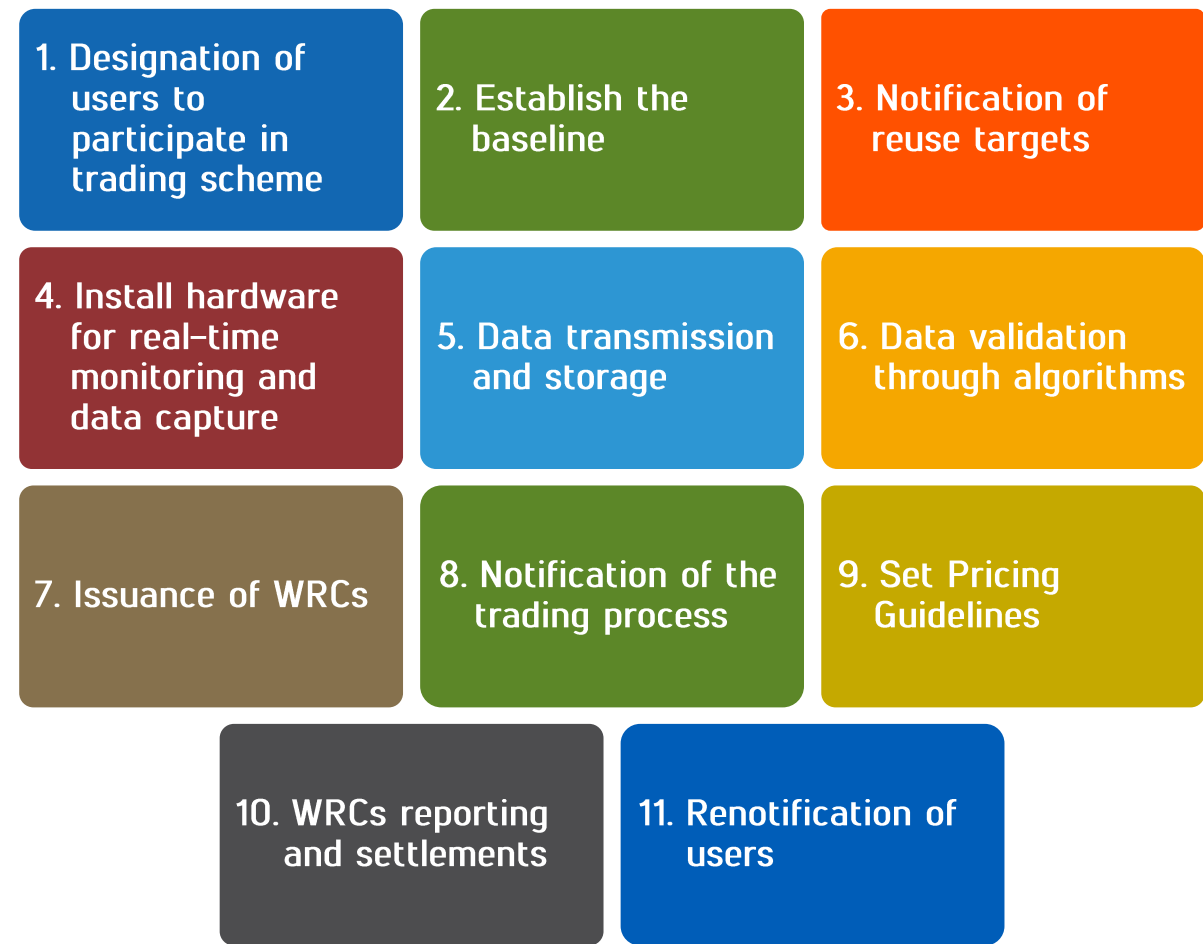

3.1 Designation of users to participate in trading scheme

Shortlisting of top users

The WRC trading scheme shall be implemented in a phase-wise manner to allow for staggered scheme expansion and improvement. The number of sectors and users in subsequent phases shall increase progressively, allowing for buy-in from new users through successes and adopting learnings from earlier phases. This shall also allow for sectors and users to invest in technological innovations and attain maturity on water-use

efficiency and wastewater reuse technologies.

Phase 1 of the WRC scheme may include top urban local bodies, large commercial establishments, top individual industrial units, or a group of industries. For instance, for the WRC scheme in Bangladesh, the roll-out plan under discussion is depicted in Figure 9.

Figure 9: Phase-wise roll-out of regulator-driven scheme under discussion in Bangladesh

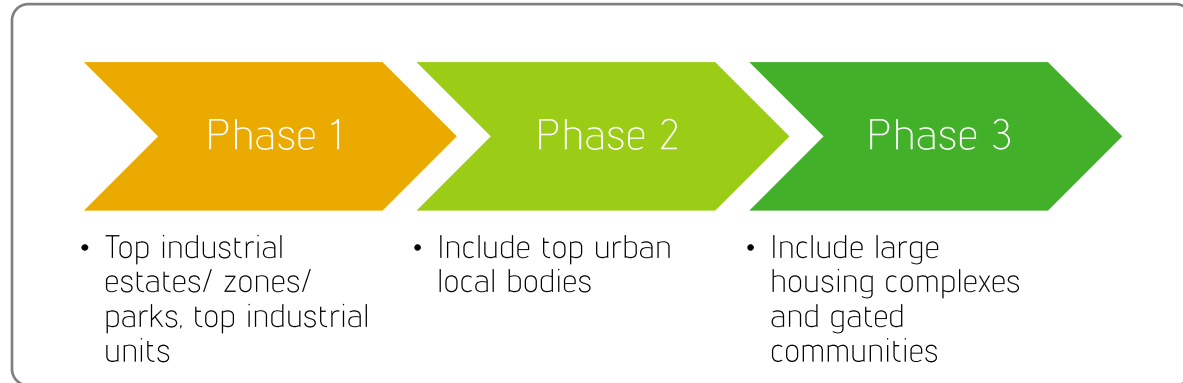

Further, the water consumption of the identified users is estimated on a Gate-to-Gate basis, as depicted for an industrial user in Figure 10, where total water withdrawal is the cumulative

withdrawal across all activities carried out within the boundary of the water user.

Figure 10: Gate-to-Gate concept for water withdrawal

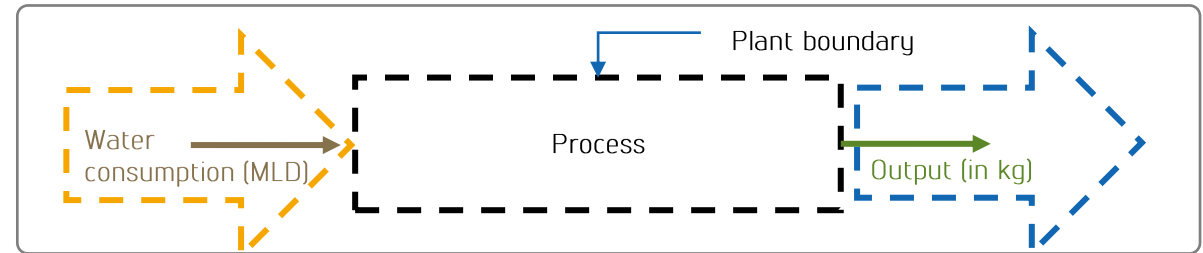

Each phase of the WRC scheme shall include adequate water users to ensure sufficient liquidity in the market during trading. While the details on

trading between users is elaborated in Sections 3.8 – 3.10, the significance of ensuring liquidity is elaborated in Exhibit 2.

Exhibit 2: Significance of adequate liquidity in the market

Under the WRC scheme, users, depending on whether they have overachieved or underachieved their targets, will sell or buy WRCs respectively. If the market has limited WRCs to trade, then it will lead to illiquidity, under the following scenarios:

- **There is limited demand for WRCs – This situation can arise when most users have overachieved the targets and the number of available issued WRCs is much more than the demand.**
- **There is limited supply of WRCs – This situation can arise when most users have underachieved the targets and the number of available issued WRCs is much less than the demand.**

For the success of the scheme, it is critical to ensure that there is adequate liquidity in the market for WRCs both from a demand and supply perspective. To achieve this objective, the baseline determination and target-setting approach should take into account adequate representation from both leading and lagging performers in a particular sector.

Shortlisting of top industrial users

To identify top industrial users, the Implementation Agency shall first identify the target industrial sectors. These shall be water-intensive sectors, with high water withdrawals. Other factors to consider include the availability of wastewater reuse technologies, investment needed for water-use efficiency and wastewater reuse interventions, and the capacity of the individual users within the sector to invest in reuse technologies.

The initial shortlisting of industrial users involves the following steps:

- Assess the annual water withdrawal over the past three years of each industrial unit or a group of industrial units.
- Estimate the total water withdrawal for each industrial sector (by adding annual withdrawal of relevant industrial units) and define a threshold of the number of industrial sectors to be included under the specific phase of trading, say industrial sectors consuming 50% of the total industrial water withdrawal.
- Assess the total annual production of the past three years for each industrial unit

- Compute the specific water withdrawal for each of the past three years for each user.

$$\text{Specific Water Consumption (SWC) of user in } n\text{th year} = \frac{\text{Annual water consumption of } n\text{th year}}{\text{Annual production of } n\text{th year}}$$

$$\text{Average SWC of } i^{\text{th}} \text{ user} = \frac{(SWC)_{i,T-2} + (SWC)_{i,T-1} + (SWC)_{i,T}}{3}$$

where $(SWC)_{i,T}$ is the annual specific water consumption of the User i in year T

- Within each of the selected industrial sectors, list out the individual industrial units in descending order of their average specific water withdrawal. Define a threshold of the number of industrial units to be included under the trading scheme, say the top 50% of industrial users by specific water withdrawal.

These thresholds may vary across geographies, depending on the mix of water users, the industrial profile, and maturity of the regulatory system.

Figure 11: Illustrative selection of top industries within an Industrial sector

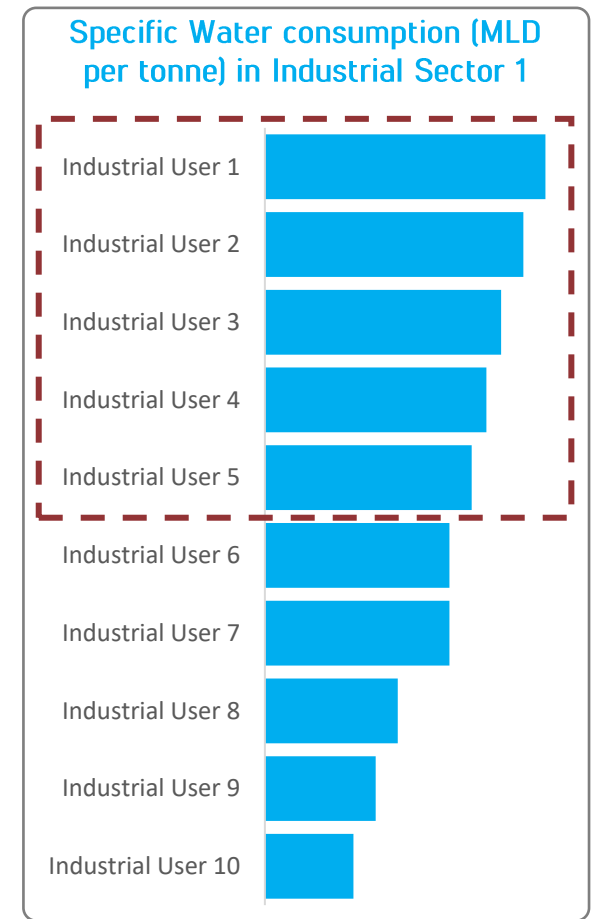

Shortlisting of top urban local bodies

The shortlisting of domestic bulk users involves the following steps:

- Assess the annual water consumption of each urban local body over the past three years
- Compute the average water consumption over the past three years for each user

Average Water Consumption of i^{th} user=

$$[(\text{Water Consumption})_{i, T-2} + (\text{Water Consumption})_{i, T-1} + (\text{Water Consumption})_{i, T}] / 3$$

where (Water Consumption) i, T is the annual water consumption (in million litres) of the User i in year T .

- List the urban local bodies in descending order of their average water withdrawal.
- Define a threshold of the number of users to be included under the trading scheme. For instance, as depicted in Figure 12, the Implementation Agency could select the top 50% of urban local bodies by water withdrawal

Figure 12: Illustrative selection of top urban local bodies

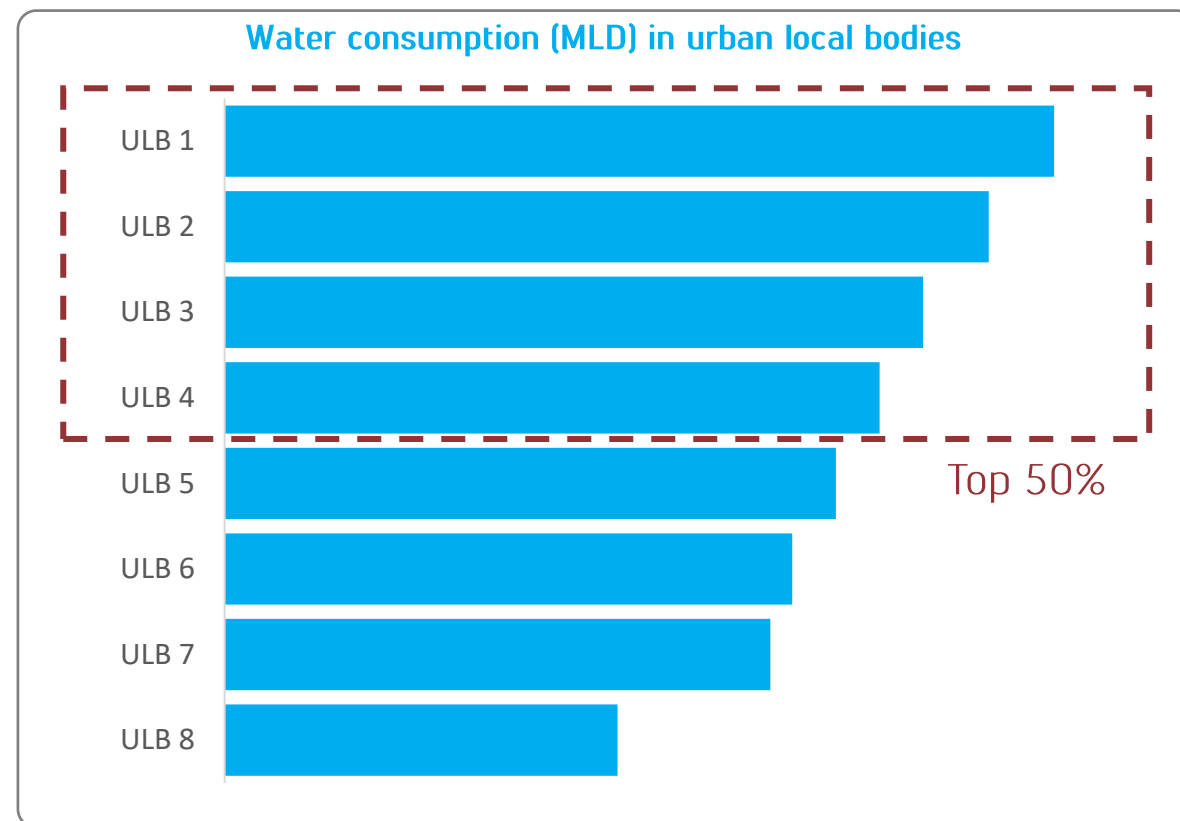

On shortlisting users to participate in the trading scheme, the Implementation Agency shall engage with the users and notify them on their expected participation. It shall conduct extensive consultations with the notified users aimed at discussing the objectives of the trading scheme, the benefits to the users, the process flow, and the expectation from the users.

Development of WRCNet Portal

The WRCNet Portal is the web interface that shall be developed to support the WRC trading scheme. This portal shall be used for several key activities, including registration of users, recording the baseline, notification of reuse targets, monitoring and validation of user performance, and verification of WRCs for

trading. The WRCNet Portal shall be built upon the principles of layered architecture. The proposed solution architecture of the WRCNet Portal is provided in Figure 13.

Figure 13: Solution architecture of the WRCNet Portal

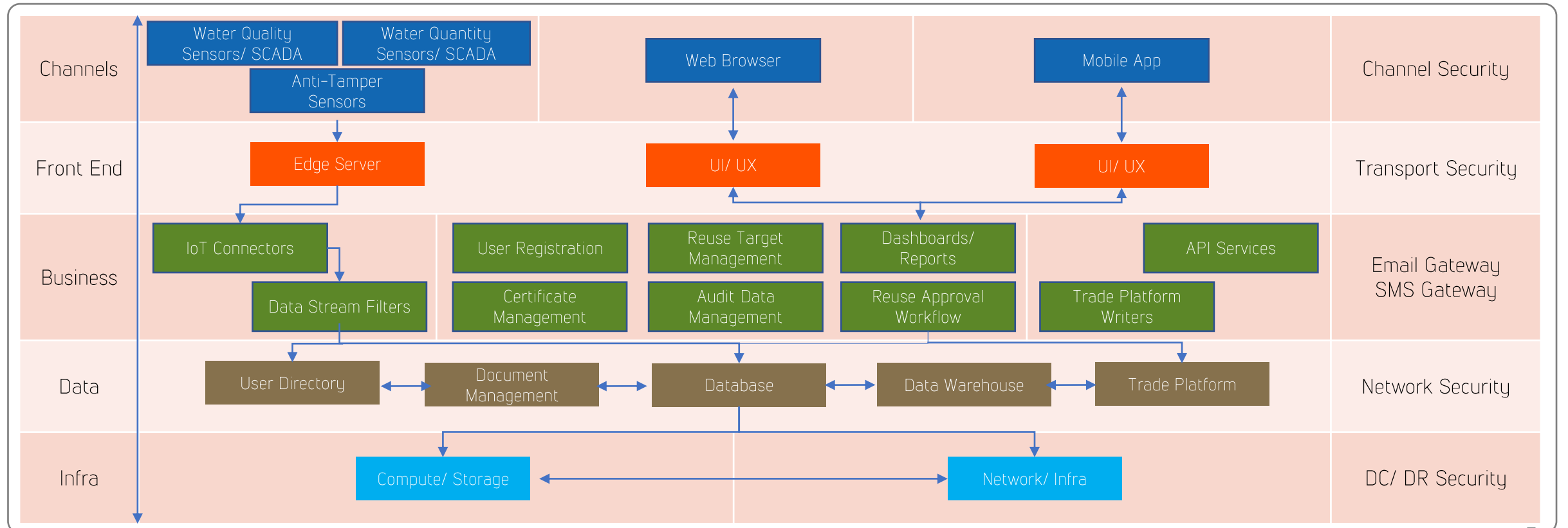



3.1 Designation of users to participate in trading scheme

3.2 Establish the baseline

3.3 Notification of reuse targets

3.4 Install hardware for real-time monitoring and data capture

3.5 Data transmission and storage

3.6 Data validation through algorithms

3.7 Issuance of WRCs

3.8 Notification of the trading process

3.9 Set Pricing Guidelines

3.10 WRCs reporting and settlements

3.11 Renotification of users

The topmost layer shall be the layer of the Channels interacting with the proposed architecture, comprising of IoT sensors or SCADA/ DCS (communicable metering devices), predominantly comprising the water quality and quantity sensors, and the responsive web browsers and mobile apps.

The Front-End layer may comprise of the Edge Server located at the consumption endpoints in the cases with no SCADA/ DSC available, and this will be responsible for aggregating or filtering sensor data before transmitting it to the WRCNet Portal and the web-based or mobile-based User Interfaces. In cases where the security protocols for data transfer from IOT meters to the main database is robust and compliant with the system architecture, the need for an edge-server will be negated.

The Business layer shall have several business components and will materialize the use cases of the WRCNet Portal, mainly:

- a. IoT Connectors – responsible for receiving data transmitted by the IoT sensors or SCADA/ DCS mounted at the water consumption points and Wastewater Treatment Plant, along with protocol integrations and format translations.

- b. Data Stream Filters – responsible for filtering, verifying, and validating the required data as per the exception or threshold criteria (if any).
- c. User Registration – responsible for managing (creating, reading, updating, and deleting) the registrations of various users of the portal.
- d. Reuse Target Management – responsible for managing (creating, reading, updating, and deleting) baselines and targets of reuse of water for various water users.
- e. Certificate Management – responsible for managing (creating, reading, updating, and sharing) certificates for various water users.
- f. Audit Data Management – responsible for generating audit schedules for water auditors and capturing and sharing audit related data and reports.
- g. Reuse Approval Workflow – responsible for instantiating reuse-related approve/ reject workflows for the issuance of WRCs
- h. Trade Platform Writers – responsible for writing relevant data post validation and verification into the WRC Trade Platform.
- i. API Services – responsible for integration with external systems, if any, particularly

payment gateways, SMS gateways, e-mail gateways etc.

- j. Dashboards & Reports – responsible for presenting various stakeholder dashboards and generating descriptive, predictive, and prescriptive analytical reports.

The Data layer shall save the various records into the database, save documents and content in the document and content management systems, aggregate data into the Data Warehouses for Business Intelligence, and sliced and diced MIS/ Dashboard reports; user credentials into User Directory, and the trade transactions into either Blockchain or a similar data-protected platform.

The final layer – the Infrastructure layer – shall comprise of the highly available, fault tolerant, recoverable computes, storage, and network components for the smooth execution of the WRCNet Portal solution in cloud or on-premise Data Centre with Business Continuity planned in the Disaster Recovery site with requisite Recovery Time Objective and Recovery Point Objective.

The entire solution needs to be covered with a Security envelope at various layers to prevent cyber threat vectors of any kind from attacking the proposed system, the proposed system.



Registration of users on the WRCNet Portal

On identification of the top water users, the WRCNet Portal shall allow for their registration by filling in the registration application. Apart from the Designated Water User, the Implementation Agency, Registry, Certification Entity, and Auditor will also have login credentials to the WRCNet portal. The guiding flow for registration of users on the WRCNet Portal is presented in Figure 14.

Figure 14: Process flow for registration of users on the WRCNet Portal

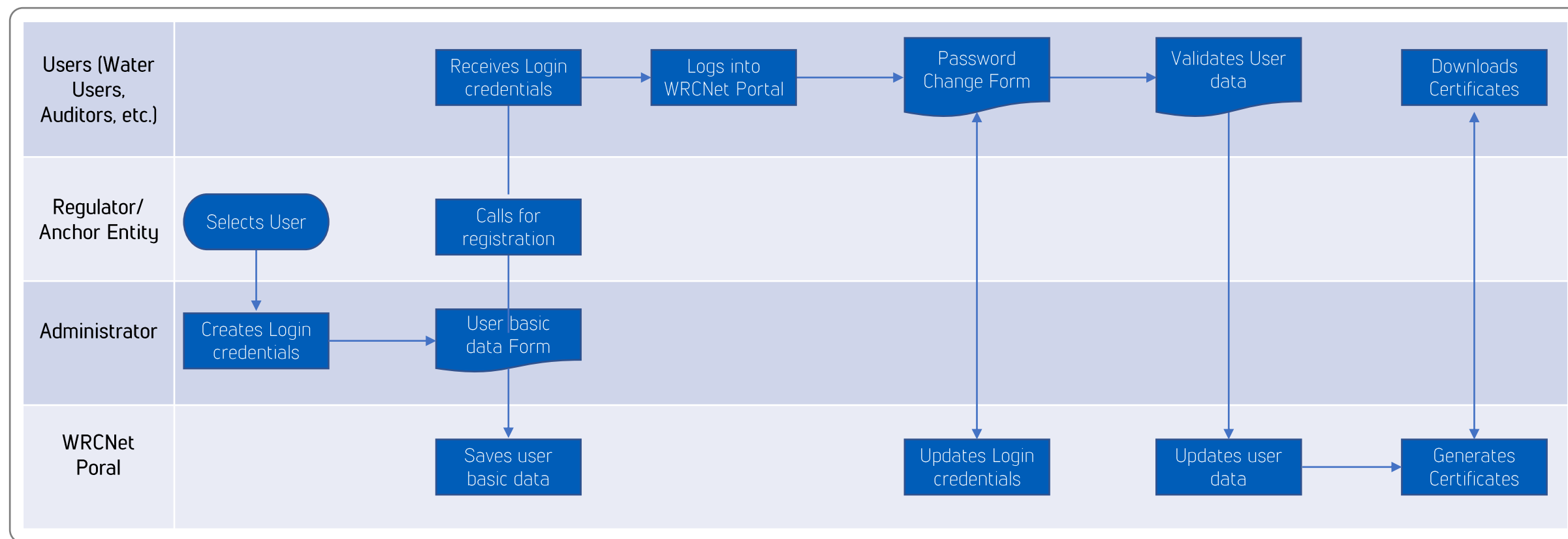

Under the proposed flow, the Implementation Agency informs the WRCNet Portal Administrator, who in turn creates the user with basic attributes using the "User Basic Data Entry Form" and saves this in the WRCNet Portal database. Then, the Designated Water User registers using the provided user registration link. On receiving the link for registration, the user validates the respective data and provides additional information and details. The details and documents submitted by the Designated Water User shall be verified and clarifications sought in case of any discrepancy. On verification of the completeness of the application, the 'Certificate of Registration' is issued to the Designated Water User; the user may download the bona fide certificate from the WRCNet Portal.

The indicative schematic diagram in Figure 15 shall guide the data model for the user registration business module of the WRCNet Portal. The sector and sub-sector of the water user is recorded in the Registration Module. A Role is a set of permissions, including read, write, update and view capabilities; each user belongs to a group of users having similar roles. Also, each user will have a unique password and Certificate of Registration.

Figure 15: User Registration business module of the WRCNet Portal

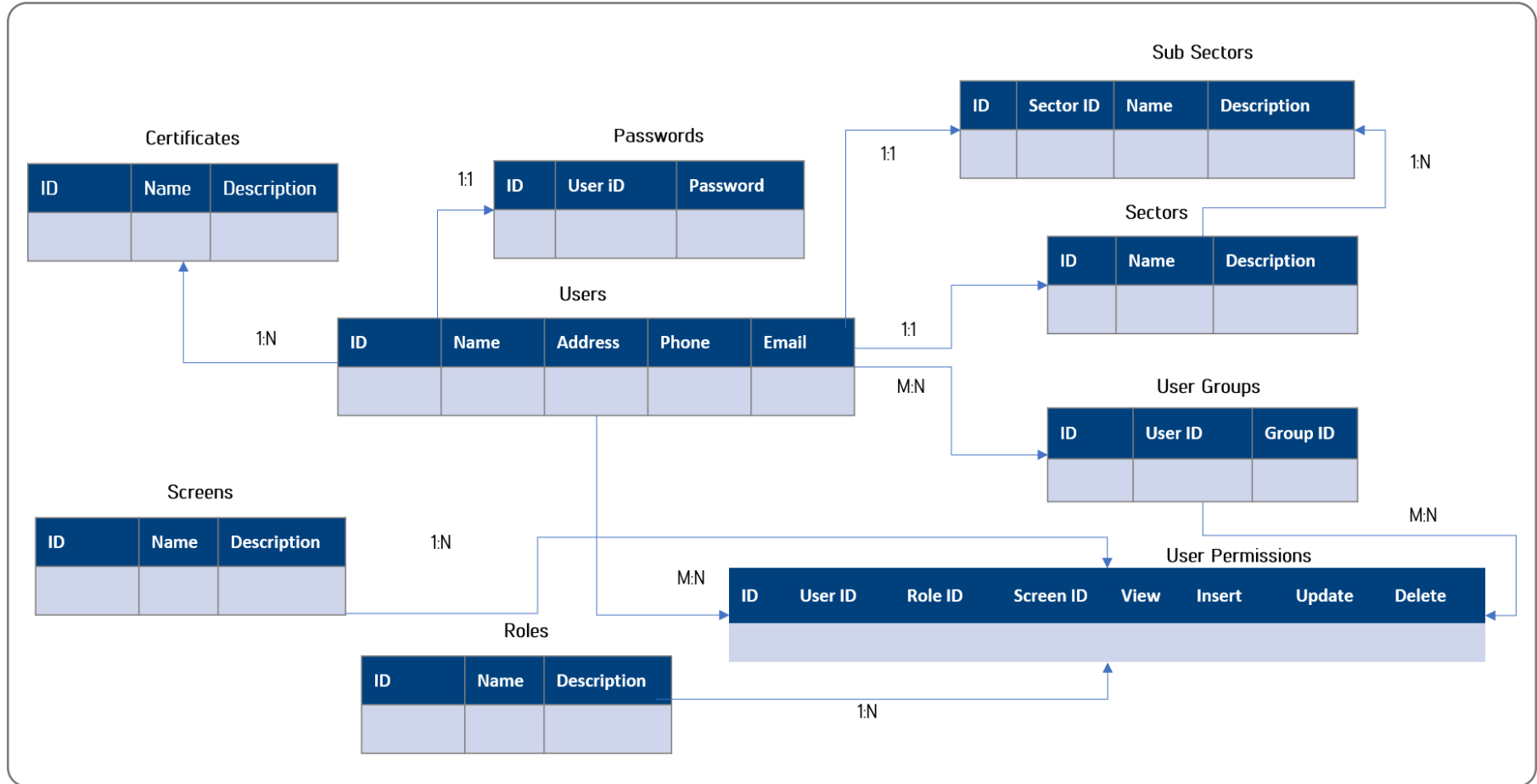

The solution components provided in Figure 16 shall indicatively materialize the use cases of the user registration module. Using the channels of web browsers or mobile app, the user who has received the registration link shall be able to invoke the page of the user registration business module to update the password. The new password entered by the user shall get saved in the user directory, meant for credential storage and access management. The second factor for user authentication shall be either Google Recaptcha or an OTP verification using SMS/e-mail gateways.

Figure 16: Use cases of the User Registration business module

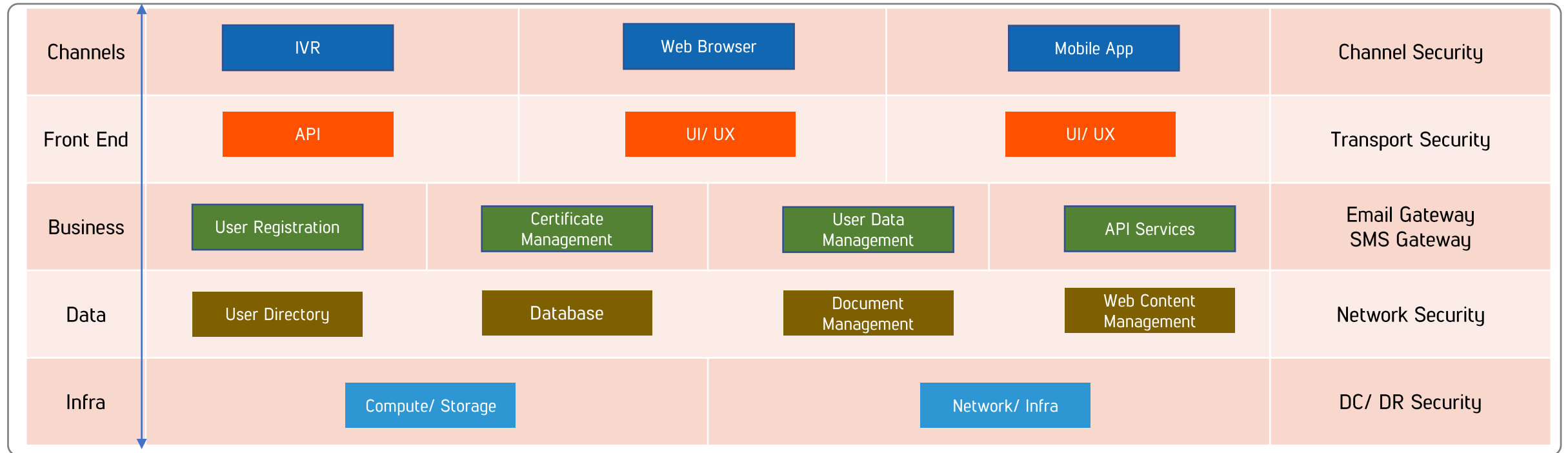

The user shall be able to view the respective user data from the user data management module of the WRCNet Portal, and update and save this in the Portal database. The certificate for the water user gets generated by the Portal, saved in the Documents Management repository of the Portal, and shared with Digital Key signature.

The Front-End layer comprising of the UI/ UX of the WRCNet Portal for each of the steps involved in the registration process, with indicative screens and operations, are provided in Annexure 4.

The final list of Designated Water Users will be shared with the Administrator and the Trading Exchange.

3.2 Establish the baseline

Methodology to establish the baseline

Based on a review of similar cap-and-trade and environmental trading schemes (as discussed in Annexure 5.1), the methodology to establish a baseline shall be based on the following principles:

- **Comprehensible:** Must be easy and inexpensive to carry out for the water users.
- **Conservatism:** Must reflect the most likely scenario in the absence of WRC-related interventions.
- **Accuracy:** Must enable users to make business decisions with reasonable assurance about the integrity of the information and must identify uncertainties and highlight elements that are expected to minimize uncertainties.
- **Transparency:** Must be replicable by an independent third-party, which is based on the defined methodology.
- **Consistency:** Must allow for meaningful comparisons of recycled wastewater over time.
- **Stability:** Must be stable over the short-term and not exhibit variations.

Establishing the baseline for WRC scheme

Under the WRC scheme, the baseline is defined as the quantity of wastewater reuse that is most likely to take place in the absence of the proposed interventions. So, establishing the baseline involves assessing actual or historical performance, say over the past three or five years, as per the discretion of the Implementation Agency. The exercise shall involve collecting data on several parameters, depending on the type of users.



Case I: Industrial Unit (Large industries, industrial parks, SEZs)

The data to be collected for industrial Designated Water Users are provided in Table 3.

Table 3: Establishing baseline from industrial Designated Water Users

S. No.	Parameter	Data Points
1	Water supply services	<ul style="list-style-type: none"> • Source of water • Bulk water rates • Tariff for industrial users • Institution responsible for tariff setting & collection
2	Industrial output of each industrial unit	<ul style="list-style-type: none"> • Product type • Types of unit processes • Installed production capacity • Actual annual output
3	Water consumption	<ul style="list-style-type: none"> • Total water consumption for each unit process • Quantity and tariff from different sources - water withdrawal from environment, reclaimed water • Water quality requirements for each unit process in production
4	Industrial effluent	<ul style="list-style-type: none"> • Total effluent generated • Total effluent treated • Total treated effluent reused

S. No.	Parameter	Data Points
5	Effluent treatment infrastructure	<ul style="list-style-type: none"> • Installed capacity • Current capacity utilization • Technology • Average quality of Treated Wastewater (TWW) • Amount of TWW reused
6	Current or planned interventions for water-use efficiency	<ul style="list-style-type: none"> • Promotion of water conservation • Promotion of demand side water efficiency • Promotion of wastewater reuse

Case II: Urban Local Bodies

The data to be collected for domestic Designated Water Users are provided in Table 4.

Table 4: Establishing baseline for Urban Local Bodies

S. No.	Parameter	Data Points
1	Water supply services	<ul style="list-style-type: none"> • Source of water • Institution responsible for tariff setting & collection
2	Water consumption	<ul style="list-style-type: none"> • Total water consumption • Quantity and tariff from different sources – water withdrawal from environment, reclaimed water • Water quality requirements
3	Domestic wastewater/ sewage	<ul style="list-style-type: none"> • Total wastewater generated • Total wastewater treated • Total treated wastewater reused
4	Sewage treatment infrastructure	<ul style="list-style-type: none"> • Installed capacity • Current capacity utilization • Technology • Average quality of TWW • Amount of TWW reused
5	Current or planned interventions for water-use efficiency	<ul style="list-style-type: none"> • Promotion of water conservation • Promotion of demand side water efficiency • Promotion of wastewater reuse

Normalization of baseline

The baseline for each Designated Water User shall be rationalized, considering factors that impact production and water consumption under equivalent conditions. Such factors may include capacity utilization (due to availability of fuel/ raw material, force majeure conditions), product mix and intermediary product, fuel quality, raw material quality, addition of new line/ unit, change in process technology, external factors, etc. Accordingly, while establishing the baseline, the values are to be normalized to address anomalies, if any.

For instance, consider an industrial unit. The unit may witness a low capacity utilization over one of its years, and accordingly a reduced water consumption, due to a force majeure situation. In a scenario where other factors remain constant, the normalization methodology is as follows:

- i. Define a minimum and maximum annual capacity utilization threshold based on historical industry patterns. For instance, let us consider that no normalization will be undertaken if annual capacity utilization is between 70% and 90%. Normalization is undertaken for capacity utilization below the lower limit and above the upper limit.
- ii. Collect operating data of the plants for plant load of 90%, 80% and 70%. Accordingly,

calculate average normalization factor (m^3 per MT of output) per percentage reduction in plant load.

- iii. The impact of capacity utilization is computed by the following:
 - a. If Capacity utilization > Upper limit, then impact = (Actual capacity utilization – Upper limit) * Average normalization factor per percentage reduction
 - b. If Capacity utilization < Lower limit, then impact = (Lower limit – Actual capacity utilization) * Average normalization factor per percentage reduction

Accordingly, normalization factor will be estimated for each type of water user and will be factored in while establishing the baseline. An illustrative example of establishing the baseline, with normalization factor considered, is provided in Annexure 5.2.

Empanelment of water auditors

The WRC scheme will involve independent water auditors, who will establish the baseline based on the rules and procedures developed by the Implementation Agency. To ensure independence of the water audit process, the Implementation Agency will empanel technically competent water auditors.

Also, the implementation of the WRC scheme shall encourage the launch of a regional certification system for water auditors' by defining the qualification criteria, the evaluation process, and the certification mechanism.

The qualification criteria for empaneling water auditors could be geography/ industry/ sector

specific, considering the landscape of water auditing practice in the concerned geography/industry/sector whichever is/are applicable. The objective will be to ensure the maximum representation of firms considering all these factors. Some illustrative criteria for empanelment of water auditors are provided in Exhibit 3.

Exhibit 3: Illustrative criteria for empanelment of water auditors

- **Minimum 10 years of experience of auditing users in the specific sector, having completed minimum 5 audits of 10,000 m³/ day each or a cumulative audit of over 100,000 m³/day.**
- **Relevant experience in water use efficiency, Non-Revenue Water (NRW) assessment, Water Resources Development and Management; with supporting documents in the form of completion certificates.**
- **Experience of conducting water audits to be supported by documents like water audit reports and completion certificates.**
- **Experience in estimation of capex and opex (threshold to be defined as per industries) of wastewater treatment infrastructure.**
- **Ownership of basic equipment, including Acoustic Doppler Velocimeter, Anemometer, Current Meter, Flow Meter/ Probe, Electromagnetic Sensor, Ultrasonic Flow Measurement, Laser Based Flow Meter, Manometer/ Pitot tube.**

Each empaneled water auditor shall be registered on the WRCNet Portal. The list of empaneled water auditors shall be provided on the WRCNet Portal for the Designated Water Users to engage their services.

Activities undertaken by the water auditor

The Implementation Agency shall develop guidelines to be followed by the water auditor. A summary of these activities is provided in Figure 17. The water auditor will present its findings and recommendations in the form of a water audit report, as discussed in Annexure 6.

Figure 17: Summary of steps involved in a water audit

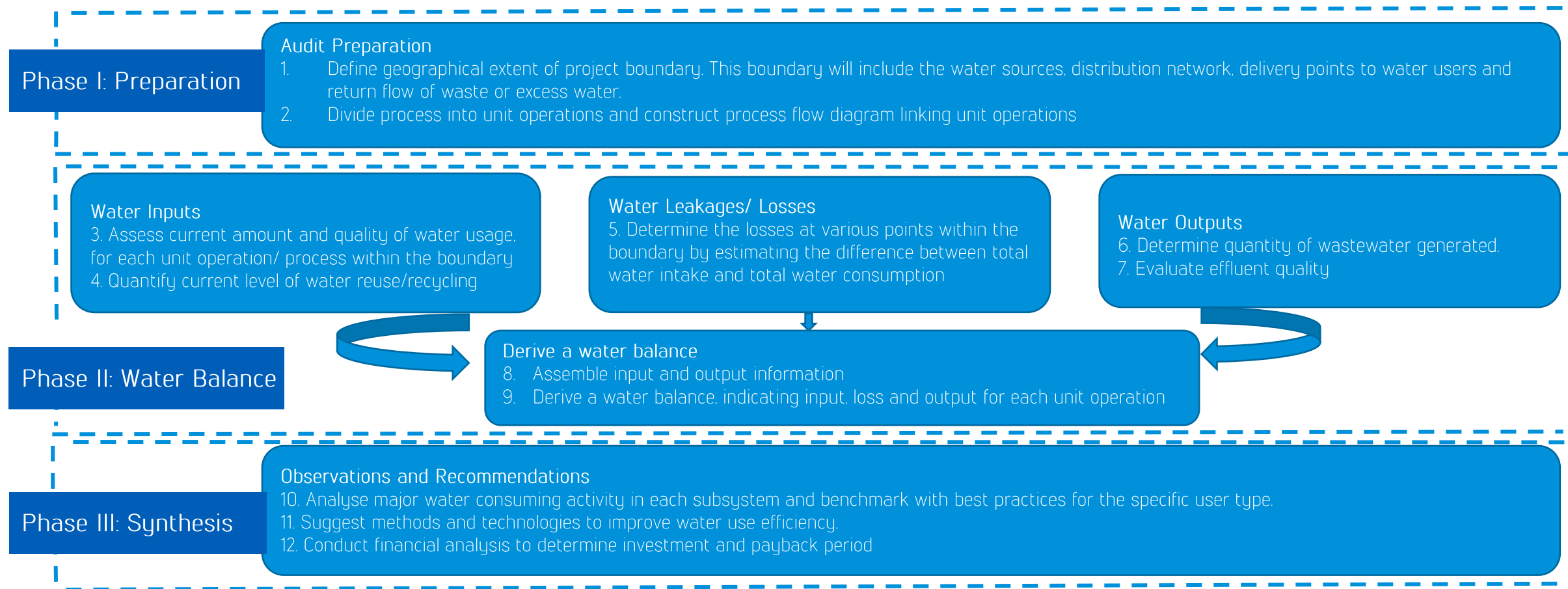

3.3 Notification of reuse targets

On establishing the baseline for the Designated Water Users, the Implementation Agency will set reuse targets. The target setting methodology will involve understanding the current state of technological innovation and assessing the technical potential for maximum water efficiency and wastewater reuse.

Overview of technological interventions

Treated wastewater has a variety of applications – agricultural, environmental, industrial, recreational, potable, and others; these have been discussed in

detail in Annexure 7.1. The specific end-use of reclaimed water depends on the quality achieved: the quality standards are broadly classified into three types – Grade A, Grade B and Grade C, with Grade A being the most stringent and Grade C the least stringent. For instance, for potable use, Grade A reclaimed water is recommended. Accordingly, the appropriate grade of reclaimed water for different categories of end-use is discussed in Annexure 7.2. Further, for different categories of end-use and target quality parameters, different technological processes are recommended and are discussed in Annexure 7.3.

Cost for wastewater treatment depends on the adopted technology, which in turn depends on the influent raw wastewater quality and the target effluent limit. The costs have two parts: one-time capital cost and recurring annual O&M cost.

Illustration: Costs in India

Since characteristics of domestic wastewater do not vary significantly, approximate capital cost may be assessed. For domestic wastewater, the capital cost varies from USD 275,000 – 415,000 per MLD in India for flows higher than 50 MLD. The capital cost decreases with increasing flow because of economies of scale. On the other hand,

with decreasing flows, the capital cost increases up to USD 415,000 – 690,000 per MLD.

Since industrial wastewater characteristics vary with industry operations, the cost for Effluent Treatment Plant (ETPs) will be site-specific. The illustrative costs are provided in Table 5.

Table 5: Illustrative Costs for ETPs in India

Industry	Flow	Capex (Typical) (in USD)	Opex/Month (Typical) (in USD)
Textile	2MLD	550,000 – 690,000	27,500 – 35,000
Pulp and Paper	1 MLD	450,000 – 500,000	9,700 – 12,400
Tannery	1 MLD	480,000 – 620,000	9,600 – 11,000
Pharma-Formulation Type	350 KLD	110,000 – 165,000	6,200 – 7,600

Source: Industry Consultations

3.1 Designation of users to participate in trading scheme	3.2 Establish the baseline	3.3 Notification of reuse targets	3.4 Install hardware for real-time monitoring and data capture	3.5 Data transmission and storage	3.6 Data validation through algorithms	3.7 Issuance of WRCs	3.8 Notification of the trading process	3.9 Set Pricing Guidelines	3.10 WRCs reporting and settlements	3.11 Renotification of users
---	----------------------------	-----------------------------------	--	-----------------------------------	--	----------------------	---	----------------------------	-------------------------------------	------------------------------

Water efficiency measures – Water Pinch Analysis (WPA)^{13,14}

Water pinch analysis (WPA) is a systematic technique for designing, optimization and retrofitting of energy, mass, and water recovery networks. It is used to reduce water consumption and wastewater generation through an integration of water-using activities or processes. A key target of WPA is to maximize water reuse and minimize the amount of wastewater. WPA considers water reuse opportunities by carefully analysing flows

and quality of different streams. Possible water reuse options are identified by matching different 'sources' (i.e., streams coming out of process carrying, often multiple, contaminants) and 'sinks' (i.e., streams going into processes that often have specific water quality requirements). The identified sources and sinks, together with their mass flow rates and water quality data, are encoded into the water pinch software and provides basis for the analysis.¹⁵

Industrial water minimization can be conducted by four main strategies, as described in Table 6.

Table 6: Strategies for water minimization

Strategy	Description
Process Changes	a) Replace technology b) Modify equipment operating conditions
Water Reuse	a) Reuse wastewater from operation as input to another process b) Water reuse reduces overall water withdrawal and wastewater volumes, but does not affect contaminant loads
Regenerative Reuse	a) Treat wastewater to reduce the level of contaminants and reuse it in other process b) Both volumes and contaminant loads are reduced
Regenerative Recycling	a) After regeneration, recycle water to the process from which it came b) Recycling tends to build up contaminants system

13. Adapted from Khezri SM, et al. Application of Water Pinch Technology for water and wastewater treatment minimization in Aluminium anodizing industries. International Journal of Environmental Science and Technology, 2010

14. Adapted from 'What is Water Pinch Analysis?'. Prof. Dominic Foo, University of Nottingham

15. Water Pinch Analysis, Confederation of Indian Industry-Triveni Water Institute

Studies should be done to investigate the most suitable approach for wastewater minimization. One approach is to develop a systematic water networks design using WPA to minimize the water usage and wastewater generation for the plant, wherein COD or any other parameter may be chosen as the main parameter. Then, an integrated design method may be applied, which will bring the engineering insight using WPA that can determine the minimum flowrate of the water usage and

minimize the water consumption and wastewater generation.

WPA provides multiple fit-for-purpose opportunities and facilitates multiple recycling and reuse options. The wastewater must be treated appropriately to meet the water quality for the specified reuse. WPA provides multiple options of mixing, treating and channelizing water for various uses.

Figure 18: Overview of Water Pinch Analysis

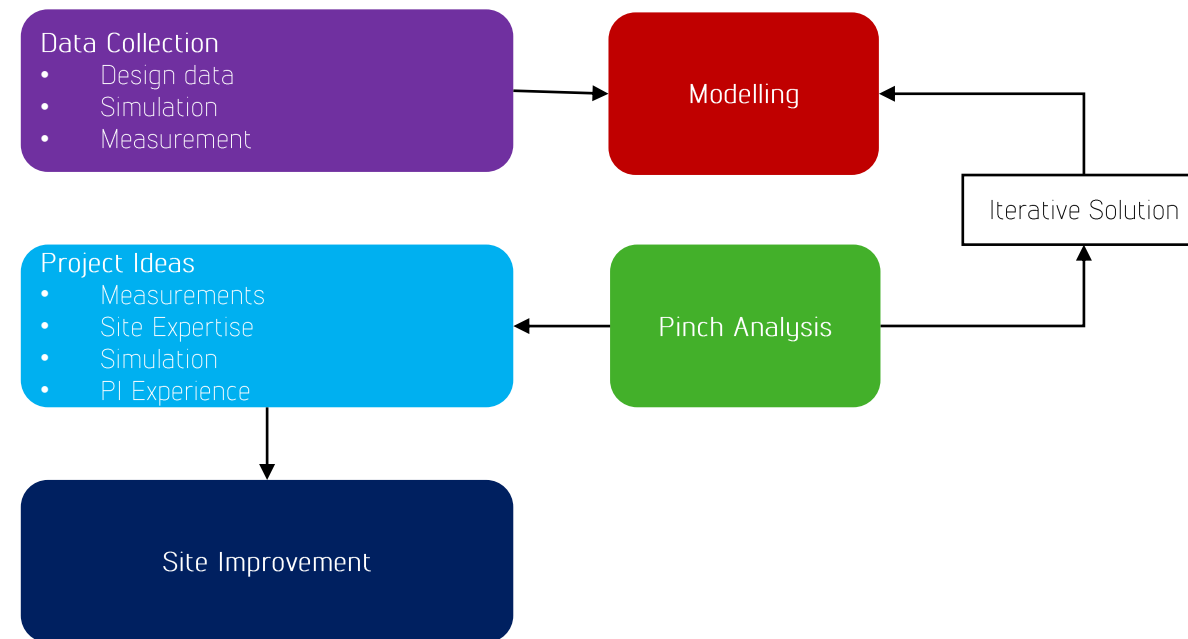

Source: Water Pinch Analysis, Confederation of Indian Industry-Triveni Water Institute

Setting reuse targets

Framework for setting reuse targets

Upon establishing the baseline for the users participating in the WRC scheme and assessing the prevalent treatment technologies in the specific geography, the Implementation Agency sets reuse targets for each user to achieve them within the specific WRC phase. These targets are set based on a transparent and statistical analysis.

Principle of cascading reuse targets

The Implementation Agency of the WRC scheme needs to define an overall reuse target, based on the economic assessment of the achievable potential for each sector to be achieved cumulatively by the selected users within the defined sector participating in the WRC trading scheme. Over successive phases of the WRC trading, the Implementation Agency may consistently increase the reuse targets based on the participation and results of the previous phases; thereby deliberately reducing total pollution and encouraging the users to undertake innovative reuse measures/technologies. This is necessary to promote technological innovations, as

technologies that are yet to be developed may hold the most cost-effective solution to wastewater treatment challenges.

Furthermore, each industry is categorized into sub-industries based on product types. For instance, thermal power plants can be categorized into coal-based, gas-based, and diesel-based, depending on the input fuel. A target shall then be set for each industrial sub-industry by apportioning the additional overall industrial wastewater target. So, this industry-wise target is allocated among sub-industries on a pro-rata basis of the total water withdrawal from the environment of the specific sub-industries. This cascading is done such that the sub-industry with the highest water withdrawal will be allotted the highest absolute wastewater reuse target. Hence, encouraging the water-guzzling sub-industries to ramp up its reuse infrastructure facilities at a faster rate to comply with the long-term vision for water security.

Further, within a specific industrial sub-industry, the individual industrial units shall set economically viable reuse targets and these targets are cascaded from the sub-industry targets. The broad approach of target setting is depicted in Figure 19.

Figure 19: Cascading of reuse targets

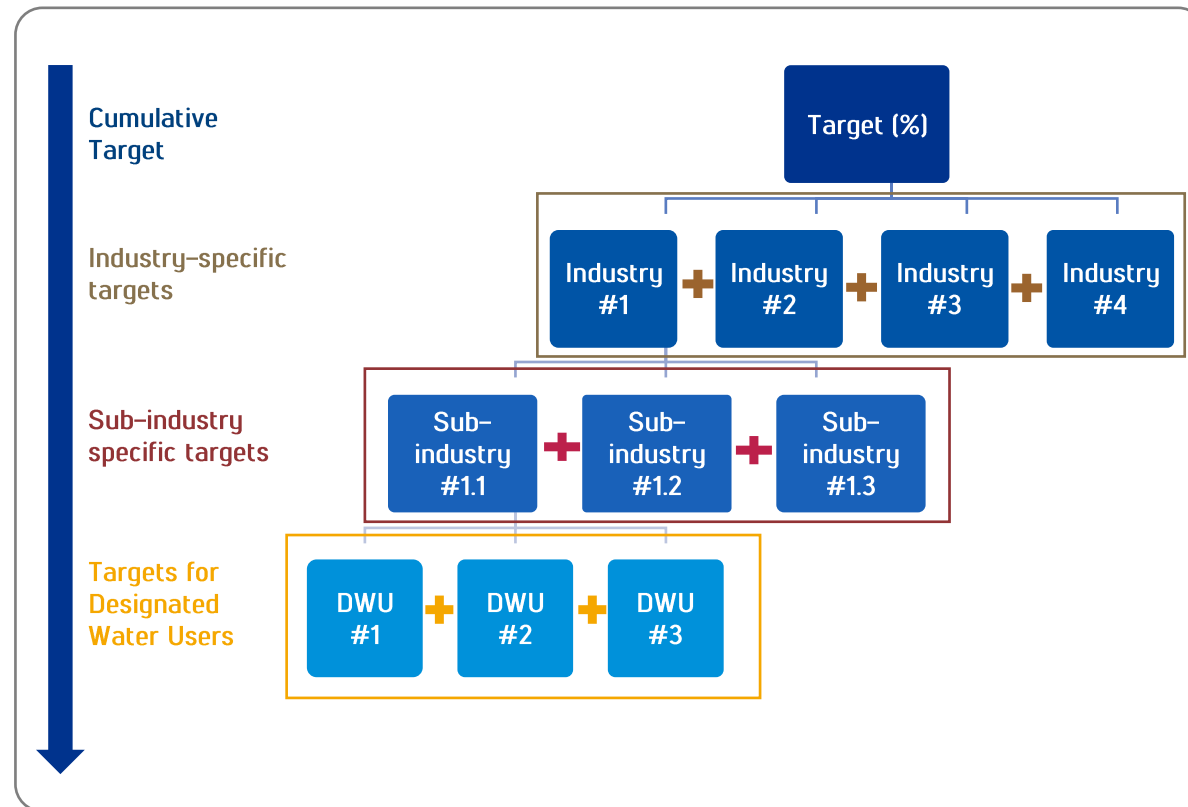

As depicted in in Figure 19, the cumulative target is cascaded to specific industries; which are further

cascaded to sub-industries and finally to the participating Designated Water Users.

Setting viable reuse targets

In pursuance of the principle of cascading reuse targets, the framework for setting targets for individual Designated Water Users is depicted in Figure 20.

Figure 20: Framework for setting reuse targets

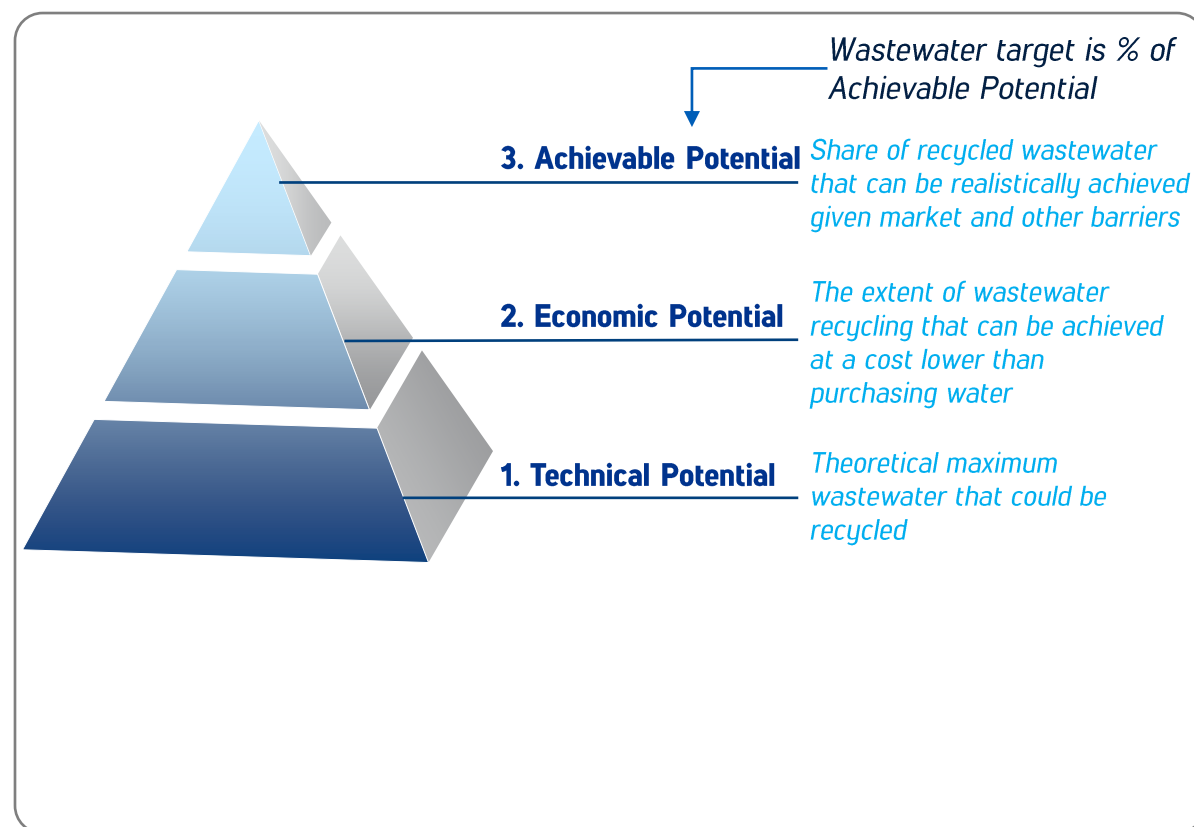

Setting economically viable reuse targets require understanding the existing level of technical innovation to reuse and recycle wastewater generated in a specific industry. Accordingly, the Technical Potential is assessed, to provide the potential level of possible reuse if all industrial users adopt the most efficient, commercially viable technologies and industrial practices, regardless of the cost. Technical Potential indicates the largest definition of wastewater reuse since it accounts for all reuse-efficient industrial processes, treatment technologies and practices existing in the market, disregarding all constraints related to cost effectiveness and willingness of Designated Water Users to adopt these measures.

While it is important to assess Technical Potential, it may not be economically viable for the Designated Water Users to achieve it. Accordingly, Economic Potential, a subset of Technical Potential, is defined as the wastewater reuse possible due to adoption of activities and measures that are the most efficient, commercially available, and cost-effective. To assess the cost-effectiveness, the incremental cost of adopting these measures is compared with the baseline and the savings from such measures are estimated. The estimated savings are those achieved against the current level of industrial water tariff. Only those technologies and measures where the net present value of the benefits exceeds the incremental costs to consumers are considered for assessing Economic Potential.

As a next step, the Achievable Potential is assessed, considering various barriers – market, societal and attitudinal. These barriers reflect the resistance among the Designated Water Users to adopt suitable measures in compliance of the WRC scheme.



3.1 Designation of users to participate in trading scheme	3.2 Establish the baseline	3.3 Notification of reuse targets	3.4 Install hardware for real-time monitoring and data capture	3.5 Data transmission and storage	3.6 Data validation through algorithms	3.7 Issuance of WRCs	3.8 Notification of the trading process	3.9 Set Pricing Guidelines	3.10 WRCs reporting and settlements	3.11 Renotification of users
---	----------------------------	-----------------------------------	--	-----------------------------------	--	----------------------	---	----------------------------	-------------------------------------	------------------------------

There are a wide range of measures that a Designated Water User may adopt to reduce freshwater consumption and promote consumption of recycled wastewater. Yet, it is critical to assess the most economically efficient option. Accordingly, to provide a quantitative basis for assessing the cost-efficiency

of the measures and to arrive at the Achievable Potential for reuse, the cost of the individual measures is estimated, and a cost curve is developed. An indicative cost curve of possible measures is provided in Figure 21.

Figure 21: Indicative Cost Curve for wastewater reuse measures

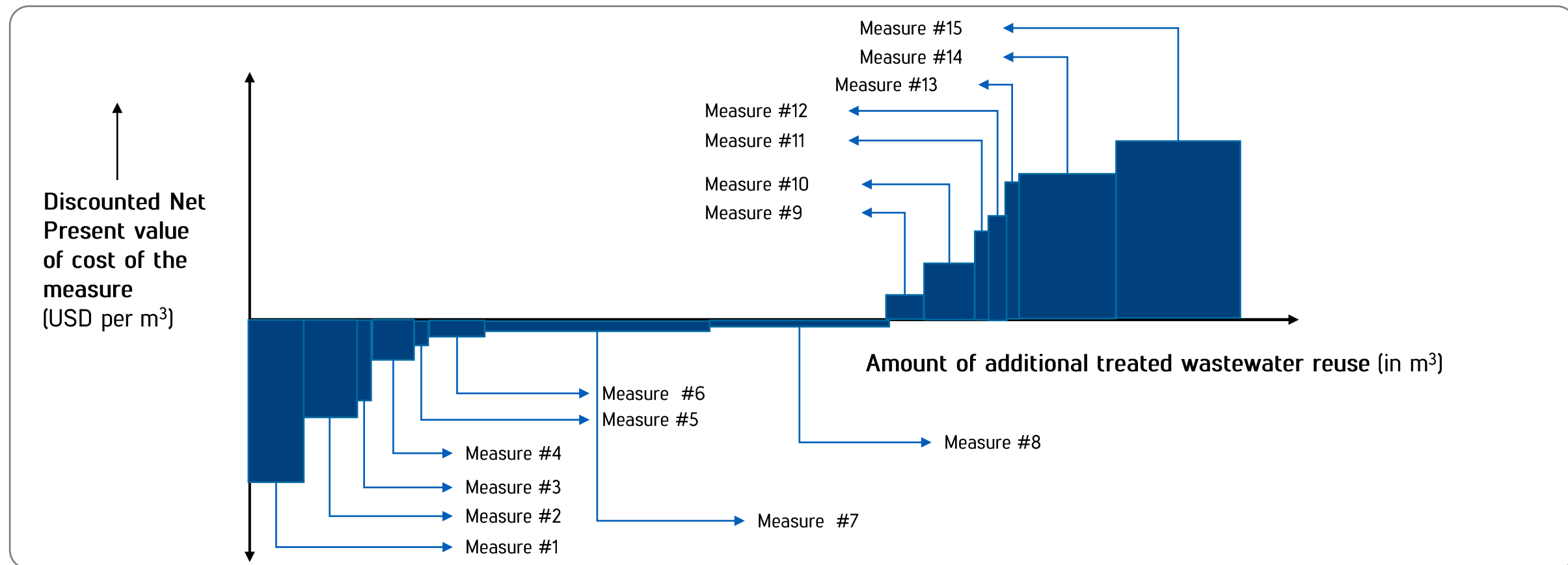



3.1 Designation of users to participate in trading scheme

3.2 Establish the baseline

3.3 Notification of reuse targets

3.4 Install hardware for real-time monitoring and data capture

3.5 Data transmission and storage

3.6 Data validation through algorithms

3.7 Issuance of WRCs

3.8 Notification of the trading process

3.9 Set Pricing Guidelines

3.10 WRCs reporting and settlements

3.11 Renotification of users

In Figure 21, each rectangle represents a specific measure in the industry/ sub-industry to increase the level of wastewater reuse.

- The breadth of each bar (along the horizontal axis) represents the quantum of additional treated wastewater (in m³)
- The height of the bar (along the vertical axis) represents the Discounted Net Present Value of the cost of measure (in USD per m³). The Discounted Net Present value of the cost is defined as: = (Discounted Present Value of Cost – Discounted Present value of savings)

- The area of each bar (length * breadth) represents the total net cost of the respective measure, and the sum of the areas of the bars represents the total net cost for all measures.

Hence, the least expensive measures are those with a negative net cost where the savings are greater than the cost; these are the measures that lay below the vertical axis in Figure 21. As evident in Figure 21, the cost-effectiveness of reuse measures reduces from left to right.

From the developed cost curve, Achievable Potential will be the amount of additional

wastewater reuse till the level where the sum of the Discounted NPV of the cumulative costs of the measures is sustainable for the business.

Methodology to set reuse targets

When setting reuse targets, the cost curve for the industry as a whole or at a sub-industry level (depending on the heterogeneity of the product type) needs to be established to identify the achievable potential of wastewater reuse before cascading to the designated user levels. However, while cascading the targets, it is important to

push the least efficient industry/ sub-industry/ Designated Water User to ramp up its reuse infrastructure facilities at a faster rate.

Cascading cumulative targets to industry-specific targets

The cumulative target is cascaded to industry-specific targets in such a manner that the industry with the highest water withdrawal from the environment is given the highest absolute wastewater reuse target. The algorithm is elaborated with an example in Table 7.

Table 7: Methodology to set industry-specific reuse targets

S.No.	Step	Illustrative Example																		
1	Collate baseline industry-wise water consumption and wastewater generation data.	<p>Consider that the cumulative target must be cascaded to 5 industries, with baseline data as provided.</p> <p>Baseline data (in m³)</p> <table border="1"> <caption>Baseline Data (in m³)</caption> <thead> <tr> <th>Industry</th> <th>Average annual wastewater generated</th> <th>Average annual water withdrawal from environment</th> </tr> </thead> <tbody> <tr> <td>Industry 5</td> <td>0.0075</td> <td>0.15</td> </tr> <tr> <td>Industry 4</td> <td>0.0350</td> <td>0.35</td> </tr> <tr> <td>Industry 3</td> <td>0.0600</td> <td>0.20</td> </tr> <tr> <td>Industry 2</td> <td>0.2600</td> <td>1.30</td> </tr> <tr> <td>Industry 1</td> <td>0.4500</td> <td>3.00</td> </tr> </tbody> </table>	Industry	Average annual wastewater generated	Average annual water withdrawal from environment	Industry 5	0.0075	0.15	Industry 4	0.0350	0.35	Industry 3	0.0600	0.20	Industry 2	0.2600	1.30	Industry 1	0.4500	3.00
Industry	Average annual wastewater generated	Average annual water withdrawal from environment																		
Industry 5	0.0075	0.15																		
Industry 4	0.0350	0.35																		
Industry 3	0.0600	0.20																		
Industry 2	0.2600	1.30																		
Industry 1	0.4500	3.00																		

3.1 Designation of users to participate in trading scheme	3.2 Establish the baseline	3.3 Notification of reuse targets	3.4 Install hardware for real-time monitoring and data capture	3.5 Data transmission and storage	3.6 Data validation through algorithms	3.7 Issuance of WRCs	3.8 Notification of the trading process	3.9 Set Pricing Guidelines	3.10 WRCs reporting and settlements	3.11 Renotification of users
---	----------------------------	-----------------------------------	--	-----------------------------------	--	----------------------	---	----------------------------	-------------------------------------	------------------------------

S.No.	Step	Illustrative Example																		
2	Consider the cumulative target and accordingly, calculate the cumulative wastewater reuse target based on the cumulative wastewater generated.	Now, based on the baseline data: Total wastewater generated = $0.8125 \times 10^9 \text{ m}^3$ Considering the cumulative target of 20% to be cascaded to these 5 industries, the cumulative wastewater reuse target is: $= 20\% \times 0.8125 \times 10^9 = 0.1625 \times 10^9 \text{ m}^3$																		
3	Estimate the wastewater reuse target for each industry by using the formula: <i>Percentage of water withdrawal * Cumulative wastewater reuse target</i>	<p>The industry-specific % of water withdrawal and the respective absolute reuse targets are as follows:</p> <table border="1"> <thead> <tr> <th>Industry #</th> <th>% water withdrawal</th> <th>Reuse target ($\times 10^9 \text{ m}^3$)</th> </tr> </thead> <tbody> <tr> <td>Industry #1</td> <td>60%</td> <td>$= 60\% \times 0.1625 = 0.098$</td> </tr> <tr> <td>Industry #2</td> <td>26%</td> <td>0.042</td> </tr> <tr> <td>Industry #3</td> <td>4%</td> <td>0.007</td> </tr> <tr> <td>Industry #4</td> <td>7%</td> <td>0.011</td> </tr> <tr> <td>Industry #5</td> <td>3%</td> <td>0.005</td> </tr> </tbody> </table> <p>As evident from the table above, Industry 1 has the highest water withdrawal, and is accordingly set the highest absolute wastewater reuse target.</p>	Industry #	% water withdrawal	Reuse target ($\times 10^9 \text{ m}^3$)	Industry #1	60%	$= 60\% \times 0.1625 = 0.098$	Industry #2	26%	0.042	Industry #3	4%	0.007	Industry #4	7%	0.011	Industry #5	3%	0.005
Industry #	% water withdrawal	Reuse target ($\times 10^9 \text{ m}^3$)																		
Industry #1	60%	$= 60\% \times 0.1625 = 0.098$																		
Industry #2	26%	0.042																		
Industry #3	4%	0.007																		
Industry #4	7%	0.011																		
Industry #5	3%	0.005																		

Note: The targets will account for the most efficient industrial processes considering minimization techniques like Water Pinch Analysis, best available technologies, and practices specific to the industry.

Cascading industry-specific targets to sub-industry targets

The industry-specific target is then cascaded to individual sub-industries. Like the algorithm for setting industry-specific targets, the sub-industry targets are set so that the sub-industry with the highest

water withdrawal from the environment is given the highest absolute wastewater reuse target. The algorithm is elaborated with an example in Table 8.



3.1 Designation of users to participate in trading scheme	3.2 Establish the baseline	3.3 Notification of reuse targets	3.4 Install hardware for real-time monitoring and data capture	3.5 Data transmission and storage	3.6 Data validation through algorithms	3.7 Issuance of WRCs	3.8 Notification of the trading process	3.9 Set Pricing Guidelines	3.10 WRCs reporting and settlements	3.11 Renotification of users
---	----------------------------	-----------------------------------	--	-----------------------------------	--	----------------------	---	----------------------------	-------------------------------------	------------------------------

Table 8: Methodology to set sub-industry specific reuse targets

S.No.	Step	Illustrative Example															
1	Collate baseline sub-industry wise water consumption and wastewater generation data.	<p>Consider that the cumulative target must be cascaded to 4 sub-industries, with baseline data as provided.</p> <table border="1"> <caption>Baseline data (in m³)</caption> <thead> <tr> <th>Sub-industry</th> <th>Average annual wastewater generated</th> <th>Average annual water withdrawal from environment</th> </tr> </thead> <tbody> <tr> <td>Sub-industry 4</td> <td>3,996</td> <td>5,213</td> </tr> <tr> <td>Sub-industry 3</td> <td>4,250</td> <td>5,670</td> </tr> <tr> <td>Sub-industry 2</td> <td>3,000</td> <td>3,958</td> </tr> <tr> <td>Sub-industry 1</td> <td>5,200</td> <td>6,500</td> </tr> </tbody> </table>	Sub-industry	Average annual wastewater generated	Average annual water withdrawal from environment	Sub-industry 4	3,996	5,213	Sub-industry 3	4,250	5,670	Sub-industry 2	3,000	3,958	Sub-industry 1	5,200	6,500
Sub-industry	Average annual wastewater generated	Average annual water withdrawal from environment															
Sub-industry 4	3,996	5,213															
Sub-industry 3	4,250	5,670															
Sub-industry 2	3,000	3,958															
Sub-industry 1	5,200	6,500															
2	<p>Estimate the wastewater reuse target for each sub-industry by using the formula: (% of water withdrawal by the sub-industry * absolute industry-specific wastewater reuse target).</p>	<p>Considering that the wastewater to be reused cumulatively by the industry is 4,111.5 m³. The sub-industry % of water withdrawal and the respective absolute reuse targets are as follows:</p> <table border="1"> <thead> <tr> <th>Industry #</th> <th>% water withdrawal</th> <th>Reuse target (x 10⁹ m³)</th> </tr> </thead> <tbody> <tr> <td>Sub-industry #1</td> <td>30.46%</td> <td>= 30.46%* 4,111.5 = 1,252</td> </tr> <tr> <td>Sub-industry #2</td> <td>18.55%</td> <td>763</td> </tr> <tr> <td>Sub-industry #3</td> <td>26.57%</td> <td>1,092</td> </tr> <tr> <td>Sub-industry #4</td> <td>24.43%</td> <td>1,004</td> </tr> </tbody> </table> <p>As evident from the table above, Sub-industry 1 has the highest water withdrawal, and is accordingly set the highest absolute wastewater reuse target.</p>	Industry #	% water withdrawal	Reuse target (x 10 ⁹ m ³)	Sub-industry #1	30.46%	= 30.46%* 4,111.5 = 1,252	Sub-industry #2	18.55%	763	Sub-industry #3	26.57%	1,092	Sub-industry #4	24.43%	1,004
Industry #	% water withdrawal	Reuse target (x 10 ⁹ m ³)															
Sub-industry #1	30.46%	= 30.46%* 4,111.5 = 1,252															
Sub-industry #2	18.55%	763															
Sub-industry #3	26.57%	1,092															
Sub-industry #4	24.43%	1,004															

Cascading sub-industry targets to individual Designated Water Users

Further, while cascading sub-industry targets to individual Designated Water Users, the user with the highest specific water withdrawal shall be given the highest percentage of the total additional

wastewater reuse target. Accordingly, the Implementation Agency shall set and notify reuse targets for the Designated Water Users participating in the WRC scheme. The methodology to set reuse targets for the two major types of Designated Water Users is discussed below.





3.1 Designation of users to participate in trading scheme

3.2 Establish the baseline

3.3 Notification of reuse targets

3.4 Install hardware for real-time monitoring and data capture

3.5 Data transmission and storage

3.6 Data validation through algorithms

3.7 Issuance of WRCs

3.8 Notification of the trading process

3.9 Set Pricing Guidelines

3.10 WRCs reporting and settlements

3.11 Renotification of users

Case I: Textile unit in an industrial park in Bangladesh

We assume that the overall reuse target for the textile wet processing sub-industry, under the textile dyeing and finishing industry, in a specific geography is 50%. This reuse target is cascaded amongst the various Designated Water Users. We considered the baseline data obtained from one such industrial unit in Bangladesh.

In Bangladesh, the specific water consumption

for textile users ranges from 25 to 180 L/kg of fabric, with some units having a specific water consumption as high as 400 L/kg¹⁶. Further, of the total water used in wet dyeing and finishing facilities, nearly 72%¹⁷ of the water used is process water which then ends up as wastewater, with wastewater generated ranging from 18 – 130L/ kg of fabric.

There is enormous potential for wastewater reuse in a textile unit. For instance, as a good practice example, Zero Liquid Discharge has been implemented in the Tirupur Textile Industry Cluster (India), where nine CETPs with cumulative capacity of 53 MLD have been established, with 95–98% of the water being reused. In this cluster, the direct re-use of

treated brine in the dyeing process reduces the need for the thermal evaporator system. Hence, the theoretical potential for reuse among textile wet processing units is assumed as 98%. The algorithm for setting reuse targets for industrial units is elaborated with an example in Table 9.

Table 9: Methodology to set reuse targets for industrial units

S.No.	Step	Illustrative Example																				
1	Collate baseline water data for individual plants.	<p>Consider four textile units, belonging to the textile wet processing sub-industry and with similar product types, participating in the WRC scheme.</p> <p style="text-align: center;">Baseline data (in m³)</p> <table border="1"> <thead> <tr> <th>Plant</th> <th>Average water withdrawal</th> <th>Average wastewater generated</th> <th>Average wastewater reused</th> </tr> </thead> <tbody> <tr> <td>Plant 4</td> <td>1,920,000</td> <td>1,344,000</td> <td>201,600</td> </tr> <tr> <td>Plant 3</td> <td>22,500,000</td> <td>14,625,000</td> <td>1,023,750</td> </tr> <tr> <td>Plant 2</td> <td>5,600,000</td> <td>4,200,000</td> <td>420,000</td> </tr> <tr> <td>Plant 1</td> <td>5,298,939</td> <td>3,236,022</td> <td>97,081</td> </tr> </tbody> </table>	Plant	Average water withdrawal	Average wastewater generated	Average wastewater reused	Plant 4	1,920,000	1,344,000	201,600	Plant 3	22,500,000	14,625,000	1,023,750	Plant 2	5,600,000	4,200,000	420,000	Plant 1	5,298,939	3,236,022	97,081
Plant	Average water withdrawal	Average wastewater generated	Average wastewater reused																			
Plant 4	1,920,000	1,344,000	201,600																			
Plant 3	22,500,000	14,625,000	1,023,750																			
Plant 2	5,600,000	4,200,000	420,000																			
Plant 1	5,298,939	3,236,022	97,081																			

16. 'Wastewater Treatment Technologies: ZHDC – The Roadmap to Zero Programme', International Finance Corporation

17. 'Wastewater Treatment Technologies: ZHDC – The Roadmap to Zero Programme', International Finance Corporation





3.1 Designation of users to participate in trading scheme

3.2 Establish the baseline

3.3 Notification of reuse targets

3.4 Install hardware for real-time monitoring and data capture

3.5 Data transmission and storage

3.6 Data validation through algorithms

3.7 Issuance of WRCs

3.8 Notification of the trading process

3.9 Set Pricing Guidelines

3.10 WRCs reporting and settlements

3.11 Renotification of users

Case I: Textile unit in an industrial park in Bangladesh

S.No.	Step	Illustrative Example										
2	Assess the Theoretical Reuse Potential for the respective plant (P_t), based on existing technologies and plant process flow for comparable sub-industry and product types	<p>$P_t = 98\%$, for the textile wet processing sub-industry (as discussed earlier).</p> <p>The Theoretical Reuse Potential will account for the most efficient industrial processes considering minimization techniques like Water Pinch Analysis, best available technologies, and practices specific to the sub-industry.</p>										
3	<p>Assess the baseline wastewater reuse percentage for the respective plant (P_c) and compare it with the Theoretical Reuse Potential (P_t).</p> <p>$P_c = \text{baseline wastewater reused} / \text{baseline wastewater generated}$</p> <p>Accordingly,</p> <p>i. If $P_c = P_t$, then the plant is at its most efficient state, and no further reuse is possible.</p> <p>ii. If $P_c < P_t$, then additional analysis is to be performed.</p>	<p>The baseline levels of reuse for these four units is as follows:</p> <table border="1"> <thead> <tr> <th>Textile unit</th> <th>Baseline reuse</th> </tr> </thead> <tbody> <tr> <td>User #1</td> <td>8%</td> </tr> <tr> <td>User #2</td> <td>10%</td> </tr> <tr> <td>User #3</td> <td>7%</td> </tr> <tr> <td>User #4</td> <td>15%</td> </tr> </tbody> </table> <p>As $P_t = 98\%$, there is potential for additional reuse for each of the users.</p>	Textile unit	Baseline reuse	User #1	8%	User #2	10%	User #3	7%	User #4	15%
Textile unit	Baseline reuse											
User #1	8%											
User #2	10%											
User #3	7%											
User #4	15%											



Case I: Textile unit in an industrial park in Bangladesh

S.No.	Step	Illustrative Example										
4	<p>Compute the baseline specific water withdrawal from the environment for each unit (S_w) and identify the unit with least baseline specific water withdrawal in the industry.</p> <p>S_w = Baseline water withdrawal (m³) / baseline production (tonne)</p>	<p>The baseline specific water withdrawal for each textile unit is as depicted.</p> <table border="1"> <caption>Specific water withdrawal data</caption> <thead> <tr> <th>Plant</th> <th>Specific water withdrawal</th> </tr> </thead> <tbody> <tr> <td>Plant 4</td> <td>120.0</td> </tr> <tr> <td>Plant 3</td> <td>250.0</td> </tr> <tr> <td>Plant 2</td> <td>280.0</td> </tr> <tr> <td>Plant 1</td> <td>167.2</td> </tr> </tbody> </table>	Plant	Specific water withdrawal	Plant 4	120.0	Plant 3	250.0	Plant 2	280.0	Plant 1	167.2
Plant	Specific water withdrawal											
Plant 4	120.0											
Plant 3	250.0											
Plant 2	280.0											
Plant 1	167.2											

Case I: Textile unit in an industrial park in Bangladesh

S.No.	Step	Illustrative Example										
5	<p>Compute the relative specific water withdrawal (RF) for each industrial unit by dividing the respective specific water withdrawal by that of the least specific water withdrawal in that sub-industry.</p> <p>RF of the Designated User = S_w of the respective plant / minimum (S_w)</p>	<p>The relative specific water withdrawal for each textile unit is as depicted.</p> <table border="1"> <caption>Relative Specific water withdrawal</caption> <thead> <tr> <th>Plant</th> <th>Relative Specific water withdrawal</th> </tr> </thead> <tbody> <tr> <td>Plant 4</td> <td>1.000</td> </tr> <tr> <td>Plant 3</td> <td>2.083</td> </tr> <tr> <td>Plant 2</td> <td>2.333</td> </tr> <tr> <td>Plant 1</td> <td>1.393</td> </tr> </tbody> </table>	Plant	Relative Specific water withdrawal	Plant 4	1.000	Plant 3	2.083	Plant 2	2.333	Plant 1	1.393
Plant	Relative Specific water withdrawal											
Plant 4	1.000											
Plant 3	2.083											
Plant 2	2.333											
Plant 1	1.393											

Case I: Textile unit in an industrial park in Bangladesh

S.No.	Step	Illustrative Example																																			
6	<p>This sub-industry target is allocated on a pro-rata basis to different users of that sub-industry based on the total specific water withdrawal i.e., higher the specific water withdrawal of a particular user, higher the target set.</p> <p>Accordingly,</p> $\text{Additional wastewater reuse percentage of a plant} = RF * \frac{\text{Total sub - industry additional reuse}}{\sum\{(RF) * (\text{Wastewater generated})\}}$ <p>Where</p> <p>Total sub-industry additional reuse is the additional wastewater to be reused to reach the sub-industry target. This is computed as:</p> $= (\text{Sub-industry wastewater to be reused in target year}) - (\text{Sub-industry wastewater reused in baseline year})$ $= (\text{Sub-industry target} * \text{Sub-industry baseline wastewater generated}) - (\text{Sub-industry wastewater reused in baseline year})$ <p>So, for each designated water user, P_a is computed. Accordingly, the cascaded wastewater reuse target (P_{casc}) is obtained as: $P_c + P_a$.</p>	<p>Let us consider the sub-industry target to be 50%. Then, the additional and cascaded wastewater reuse percentage target is as follows:</p> <table border="1"> <caption>Cascaded Wastewater Reuse Targets</caption> <thead> <tr> <th>Plant</th> <th>Baseline wastewater reuse (P_c)</th> <th>Additional target for user (P_a)</th> <th>Cascaded target (P_{casc})</th> </tr> </thead> <tbody> <tr> <td>Plant 4</td> <td>15%</td> <td>22%</td> <td>37%</td> </tr> <tr> <td>Plant 3</td> <td>7%</td> <td>45%</td> <td>52%</td> </tr> <tr> <td>Plant 2</td> <td>10%</td> <td>50%</td> <td>60%</td> </tr> <tr> <td>Plant 1</td> <td>3%</td> <td>30%</td> <td>33%</td> </tr> </tbody> </table> <p>As evident from the graph below, greater the RF, greater the P_a.</p> <table border="1"> <caption>RF vs. Additional Wastewater Reuse Percentage</caption> <thead> <tr> <th>Plant</th> <th>Relative Specific Water Consumption (RF)</th> <th>Additional Wastewater Reuse Percentage</th> </tr> </thead> <tbody> <tr> <td>Plant 4</td> <td>1.00</td> <td>22%</td> </tr> <tr> <td>Plant 1</td> <td>1.39</td> <td>30%</td> </tr> <tr> <td>Plant 3</td> <td>2.08</td> <td>45%</td> </tr> <tr> <td>Plant 2</td> <td>2.33</td> <td>50%</td> </tr> </tbody> </table>	Plant	Baseline wastewater reuse (P_c)	Additional target for user (P_a)	Cascaded target (P_{casc})	Plant 4	15%	22%	37%	Plant 3	7%	45%	52%	Plant 2	10%	50%	60%	Plant 1	3%	30%	33%	Plant	Relative Specific Water Consumption (RF)	Additional Wastewater Reuse Percentage	Plant 4	1.00	22%	Plant 1	1.39	30%	Plant 3	2.08	45%	Plant 2	2.33	50%
Plant	Baseline wastewater reuse (P_c)	Additional target for user (P_a)	Cascaded target (P_{casc})																																		
Plant 4	15%	22%	37%																																		
Plant 3	7%	45%	52%																																		
Plant 2	10%	50%	60%																																		
Plant 1	3%	30%	33%																																		
Plant	Relative Specific Water Consumption (RF)	Additional Wastewater Reuse Percentage																																			
Plant 4	1.00	22%																																			
Plant 1	1.39	30%																																			
Plant 3	2.08	45%																																			
Plant 2	2.33	50%																																			

Case I: Textile unit in an industrial park in Bangladesh

S.No.	Step	Illustrative Example
7	<p>Assess the economic rationale of the investments needed to achieve P_{casc} If at P_{casc}</p> <p>i. Levelized cost of treating and reusing wastewater \leq the average cost for water production (including transmission and distribution), then the plant-level reuse target is fixed at P_{casc}</p>	<p>Case I: Here, the reuse target is the same as cascaded wastewater reuse.</p>

Case I: Textile unit in an industrial park in Bangladesh

S.No.	Step	Illustrative Example
7	ii. Levelized cost of treating and reusing wastewater > the average cost for water production, then the plant level reuse target is fixed at an appropriate value between P_c and P_{casc} , where the levelized cost of treating and reusing wastewater is just less than the average cost of water production.	<p>Case II: Here, the reuse target is arrived at by undertaking scenario analysis and computing the value of percentage of wastewater reuse where the levelized cost is just less than the average cost of production.</p>



3.1 Designation of users to participate in trading scheme

3.2 Establish the baseline

3.3 Notification of reuse targets

3.4 Install hardware for real-time monitoring and data capture

3.5 Data transmission and storage

3.6 Data validation through algorithms

3.7 Issuance of WRCs

3.8 Notification of the trading process

3.9 Set Pricing Guidelines

3.10 WRCs reporting and settlements

3.11 Renotification of users

Case I: Textile unit in an industrial park in Bangladesh

S.No.	Step	Illustrative Example																														
		Hence, the reuse targets set will account for cost-effectiveness of the targets and considering the availability of the technologies in the market, with the cost of the technologies reflecting the barriers, if any.																														
8	Arrive at the overall industry unit-level targets based on economic potential of achieving P_{casc}	<p>Based on values for levelized cost and cost of production, the targets for the five individual industrial units are as follows:</p> <table border="1"> <thead> <tr> <th>Plant</th> <th>P_c</th> <th>P_{casc}</th> <th>At P_{casc} levelized cost</th> <th>Cost of production of water</th> <th>P_{target}</th> </tr> </thead> <tbody> <tr> <td>Plant 1</td> <td>3%</td> <td>33%</td> <td>\$0.27/ kL</td> <td>\$0.31/ kL</td> <td>33%</td> </tr> <tr> <td>Plant 2</td> <td>10%</td> <td>60%</td> <td>\$0.30/ kL</td> <td>\$0.35/ kL</td> <td>60%</td> </tr> <tr> <td>Plant 3</td> <td>7%</td> <td>52%</td> <td>\$0.31/ kL</td> <td>\$0.33/ kL</td> <td>52%</td> </tr> <tr> <td>Plant 4</td> <td>15%</td> <td>37%</td> <td>\$0.34/ kL</td> <td>\$0.28/ kL</td> <td>30%</td> </tr> </tbody> </table> <p>For instance, Plant 3 was set a reuse target of 52%. To achieve this reuse target, its levelized cost of recycled wastewater is less than the cost of production of water; accordingly, this cascaded target is economically viable for Plant 3. Hence, the reuse target for Plant 3 is 52%.</p>	Plant	P_c	P_{casc}	At P_{casc} levelized cost	Cost of production of water	P_{target}	Plant 1	3%	33%	\$0.27/ kL	\$0.31/ kL	33%	Plant 2	10%	60%	\$0.30/ kL	\$0.35/ kL	60%	Plant 3	7%	52%	\$0.31/ kL	\$0.33/ kL	52%	Plant 4	15%	37%	\$0.34/ kL	\$0.28/ kL	30%
Plant	P_c	P_{casc}	At P_{casc} levelized cost	Cost of production of water	P_{target}																											
Plant 1	3%	33%	\$0.27/ kL	\$0.31/ kL	33%																											
Plant 2	10%	60%	\$0.30/ kL	\$0.35/ kL	60%																											
Plant 3	7%	52%	\$0.31/ kL	\$0.33/ kL	52%																											
Plant 4	15%	37%	\$0.34/ kL	\$0.28/ kL	30%																											





3.1 Designation of users to participate in trading scheme

3.2 Establish the baseline

3.3 Notification of reuse targets

3.4 Install hardware for real-time monitoring and data capture

3.5 Data transmission and storage

3.6 Data validation through algorithms

3.7 Issuance of WRCs

3.8 Notification of the trading process

3.9 Set Pricing Guidelines

3.10 WRCs reporting and settlements

3.11 Renotification of users

Case II: Urban Local Body

Consider the target setting for an Urban Local Body (ULB) in India. The per capita water consumption for a ULB in India ranges between 70 to 150 lpcd and the wastewater generated is nearly 80% of the total water consumption.

There is an enormous potential for wastewater reuse in ULBs. For instance, supply of 90 MLD of tertiary treated municipal wastewater to nearby industrial clusters by Chennai Metropolitan Water Supply and Sewerage Board (India) at

Koyambedu and Kodungaiyur is leading to freshwater savings of around 40 MLD and revenue generation of approx. USD 9 mn. Likewise, reuse practices and technologies may be adopted by other ULBs to reduce their

dependency on freshwater. The algorithm for setting reuse targets for ULBs is elaborated with an example in Table 10.

Table 10: Methodology to set reuse targets for ULBs

S.No.	Step	Illustrative Example																				
1	Collate baseline water data for individual Urban Local Bodies.	<p>Consider four Urban Local Bodies participating in the WRC scheme.</p> <p>Baseline data (in MLD)</p> <table border="1"> <caption>Baseline data (in MLD)</caption> <thead> <tr> <th>ULB</th> <th>Wastewater reuse</th> <th>Wastewater generation</th> <th>Freshwater consumption</th> </tr> </thead> <tbody> <tr> <td>ULB 1</td> <td>90.00</td> <td>640</td> <td>802</td> </tr> <tr> <td>ULB 2</td> <td>4.50</td> <td>90</td> <td>112</td> </tr> <tr> <td>ULB 3</td> <td>14.40</td> <td>144</td> <td>180</td> </tr> <tr> <td>ULB 4</td> <td>6.32</td> <td>79</td> <td>99</td> </tr> </tbody> </table>	ULB	Wastewater reuse	Wastewater generation	Freshwater consumption	ULB 1	90.00	640	802	ULB 2	4.50	90	112	ULB 3	14.40	144	180	ULB 4	6.32	79	99
ULB	Wastewater reuse	Wastewater generation	Freshwater consumption																			
ULB 1	90.00	640	802																			
ULB 2	4.50	90	112																			
ULB 3	14.40	144	180																			
ULB 4	6.32	79	99																			



Case II: Urban Local Body

S.No.	Step	Illustrative Example															
2	<p>Assess the Theoretical Reuse Potential for the respective ULB (ULB_t) based on:</p> <ul style="list-style-type: none"> i. Possible users of treated wastewater within the defined boundary of ULB. ii. Possible demand for reused water for these identified users. 	<p>The theoretical reuse potential (ULB_t) for the four ULBs is as follows:</p> <table border="1"> <thead> <tr> <th>ULB unit</th> <th>Theoretical reuse</th> </tr> </thead> <tbody> <tr> <td>ULB #1</td> <td>65%</td> </tr> <tr> <td>ULB #2</td> <td>50%</td> </tr> <tr> <td>ULB #3</td> <td>40%</td> </tr> <tr> <td>ULB #4</td> <td>60%</td> </tr> </tbody> </table>	ULB unit	Theoretical reuse	ULB #1	65%	ULB #2	50%	ULB #3	40%	ULB #4	60%					
ULB unit	Theoretical reuse																
ULB #1	65%																
ULB #2	50%																
ULB #3	40%																
ULB #4	60%																
3	<p>Assess the baseline wastewater reuse percentage for the respective plant (ULB_c) and compare it with the ULB_t.</p> <p>$ULB_c = \text{baseline wastewater reused} / \text{baseline wastewater generated}$</p> <p>Accordingly,</p> <ul style="list-style-type: none"> i. If $ULB_c = ULB_t$ then the plant is at its most efficient state, and no further reuse is possible. ii. If $ULB_c < ULB_t$, then economic cost-benefit analysis is to be performed. 	<p>The current wastewater reuse (ULB_c) versus theoretical percentage wastewater usage (ULB_t) for the four ULBs is as depicted:</p> <table border="1"> <thead> <tr> <th>ULB</th> <th>Theoretical reuse %</th> <th>Baseline reuse %</th> </tr> </thead> <tbody> <tr> <td>ULB 1</td> <td>65%</td> <td>14%</td> </tr> <tr> <td>ULB 2</td> <td>50%</td> <td>5%</td> </tr> <tr> <td>ULB 3</td> <td>40%</td> <td>10%</td> </tr> <tr> <td>ULB 4</td> <td>60%</td> <td>8%</td> </tr> </tbody> </table>	ULB	Theoretical reuse %	Baseline reuse %	ULB 1	65%	14%	ULB 2	50%	5%	ULB 3	40%	10%	ULB 4	60%	8%
ULB	Theoretical reuse %	Baseline reuse %															
ULB 1	65%	14%															
ULB 2	50%	5%															
ULB 3	40%	10%															
ULB 4	60%	8%															

Case II: Urban Local Body

S.No.	Step	Illustrative Example															
4	Assess the economic rationale of the investments needed to achieve ULB_t If at ULB_t : i. Levelized cost of treating and reusing wastewater \leq the average cost for freshwater production (including transmission and distribution), then the ULB level reuse percentage target is fixed at ULB_t .	The levelized cost of treating and reusing wastewater and average cost for freshwater production is as follows: <table border="1"> <thead> <tr> <th>ULB unit</th> <th>Levelized cost of treating and reusing wastewater at ULB_t (in USD/m³)</th> <th>Average cost of freshwater production including transmission and distribution at ULB_t (in USD/m³)</th> </tr> </thead> <tbody> <tr> <td>ULB #1</td> <td>0.37</td> <td>0.40</td> </tr> <tr> <td>ULB #2</td> <td>0.27</td> <td>0.20</td> </tr> <tr> <td>ULB #3</td> <td>0.33</td> <td>0.31</td> </tr> <tr> <td>ULB #4</td> <td>0.27</td> <td>0.32</td> </tr> </tbody> </table> <p>Case I (as in ULB #1 & ULB #4): Here, the reuse target is the same as theoretical wastewater reuse.</p>	ULB unit	Levelized cost of treating and reusing wastewater at ULB_t (in USD/m ³)	Average cost of freshwater production including transmission and distribution at ULB_t (in USD/m ³)	ULB #1	0.37	0.40	ULB #2	0.27	0.20	ULB #3	0.33	0.31	ULB #4	0.27	0.32
ULB unit	Levelized cost of treating and reusing wastewater at ULB_t (in USD/m ³)	Average cost of freshwater production including transmission and distribution at ULB_t (in USD/m ³)															
ULB #1	0.37	0.40															
ULB #2	0.27	0.20															
ULB #3	0.33	0.31															
ULB #4	0.27	0.32															

Case II: Urban Local Body

S.No.	Step	Illustrative Example
4	If at ULB_t : ii. Levelized cost of treating and reusing wastewater > the average cost for freshwater production, then the ULB level reuse target is fixed at an appropriate value between ULB_t and ULB_t' , where the levelized cost of treating and reusing freshwater is just less than the average cost of freshwater production.	<p>Case II (as in ULB #2 & ULB #3): Here, the reuse target is arrived at by undertaking scenario analysis and computing the value of percentage of wastewater reuse where the levelized cost is just less than the average cost of production.</p>



3.1 Designation of users to participate in trading scheme

3.2 Establish the baseline

3.3 Notification of reuse targets

3.4 Install hardware for real-time monitoring and data capture

3.5 Data transmission and storage

3.6 Data validation through algorithms

3.7 Issuance of WRCs

3.8 Notification of the trading process

3.9 Set Pricing Guidelines

3.10 WRCs reporting and settlements

3.11 Renotification of users

Case II: Urban Local Body

S.No.	Step	Illustrative Example																																			
5	Arrive at the overall municipality level targets by summation of the individual reuse target for each urban local body	<p>The individual and overall targets for the four participating ULBs are as follows:</p> <table border="1"> <thead> <tr> <th>ULB unit</th> <th>Baseline reuse</th> <th>Theoretical reuse</th> <th>Target reuse</th> <th>Absolute Target reuse (in MLD)</th> </tr> </thead> <tbody> <tr> <td>ULB #1</td> <td>14%</td> <td>65%</td> <td>65%</td> <td>416</td> </tr> <tr> <td>ULB #2</td> <td>5%</td> <td>50%</td> <td>25%</td> <td>22.5</td> </tr> <tr> <td>ULB #3</td> <td>10%</td> <td>40%</td> <td>35%</td> <td>50.4</td> </tr> <tr> <td>ULB #4</td> <td>8%</td> <td>60%</td> <td>60%</td> <td>47.4</td> </tr> <tr> <td colspan="4">Overall Municipal sector reuse target</td> <td>536.3</td> </tr> <tr> <td colspan="4">Overall municipal sector reuse target in %</td> <td>56%</td> </tr> </tbody> </table> <p>For instance, ULB 3 has a theoretical reuse target of 40%. To achieve this reuse target, its levelized cost of recycled wastewater is greater than the cost of production of water. So, this target is not economically viable for ULB 3. We find that at a reuse target of 35%, the levelized cost of recycled wastewater is just less than the average cost of production. Hence, the reuse target for ULB 3 is 35%.</p>	ULB unit	Baseline reuse	Theoretical reuse	Target reuse	Absolute Target reuse (in MLD)	ULB #1	14%	65%	65%	416	ULB #2	5%	50%	25%	22.5	ULB #3	10%	40%	35%	50.4	ULB #4	8%	60%	60%	47.4	Overall Municipal sector reuse target				536.3	Overall municipal sector reuse target in %				56%
ULB unit	Baseline reuse	Theoretical reuse	Target reuse	Absolute Target reuse (in MLD)																																	
ULB #1	14%	65%	65%	416																																	
ULB #2	5%	50%	25%	22.5																																	
ULB #3	10%	40%	35%	50.4																																	
ULB #4	8%	60%	60%	47.4																																	
Overall Municipal sector reuse target				536.3																																	
Overall municipal sector reuse target in %				56%																																	

On establishing reuse targets for individual Designated Water Users, the Implementation Agency will notify the respective user of the targets and will announce the commencement of the target year. These

reuse targets will be announced through the WRCNet Portal.



Disclosure of reuse targets via the WRCNet Portal

The Implementation Agency, on computing the reuse targets, shall notify the respective Designated Water Users through the WRCNet Portal. The reuse targets are filled up in a form on the WRCNet Portal by the authorized staff of the Implementation Agency. Details of the reuse targets are sent to the

respective water user along with proper notification so that the user can request changes via the portal, which, if approved by the competent authority, get saved in the WRCNet Portal database. The swim-lane process diagram for the materialization of the use case – setting of the reuse targets is provided in Figure 22.

Figure 22: Swim-lane process diagram for setting reuse targets

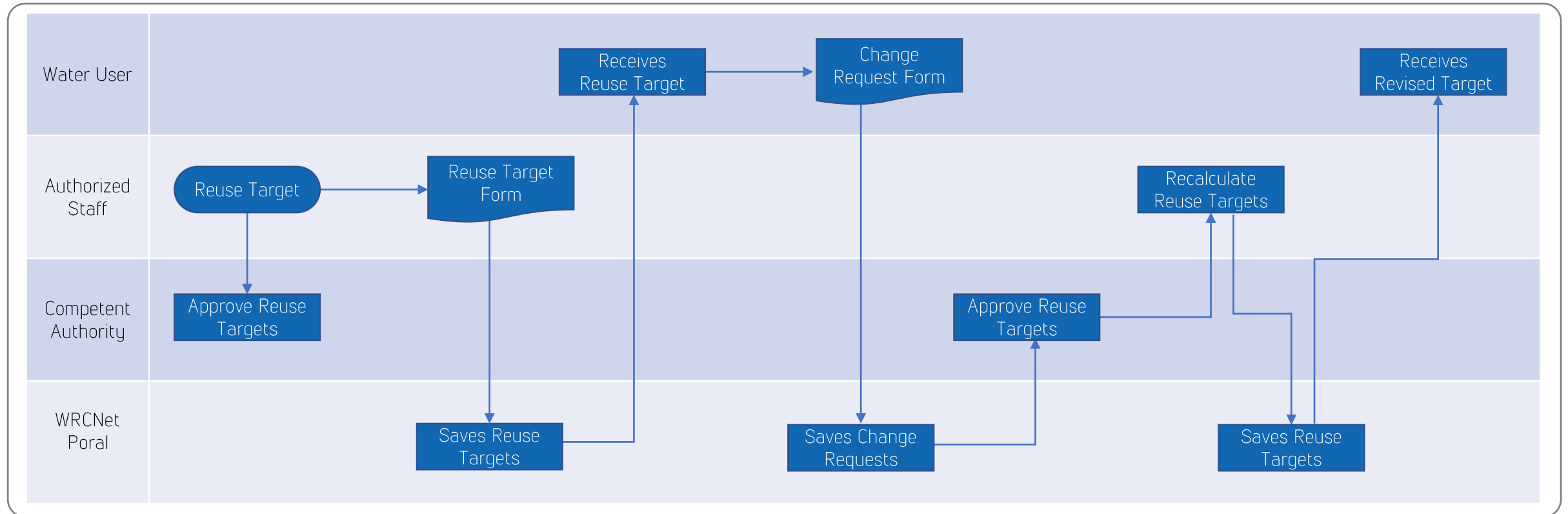

The indicative data structures for saving the reuse targets in the database are elaborated in Figure 23. Targets are stored in the database for reference and any change in the reuse targets are captured through the audit trail.

Figure 23: Indicative data structures for persisting reuse targets of water

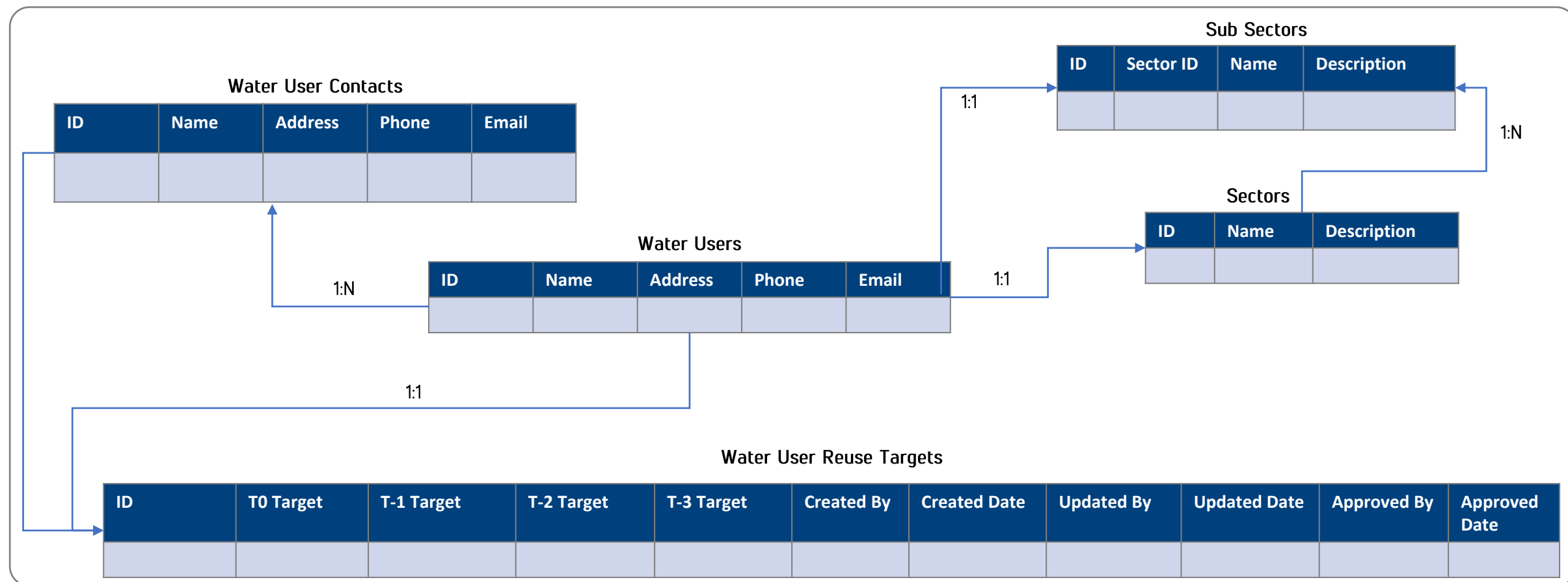

3.1 Designation of users to participate in trading scheme	3.2 Establish the baseline	3.3 Notification of reuse targets	3.4 Install hardware for real-time monitoring and data capture	3.5 Data transmission and storage	3.6 Data validation through algorithms	3.7 Issuance of WRCs	3.8 Notification of the trading process	3.9 Set Pricing Guidelines	3.10 WRCs reporting and settlements	3.11 Renotification of users
---	----------------------------	-----------------------------------	--	-----------------------------------	--	----------------------	---	----------------------------	-------------------------------------	------------------------------

The interactions of the WRCNet Portal’s user with the WRCNet Portal solution are depicted in Figure 24.

Figure 24: Interaction between WRCNet Portal user and WRCNet Portal solution

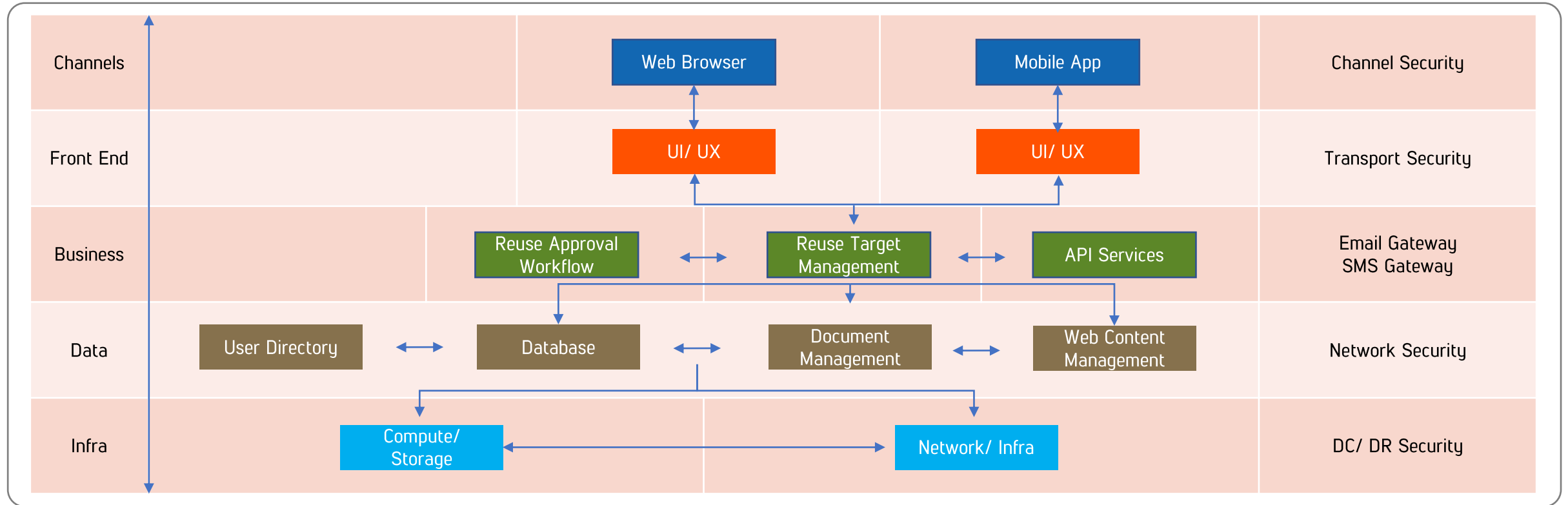

As indicated in Figure 24, there shall be two channels of interaction – browser and mobile app, with the help of which the reuse target forms are filled, viewed, changed (if required), approved and retained in the WRCNet Portal database. The business logic for the use case of setting up of reuse targets will be handled by the business modules – reuse approval workflow management and reuse target management.

3.1 Designation of users to participate in trading scheme	3.2 Establish the baseline	3.3 Notification of reuse targets	3.4 Install hardware for real-time monitoring and data capture	3.5 Data transmission and storage	3.6 Data validation through algorithms	3.7 Issuance of WRCs	3.8 Notification of the trading process	3.9 Set Pricing Guidelines	3.10 WRCs reporting and settlements	3.11 Renotification of users
---	----------------------------	-----------------------------------	--	-----------------------------------	--	----------------------	---	----------------------------	-------------------------------------	------------------------------

3.4 Install hardware for real-time monitoring and data capture

The performance of the Designated Water Users over the WRC trading cycle will be monitored and assessed for the integrity of the system. This performance assessment will be based on the hardware/ sensors installed at the premises of the respective Designated Water User.

Data requirements for performance assessment

We discuss three applicable use cases: a) industrial plant/ park, b) industrial process, and c) domestic sewage, including the respective sensor or hardware meter mount points. The sensor or hardware meter mount points across these use cases are indicated in Figure 25.

Figure 25: Sensor or hardware meter mount points across use cases

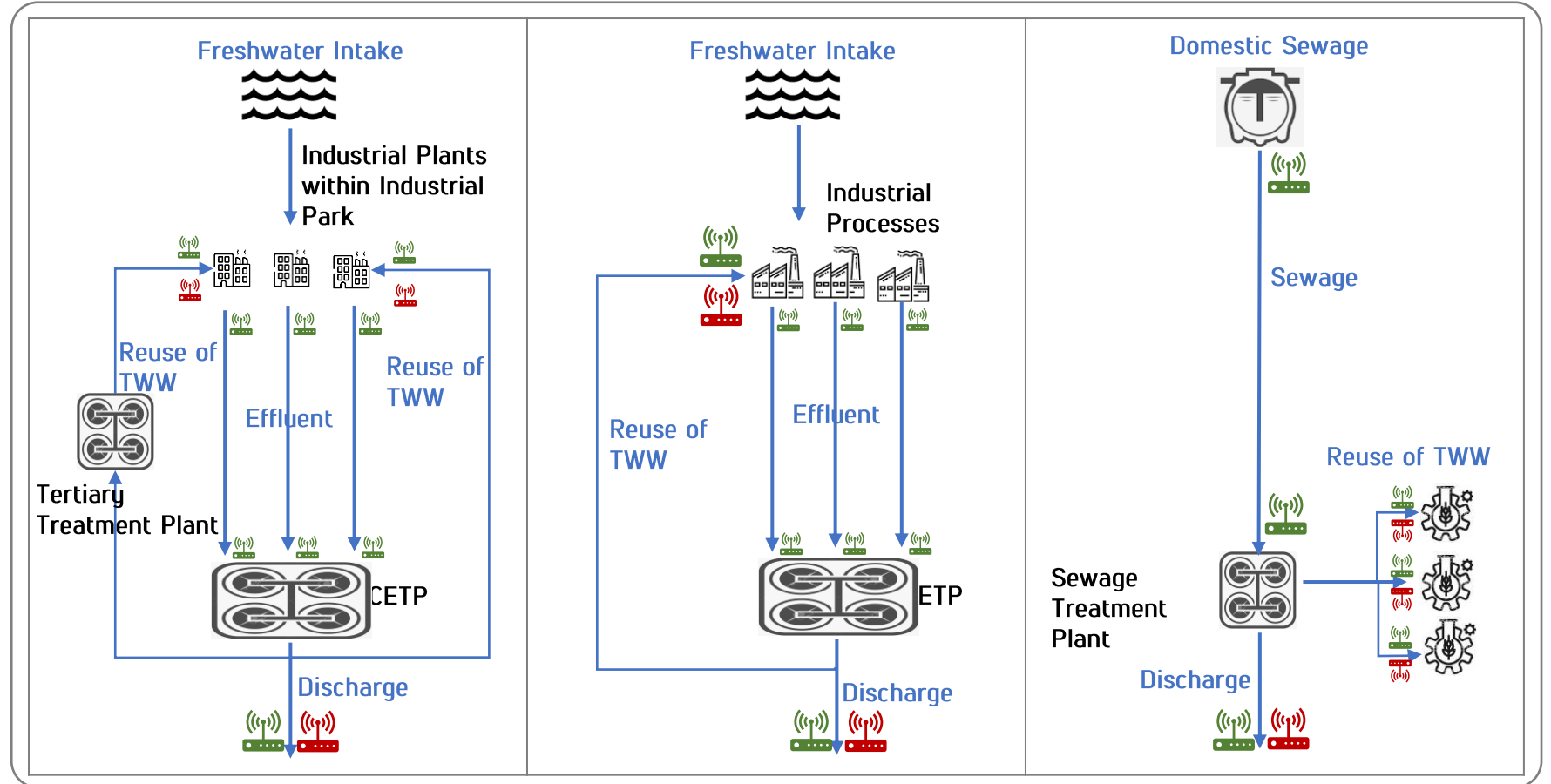

3.1 Designation of users to participate in trading scheme	3.2 Establish the baseline	3.3 Notification of reuse targets	3.4 Install hardware for real-time monitoring and data capture	3.5 Data transmission and storage	3.6 Data validation through algorithms	3.7 Issuance of WRCs	3.8 Notification of the trading process	3.9 Set Pricing Guidelines	3.10 WRCs reporting and settlements	3.11 Renotification of users
---	----------------------------	-----------------------------------	--	-----------------------------------	--	----------------------	---	----------------------------	-------------------------------------	------------------------------

These sensors are mounted to monitor the performance of the respective users, and the locations are indicated in Table 11.

Table 11: Location of sensors across use cases

Location	Flow Sensor	Quality Sensor (pH, BOD, COD, TSS)
Case I (a): Industrial Park, with multiple industrial plants and a CETP		
Outlet of each industrial plant	✓	
Inlet of CETP	✓	
Inlet of each industrial plant for treated wastewater	✓	✓
Point of discharge of treated wastewater from CETP to environment	✓	✓
Case I (b): Industrial Plant, with an ETP		
Outlet of industrial plant, for each industrial process	✓	
Inlet of ETP	✓	
Inlet of industrial plant for treated wastewater	✓	✓
Point of discharge of treated wastewater from ETP to environment	✓	✓
Case II: Urban Local Bodies		
Outlet of sewage generating activities	✓	
Inlet of WWTP	✓	
Inlet of each user of treated wastewater	✓	✓
Point of discharge of treated wastewater from STP to environment	✓	✓

With the increasing awareness of maturity of the technological solutions, environmental regulators are developing guidelines for efficient online monitoring, as elaborated in Annexure 8. In line with the local regulations and guidelines, users may install hardware based on the indicative specifications for sensors measuring flow volumetrics, pH content, turbidity and BOD, COD and TSS, as elaborated in Table 12. The actual sensor specifications for the implementation may vary depending upon the local context and constraints.



3.1 Designation of users to participate in trading scheme	3.2 Establish the baseline	3.3 Notification of reuse targets	3.4 Install hardware for real-time monitoring and data capture	3.5 Data transmission and storage	3.6 Data validation through algorithms	3.7 Issuance of WRCs	3.8 Notification of the trading process	3.9 Set Pricing Guidelines	3.10 WRCs reporting and settlements	3.11 Renotification of users
---	----------------------------	-----------------------------------	--	-----------------------------------	--	----------------------	---	----------------------------	-------------------------------------	------------------------------

Table 12: Illustrative specifications for sensors

S.No.	Measure	Sensor	Parameters	Protocol	Specification	Use Case
1	Volumetric	Clamp Type Flowmeter	Meter Cube per Hour, Flow in Meter per second	RS485, SCADA, MODBUS	<ul style="list-style-type: none"> Clamping type 80-100mm Diameter + 1% Accuracy Instantaneous and Totalizer < 32 m/s Optional LCD display 	<ul style="list-style-type: none"> Online Volumetric flow measurement Volume totalizer
2	pH content	Online pH Sensor	PH in 4-20mA, Time Stamp	RS232	<ul style="list-style-type: none"> pH Range: 0-14 Res: pH-0.01 ORP-1Mv Temperature Compensation High/Low process alarm Semi-auto calibration LCD display 	<ul style="list-style-type: none"> To have accurate alum content balance during filtration To ensure neutral for drinking supply
3	Turbidity	Online Turbidity Analyzer	NTU of Water	RS485, SCADA, MODBUS	<ul style="list-style-type: none"> 0.01-4000 NTU for River Water 0.01-200 NTU for Drinking Water Res: 0.1 NTU Pressure: <0.4Mpa Flow: <2.5m/s Titanium alloy probe (Sea Water grade) 	<ul style="list-style-type: none"> Measurement of Turbidity at both input raw water and filtered drinking water. To determine quality and proportion of chemical adding
4	BOD/COD/TSS	Spectrometry BOD Sensor		MODBUS RTU Gateway	<ul style="list-style-type: none"> accuracy standard solution (>1 mg/l) NO3-N: +/- 2% +1/OPL[mg/l] COD-KHP: +/-2% +10/OPL[mg/l] <p>Note: OPL: optical pathlength in mm</p>	<ul style="list-style-type: none"> Drinking Water BOD Measurement ETP Bod Measurement



3.5 Data transmission and storage

It is important that real-time data is collected and stored securely by ensuring that transmitted data is not compromised through data tampering and

hacking of sensors is also critical. This is elaborated in Exhibit 4

Exhibit 4: New frontiers in data management

Key issues with data capture management and analytics: Data may be compromised before transmission in instances like capturing emission data from chimneystacks. Similar issues are possible in case of data transmission from IoT devices for monitoring water flow and water quality. For instance: physical removal of device, immersion in wrong samples, data manipulation before upload to servers may compromise the quality of data and have negative implications of the sanctity of WRC trading.

Recent avenues in data management: Some technological measures that may be undertaken to ensure transparent and real-time data transmission and storage include:

- Machine Learning (ML) and AI (Artificial intelligence) algorithms may be used to detect any anomalies through detection of deviations.
- Video analytics may be explored for real-time monitoring of IoT devices. It allows for capture of only those instances when any form of movement around the devices is monitored. In this manner, anomalies may be detected by capturing time stamp of the images just prior and post the incident. Video analytics helps limit constant monitoring and storage of large chunks of video.
- The data transmitted from the sensor should be encrypted and only decrypted on the cloud server to prevent hacking.
- The sign offs can be captured on a block chain environment to enhance security and transparency.
- A tamper resistant enclosure may be provided for protection of device.

Modalities of data transmission

The installed meters and sensors shall record and periodically send data from the hardware meters to a central data warehouse. The hardware or sensors shall need to be configured to send the live real-real time to the gateway or IOT hub published by the WRCNet Portal. There may be an edge server located at the site of the water user for any online filtering or aggregation of data points and then re-transmit to the WRCNet Portal's published endpoint.

Receipt of the transmitted data

The IOT Hub of the WRCNet Portal shall be required to receive the transmitted data from the hardware meters or sensors and execute any unmarshalling of the protocol wrappers or format translations to convert into canonical form. This may include encryption/ decryption and URL-based data transfers, allowing for a change in the IP configurations, if required. The WRCNet Portal shall deploy rule-based filtering of the received data by any stream filter technology (Kafka clusters as an example) to report any exception or deviation from the acceptable range to the MIS dashboard.

Modalities of data storage

Keeping in view the quantum of data that is to be stored and the frequency of data storage, the data repository of the WRCNet Portal shall preferably be a data lake for a huge volume of hardware-transmitted real time data, optimized for a high order of writes and low order of reads. The data lake shall be designed from the start to service multiple petabytes of information while sustaining hundreds of gigabits of throughput. The data lake storage shall allow to manage and access data just as one would with a Hadoop Distributed File System (HDFS).

The security model for data lake shall minimally support the ACL and POSIX permissions. Settings may be configured through frameworks like Hive and Spark. The data lake shall offer low-cost storage capacity and transactions. The drivers shall be specifically optimized for big data analytics. The corresponding REST APIs shall need to be surfaced through the endpoint API (s).

Encryption protocols shall need to be defined for data capture and transmission, to ensure that the data is tamper-proof, like Secure Sockets Layer (SSL).

3.1 Designation of users to participate in trading scheme	3.2 Establish the baseline	3.3 Notification of reuse targets	3.4 Install hardware for real-time monitoring and data capture	3.5 Data transmission and storage	3.6 Data validation through algorithms	3.7 Issuance of WRCs	3.8 Notification of the trading process	3.9 Set Pricing Guidelines	3.10 WRCs reporting and settlements	3.11 Renotification of users
---	----------------------------	-----------------------------------	--	-----------------------------------	--	----------------------	---	----------------------------	-------------------------------------	------------------------------

The schematic diagram in Figure 26 illustrates the movement of the data from hardware meters or sensors to the IOT Hub of the WRCNet Portal and from IOT Hub to data lake via Stream Filters. Data from the data lake shall need to be consumed by the Trading Platform for execution of WRC trades and for MIS, Dashboard and Analytics.

Figure 26: Movement of data from meters/ sensors

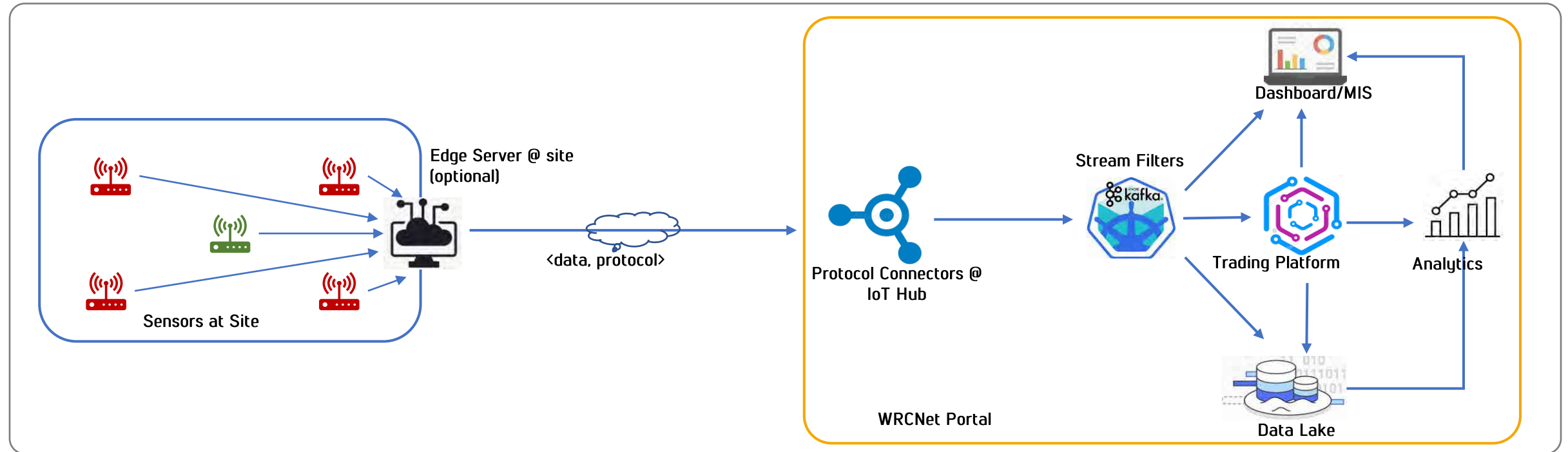

3.1 Designation of users to participate in trading scheme	3.2 Establish the baseline	3.3 Notification of reuse targets	3.4 Install hardware for real-time monitoring and data capture	3.5 Data transmission and storage	3.6 Data validation through algorithms	3.7 Issuance of WRCs	3.8 Notification of the trading process	3.9 Set Pricing Guidelines	3.10 WRCs reporting and settlements	3.11 Renotification of users
---	----------------------------	-----------------------------------	--	-----------------------------------	--	----------------------	---	----------------------------	-------------------------------------	------------------------------

The schematic diagram in Figure 27 illustrates the indicative design of the solution. The data from the hardware meters or sensors shall flow into the data lake via IoT connectors.

Figure 27: Indicative solution for data movement

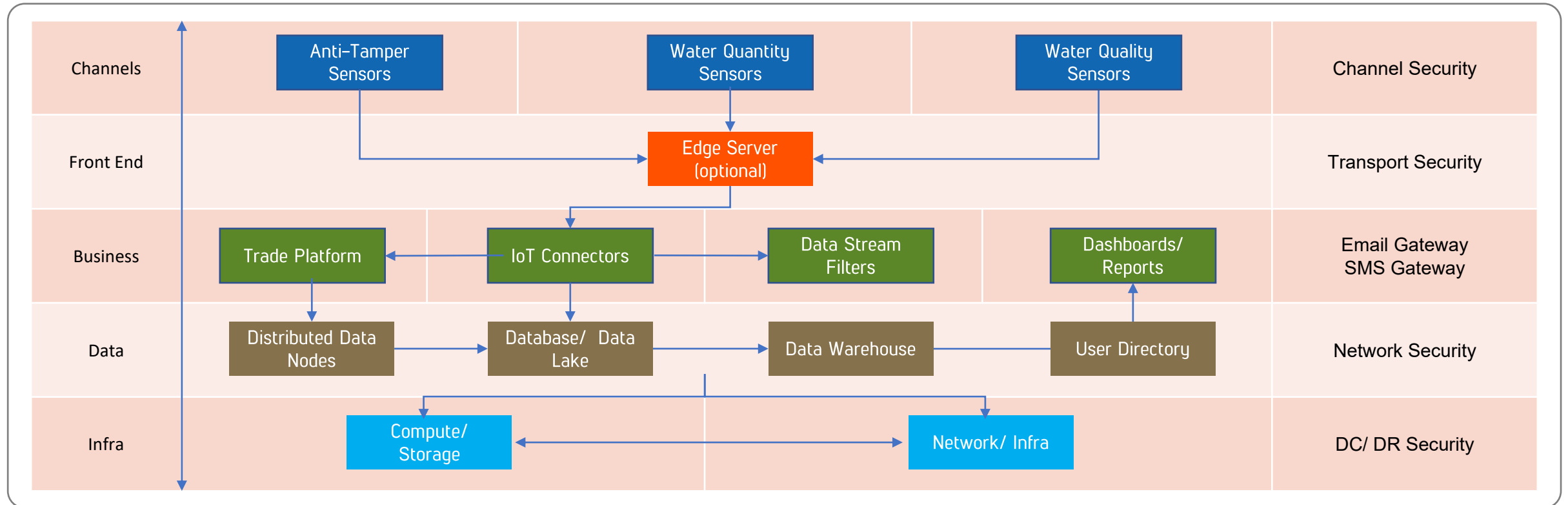



3.1 Designation of users to participate in trading scheme

3.2 Establish the baseline

3.3 Notification of reuse targets

3.4 Install hardware for real-time monitoring and data capture

3.6 Data validation through algorithms

3.7 Issuance of WRCs

3.8 Notification of the trading process

3.9 Set Pricing Guidelines

3.10 WRCs reporting and settlements

3.11 Renotification of users

3.6 Data validation through algorithms

With real-time monitoring and storage of data, the technology interface will check for anomalous readings. These anomalous readings could be either due to meter malfunction or issues with the treatment plant and shall require immediate redressal. Accordingly, identified rules of thumb¹⁸ of specific water consumption and specific wastewater generation, among others, and historical meter readings shall be utilized to

identify anomalous readings. The Implementation Agency shall develop these rules of thumb based on extensive consultations, with industry stakeholders, process experts and academicians.

These rules/ algorithms shall be configured in the rule-base of the WRCNet portal and, over time, as more data is monitored and stored, Artificial Intelligence/ Machine Learning algorithms can be

developed. Based on data mining, ML and statistical analysis techniques, historical patterns shall be assessed to predict current gap in micro levels and other parameters in a macro analysis. The data validation application and its algorithms are expected to evolve over time. Any anomalies identified to be flagged for manual intervention and further action.

Deploying predictive AI/ ML algorithms shall enable early detection of faults, including abnormal reporting. Some illustrative algorithms are defined in Table 13. Any deviations observed are flagged and may be clarified by the respective user, including a change in production process or adoption of water efficiency measures.

Table 13: Data validation through algorithms

Predictive Analytics	AI/ ML Algorithm	Indicative Visualization	Illustrative example of data validation technique
<p>Parameter Trending/ Forecasting.</p> <p>Here, each parameter shall be forecasted by referring to its values in the past or historical data.</p> <p>Decisions shall be made based on highs and lows of the parameters and the required remedial interventions.</p>	<ul style="list-style-type: none"> a. ARIMA (Autoregressive Integrated moving Averages) b. SARIMA (Seasonal Autoregressive Integrated Moving Average), for seasonal comparison c. Exponential Smoothing <p>Above algorithms may be used for volume of discharge and related parameters. Ordinary Least Squares method</p> <ul style="list-style-type: none"> d. Ordinary Least Squares method e. Logistics Regression f. Random Forest g. Neural Networks 		<p>Identify relationship of water consumption and wastewater generation with capacity utilization and production processes of industrial unit. This can be used to check for anomalies due to sudden change in say capacity utilization. Such deviations may also arise due to a change in production process or adoption of water efficiency measures and can be clarified by the respective user accordingly.</p>

18. These rules of thumb will be based on historical performance of the users or, in the absence of data of the specific user, performance of users of similar kind or producing similar products.

3.1 Designation of users to participate in trading scheme	3.2 Establish the baseline	3.3 Notification of reuse targets	3.4 Install hardware for real-time monitoring and data capture	3.5 Data transmission and storage	3.6 Data validation through algorithms	3.7 Issuance of WRCs	3.8 Notification of the trading process	3.9 Set Pricing Guidelines	3.10 WRCs reporting and settlements	3.11 Renotification of users
---	----------------------------	-----------------------------------	--	-----------------------------------	--	----------------------	---	----------------------------	-------------------------------------	------------------------------

Predictive Analytics	AI/ ML Algorithm	Indicative Visualization	Illustrative example of data validation technique
<p>Exception Trending/ Forecasting</p> <p>Here the exception preparedness shall be analysed by calculating the exceptions/ extremes vis-à-vis a parameter value change.</p>	<p>a. Z-Score</p> <p>b. Isolation Forest</p> <p>These algorithms will help find the outliers and thus the exceptions in the data that could help sudden deviant or extreme variations in the data.</p>		<p>Identify anomalies in the forecasting – for instance forecasted discharge, but not observed, or under forecasted discharge or over forecasted discharge.</p>
<p>Correlation between Parameters</p> <p>Here, dependencies amongst parameters shall be analysed to help understand the cause and affect relations vis-à-vis water quality.</p>	<p>a. Correlation analysis</p> <p>b. Linear Regression</p> <p>c. Multivariate Regression</p> <p>d. Support Vector Regression (SVR)</p>		<p>Assess dependency between quantum of wastewater generated and individual production processes or production inputs.</p>

3.1 Designation of users to participate in trading scheme	3.2 Establish the baseline	3.3 Notification of reuse targets	3.4 Install hardware for real-time monitoring and data capture	3.5 Data transmission and storage	3.6 Data validation through algorithms	3.7 Issuance of WRCs	3.8 Notification of the trading process	3.9 Set Pricing Guidelines	3.10 WRCs reporting and settlements	3.11 Renotification of users
---	----------------------------	-----------------------------------	--	-----------------------------------	--	----------------------	---	----------------------------	-------------------------------------	------------------------------

Predictive Analytics	AI/ ML Algorithm	Indicative Visualization	Illustrative example of data validation technique
<p>Most significant Parameter</p> <p>This analysis will help identify the most impactful parameters so that informed decisions may be made.</p>	<ul style="list-style-type: none"> a. Step Forward feature selection b. Standardisation and r-squared comparative analysis c. Model fitment approach d. N-way ANOVA e. PCA (Principal Component Analysis) f. LDA (Linear Discriminant Analysis) 		<p>Decision making tool to identify most significant parameter with respect to water consumption or wastewater generation.</p>
<p>Composition Trending/ Forecasting</p> <p>It will help understand the current and changing nature of the water composition. Related comparative analysis will allow understanding of the ecosystem.</p>	Multivariate Regression		<p>Estimating water consumption for industrial or domestic use.</p>
<p>Pattern Clusters or Profiling</p> <p>This methodology largely helps us to know the unknown or the latent information about the water data. It is a methodology to segregate data points into clusters from which meaningful insights are inferred.</p>	<ul style="list-style-type: none"> a. Unsupervised Machine Learning b. Clustering 		<p>Used for clustering/ classification of users based on water consumption.</p>

3.1 Designation of users to participate in trading scheme	3.2 Establish the baseline	3.3 Notification of reuse targets	3.4 Install hardware for real-time monitoring and data capture	3.5 Data transmission and storage	3.6 Data validation through algorithms	3.7 Issuance of WRCs	3.8 Notification of the trading process	3.9 Set Pricing Guidelines	3.10 WRCs reporting and settlements	3.11 Renotification of users
---	----------------------------	-----------------------------------	--	-----------------------------------	--	----------------------	---	----------------------------	-------------------------------------	------------------------------

3.7 Issuance of WRCs

To achieve their respective targets, the Designated Water Users have three options:

- Invest in wastewater reuse infrastructure and recycle treated wastewater.
- Adopt water efficiency measures, hence reducing water withdrawals from the environment (and accordingly wastewater generated).
- Purchased treated wastewater, say from a water utility.

Accordingly, the performance of each Designated Water User is to be assessed, to understand

whether they have achieved, underachieved, or overachieved their target.

The monitoring and verification mechanism

An effective monitoring and verification mechanism are essential for the success of the WRC scheme. The underlying principles for a robust monitoring and verification mechanism which are somewhat like that of the baseline determination process have been elaborated in Figure 28.

In line with these principles, the monitoring and verification mechanism of the WRC scheme will include engaging the empaneled water auditors to assess the performance of the Designated Water Users in the assessment year against the respective wastewater reuse targets. The steps involved include:

- The Designated Water User will prepare a performance assessment document, based on the format defined by the Implementation Agency, summarizing the user's performance.
- The Designated Water User will engage an empaneled water auditor to verify the prepared performance assessment document. The empaneled water auditor will prepare a verification report based on a water audit and scrutiny of all the activities undertaken by the respective user, with the user providing complete data and necessary documents. The activities undertaken by the water auditor are discussed in Section 3.2
- The performance assessment document and verification report are submitted to the designated agency – the Regulator (in a regulated approach) or the Certification Entity (in a voluntary approach).

- If the performance assessment document is in line with the verification report, then WRCs are issued to the respective Designated Water User.

Check-verification of water audit report

Check-verification is an independent review and ex-post determination of the Designated Water User's performance by the designated agency – the Regulator (in a regulated approach) or the Certification Entity (in a voluntary approach). On receiving the certified audit report from the Designated Water User, the designated entity may, on its own initiative or on receipt of a complaint regarding any error or inconsistency or misrepresentation (within a defined time duration from either the date of submission of the water audit report or issuance of WRCs), initiate action for review of the verification report.

To ensure independence of the check-verification process, the designated agency engages an empaneled water auditor, ideally different from the one that did the baseline determination and from the one that performed the water audit for the user.

Figure 28: Principles for monitoring and verification mechanism

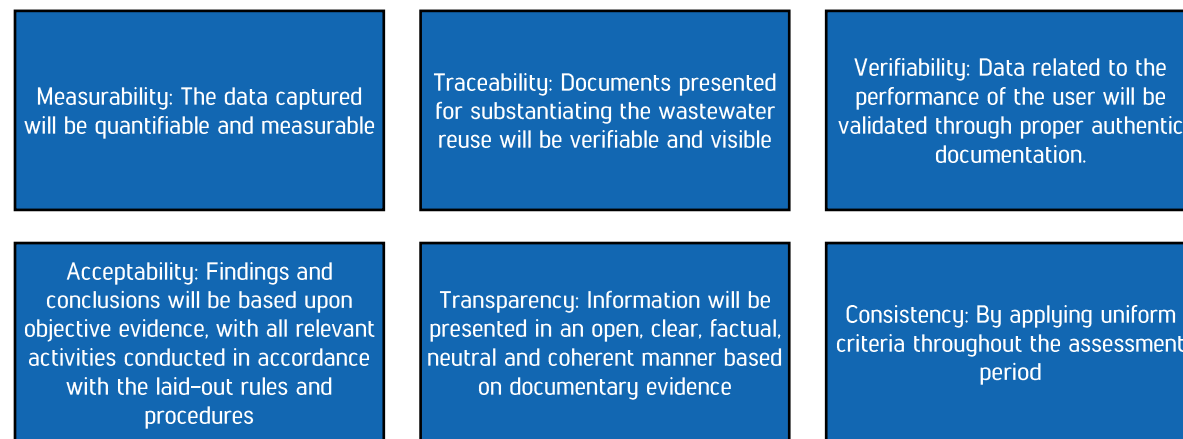



3.1 Designation of users to participate in trading scheme	3.2 Establish the baseline	3.3 Notification of reuse targets	3.4 Install hardware for real-time monitoring and data capture	3.5 Data transmission and storage	3.6 Data validation through algorithms	3.7 Issuance of WRCs	3.8 Notification of the trading process	3.9 Set Pricing Guidelines	3.10 WRCs reporting and settlements	3.11 Renotification of users
---	----------------------------	-----------------------------------	--	-----------------------------------	--	----------------------	---	----------------------------	-------------------------------------	------------------------------

The check-verification process will include the following activities:

- Review of documents and on-site assessment conducted to verify the activities undertaken by the Designated Water User to comply with the wastewater reuse norms.
- Review of quantitative and qualitative information on relevant parameters
- Review of previous verification report

As part of the check-verification report, the identified auditor will include the following:

- Summary of the check-verification process, the results of the assessment and the auditor's opinion along with the supporting documents, and
- Details of check-verification activities carried out to arrive at the opinion and conclusion, including the details captured during the process and conclusion relating to compliance with wastewater reuse norms, with reference to the baseline specific water withdrawal and baseline wastewater reuse.

If the check-verification report raises concerns and comments on the earlier submitted verification report, the check-verification auditor will calculate the effect of such opinion on:

- Compliance with the wastewater reuse norms.
- Issue or purchase of WRCs.
- Liability of the earlier empaneled water auditor in giving the verification report, and
- Unfair gain by the respective designated water user.

In case of unfair gain, the Implementation Agency shall impose a penalty on the respective Designated Water User, based on pre-defined rules and procedures. The penalty shall also include the cost incurred for carrying out the check-verification. Further, in case the check-verification has been initiated based on a complaint obtained by the designated agency and if there are no inconsistencies observed, then the cost of the check-verification will be borne by the respective complainant.

Calculating the number of WRCs

As discussed earlier, the user performance will be assessed based on the monitored and stored data, the data validation algorithms, and the verification, and check-verification reports. Based on the quality and quantity of treated wastewater reused by the user vis-à-vis the set target, the designated agency shall issue WRCs.

Accordingly, the WRCs are issued based on the following formula:

$$\frac{\{A - \% Reuse Target\} * Baseline wastewater generated}{Volume equivalent of 1 WRC} * Q$$

Where

- A is the wastewater reused in the assessment year, i.e., quantum of wastewater reused, divided by the quantum of wastewater generated in the assessment year.
- Baseline wastewater generated is the quantum of wastewater generated (in m³) in the baseline

year.

- Volume equivalent of 1 WRC is 1000 m³
- Q is the Quality factor based on the quality of reclaimed factor, as per Table 14

As per the algorithm in Table 14, the three level of WRCs that will be issued are Platinum, Gold and Silver.

Table 14: Algorithm for issuance of WRCs

Quantum of reclaimed wastewater	Quality of reclaimed wastewater	Level	Number of WRCs issued
1000 m ³	Grade A	Platinum	2
1000 m ³	Grade B	Gold	1.5
1000 m ³	Grade C	Silver	1

This issuance of WRCs has been explained with an illustrative example in Annexure 9.



3.1 Designation of users to participate in trading scheme	3.2 Establish the baseline	3.3 Notification of reuse targets	3.4 Install hardware for real-time monitoring and data capture	3.5 Data transmission and storage	3.6 Data validation through algorithms	3.7 Issuance of WRCs	3.8 Notification of the trading process	3.9 Set Pricing Guidelines	3.10 WRCs reporting and settlements	3.11 Renotification of users
---	----------------------------	-----------------------------------	--	-----------------------------------	--	----------------------	---	----------------------------	-------------------------------------	------------------------------

All WRCs issued to the water users shall be issued by the respective designated agency via electronic form and will be maintained on the WRCNet Portal. Moreover, the Administrator shall collate the number of WRCs against each user and share with the relevant stakeholders. The swim-lane process diagram for the issuance of WRCs is provided in Figure 29.

Figure 29: Swim-lane process diagram for issuance of WRCs

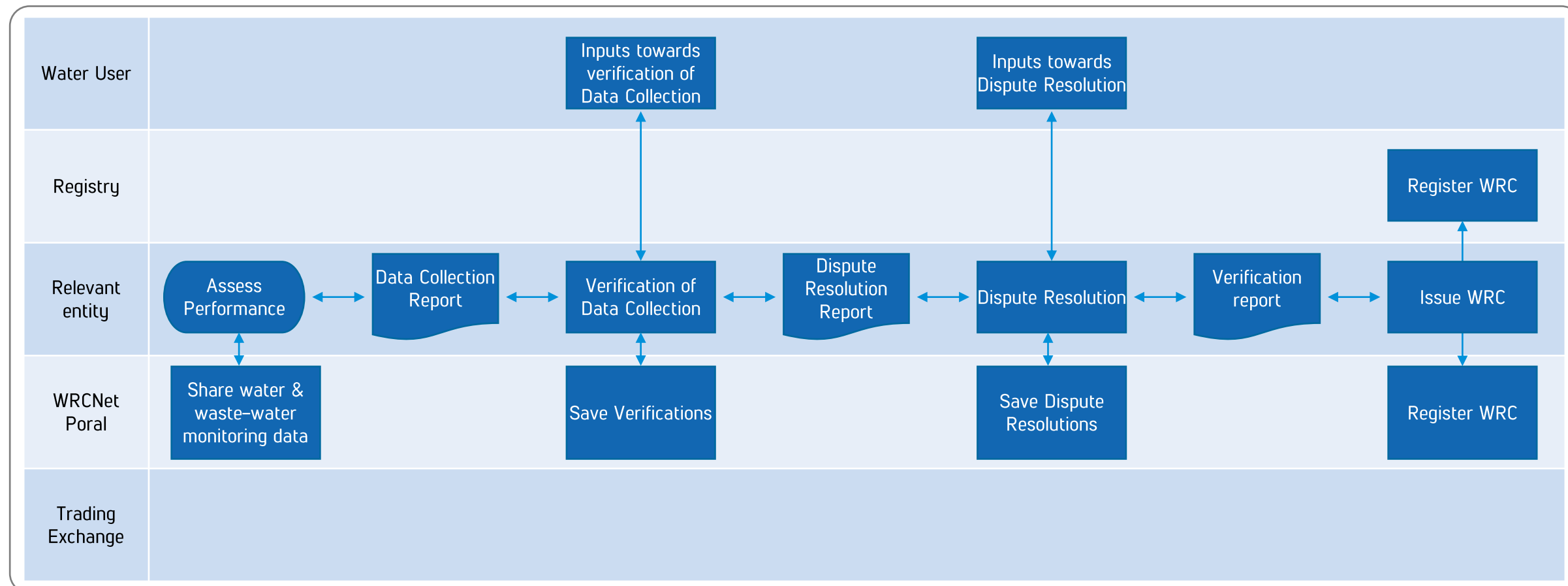

3.1 Designation of users to participate in trading scheme	3.2 Establish the baseline	3.3 Notification of reuse targets	3.4 Install hardware for real-time monitoring and data capture	3.5 Data transmission and storage	3.6 Data validation through algorithms	3.7 Issuance of WRCs	3.8 Notification of the trading process	3.9 Set Pricing Guidelines	3.10 WRCs reporting and settlements	3.11 Renotification of users
---	----------------------------	-----------------------------------	--	-----------------------------------	--	----------------------	---	----------------------------	-------------------------------------	------------------------------

3.8 Notification of the trading process

Process flow for WRCs trading

The process flow for WRC trading includes the following steps:

- i. The Registry shall provide the Trading Exchange with the list of Designated Water Users (across all sectors and industries) participating in the trading cycle. Also, the Registry, in consultation with the Trading Exchange, shall pre-define a specific time window, repeating at regular intervals, for trading of WRCs.
- ii. During the trading window, the Designated Water Users shall submit bids for buying or selling WRCs on the Trading Exchange.
- iii. The Trading Exchange shall collate bids and share with the Registry via the WRCNet Portal.
- iv. The Registry shall subsequently verify whether each water user has sufficient WRCs available for the respective transaction. Accordingly, the Registry shall submit a verification report to the Trading Exchange.
- v. On receiving a positive confirmation, the Trading Exchange shall process trading for that specific trading session. The trading will be based on double-sided auction, as defined in Section 3.9 and 3.10.
- vi. The Trading Exchange shall upload the trading confirmation report on the WRCNet Portal, and the Registry shall accordingly update the number of WRCs for each Designated Water User.

The schematic in Figure 30 captures the end-to-end flow of the process intended for WRC trading.

Figure 30: Schematic for trading of WRCs

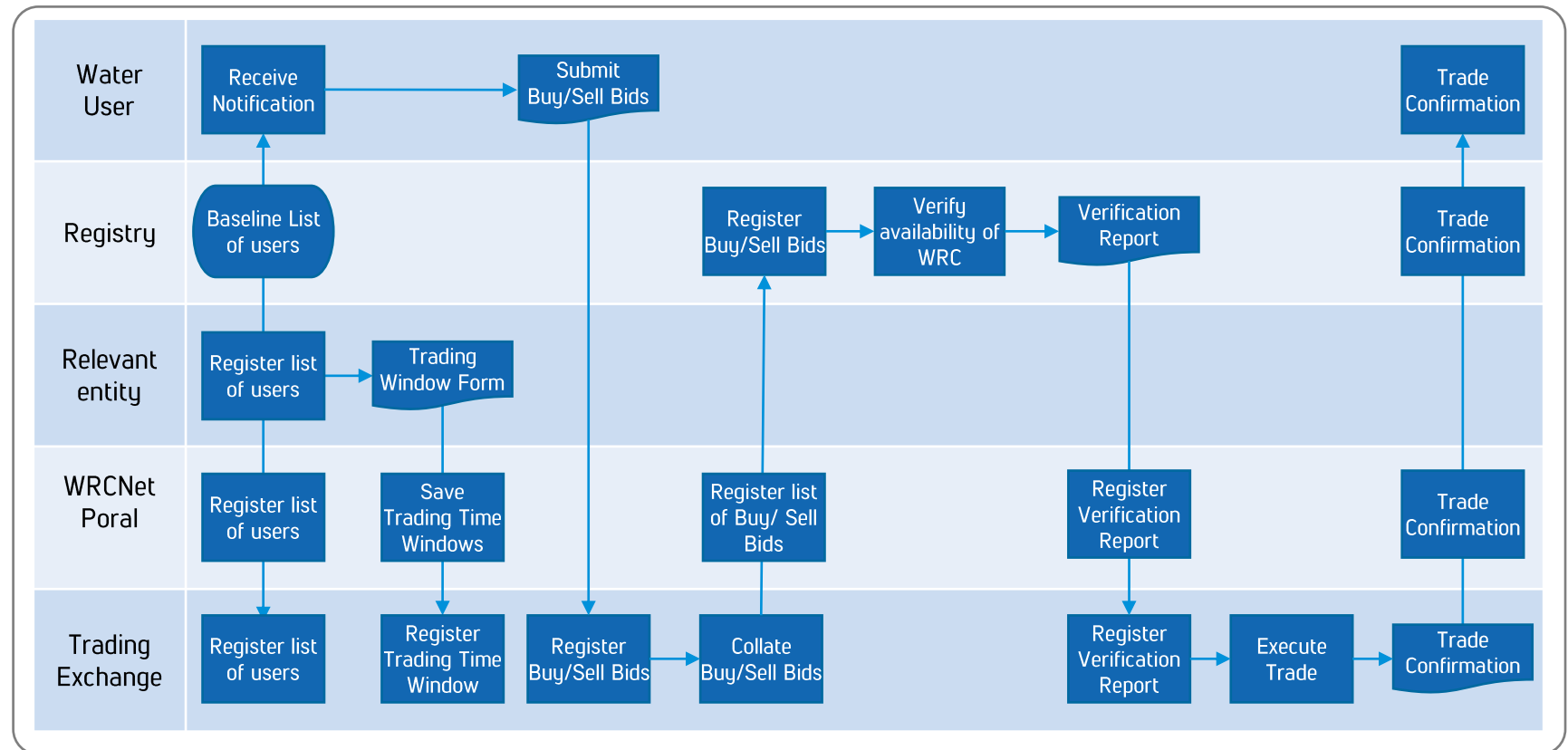

3.1 Designation of users to participate in trading scheme	3.2 Establish the baseline	3.3 Notification of reuse targets	3.4 Install hardware for real-time monitoring and data capture	3.5 Data transmission and storage	3.6 Data validation through algorithms	3.7 Issuance of WRCs	3.8 Notification of the trading process	3.9 Set Pricing Guidelines	3.10 WRCs reporting and settlements	3.11 Renotification of users
---	----------------------------	-----------------------------------	--	-----------------------------------	--	----------------------	---	----------------------------	-------------------------------------	------------------------------

Figure 31: Indicative design of the WRCs trading

The Trading Exchange shall have the following features:

- i. Message driven: Data communication is message driven i.e., participants send and receive messages.
- ii. Low end-to-end latency: A message that is sent by one participant, with several cryptographic steps, will reach the other participants with extremely low latency.
- iii. Security: All network communication between the participants in the Trading Exchange is encrypted and authenticated.
- iv. Ease of maintenance: All the benefits of an established software development language shall be used for the ease of maintenance.
- v. User roles: Trading Exchange may require separate user roles with different access rights.
- vi. Various operating options: These are important to be recognized so that the entire technology stack can run on premise or across several cloud infrastructures to avoid vendor lock-in.

An indicative design of the Trading Exchange is schematized in Figure 31.

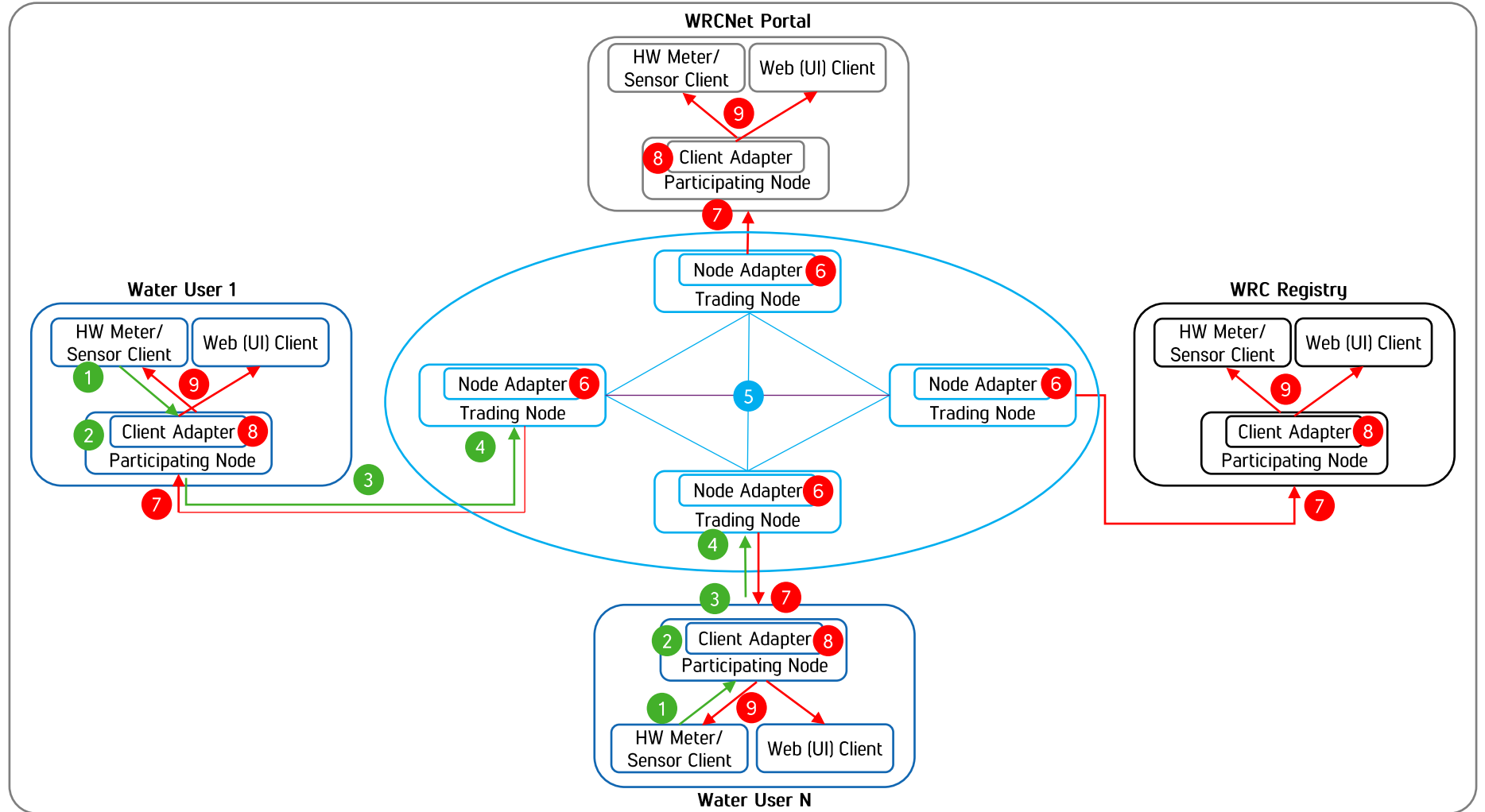

3.1 Designation of users to participate in trading scheme

3.2 Establish the baseline

3.3 Notification of reuse targets

3.4 Install hardware for real-time monitoring and data capture

3.5 Data transmission and storage

3.6 Data validation through algorithms

3.7 Issuance of WRCs

3.8 Notification of the trading process

3.9 Set Pricing Guidelines

3.10 WRCs reporting and settlements

3.11 Renotification of users

Accordingly, the following four components are depicted in Figure 31.

- i. Participating Node: Application software for distributed trading.
- ii. Client Adapter: Horizontal logic that accesses a Node Adapter and resides within a participant.
- iii. Trading Node: Executes the core trading logic.
- iv. Node Adapter: Horizontal layer that is application agnostic and adds functions to the node.

The following steps may be performed in the indicative architecture of the Trading Exchange for information exchange across the trading interfaces:

- i. The Water User Application (hardware meter or sensor) sends a message to the Client Adapter.
- ii. The Client Adapter receives and forwards a message to the Node Adapter. To do so, the Client Adapter must have established an authenticated and encrypted connection to the Node Adapter.
- iii. The Node Adapter now receives the message from the Client Adapter and forwards the message to the Trading node.
- iv. At this level, the message is pushed across other Trading Nodes.

- v. The Node Adapter receives the transactional messages.
- vi. The messages are forwarded by the Node Adapter to each Client Adapter that is connected to a Node Adapter.
- vii. The Client Adapter receives the messages and, depending on the type of the messages, application-level processing is performed on the messages.
- viii. If the default behaviour is not changed by application specific Client Adapters, the message is sent to all connected Clients/Client Applications.

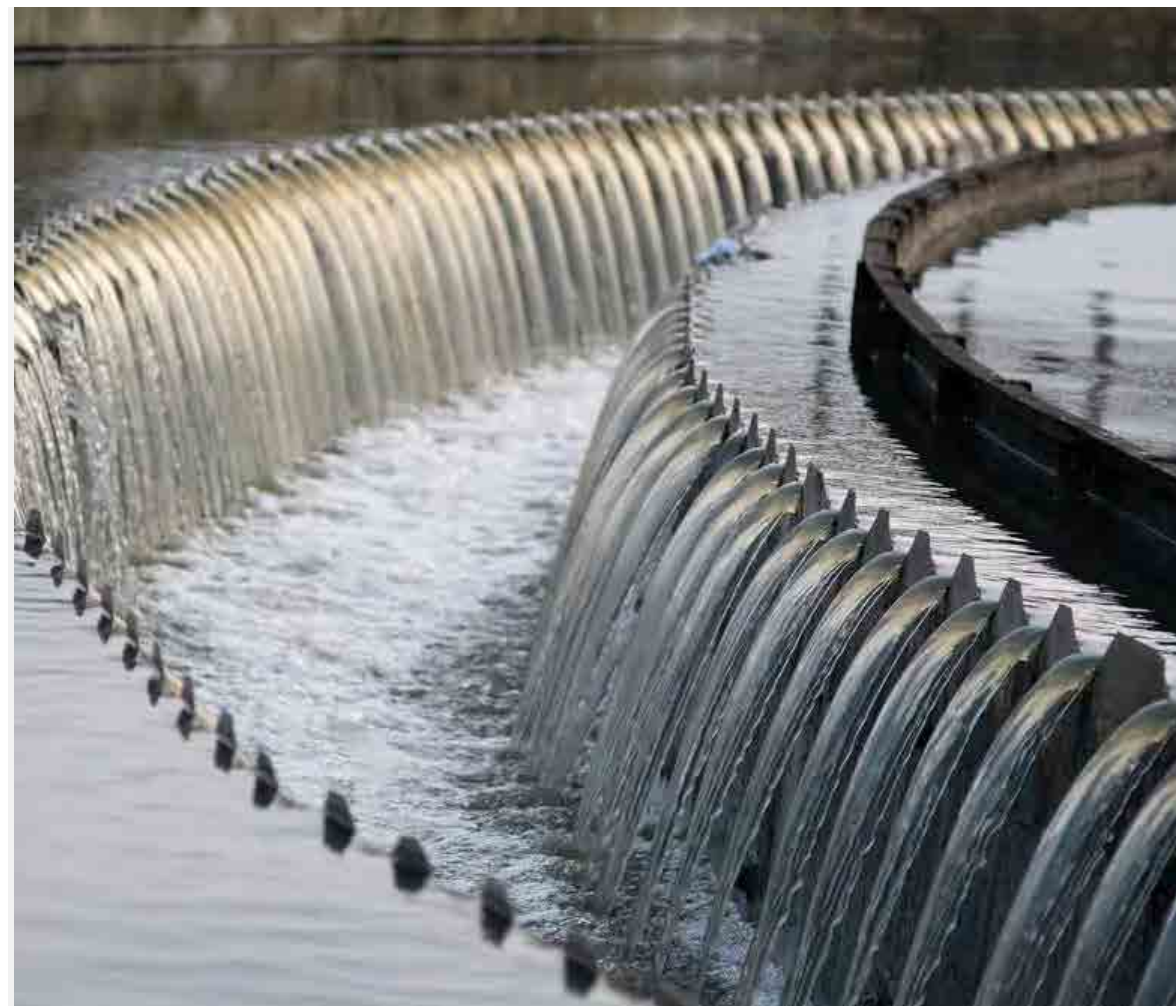

3.9 Set Pricing Guidelines

Price determination

The price of WRCs shall be market driven, based on the willingness of the sellers and buyers to transact on WRCs in the market. Accordingly, the price is based on the demand and supply, and is arrived via double-sided auction, with respective water users placing buy or sell bids at the Trading Exchange. The trading shall be based on principle of uniform pricing, with the same price offered to all users on the market, thereby ensuring transparency and ease of administration.

Also, to avoid fluctuations in the price of WRCs during a trading cycle, the prices shall be bound within a floor price and ceiling price, as determined by the Implementation Agency. This shall prevent the price of WRCs from rising and falling beyond the determined levels.

Double-sided auction

Multiple buyers and sellers are involved in the market, and any buyer/ seller may submit an offer that is observed simultaneously by all Designated Water Users during the respective trading session. While the buyers compete to make the highest bid, the sellers call out to make the lowest offer. In case a buyer's bid is acceptable to some seller, or a seller's offer is acceptable to any buyer, a trade is executed between them.

This real-time trading mechanism is popular due to its operational simplicity, efficiency, and capacity to respond quickly to dynamic market conditions. This process may be one-shot or repeated, with auction having multiple trading periods in the latter.

For instance, consider the aggregate demand-supply curve for a WRC market as illustrated in Figure 32. The intersection of demand and supply denotes the competitive equilibrium, indicating the Market Clearing Price (MCP) – the lowest price a seller is ready to take for a WRC and the highest price a buyer is ready to pay for it.

Figure 32: Induced supply and demand arrays in a market

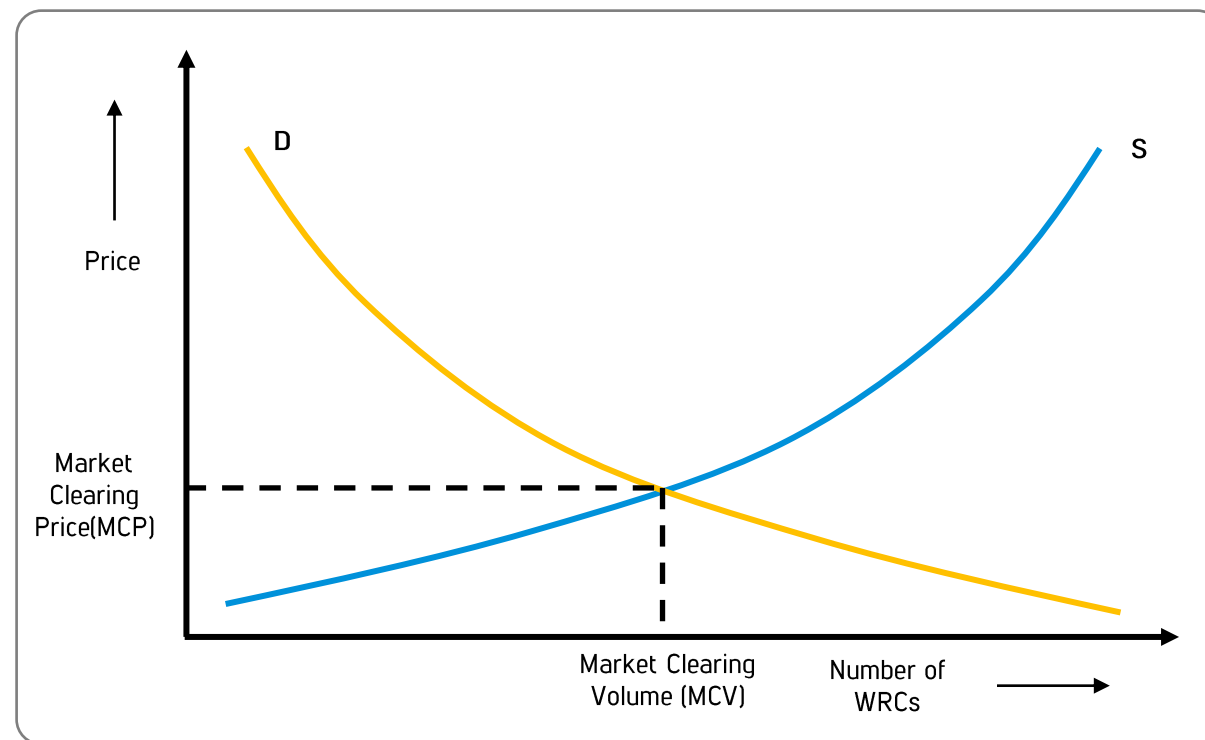

Methodology to determine the Floor and Ceiling Prices

To provide the Designated Water Users with a degree of certainty and comfort about the price of WRCs, especially during mismatch in demand-supply of WRCs, the Implementation Agency shall define and notify floor and ceiling prices, based on the prevalent technologies.

Ceiling prices represent the maximum value that may be derived by investing in recycling and reuse of treated wastewater. In times of excess demand for WRCs, the ceiling price will ensure that the price doesn't exceed the defined threshold and the buyer can make a successful transaction at reasonable prices. Similarly, floor prices represent the minimum requirements to ensure viability of wastewater treatment and ensures the seller can make a reasonable transaction in times of excess supply of WRCs. The floor and ceiling prices for a specific trading session shall be defined based on the following:

- **Levelized cost of recycled water (L) (per m³):** Net cost incurred for wastewater treatment and reuse, includes capital expenditure, O&M costs, interest on loan, interest on working capital and depreciation estimates for the defined period. The cost may vary for water users, depending on the quality of wastewater generated, the cost of the treatment process

involved, and the quality of the treated wastewater obtained.

- **Cost of water (C) (per m³):** Maximum among the tariff levied on freshwater supply or cost of unavailability of water in the region or levelized cost of supplying freshwater (i.e., cost of sourcing, storage, transmission, treatment, and distribution).

The algorithm for determination of floor and ceiling price is as follows.

Ceiling price

Ceiling price shall be calculated as the absolute difference between maximum cost of 1,000 m³ freshwater and minimum levelized cost of treating 1,000 m³ of recycled water from the list of Designated Water Users participating in the trading session¹⁹. The formula for ceiling price is:

$$\text{Ceiling Price} = \text{Max } C_i - \text{Min } L_j$$

So, the ceiling price represents the maximum value that may be derived by investing in recycling and reusing of 1,000 m³ of treated wastewater, i.e., the hypothetical case where the same plant (say i=j) incurs the least cost in treating and reusing wastewater but earns the highest revenue in lieu of freshwater savings.

Floor price

Floor price shall be calculated as the absolute difference between minimum cost of 1,000 m³ freshwater and maximum levelized cost of treating 1,000 m³ of recycled water. The formula for floor price is:

$$\text{Floor Price} = \text{Min } T_i - \text{Max } C_j$$

So, the floor price represents the minimum value that may be derived by investing in recycling and reusing of 1,000 m³ of treated wastewater, i.e., the hypothetical case where the same plant (say i=j) incurs the highest cost in treating and reusing water but earns the least revenue in lieu of water savings.

The trading of WRCs between Designated Water Users is conducted between the defined floor and ceiling prices. Further, the ceiling price and floor price shall be periodically estimated, reviewed, and revised by the Implementation Agency, considering the observations and evaluations of trading in previous trading cycles.

The computation of ceiling and floor prices has been discussed with an illustrative example in Annexure 10.1



19. Assumption: 1 WRC = 1000 m³ of reused wastewater. The algorithm for floor and ceiling prices shall be revised as per the definition of 1 WRC in the specific geography.

3.10 WRCs reporting and settlements

Post a trading session, the Trading Exchange will be empowered to discover a Market Clearing Price (MCP) and a Market Clearing Volume (MCV). The MCP and MCV shall be determined based on double sided closed auction with uniform pricing principle.

Initially, buy/ sell bids shall be placed on the Trading Exchange. The buy and sell bids shall be

aggregated to arrive at the cumulated buy and sell orders. This cumulated buy and sell orders shall be matched to obtain the MCP and MCV. On establishing the MCV and MCP, the Trading Exchange shall process the transaction; the financial settlement shall be made through the bank accounts of the buyers and sellers. The detailed steps involved in the settlement process are discussed in Annexure 10.2.



3.11 Renotification of users

The WRC scheme has been discussed with several stakeholders across geographies – governments, regulators, industry associations, water sector experts, among others. The concept and scheme contours have been discussed with the stakeholder ecosystem and their buy-in has been secured. There is tremendous potential for the concept and the realization of the associated benefits.

The implementation of a WRC scheme can start with a pilot. Through the pilot, the Implementation Agency will test the institutional design and build capacity for wide-scale adoption and implementation of the WRC scheme. The Implementation Agency will launch the pilot with the understanding that subsequent cycles of the WRC scheme could witness a change in the scheme contours.

On completion and evaluation of the pilot, feedback should be taken from the participants and their suggestions should be suitably incorporated. Industry/sector wide consultations should also be carried out for the baseline determination and target setting procedures. The buy-in of the

stakeholders will be crucial for the success of the scheme. When a critical mass of stakeholders is on board, the first phase of the WRC scheme can be launched. The number of users participating in successive phases of the WRC scheme should increase with wide scale acceptance of users from various sectors. This gradual and staggered implementation will allow for capacity-building of the stakeholder ecosystem and to allow for them to adjust to the new regulatory framework. 2030 Water Resources Group and its region-specific Multi-Stakeholder Platforms can play an important role in the scaling-up of the scheme over subsequent phases.

Evaluation of WRC phase

Post completion of a WRC phase, the performance of the scheme shall be assessed with the objective of strengthening the performance in subsequent phases. The modalities for increasing the market participation in future phases shall also be explored. The stages for evaluation and renotification are given in Figure 33.

3.1 Designation of users to participate in trading scheme	3.2 Establish the baseline	3.3 Notification of reuse targets	3.4 Install hardware for real-time monitoring and data capture	3.5 Data transmission and storage	3.6 Data validation through algorithms	3.7 Issuance of WRCs	3.8 Notification of the trading process	3.9 Set Pricing Guidelines	3.10 WRCs reporting and settlements	3.11 Renotification of users
---	----------------------------	-----------------------------------	--	-----------------------------------	--	----------------------	---	----------------------------	-------------------------------------	------------------------------

Figure 33: Cyclical nature of the WRC trading cycles

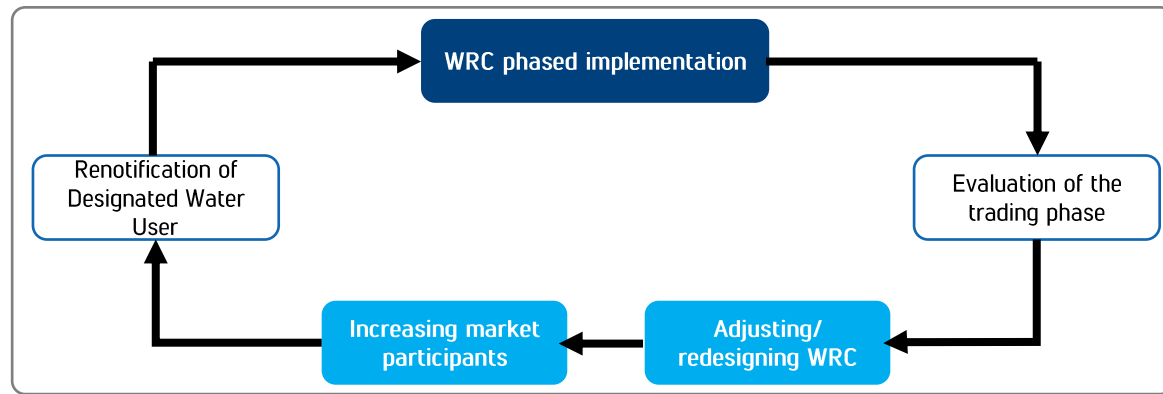

Evaluation of the WRC phase is undertaken to:

- Assess scheme effectiveness in terms of the quantum of wastewater recycled and freshwater savings achieved.
- Identify and carry forward best practices/ learnings.
- Remove/ redesign dispensable/ counterproductive measures.
- Update scheme design based on changes in external conditions, including policy development, advancement in technology, innovation, etc., and
- Ensure equitable trading

The methodology for scheme evaluation shall be based on a combination of the following:

- Economy-wide model: The actual outcome of the scheme is compared to modelled counterfactual scenario i.e., a hypothetical scenario without the actual scheme in place. such as computable general equilibrium models) try to create a counterfactual against which real outcomes can be compared, controlling for external factors that are unrelated to the ETS. The actual outcome is compared to a modeled one:
- Stakeholder consultation, survey, and desk research: Triangulation approach is adopted, whereby convergence/ dissonance of observations on related questions are obtained through in-depth interviews, surveys, and desk-based research.

- Econometric studies: Statistical techniques are used to compare the outcomes of Designated Water Users before inclusion under the WRC scheme, or with similar users not included in the WRC trading.

As part of the evaluation, the Implementation Agency shall record observations and provide feedback and recommendations based on analyses including but not limited to the following:

- Legal Framework under WRC ecosystem shall be assessed from technical, economical and policy perspective. New regulations/ amendments shall be adopted, if required.
- Institutional structure for implementation of WRC scheme shall be evaluated to assess its robustness and adequacy, and shall include assessment of the following:
 - Delineation of roles and responsibilities/ potential role conflicts.
 - Adequacy of resources involved in different stages of the trading cycle, and
 - Need for training and development for stakeholder ecosystem.
- Degree of achievement against the reuse targets set for each Designated Water User.
- Scheme design with the objective of enhancing achievement, including wastewater reuse and water savings.

- Degree of compliance to ascertain if penalties are adequate to encourage trading. The underlying issues need to be explored to ensure reuse targets are both ambitious and realistic.

Increase market participants

The Implementation Agency shall explore increasing participation in the next WRC trading phase. This may be achieved through deepening and widening of the scheme:

- Deepening the scheme: Refers to inclusion of more Designated Water Users from existing sectors, considering the expected growth rate, potential for wastewater reuse and the associated challenges.
- Widening the scheme: Refers to inclusion of top water-guzzling Designated Water Users from the new sectors, considering the potential for wastewater reuse. Inclusion of new sectors may be based on water withdrawal, number of potential Designated Water Users, existing water-use efficiency in individual process-units, level of complexity in defining normalization, measurement and verification, alignment of sector to WRC design and framework, growth rate of sector and other factors.

To foster innovation, the processes defined shall follow an iterative approach, with the flexibility to make required changes after each phase.

4. TIMELINE FOR IMPLEMENTATION



The Handbook lays out the steps involved in a WRC scheme. However, prior to implementation of the scheme, there is a need to adopt several steps. These pre-implementation steps are indicated in Table 15.

Table 15: Timelines for implementation of WRC scheme

S.No.	Step	Timeline
1	Stakeholder consultations: Engage with public agencies, industry stakeholders, subject matter experts, universities, academicians, etc. This is critical to build trust, acceptance, and support for the concept, and will require a geography-specific engagement and communication strategy.	3 – 6 months
2	Operational Guidelines: Develop geography-specific guidelines in consultation with the stakeholder ecosystem. This includes developing SOPs for each part of the WRC scheme discussed in Chapter 3 of this Handbook. The illustrative draft guidelines for WRCs issuance and management are provided in Annexure 11; this may be adapted to a specific geography.	3 – 6 months
3	Pilot design and implementation: Run a pilot with selected water users. This will help in developing infrastructure and institutional capacity, and identify bottlenecks in scheme design, methodologies, and institutions.	<ul style="list-style-type: none"> • Year 1: Baseline year • Year 2: Target year • Year 3: Assessment year
4	Evaluation of pilot: Conduct an independent evaluation of the pilot scheme, including whether objectives are met, identifying institutional and procedural improvements, etc. Accordingly, the WRC scheme is adjusted and revised.	3 – 6 months
5	Phase-wise implementation: Implement the WRC scheme in a staggered manner, by increasing the number of sectors and water users over successive phases.	<ul style="list-style-type: none"> • Year 1: Baseline year • Year 2: Target year • Year 3: Assessment year Evaluation of the phase is undertaken over a 3-6-month period, followed by revisions to the scheme for the next phase of trading.

5. ANNEXURES



Annexure 1: Current landscape of wastewater reuse practices

The regulatory environment

With growing recognition of the need for a circular economy model in the water sector, public agencies have promoted wastewater reuse practices through dedicated policies, legislation actions and regulations and directives. Some measures adopted across different geographies are discussed in Table 16.



Table 16: Overview of some interventions to promote wastewater reuse

Geography	Details of intervention
North America	
California, United States of America	In 2009, California adopted its 'Recycled Water Policy,' which was recently amended in 2018 ²⁰ . Adopted by the State Water Resources Control Board, the policy sets a target to increase use of recycled water from 0.714 million acre-feet per year (afy) in 2015 to 1.5 million afy by 2020 and 2.5 million afy by 2030. The policy lays out annual reporting requirements for the volume of recycled water produced and used, and volume of wastewater treated and discharged. Also, the state passed a legislation to set a deadline of 2023 for developing regulations for raw water augmentation. Further, the State Water Resources Control Board has adopted regulations to augment reservoirs with treated recycled water.
Mexico	In Mexico, income tax regulations have provisions for accelerated depreciation of assets used for water recycling and reuse. Also, the Comisión Nacional del Agua – the National Water Commission – provides a fee to wastewater treatment plants based on the quantum of treated wastewater being reused. ²¹
South America	
Brazil	In 2005, the Federal Government passed a legislation establishing criteria, procedures and guidelines for water reuse for non-potable purposes. Water reuse has been envisioned for urban use, agriculture and forestry use, environmental use, industrial use, and aquaculture use. ²²
Europe	
European Union	In 2020, the European Parliament passed a legislation defining minimum reclaimed water quality requirements for agricultural irrigation, minimum frequencies for monitoring of reclaimed water, among others. This legislation will come into effect from June 2023 and is expected to promote water reuse in agricultural irrigation ²³ .
Italy	In Italy, the Emilia Romagna Region provides grants to the petrochemical sector, encouraging adoption of water reuse technologies, and provides financial incentives to the agricultural sector for installing water re-usage devices.
Spain	Under Royal Decree 1620/2007, Spain established basic conditions for wastewater reuse, including laying out authorized uses of reclaimed water (urban, agricultural, industrial, recreational and environmental uses), the quality criteria to be maintained, procedures for reuse of treated wastewater, among others. ²⁴

20. Water Quality Control Policy for recycled water, 2018, accessed January 5, 2020, https://www.waterboards.ca.gov/board_decisions/adopted_orders/resolutions/2018/121118_7_final_amendment_oal.pdf

21. Addressing water scarcity through recycling and reuse: A menu for policymakers' perspective on Latin America, Brazil, and Mexico, accessed January 7, 2020, https://watereuse.org/wpcontent/uploads/2015/01/Addressing_Water_Scarcity_in_LAM.pdf

22. Addressing water scarcity through recycling and reuse: A menu for policymakers' perspective on Latin America, Brazil, and Mexico, accessed January 7, 2020, https://watereuse.org/wpcontent/uploads/2015/01/Addressing_Water_Scarcity_in_LAM.pdf

23. Regulation (EU) 2020/741 Of The European Parliament And Of The Council, 2020, accessed January 11, 2021, <https://eur-lex.europa.eu/eli/reg/2020/741/oj>

24. Spanish Regulations for Water Reuse, Royal Decree 1620/2007, 2011, accessed January 11, 2021, https://www.iwa-network.org/filemanager-uploads/WQ_Compendium/Database/Selected_guidelines/042_2.pdf





Geography	Details of intervention
Middle East	
Israel	In 2010, Israel introduced strict quality standards for 36 effluent parameters, with the objective of upgrading wastewater treatment infrastructure to tertiary treatment plants. This treated wastewater was intended to reduce the dependence on freshwater for agriculture. ²⁵
Asia	
China	In 2016, the Ministry of Finance passed an interim measure where users of recycled or reclaimed water in the Hebei province are exempt from water resources tax. ²⁶
India	<ul style="list-style-type: none"> In 2018, the Ministry of Power, Government of India mandated the use of treated wastewater from Wastewater Treatment Plants of municipal bodies for thermal power plants located within 50 km radius of the WWTP.²⁷ In 2017, the state of Karnataka, a major industrialized state of India, formulated the policy for wastewater reuse in urban centers with support from 2030 WRG. The policy provides a comprehensive framework for wastewater reuse in the state, integrating principles of cost recovery, equity, and sustainability for urban wastewater management.²⁸
Singapore	To promote the use of NEWater (high-grade reclaimed water), Singapore has defined its tariff structure so that NEWater is available at a lower tariff than regular water. Also, Singapore does not levy any Water Conservation Tax or water treatment fees on the sale of NEWater. ²⁹
South Korea	The government passed a legislation 'Promotion of and Support for Water Reuse Act' that public wastewater treatment facilities with a capacity of more than 5,000 m ³ per day are obligated to reuse at least 10% of the treated wastewater. ³⁰

25. New Standards for Treated Wastewater Reuse in Israel 2007, accessed January 11, 2021. https://www.researchgate.net/publication/225262222_New_Standards_for_Treated_Wastewater_Reuse_in_Israel

26. China's Water Resource Tax Reform, accessed January 13, 2021. <https://www.chinawaterrisk.org/resources/analysis-reviews/chinas-water-resource-tax-reform/>

27. Water reuse in India: Current perspective and future potential, 2020, accessed January 13, 2021. <https://doi.org/10.1016/bs.apmp.2020.07.011>

28. Karnataka Cabinet Approval of Urban Waste Water Reuse Policy, accessed January 15, 2021. <https://www.2030wrg.org/karnataka-cabinet-approval-of-urban-waste-water-reuse-policy/>

29. Water Price, Singapore's National Water Agency, accessed January 15, 2021. <https://www.pub.gov.sg/watersupply/waterprice/>

30. Promotion of and support for water reuse act, 2010, accessed January 18, 2021. <http://extwprlegs1.fao.org/docs/pdf/kor102411.pdf>



The means of financing

While regulatory interventions are critical to promote wastewater reuse, there are various means to finance development of reuse projects. Some illustrations are provided in Table 17

Table 17: Illustrations for financing reuse infrastructure

Means of financing	Illustration
Budgetary allocations of government entities	<p>Groundwater recharge project in California, United States of America³¹</p> <p>Southern California has limited water resources and low annual rainfall. In response, the Montebello Forebay Groundwater Recharge Project was implemented in south-eastern Los Angeles County. This project involved taking treated wastewater from the Whittier Narrows Water Reclamation Plant and recharging groundwater in the Central Basin. The cost of the plant was provided by the County of Los Angeles. This project has been operational since 1962 and has since then helped in providing a new water supply roughly equivalent to demands of over 0.25 million people.</p>
Tax Collections	<p>Federal sewage tax adopted by Switzerland³²</p> <p>Release of micropollutants in water bodies has been a major concern for Switzerland. In response, the Federal Government, in 2016, revised the Water Protections Act, according to which micropollutant removal systems are to be developed in the following categories of wastewater plants: serving 80,000+ inhabitants, serving 24,000+ inhabitants and discharging into lakes, and serving 8,000+ inhabitants and discharging into rivers, if the discharge represents more than 10% of the minimum flow.</p> <p>With 100 of the country's 700 wastewater treatment plants needing upgradation, the cumulative investment required is estimated at approx € 1 billion. To finance this investment, the Federal Government announced a tax of € 9 per person per annum, from 2016 to 2040, to be paid by individuals connected to a wastewater treatment plant. The revenue from tax collections is expected to meet nearly 75% of the investment requirements, with the remaining investment and operations costs expected to be covered by municipalities.</p>
Private investment, through Public Private Partnerships	<p>High-grade reclaimed water in Singapore³³</p> <p>The Public Utilities Board, Singapore launched NEWater (high-grade reclaimed water) in 2003, with the opening up of two reuse plants – the Bedok and Kranji plants. Currently, the Public Utilities Board has successfully implemented several wastewater reuse plants on PPP mode to produce NEWater, including the Changi I and Chang II plants which have been implemented on a Design-Build-Own-Operate model. NEWater is currently meeting approximately 40% of Singapore's total water demand and is expected to meet 55% of Singapore's future water demand by 2060.</p>

31. Four Decades of Successful Recharge at the Montebello Forebay, 2009, accessed January 18, 2021. https://www.researchgate.net/publication/268115651_Four_Decades_of_Successful_Recharge_at_the_Montebello_Forebay

32. Financing Water Supply, Sanitation and Flood Protection: Challenges in EU Member States and Policy Options, accessed January 18, 2021. <https://www.oecd-ilibrary.org/sites/4624be86-en/index.html?itemId=/content/component/4624be86-en>

33. Our Water, Our Future, Singapore National Water Agency, accessed January 18, 2021. <https://www.pub.gov.sg/Documents/PUBOurWaterOurFuture.pdf>



Depending on end-user quality requirements, reuse projects are technology-intensive and require significant financial investments – for capital expenditure and for operations & maintenance. Given the constraints in the financing environment in many countries, there is a need to supplement conventional means of financing with alternative financing strategies. One such means of financing is the environmental trading or cap-and-trade model, as has been adopted for environmental pollution abatement. An example of the cap-and-trade model designed for the water sector is that by the United States Environmental Protection Agency (US EPA) for water quality trading, as discussed in Exhibit 5.

Exhibit 5: US EPA's Water Quality Trading System³⁴

The US EPA issued the Water Quality Trading Policy in 2003, to develop and promote water quality trading programs. The water quality trading system allows one point source to over control for a pollutant, claim credits equivalent to the over control and then sell these credits to another source that is unable to reduce pollutants as cost-effectively. In this manner, water quality is enhanced in a cost-efficient manner. Also, this market mechanism allows for financing of innovative pollution control measures.



34. EPA's Water Quality Trading Policy, 2003, accessed January 19, 2021, https://www.everycrsreport.com/files/20030129_RS21403_27b7a5dca649327bccd6e8b79c1f5957037f9b17.pdf

Annexure 2: Concepts and examples of environmental trading

The following principles have played a key role in the formulation of environmental policies in different geographies.

Figure 34: Board principles of environmental policy

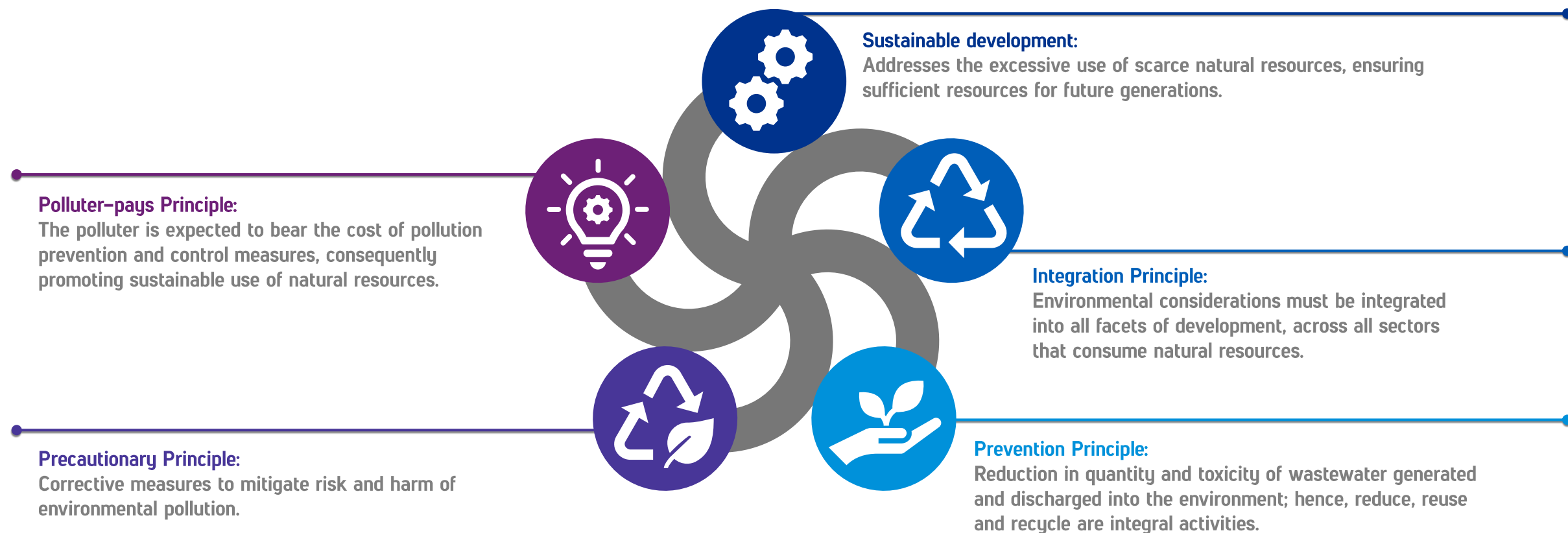



The polluters-pay principle has been recognized under several international conventions for environmental concerns, and numerous countries have integrated it into their respective policy and regulatory framework. While the principle has widespread acceptance, policymakers have explored different measures to implement it. These measures can be categorized into three types – voluntary measures, command-and-control measures, and market-based measures, and these are discussed in Table 18.

Table 18: Overview of measures to implement polluters-pay principle

S.No.	Type of measure	Description	Advantages	Disadvantages
1	Voluntary measures	Voluntary agreements entered into by polluters to reduce pollution, like environmental management standards that polluters may opt to comply with.	<ul style="list-style-type: none"> Efficient in the presence of a certain degree of regulatory environment, rather than in a completely unregulated environment.³⁵ 	<ul style="list-style-type: none"> Uptake and scale might be limited and inefficient in an unregulated setting.
2	Command & Control measures	Pollution control norms laid out by regulators and compliance enforced through threat of punitive action, process/ equipment specifications & standards, information disclosure.	<ul style="list-style-type: none"> Effective for highly-toxic pollutants requiring immediate redressal Effective when the outcome is clear and known and the procedures for implementation of the measures are clearly understood 	<ul style="list-style-type: none"> Cost-inefficient as uniform regulations are imposed on all polluters Requires high cost of regulatory oversight, with the regulator required to have information on industries and abatement technologies Marginal abatement cost of polluters to be either be uniform or known Provides little flexibility for firms to pursue pollution abatement through innovative technologies or solutions³⁶
3a.	Market based measure – Taxation	Imposition of a pre-determined price, where users pay for each unit of pollution caused. This is proposed as a means to change prices and subsequently influence behavior of polluters. Firms are expected to internalize the externality cost and work towards minimizing its cost, and in turn societal cost.	<ul style="list-style-type: none"> Reflects incremental damage caused by every additional unit of pollution Allows individual firms to decide whether or not to invest in pollution control measures and if so, to what extent Transparent and easily understandable by all stakeholders Generates revenue for the regulator, and this can be used for environment protection and conservation measures 	<ul style="list-style-type: none"> Difficulty in arriving at an appropriate level of taxation, due to challenges in assessing the exact impact of a tax rate on the level of pollution Need for international coordination and uniformity on taxation, as high rates of environmental taxation can encourage businesses to relocate to lower-taxed jurisdictions, thus offsetting the benefits of system.

35. Coglianese, Cary and Nash, Jennifer. "Motivating Without Mandates: The Role of Voluntary Programs in Environmental Governance" (2016). Faculty Scholarship at Penn Law. 1647.

36. Bei Zhang (2013) Market-based solutions: An appropriate approach to resolve environmental problems, Chinese Journal of Population Resources and Environment, 11.1, 87-91. DOI: 10.1080/10042857.2013.777526



S.No.	Type of measure	Description	Advantages	Disadvantages
3b.	Market based measure – Cap-and-trade systems	The regulator sets a total permitted quantity of emissions, determines the corresponding total number of allowances, and distributes these transferable allowances among firms. Firms that keep their emissions below the allotted level may sell their surplus allowances to other firms. The economic benefits of a cap-and-trade system are further elaborated in Annexure 1.	<ul style="list-style-type: none"> • Ensures cost efficiency by encouraging economical pollution abatement • Incentivizes innovations to enhance improve environmental performance, as undiscovered technologies may be the most-cost effective solution to pollution abatement • Provides a long-term policy signal, allowing firms to plan their investments • Role of the regulator is limited to monitoring and verification of the environmental performance and maintaining the integrity of the system 	<ul style="list-style-type: none"> • Price volatility may result in inefficiency and collapse of the system. • Absence of proper baselining and allocation principles will lead to inequitable allocations of targets and may lead to long-term failure of the scheme.

The economic rationale for cap-and-trade systems is elaborated in the subsequent sub-section.

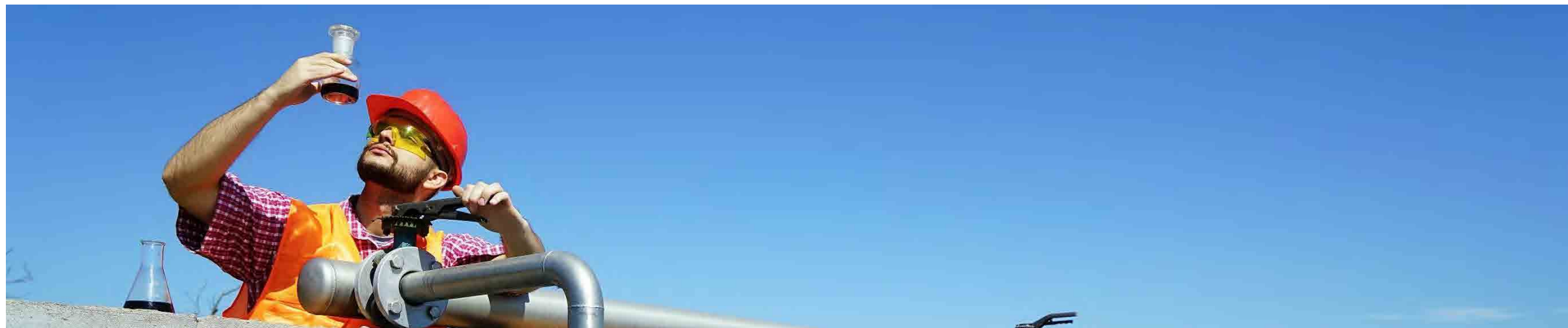

Annexure 2.1: Economic rationale for cap-and-trade systems

As participants to the cap-and-trade system, firms may adopt suitable pollution abatement measures; each firm will have different abatement opportunities that they may implement. Some abatement measures may be inexpensive, while other measures may be technology-intensive and more expensive. In fact, some measures may even have a 'negative' cost associated with it – the firm may derive monetary benefit in adopting

such measures. Usually, the first unit of pollution abatement is relatively inexpensive, but the cost per tonne of pollution abatement rises as more expensive measures are explored, as in the marginal abatement cost function depicted in Figure 35.

Moreover, different firms have different marginal abatement costs, with some firms having lower

costs for pollution abatement than other firms.

This difference in marginal abatement cost across firms provides the basis for trading of permits between firms – firms with higher marginal abatement cost can buy permits from firms with lower marginal abatement costs.

This can be understood by considering a two-firm market – Firm A and Firm B – from the same

industry, manufacturing the same products, having the same pollution of 100 units, but with different marginal abatement costs, as depicted in Figure 36. The marginal abatement cost for Firm A is plotted from left to right, and that for Firm B is plotted from right to left.

Figure 35: Illustrative marginal abatement cost curve for a firm

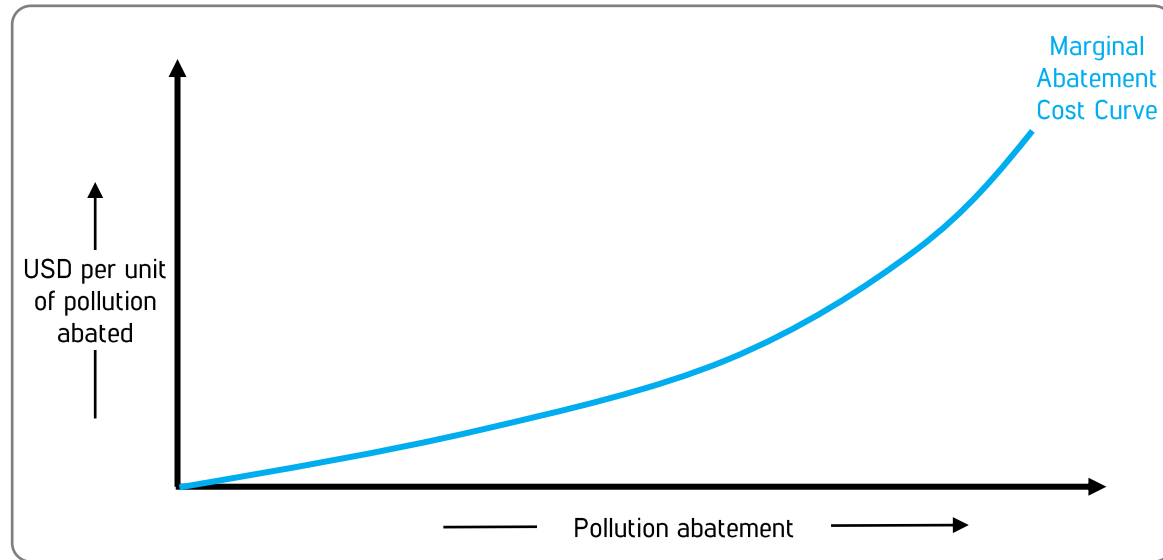
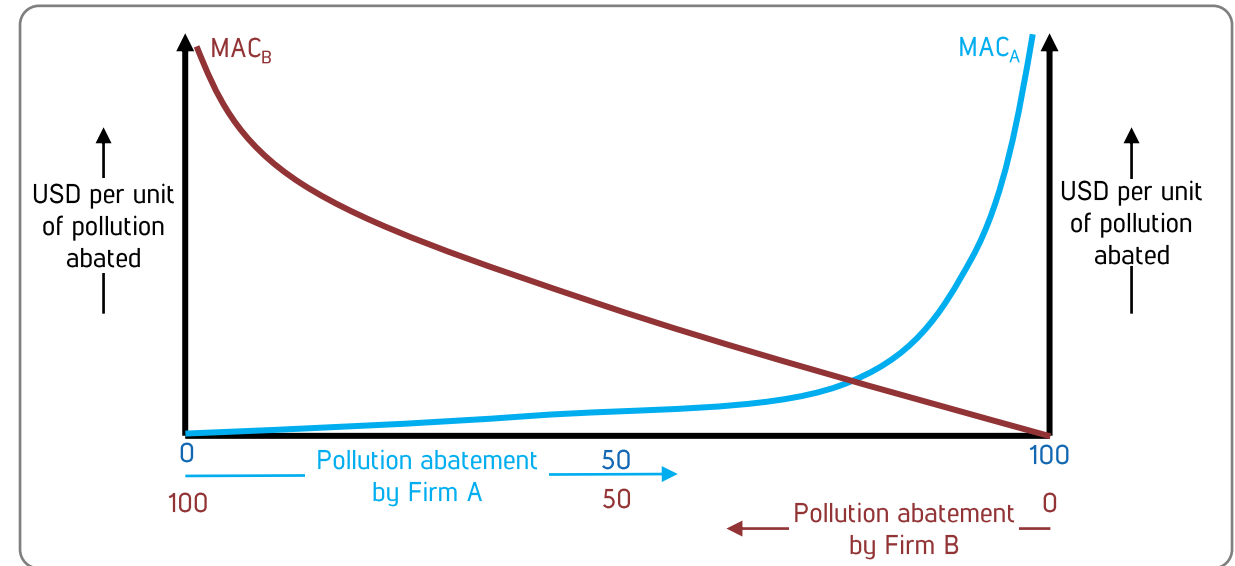

Figure 36: Marginal abatement cost curve for two firms



Now, the regulator aims to limit the total pollution from this two-firm system to 100 units. One way to achieve this target is for the regulator to announce that each firm is expected to limit its pollution to 50 units. As depicted in Figure 37, the total cost of pollution abatement, which is the area under the respective marginal abatement cost

curve, is higher for Firm B (i.e., Area O'XM) than for Firm A (i.e., Area OYM). Hence, while the firms have achieved the targets set by the regulator, the total compliance cost is high.

Now, let us consider that instead of imposing firm-specific limits, the regulator distributes allowances to both firms such that each allowance is equivalent to the right to pollute 1 unit; the total number of allowances distributed are 100. There may be different means of distributing allowances to the two firms. Let us assume a case where

these have been allocated equally to both firms – permits for 50 units of pollution to each firm. In this scenario, firms will trade their allowances until the point where their marginal abatement costs are equal, which is the point Z in Figure 38.

Figure 37: Regulator sets individual emission limits for the firms

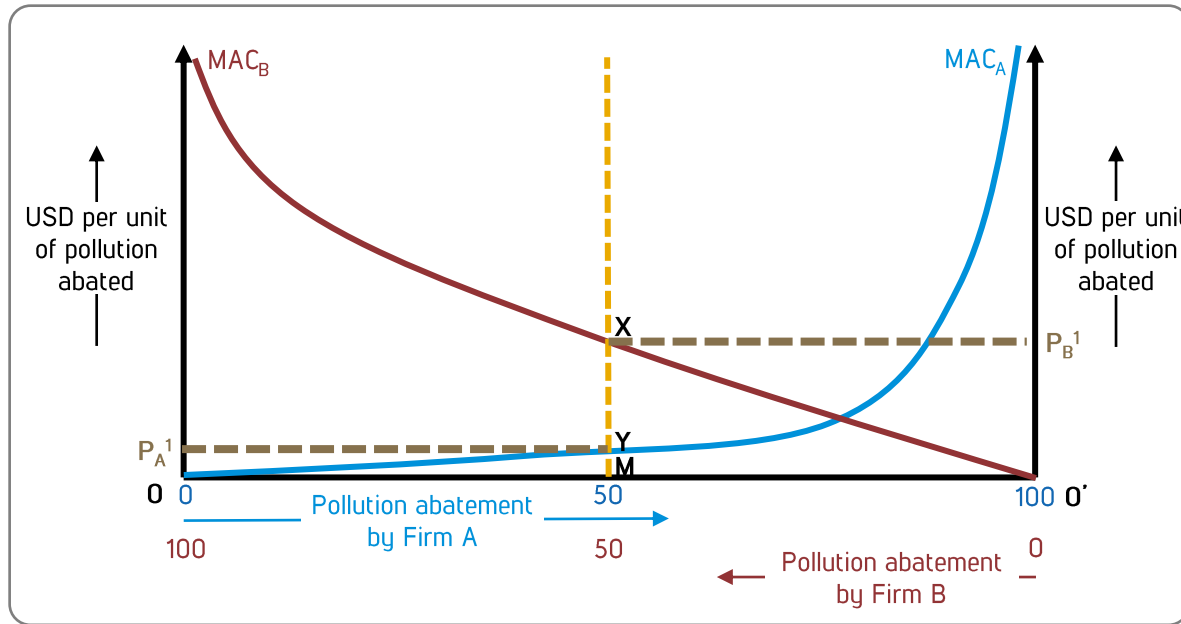
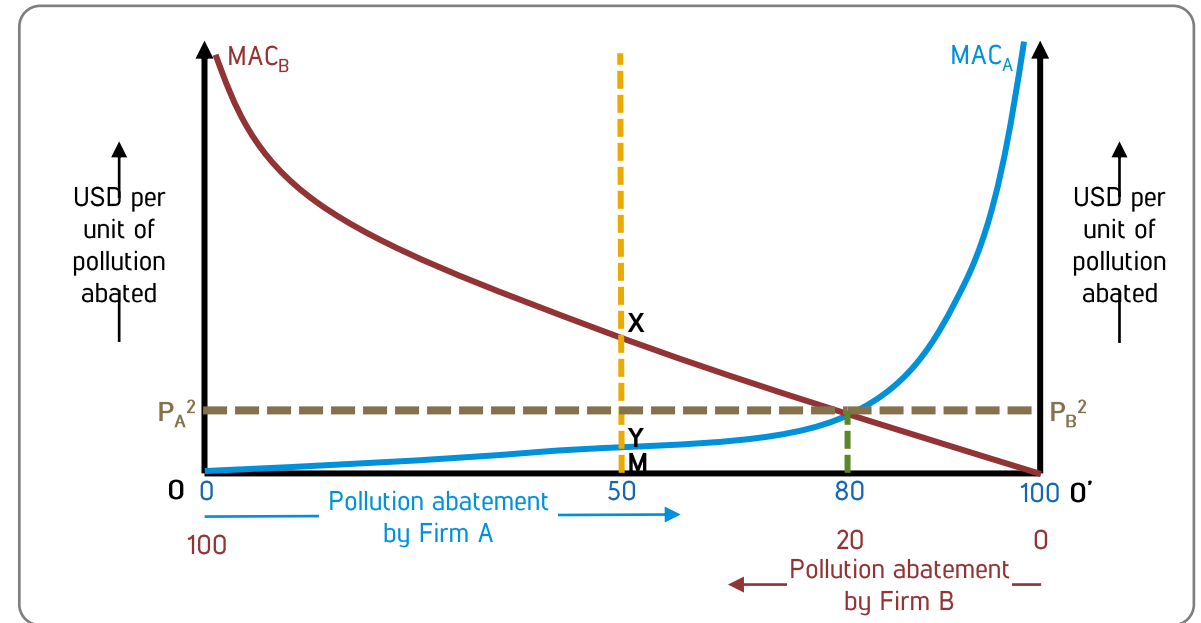

Figure 38: Regulator permits trade of allowances between firms



Trading at point Z ensures that the pollution is reduced in the most cost-efficient manner. Firm A will be willing to reduce its pollution and sell surplus allowances until the point where its cost for adopting pollution abatement measures is equal to the price that it will earn by selling the allowance in the market. Similarly, Firm B will be willing to buy allowances until the point where the cost for adopting pollution abatement measures is equal to the price of allowance in the market. Hence, as depicted in Figure 38, Firm A will ensure pollution abatement by 80 units, and will look to sell the surplus 30 units in the market, while Firm B will ensure pollution abatement by 20 units and will look to buy 30 units in the market. The total cost savings under the trading system is the Area XYZ in Figure 38. Hence, under this system, the target set for total level of pollution is achieved, but at a lower compliance cost for the individual firms and for the system.

In reality, the market system is expected to be more complicated, with a greater number of polluters in the system and a greater number of possible transactions between the participants. However, the economic rationale for a cap-and-trade system remains the same and the trading system allows for pollution abatement in a cost-efficient manner.





Annexure 2.2: Global examples of Cap-and-trade systems

An overview of some cap-and-trade systems implemented in different geographies is provided in Exhibit 6 to Exhibit 10.

Exhibit 6: European Union Emissions Trading System (EU ETS)^{37,38}

Objective:

The EU ETS, the first multi-national cap-and-trade programme, was introduced in 2005, and covers approx. 45% of the EU's emissions. It is a market-based mechanism aimed at reducing emissions in the countries of the European Union. The system is considered as a critical means to achieve the ambitious targets set by the European Commission – of reducing emissions by 80–95% below 1990 levels by 2050.

Scheme design:

Under this system, the total volume of greenhouse gas emissions is capped. Installations and aircraft operators are then allotted allowances, which correspond to the right to emit greenhouse gases such that 1 allowance is equivalent to one tonne of carbon dioxide equivalent (tCO_{2e}). At the end of each year, each participant must return allowances equivalent to its emissions in that year. The performance of each participant is detailed out in a monitoring plan, which is also verified by accredited verifiers. In case a participant falls short of

allowances, it is permitted to buy allowances from other participants in the market.

Achievements:

Three phases of the EU ETS have been operationalized and a fourth phase is planned. Each subsequent phase has widened the geographical spread and emissions covered under the system. Also, the total cap has been decreasing between phases; from Phase 3 onwards, the cap has been decreasingly in a linear manner – such a long-term policy allows participants to optimally plan their investments for emission reduction.

The total ETS emissions from stationary installations have declined by around 29% between 2005 – 2018. ETS stationary emissions are projected to decline by 7% between 2018 – 2030, with existing measures in place. Hence, while the target for 2030 is to ensure reduction by 43% against the levels in 2005, with current measures in place, emissions are projected to decrease by 36% in 2030, compared to 2005 levels.

Challenges faced during implementation:

- The price of carbon allowances exhibited volatility – falling from € 28 in mid-2008 to € 5.8 in 2017. This was on account of accumulated surplus of allowances, which in turn was caused by the economic downturn that had contributed to lower emissions, and significant proportion of credits from project-based mechanisms. This lower price of allowances weakens the incentives to reduce emissions. In response to this, to promote carbon price stability, several short-term, including postponing of auctioning of allowances, and long-term measures, including the Market Stability Reserve (MSR), were adopted.

Key learnings:

- A large cap & trade system like EU-ETS has been able to promote technological and operational innovations, the concrete applications as well as the increased flexibility of the “polluter pays” principle as compared to traditional command-and-control instruments.

- A large cap & trade market can enhance competition among the economic actors involved and increases the possibility of finding buyers for the available allowances, thus encouraging participants to undertake continuous and long-term pollution abatement strategies.
- For the success of a trading system, there is need for a long-term policy certainty. This will allow participants in the trading system to plan their investments carefully.
- Auction-based allocations of allowances generate revenue for the regulator, and this may be used to fund pollution abatement measures. For instance, under EU ETS, at least 50% of the revenue generated was used to fund measures to tackle climate change in the EU or in the member states.

Status:

The fourth phase of the EU ETS is planned from 2021 – 2030.

37. The EU Emissions Trading System in 2019: trends and projections, accessed January 19, 2021.

38. Causes of the EU ETS price drop: recession, CDM, renewable policies or a bit of everything? – New evidence, accessed January 19, 2021





Exhibit 7: Energy Saving Certificates, under the Perform Achieve and Trade Scheme, India

Objective:

Perform Achieve and Trade (PAT) scheme is a flagship programme of Bureau of Energy Efficiency (BEE) under the National Mission for Enhanced Energy Efficiency (NMEEE). NMEEE is one of the eight national missions under the National Action Plan on Climate Change (NAPCC) launched by the Government of India in the year 2008

Scheme design:

Under the PAT scheme, BEE sets a target for reducing energy consumption for each notified consumer. The specific energy consumption for individual consumers is considered on a 'gate-to-gate' basis and is normalized to account for factors that may be beyond the control of the respective consumer. The targets are set in such a manner that the consumer that is less energy efficient is assigned a higher target vis-à-vis a consumer that is more energy efficient.

The monitoring of the performance of individual consumers is on the basis of energy audits conducted by regulator-empaneled energy auditors. The individual consumers that exceed their targets are issued Energy Savings

Certificates (ESCCerts) (where 1 ESCert is equivalent to 1 tonne of oil equivalent of energy (toe) savings). The consumers then trade the ESCerts on the designated trading exchange – the Indian Energy Exchange – at pre-defined times.

Achievements:

Till date, the PAT scheme has been operationalized in five cycles. The energy savings achieved in PAT Cycle –I is 8.67 MTtoE which was excess of 30% against the target of 6.686 MTtoE. This energy savings translates to avoiding about 31 million tonne of CO₂ emission.

The details of the implemented cycles are as follows:

- PAT Cycle I (implemented over FY2013 – FY2015) had 478 consumers from 8 sectors – Aluminum, Cement, Chlor- Alkali, Fertilizer, Iron & Steel, Paper & Pulp, Thermal Power Plant and Textile.
- PAT Cycle II (implemented over FY2017 – FY2019) covered 621 consumers from 11 sectors (including railways, refineries and DISCOMS); its evaluation is currently underway.

- PAT Cycle III (implemented over FY2018 – FY2020) covered 116 consumers over 6 sectors, with target energy consumption reduction of 1.06 Mtoe.
- PAT Cycle IV (implemented over FY2019 – FY2021) covered 106 consumers over 8 sectors, with target energy consumption reduction of 0.6889 Mtoe.
- PAT Cycle V (implemented over FY2020 – FY2022) covered 110 consumers over 8 sectors, with target energy consumption reduction of 0.5130 Mtoe.

Challenges faced during implementation:

- Risks of price volatility due to ex-post nature of the issuance of ESCerts – during the implementation of the abatement measures, the designated consumers do not have an accurate indication of the marginal cost of abatement.
- Penalties for non-compliance were often not invoked in an effective and time-bound manner during Cycle I, and this often tended to dilute the significance of the scheme.

Key learnings:

- Incremental expansion approach of the scheme over time helped in getting buy-in from new sectors or consumers through showcasing learnings of previous cycles, aided through extensive stakeholder consultations.
- The baseline emission or consumption of resources should be considered on a gate-to-gate basis, like under the PAT scheme where the total energy consumption of the consumer was considered against the total production.
- It is critical to base the system on principles of equity. For instance, under the PAT scheme, the regulator adopted a robust process of normalization and standardized process of energy audits to adhere to these principles
- Target setting may be done on the basis of relative responsibility, with a higher target assigned to a less efficient consumer.

Status:

As on 2020, PAT Cycle IV and Cycle V are currently underway.



Exhibit 8: Renewable Energy Certificates, India

Objective:

In a bid to promote renewable energy market in India, the government has framed policies under the National Action Plan on Climate Change (NAPCC) to increase the total renewable power generation capacity in the country. Renewable Energy Certificates (REC) is a policy instrument to catalyze the development of renewable energy. It is a market based mechanism which helps the states meet their regulatory requirements (such as Renewable Purchase Obligations (RPOs)) by overcoming the geographical constraints on existing renewable potential in different states.

In India, all electricity distribution licenses, are required to purchase or produce a minimum specified quantity of their requirements from renewable energy sources. The Renewable Energy Certificates (RECs), launched in 2010, are a market-based instrument that allows these entities to meet their respective obligations. RECs help in incentivizing the production of renewable energy over and above the RPO state limit as tradable certificates are not constrained by the geographical limitations of commodity electricity.

Scheme design:

The Renewable Purchase Obligations of entities are fixed by the Central and State electricity regulatory commissions. The renewable energy claimed to be generated is certified by state-level agencies – the State Load Dispatch Centres. Accordingly, RECs are issued to the renewable energy generators (with 1 REC is equivalent to 1 MWh energy injected into the grid), and are traded among participants on power exchanges. The obligated entities participating in the trading include large distribution companies, open access companies and captive power consumers, while voluntary entities, including individuals, corporates and non-governmental entities, may also participate in the trading. The trading of RECs takes place within the range of the regulator-defined floor and forbearance prices, which provides a degree of price stability in the market.

Achievements:

The REC mechanism promoted renewable energy generation in the country, with approx. 68.94 mn RECs having been issued since the inception up till September 2020. RECs are expected to play a large role in meeting the ambitious targets set by the Government of India – of renewable energy installation of 175 GW by 2022 and 500 GW by 2030.

Challenges faced during implementation:

- Due to lack of visibility in terms of the future demand and growth trajectory, sale and redemption of RECs sometimes becomes unpredictable during the year. Many utilities prefer buying renewable power rather than reverting to RECs to meet RPO obligations.
- Higher supply of RECs with regulatory uncertainties and lower floor prices have further increased the revenue risks for those renewable projects, which depend on RECs for part of the revenue.
- Lack of stringent actions on state utilities, for non-compliance of RPO obligations often led to lower demand and lower prices.

Key learnings:

- To avoid price volatility, the trading system may define floor and forbearance prices. For instance, in the REC scheme, the CERC defined floor and forbearance prices, which provided price stability and consequently a degree of comfort to the participants, particularly during a mismatch in demand-supply of tradeable units.

Status:

Issuance and trading of RECs is still in progress.



Exhibit 9: Water trading in the Murray-Darling Basin, Australia³⁹**Objective:**

This is a cap-and-trade market for the water sector that is operational in the Murray-Darling river basin in Australia.

Scheme design:

Under this trading system, a cap was defined on the total water abstraction, and the users are then allowed to trade their water rights between each other. The water is traded on markets within catchments, between catchments or along river systems. Two types of water rights are defined – water entitlements, which refers to ongoing shares of the total amount of water available in the system, and water allocations, which refers to the actual amount of water available under water entitlements in a given season.

The water market allows for two types of trade – permanent trade (involves trade of water access entitlements) and temporary trade (involves trade of water allocations). The trades may be undertaken by federal & state governments (for environmental purposes), irrigators, environmental non-governmental organizations and investors. The governments of New South

Wales, Queensland, South Australia and Victoria are responsible for managing water markets, and each state defines its own rules. Trading is facilitated by one of several operating water exchanges, like Murray Water Exchange and Waterexchange.

Achievements:

The trading system allows for realizing maximum economic value of water, with higher-value uses being prioritized. Currently, the Murray-Darling basin constitutes 80–90% of all trading activity in Australia, with annual water traded in the basin estimated to be around USD 1.4 bn.

Challenges faced during implementation:

- Limited availability and quality of information related to water prices, as collected by state government agencies. Also, while water price data is presented on various water exchanges, each exchange is a reflection of a small proportion of the market – there is limited visibility on the prevailing market prices over the entire water market.
- There exists a fragmented governance structure, with different bodies overseeing

water markets under different legal frameworks and overlap of roles & responsibilities. This has resulted in confusion among market participants and lack of confidence in the water markets.

Key learnings:

- Transparency and information symmetry among stakeholders is critical for the success of a cap-and-trade system.
- Long-term policy stability allows for long-term effective planning by participants.

It is critical that the system adopts an incremental approach to trading, with a robust feedback loop. Accordingly, the design of the system may be revised based on learnings from earlier phases of trading.

Status:

The water market is operational, and trading is still in progress.

39. Water markets and trade, accessed January 20, 2021. <https://www.mdba.gov.au/water-management/managing-water/water-markets-trade>



Exhibit 10: Clean Development Mechanism, under the Kyoto Protocol⁴⁰**Objective:**

Clean Development Mechanism allows Annex-1 countries (industrialized nations/developed nations) to sponsor GHG reduction projects in non-Annex-1 (developing nations) countries. The emission reductions through projects that take place in the non-Annex 1 country can be used by the sponsor Annex-1 country to fulfill its targets.

Scheme design:

Under this system, projects implemented in developing countries could earn Certified Emission Reductions, depending on the emission reduction achieved (where 1 CER is equivalent to one tonne of carbon dioxide). The CERs earned by these projects could be traded and sold to industrialized countries, to help them meet their legally-binding obligations under the Kyoto Protocol. The scheme design also validates sustainable development under various facets like climate action, economic well-being, social well-being, technology transfer for each project. The CDM mechanism was based on the principle of additionality, where projects had to exhibit emission reduction over and above the business as usual scenario. Also, under the

CDM, the monitoring of projects and their emissions is done by an independent, accredited third-party.

Achievements:

Over 2001 – 2021, there have been 7,837 registered projects, with an emission reduction of approx. 2 billion tCO₂e in the developing world. Through the CDM, over 2011 – 2021, the total investment in climate and sustainable development projects was more than USD 300 bn. Of the CDM's projects, more than 70% are in the renewables sector, with a major focus on wind and hydro projects. Wider benefits of CDM projects include investment in climate change mitigation projects in developing countries, transfer or diffusion of technology in the host countries, as well as improvement in the livelihood of communities through the creation of employment or increased economic activity.

Challenges faced during implementation:

- The establishment of the concept of “additionality” often raised criticism especially for projects in India and China wherein it is often alleged that multiple projects in these countries would have

occurred under business as usual scenario considering the fast pace of economic development in these nations

- Although in the scheme design, equity principles were embedded, due to sheer sizes and pace of growth of these economies, India and China accounted for bulk of the credits. This often challenged the equity principles wherein the least developed nations could not get benefits to the extent it should have
- The economic downturn or the Eurozone debt crisis led to a prolonged reduction in demand from Annex I / developed nations leading to a substantial oversupply of CERs during that period leading to a permanent plunge in prices

Key learnings:

- The CDM was based on the stringent principles of additionality which meant that the projects must reduce emissions over and above the business as usual scenario.
- The design of the CDM mechanism was based on the principles of equity, with assistance was intended to be provided to

developing nations from developed nations in achieving sustainable development

- CDM projects, especially in the energy sector, had significant gender-positive impact. For instance, project activities that had significant impacts include those offering cleaner, efficient and affordable energy for cooking, lighting and electrical appliances in rural households that earlier relied on traditional fuels, like dung, coal, etc.

Status:

The trading market for CERs collapsed in 2012 and international discussions are currently underway to consider the future use of CDM CERs.

40. Clean Development Mechanism Passes New Milestone. accessed January 20, 2021. <https://unfcccint/news/clean-development-mechanism-passes-new-milestone>



Based on the study and evaluation of these cap-and-trade systems, it is evident that critical success factors for cap-and-trade system are:

- The basis for allocating pollution caps, targets for pollution abatement, and scope of sectoral coverage should be based on transparent scientific mechanisms of baseline determination, taking into consideration historical performances, and include stakeholder consultations, wherever feasible.
- Adopt instruments to reduce price volatility and promote trade of allowances.
- Define transparent and robust protocols for monitoring and verification of performance and functioning of the online trading platform.
- Regulators must ensure information symmetry, i.e., information related to activities involved in the system, like determination of caps, distribution of allowances, procedures for trading, market prices, etc., is accurate and available to all stakeholders.

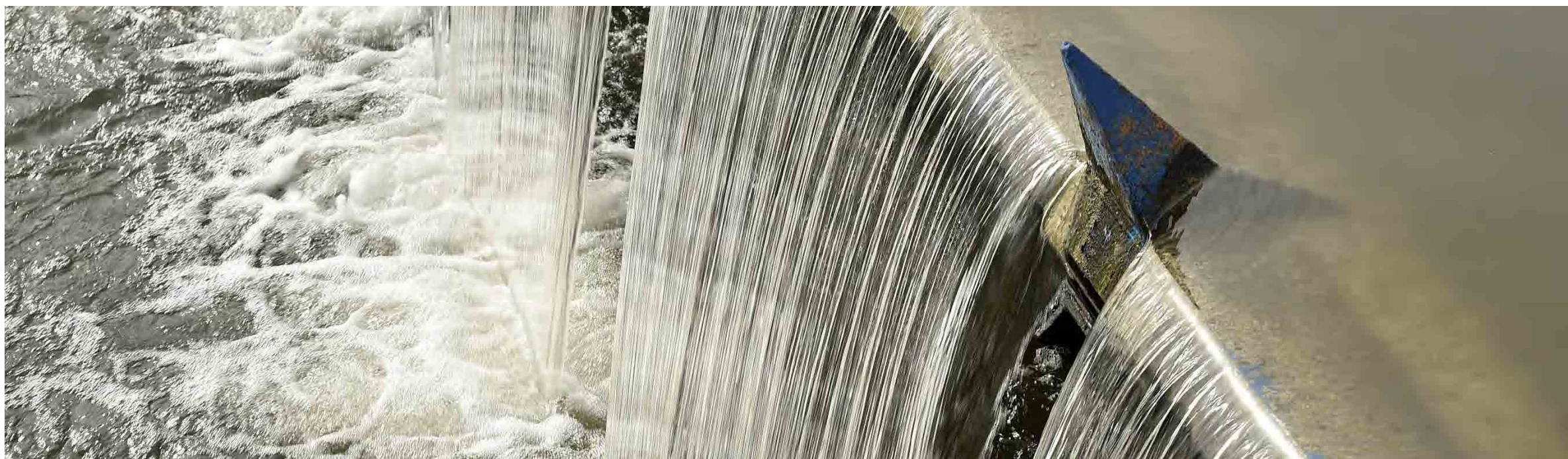

Annexure 3: Roles and Responsibilities of actors under WRC scheme

The activities⁴¹ involved in the implementation of the regulated and voluntary approaches are elaborated in Table 19.

Table 19: Roles & responsibilities of key actors under WRC scheme

S.No.	Activities	Responsibility	
		Regulator-driven scheme	Voluntary scheme
1	Formulate operational guidelines for implementation of the WRC scheme	Regulator	Anchor Entity
2	Designate independent agency for dispute resolution related to water audits conducted for the WRC scheme	Regulator	Anchor Entity
3	Define mechanism of issuance of WRCs to water users in line with their performance	Regulator	Anchor Entity
4	Finalize mechanism for price discovery of WRCs on Exchange	Trading Exchange and Regulator	Trading Exchange and Anchor Entity
5	Conduct information dissemination events with key stakeholders to spread awareness on the WRC trading scheme	Regulator	Anchor Entity
6	Develop the web portal (WRCNet Portal) and maintain data storage facilities	Administrator	Administrator
7	Act as web administrator for the WRCNet Portal	Administrator	Administrator
8	Develop IT Platform compatible with WRCNet Portal for enabling online transaction of WRCs	Trading Exchange	Trading Exchange
9	Designate individual water users to participate in the WRC scheme	Regulator	Not Applicable
10	Register on WRCNet Portal by submitting required detail, supporting documents and processing fee (as required), on notification by Implementation Agency	Designated Water User	Designated Water User
11	Undertake registration of all Designated Water Users for each phase of trading, and accordingly issue 'Certificate of Registration' to the respective users	Registry	Registry

41. The detailed characteristics of the various actors in the WRC ecosystem are discussed in Table 1 and Table 2 of this Handbook.



S.No.	Activities	Responsibility	
		Regulator-driven scheme	Voluntary scheme
12	Install meters and sensors for monitoring of performance, as per pre-defined specifications; also ensuring the data feed is given to the regulator defined databases	Designated Water User	Designated Water User
13	Empanel accredited water audit agencies for monitoring and verification of performance of Designated Water Users under the WRC trading scheme	Regulator	Anchor Entity
14	Set and notify wastewater reuse targets for designated water users, based on respective established baseline and achievable potential for reuse	Regulator	Anchor Entity
15	Processes applications from Designated Users for credit and interest-rate subvention for development of reuse projects	Not Applicable	Banks/ Financial Institutions
16	Take necessary measures to improve water use efficiency and increase use of treated wastewater by adopting best practices in the respective sector	Designated Water User	Designated Water User
17	Engage empanelled water auditor to assess performance during assessment period	Designated Water User	Designated Water User
18	Conduct independent evaluation of activities undertaken by the Designated Water User for compliance with the defined reuse norms and assigned reuse targets	Water Auditor	Water Auditor
19	Assist in conducting independent review of the audit reports submitted by empanelled user-appointed auditors	Water Auditor	Water Auditor
20	Issue WRCs to designated users based on performance verified by empanelled water auditors	Regulator	Certification Entity
21	Place buy or sell bids of WRCs to Trading Exchange in timely manner	Designated Water User	Designated Water User
22	Verify sufficiency of WRCs against individual user accounts for processing buy/ sell bids during WRC trading windows and accordingly send confirmation or default report, as relevant, to the Trading Exchange	Registry	Registry
23	Facilitate trading of WRCs between Designated Water Users, including determining market clearing price and market clearing volume, issue purchase certificates to the buyers of WRCs and establish dispute resolution mechanism to address disputes in trading of WRCs	Trading Exchange	Trading Exchange
24	Maintain secure database of issued WRCs and records of trade transactions of WRCs	Registry	Registry
25	Provide IT assistance for the WRCNet Portal to other stakeholders during implementation of the trading scheme	Administrator	Administrator



Annexure 4: Registration of users on WRCNet Portal

The Designated Water Users will be directed to perform the following steps:

1. The Designated Water User opens the WRCNet Portal from the link shared by the Registry (<https://<domain>.gov.in/PortalUser/Login?>).

2. On opening the landing page 'Login to WRCNet Portal' (Figure 39), the user indicates that it is a Designated Water User and proceeds to its registration.

Figure 39: Landing page for registering users

3. The Designated Water User then provides basic details as indicated in the **Designated Water User (DWU) Registration Form** (Figure 40), including the sector and sub-sector, as classified by the implementation agency, the

Registration Number and other identifying details.

Figure 40: Designated Water User Registration Form

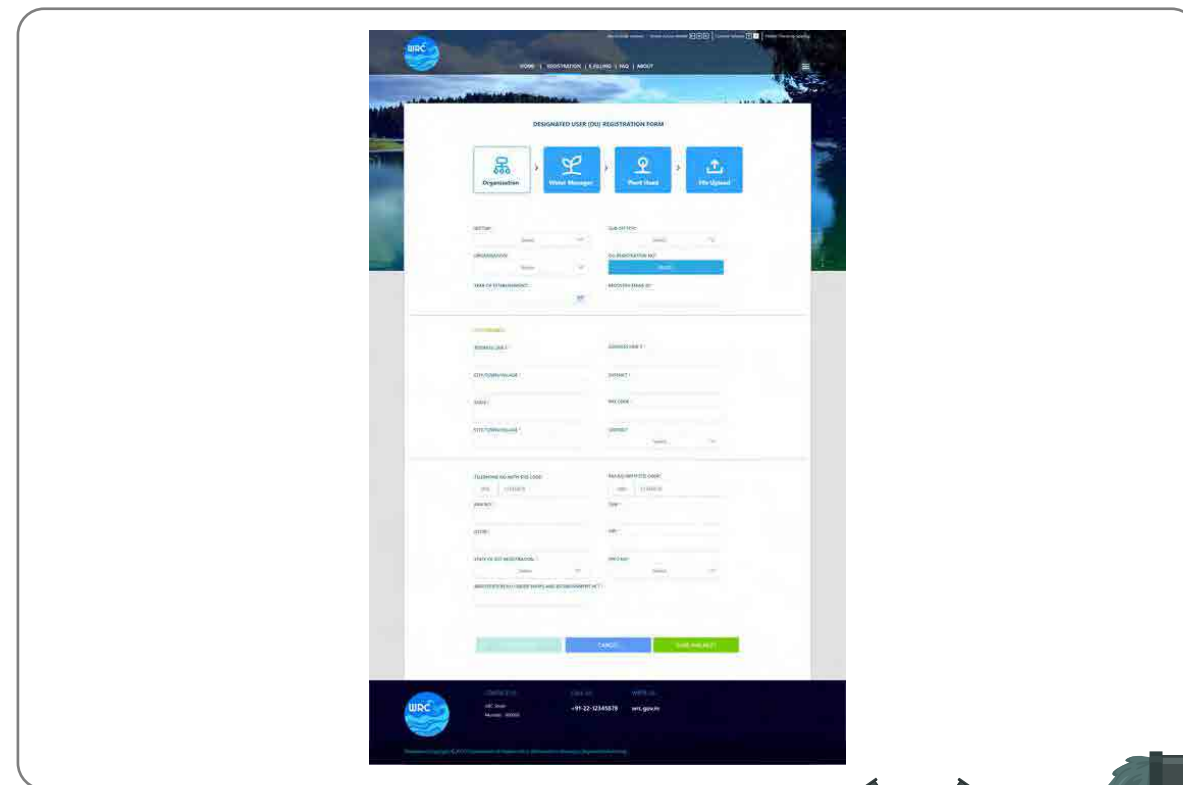
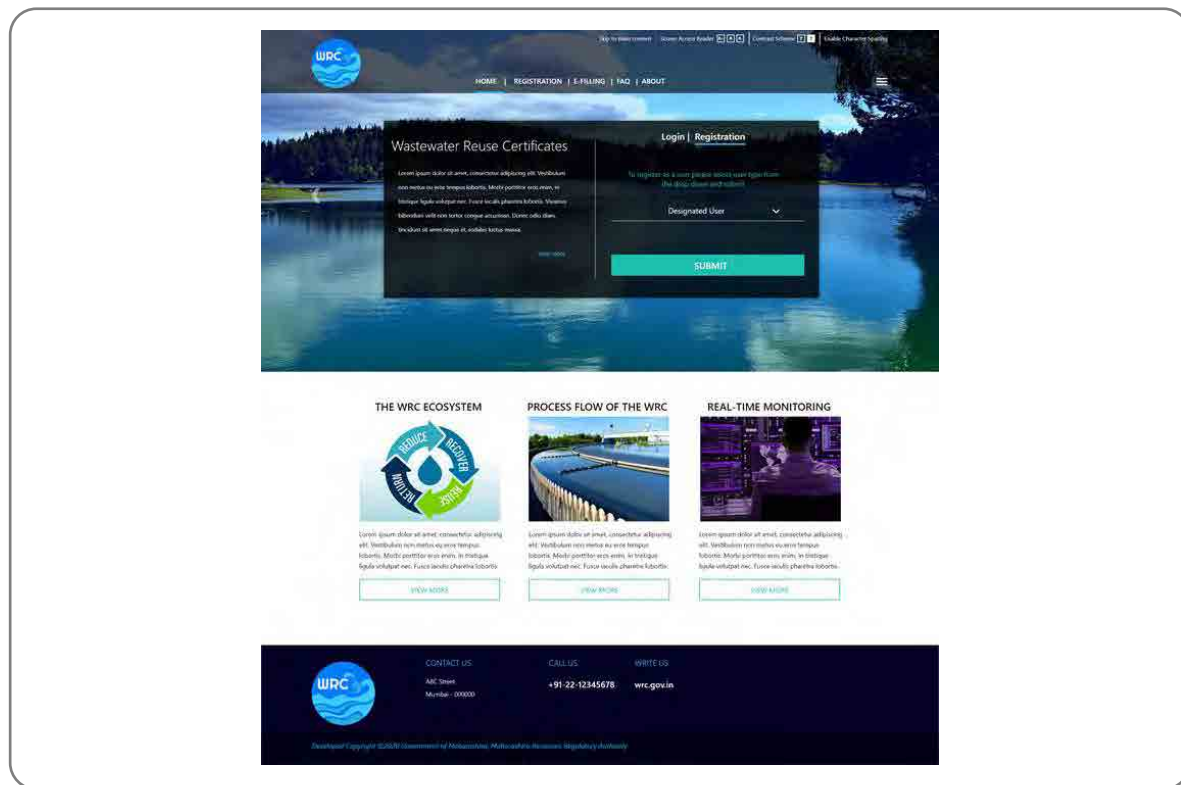

4. The Designated Water User enters the details of the designated Water Manager (Figure 41). The Water Manager is in-charge of activities for efficient water use and wastewater reuse within the water user. In fact, the Water Manager shall be one of two points-of-contact during the WRC scheme, along with the Plant Head.

necessary. Qualified Water Managers shall then be issued a Water Manager Registration Number. The implementation agency may decide to restrict a Water Manager to working for only one Designated Water User at a time.

On the Designated Water User providing the Water Manager Registration number, the details of the Water Manager will be auto-populated.

Figure 41: Water Manager Details on Designated Water User Registration form

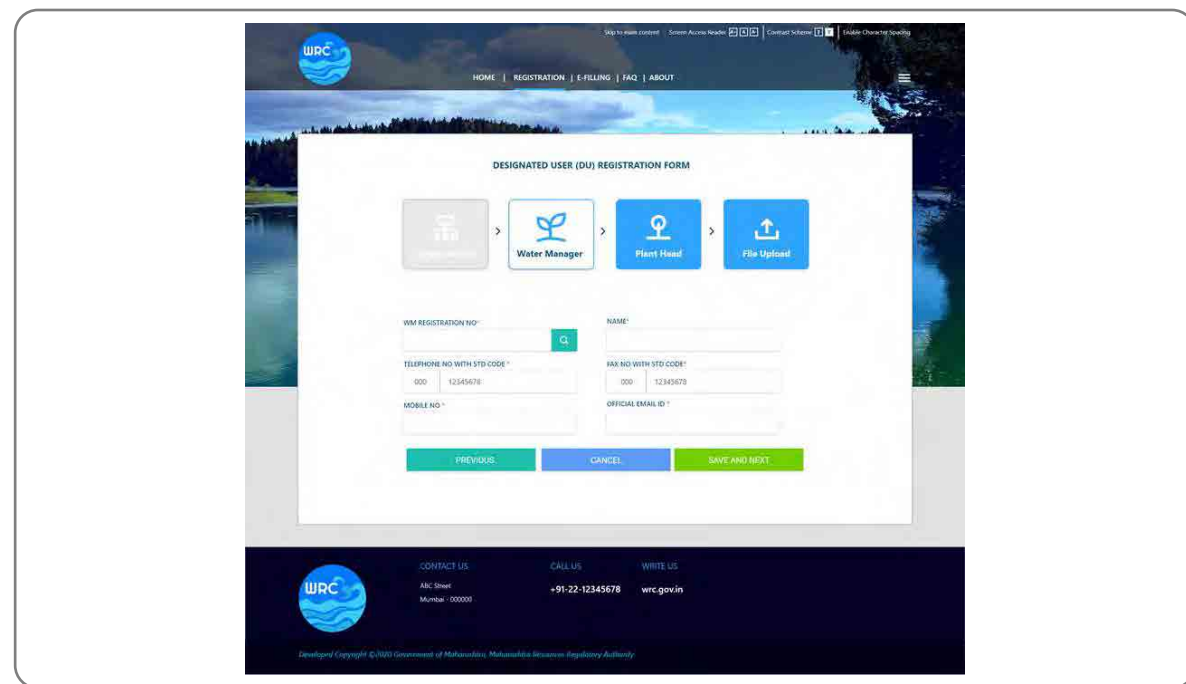

5. The Designated Water User enters the contact details of the Plant Head (Figure 42).

Figure 42: Plant Head Details on Designated Water User Registration form

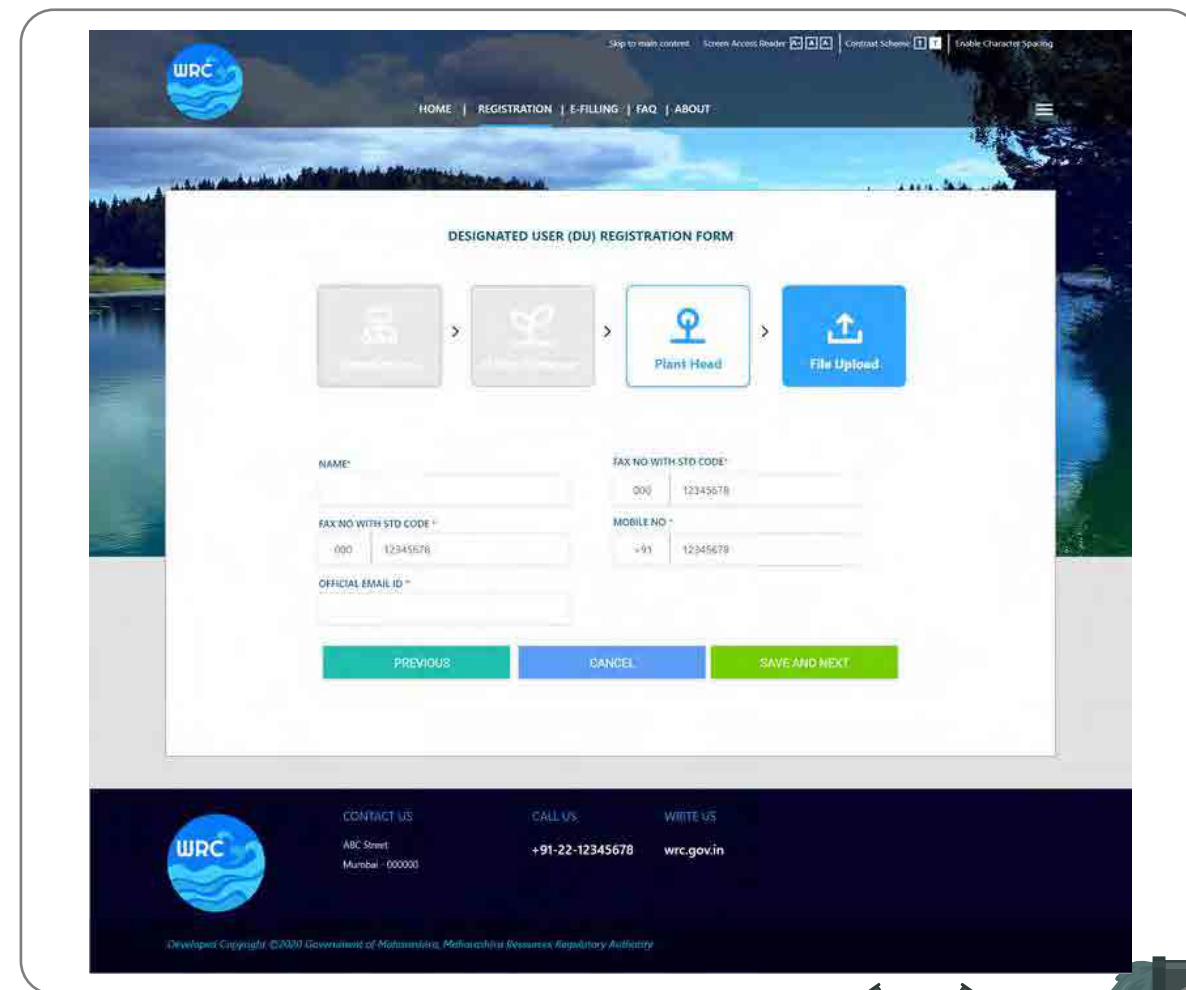

6. The Designated Water User uploads all relevant certificates and supporting documents, including company registration certificate of the entity under the local legislation, the Tax Identification Number, and other supporting

documents as defined by the implementation agency.

Figure 43: File Upload Section on Designated Water User Registration form

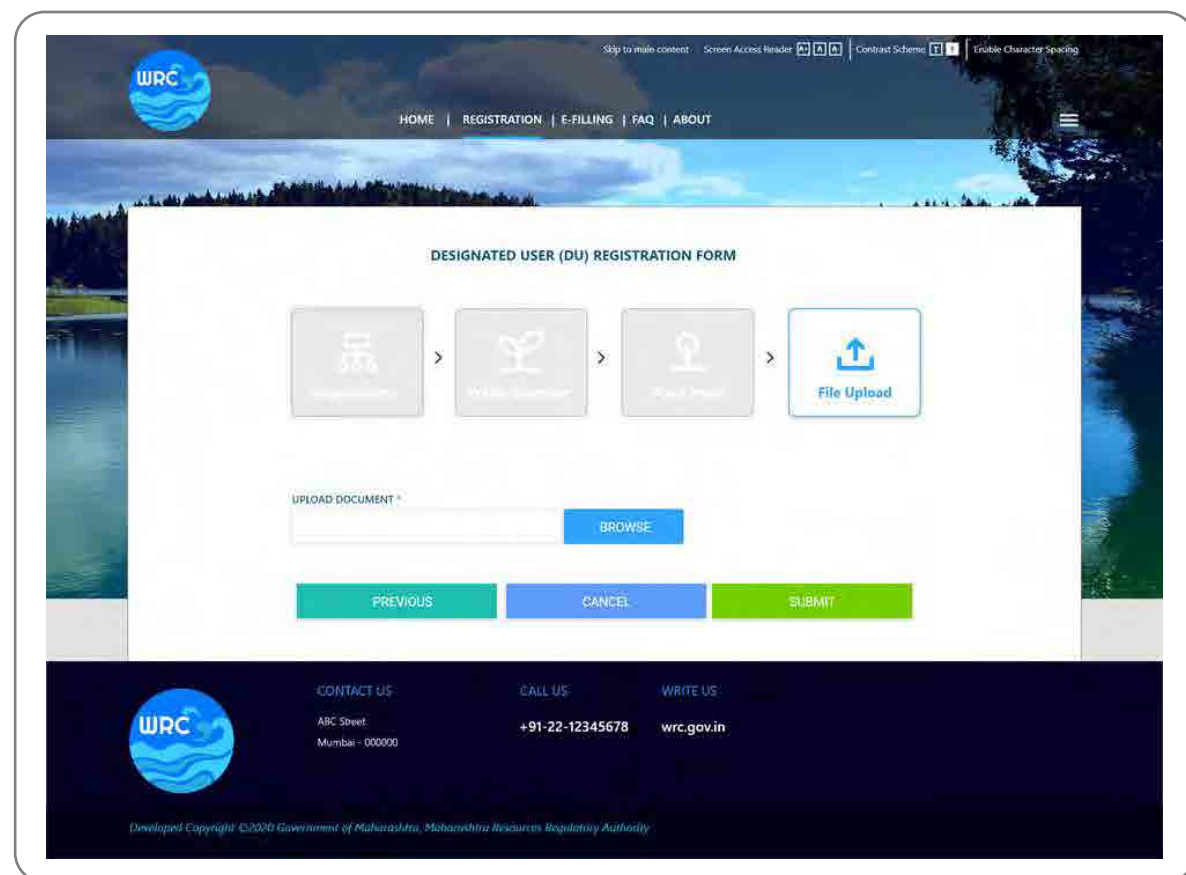
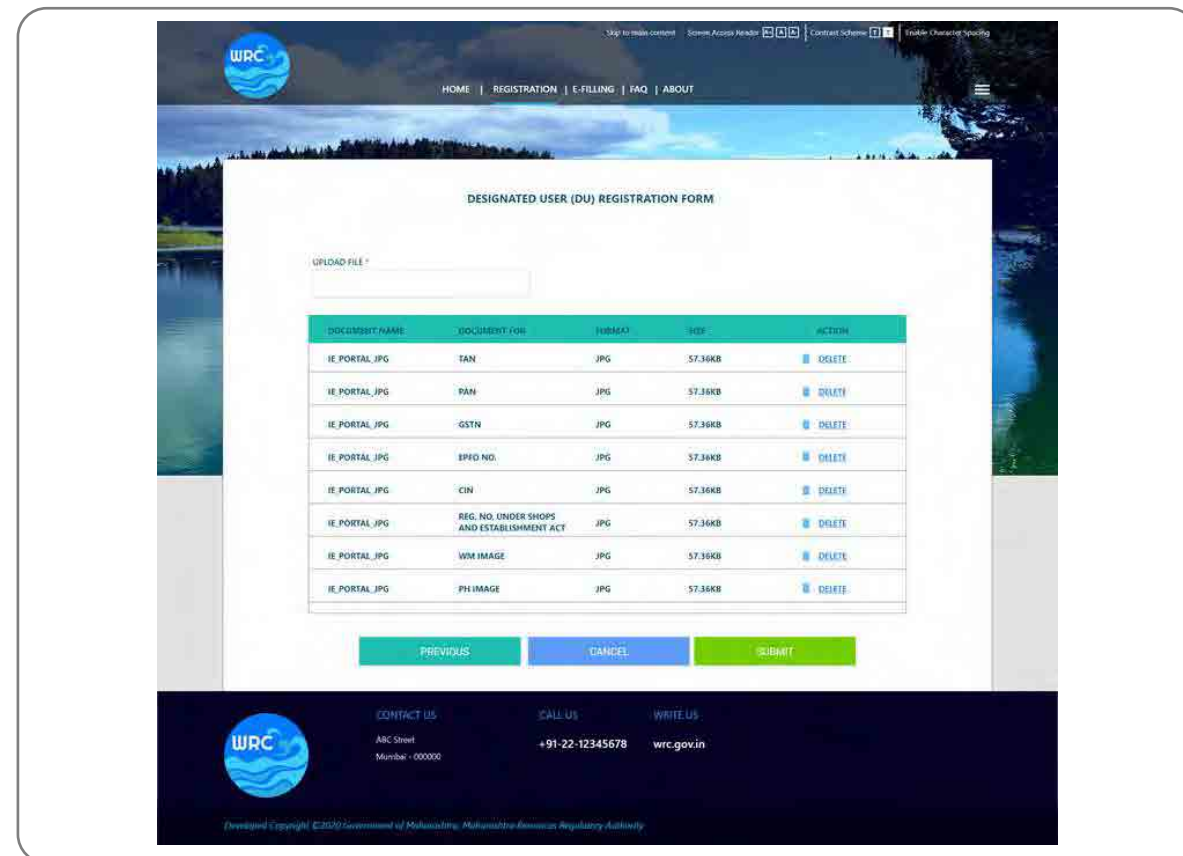

Figure 44: Successfully uploaded files on Designated Water User Registration form



7. On successful registration of the Designated Water User, the Login credentials for both the Water Manager and the Plant Head will be sent to their registered email ids for registration.

Annexure 5: Establishing the baseline

Annexure 5.1: Learnings from global systems

As part of the Clean Development Mechanism, baseline methodologies are defined based on quantum and category of project to determine the amount of the respective Certified Emission Reductions (CERs). An illustrative methodology to establish baseline and additionality under the CDM is as exhibited in Figure 45.

Figure 45: Establishing baseline under Clean Development Mechanism

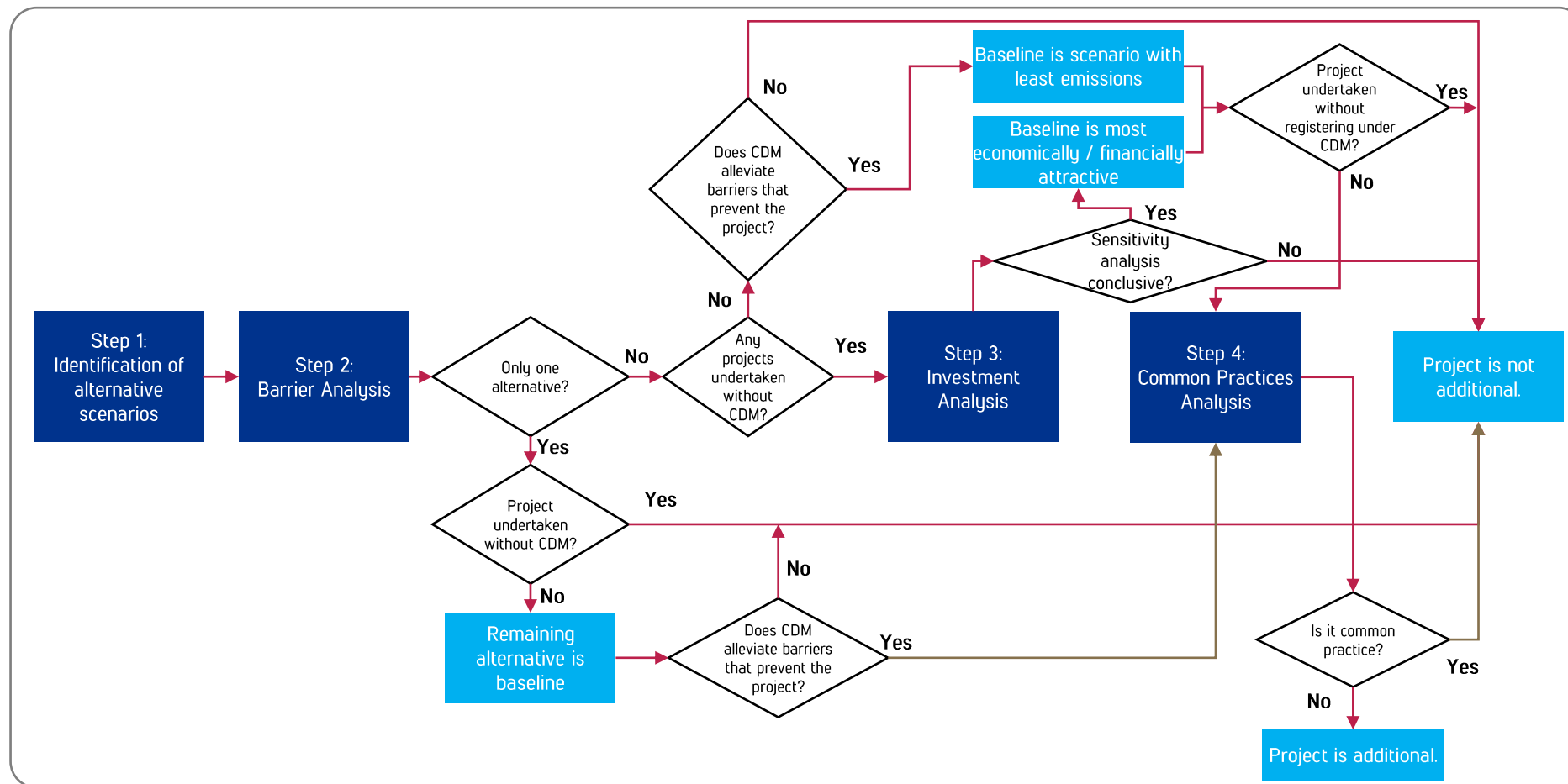

Source: Methodological tool, 'Combined tool to identify the baseline scenario and demonstrate additionality', CDM-Executive Board

Further, the PAT Scheme was implemented in India to reduce energy consumption in industrial sectors, and the methodology for establishing the baseline under PAT is described in Exhibit 11.

Exhibit 11: Establishing baseline under Perform Achieve Trade (PAT) scheme, India

Under the Perform Achieve Trade (PAT) scheme, the baseline production, specific energy consumption and the capacity utilization was computed by calculating the arithmetic average of the values over the past three years.

Moreover, the annual consumption figures were normalized for the capacity utilization, so that no undue advantage or disadvantage of a product is not included in the baseline computation. Some of the normalization factors were considered:

- i. Import & Export of Intermediary product
- ii. Value added product
- iii. Product Mix
- iv. Power Mix (Imported & Exported from/ to the grid and self-generation from the captive power plant)
- v. Specific Energy Consumption calculation of sub-group
- vi. Normalization for Start & Stop of the Plant
- vii. Additional Environmental Equipment requirement due to major change in government policy on Environment

viii. Fuel replacements

ix. Other unforeseen circumstances

For instance, consider the import and export of intermediary products by the industrial plant. Accordingly, the energy consumption for producing the imported product shall be calculated and will be added to the total energy of the plant, while the energy consumption of an exported intermediary product, before the sale of the final production, is subtracted from the total energy.

Then, energy of the imported product = *Export energy of product in baseline year – import energy of product in baseline year*

Where

export energy = total export in baseline year * specific energy consumption in baseline, and

import energy = total import in baseline year * specific energy consumption in baseline.

Annexure 5.2: Illustrative example for establishing the baseline

Let us consider an industrial unit with the historical performance as provided in Table 20.

Table 20: Illustrative historical performance of industrial unit

Parameter	Units	Year 1	Year 2	Year 3
Installed Capacity	MT	370,600	370,600	370,600
Actual production	MT	252,000	326,128	374,300
Water consumption	m ³	52,920,000	63,698,500	74,111,400

Accordingly, on performing the related calculations, the baseline for the industrial unit is as provided in Table 21.

Table 21: Baseline for industrial unit

Parameter	Units	Value	Comments
Baseline water consumption	m ³	63,576,633	Average of annual water consumption
Baseline annual production	MT	317,476	Average of actual annual production
Baseline specific water consumption	m ³ per MT	201.11	Average of annual specific water consumption

Next, on applying the steps for normalization discussed in Section 3.2 of the Handbook, the results are as presented in Table 22.

Table 22: Calculating normalization factor for industrial user

S.No.	Parameter	Units	Year 1	Year 2	Year 3	Comments
1	Capacity utilization	%	68	88	101	Computed
2	Specific water consumption	m ³ per MT	210.00	195.32	198.00	Computed
3	Max. annual capacity utilization threshold	%	90			Threshold defined by Implementing Agency
4	Min. annual capacity utilization threshold	%	70			Threshold defined by Implementing Agency
5	Is normalization required?		Yes	No	Yes	Based on whether (4) lies within the (6) and (7)
6	Impact of capacity utilization		0.64	-	3.52	Taking average normalization factor per percentage reduction in plant load = 0.32 m ³ per MT

Annexure 6: Illustrative Table of Contents of Water Audit Report

The contents of the audit report for the two major category of users – Industrial units and Urban Local Bodies – are discussed in Table 23.

Table 23: Illustrative Annotated Table of Contents of Water Audit Report

S.No.	Title	Description
1	Introduction	<p>This section will include the following:</p> <ul style="list-style-type: none"> • An overview of the Designated Water User • Scope of the water audit • Brief description on the methodology adopted for water audit
2	Geographical extent of user boundary	<p>This section will define the geographical extent of the boundary. This may be defined as per the type of water user. Examples of two types are elaborated:</p> <p>Case I: Industrial unit (Large industries, industrial parks, SEZs)</p> <ul style="list-style-type: none"> • The geographical boundary for industry shall be delineated on "Gate-to-Gate basis", including relevant water supply mechanisms, equipment consuming fresh water/ reused water, generating wastewater and water distribution system within the industrial unit. • The process flow diagram shall be created, dividing the process into unit operations. <p>Case II: Urban Local Bodies</p> <ul style="list-style-type: none"> • The geographical boundary shall be delineated based on the jurisdiction of ULB, and shall include the water sources, distribution network, delivery points to water users and return flow of waste or excess water.
3	Water Balance of the defined user boundary	<p>This section will be divided into three sub-sections :</p> <ul style="list-style-type: none"> • "Quantitative and Qualitative assessment of water inputs into the system". • "Determination of water leakages/losses" and • "Quantitative and Qualitative assessment of Wastewater outputs from the systems".



S.No.	Title	Description
3a	Quantitative and Qualitative assessment of water inputs into the system	<p>This sub-section will include assessment of quantity and quality of water inputs into the system. This assessment may be conducted as per the type of water user. Examples of two types are elaborated:</p> <p>Case I: Industrial unit (Large industries, industrial parks, SEZs)</p> <ul style="list-style-type: none"> All existing sources of water supply shall be identified. Annual water intake into the unit through data from the Water Storage tanks within the unit For metered usage, annual water consumption shall be recorded for each unit operation (e.g. Cleaning, Steaming, Cooling etc.) The accuracy of meters shall be checked, and volume will be corrected accordingly. For unmetered usage, the volume of annual water consumption shall be estimated based on information received from designated users/ existing literature/ comparable metered systems in similar industries/ water suppliers. The quantum of flow shall be verified through adequate sampling/ flow measurement program. The total annual water consumption (Q) of the industrial unit shall be estimated as the sum of metered and unmetered processes under each unit operation of the industrial plant. The quality of input water for each unit operation shall be in the industrial plant shall be monitored through triplicate grab sampling to assess the following parameters: pH, Chemical Oxygen Demand (COD), Biological Oxygen Demand (BOD), Total suspended solids (TSS), Total Dissolved Solids (TDS), oil and grease. <p>Case II: Urban Local Bodies</p> <ul style="list-style-type: none"> All existing sources of water supply shall be identified. Annual water intake into the water storage reservoirs (from water treatment plants or other sources) from where water is distributed to the households through the distribution network For metered usage, annual water consumption shall be checked through sample records of meter readings at the ULB for various consumer categories. The accuracy of sample meters shall also be checked. For unmetered usage, the volume of annual water consumption shall be estimated based on information received from designated users/ comparable metered systems/ existing literature/ water suppliers (s). Dependencies such as seasonal fluctuations in water consumption – hydroclimatic variables like temperature, precipitation, relative humidity, evaporative demand shall be factored in.





S.No.	Title	Description
		<ul style="list-style-type: none"> Total annual water consumption (Qi) in the urban local body shall be calculated as the sum of metered and unmetered water usage. The quality of input water in the ULB for all existing surface and ground water sources shall be monitored through triplicate grab sampling to assess following parameters: pH, Chemical Oxygen Demand (COD), Biological Oxygen Demand (BOD), Total suspended solids (TSS), Total Dissolved Solids (TDS), oil and grease.
3b	Determination of water leakages/losses	<p>This sub-section will assess the water losses at the various points within the defined user boundary. This assessment may be conducted as per the type of water user. Examples of two types are elaborated:</p> <p>Case I: Industrial unit (Large industries, industrial parks, SEZs)</p> <ul style="list-style-type: none"> Difference between the annual water intake into the unit and annual water consumption shall be assessed to identify the total system leakages Analysis will be performed to identify the level of water leakages from the system compared to the industry practices <p>Case II: Urban Local Bodies</p> <ul style="list-style-type: none"> Difference between the annual water intake into the water storage reservoirs (from water treatment plants or other sources) and total water consumption considering all consumers will constitute the total water leakages/loss at the distribution networks Analysis will be performed to identify the level of water leakages/losses through bifurcation of real loss (technical loss) and apparent loss (theft, faulty metering, unmetered customers etc.) compared to the best practices
3c	Quantitative and Qualitative assessment of Wastewater outputs from the systems	<p>This sub-section will include assessment of quantity and quality of wastewater outputs from the system. The assessment may be conducted as per the type of water user. Examples of two types are elaborated:</p> <p>Case I: Industrial unit (Large industries, industrial parks, SEZs)</p> <ul style="list-style-type: none"> The effluent discharge points, and location, size, and type of all discharge flows shall be identified. The site drainage network shall be characterised, identifying how flow from different unit operations or process areas contribute to the overall flow. The quantum of annual wastewater inflow into the ETP (or CETP) shall be ascertained. The accuracy of meters shall be checked, and volume will be corrected accordingly. The quantum of flows shall be verified through adequate sampling/ flow measurement program.



S.No.	Title	Description
		<ul style="list-style-type: none"> The quantum of expected effluent generation shall be estimated based on information received from designated users/ existing literature/ comparable metered systems in similar industries/ water supplier(s). If the difference between expected effluent generation and wastewater inflow into the ETP is beyond the pre-defined margin of error, it shall be estimated as the volume of untreated wastewater being discharged directly into the environment. The quantum of recycling/ reuse of wastewater (if any) shall be determined and further verified through appropriate sampling and flow measurement program. The quality of industrial effluent shall be assessed to determine its composition at ETP inflow, treated wastewater reused and treated wastewater discharged through suitable sampling methodology to assess the following parameters: pH, Chemical Oxygen Demand (COD), Biological Oxygen Demand (BOD), Total suspended solids (TSS), Total Dissolved Solids (TDS), oil and grease. <p>Case II: Urban Local Bodies</p> <ul style="list-style-type: none"> The wastewater discharge points, including location, size, and type of all discharge flows shall be identified. The catchment drainage network shall be characterised The volume of annual wastewater generated shall be ascertained. The accuracy of meters shall be checked, and volume will be corrected accordingly. The quantum of flows shall be verified through adequate sampling/ flow measurement program. The quantum of expected sewage generation shall be estimated based on information received from designated consumers/ comparable metered systems/ thumb rules such as interception factor. If the difference between expected sewage generation and sewage inflow into the STP is beyond the pre-defined margin of error, it shall be estimated as the volume of untreated wastewater being discharged directly into the environment. The quantum of recycling/ reuse of wastewater (if any) shall be determined and further verified through appropriate sampling and flow measurement program.





S.No.	Title	Description
		<ul style="list-style-type: none"> The quality of wastewater shall be assessed to determine its composition at STP inflow, treated wastewater reused and treated wastewater discharged through suitable sampling methodology to assess the following parameters: pH, Chemical Oxygen Demand (COD), Biological Oxygen Demand (BOD), Total Dissolved Solids (TDS), Total suspended solids (TSS), alkalinity, Nitrogen and Phosphorus.
4	Benchmarking with best practices	<p>This section will include benchmarking with best practices for the specific type of users. This assessment may be conducted as per the type of water user. Examples of two types are elaborated:</p> <p>Case I: Industrial unit (Large industries, industrial parks, SEZs)</p> <ul style="list-style-type: none"> The specific water consumption of the industrial unit shall be compared with similar industries. Best practices that may enable the industry to achieve global benchmarks shall be discussed. These may be global and regional best practices. <p>Case II: Urban Local Bodies</p> <ul style="list-style-type: none"> Best practices which may enable the ULB to minimise per capita freshwater consumption shall be discussed. These may be global and regional best practices.
5	Observations and Recommendations	<p>This section will include the following:</p> <ul style="list-style-type: none"> Summary of overall observations, results of the assessment and the auditor’s opinion along with the supporting documents shall be documented. Verification activities carried out in order to arrive at the conclusion, including the details captured during the verification process and conclusion relating to compliance with wastewater reuse norms, with reference to the baseline specific/ per capita freshwater consumption and baseline wastewater reuse shall be described. Interactions between the water auditor and the designated water user, the clarifications sought, and the revisions made in assessment because of the clarifications provided by the designated water user shall be recorded. Specific short-, medium-, and long-term measures to be proposed for reduction of specific water consumption, increase reuse of treated wastewater Financial analysis: Analysis of investments and payback period for those investments pertaining to reduction of specific water consumption, increase reuse of treated wastewater



Annexure 7: Overview of wastewater treatment technologies

Reclaimed water can be used for a variety of applications. Each application requires water quality standards for its use, and to achieve these standards, the respective Designated Water Users have to install specific technologies.

Annexure 7.1: Reclaimed Water Applications⁴²

Reclaimed water applications can be broadly classified into several types of uses. Table 24 provides the description of various water applications of reclaimed water

Table 24: Categorization of Water Reuse Application of Reclaimed Water

Category of Reuse		Description
Community Reuse	Unrestricted	The use of reclaimed water for non-potable applications where public access is not restricted
	Restricted	The use of reclaimed water for non-potable applications where public access is controlled or restricted by physical or institutional barriers, such as fencing, advisory signage, or temporal access restriction
Agricultural Reuse	Food Crops	The use of reclaimed water to irrigate food crops that are intended for human consumption
	Processed Food Crops and non-Food crops	The use of reclaimed water to irrigate crops that are either processed before human consumption or not consumed by humans
Impoundment and Recreational Reuse	Unrestricted	The use of reclaimed water in an impoundment in which no limitations are imposed on body-contact water recreation activities including snowmaking
	Restricted	The use of reclaimed water in an impoundment where body contact is restricted (may include fishing and boating)
Environmental Reuse		The use of reclaimed water to create, enhance, sustain, or augment water bodies, including wetlands, aquatic habitats, or stream flow
Industrial Reuse		The use of reclaimed water in industrial applications and facilities, power production, and extraction of fossil fuels
Ground Water Recharge – Non potable Reuse		The use of reclaimed water to recharge aquifers that are not used as a potable water source
Potable Reuse	Indirect Potable Reuse (IPR)	Augmentation of a drinking water source (surface or groundwater) with reclaimed water followed by an environmental buffer that precedes normal drinking water treatment
	Direct Potable Reuse (DPR)	The introduction of reclaimed water (with or without retention in an engineered storage buffer) directly into a water treatment plant, either collocated or remote from the advanced wastewater treatment system

42. Adapted from Guidelines for Water Reuse, United States Environment Protection Agency, 2012

Source: 'Guidelines for Water Reuse', United States Environment Protection Agency, 2012



Reclaimed water has several applications, as elaborated here.

Community Reuse: It includes various non-potable uses such as:

- Irrigation of public parks and recreation centers, athletic fields, school yards and playing fields, highway medians and shoulders, and landscaped areas surrounding public buildings and facilities
- Irrigation of landscaped areas surrounding houses, general wash down, and other maintenance activities
- Irrigation of landscaped areas surrounding commercial, office, and industrial developments
- Irrigation of golf courses
- Commercial uses such as vehicle washing facilities, laundry facilities, window washing, and mixing water for pesticides, herbicides, and liquid fertilizers
- Ornamental landscape uses and decorative water features, such as fountains, reflecting pools, and waterfalls
- Dust control and concrete production for construction projects
- Fire protection through reclaimed water fire hydrants

- Toilet and urinal flushing in commercial and industrial buildings

Community reuse can be further classified as "Restricted" or "Unrestricted" depending on public accessibility. Unrestricted reuse is the use of reclaimed water for non-potable applications where public access is not restricted. Restricted reuse is the use of reclaimed water for non-potable applications where public access is controlled or restricted by physical or institutional barriers, such as fencing, advisory signage, or temporal access restriction.

Agricultural Reuse: Agricultural reuse includes use of reclaimed water for irrigation. Irrigation uses huge amount of water and may contribute a significant fraction of a country water demand. For instance, in India, agriculture water constitutes 80–90% of total water demand. In such economies, use of reclaimed water can be an efficient tool for managing water resources, stemming from the need for a regulated supply that compensates for water shortages caused by seasonality or the irregular availability of other water sources for crop irrigation throughout the hydrological year.

Impoundment and Recreational Reuse: It uses reclaimed water for maintenance of impoundments range from water hazards on golf courses to full-scale development of water-based

recreational impoundments involving incidental contact (fishing and boating) and full body contact (swimming and wading).

It can be further classified as "Restricted" or "Unrestricted" depending on public accessibility. Unrestricted reuse is the use of reclaimed water in an impoundment of which no limitations are imposed on body contact water recreation activities. Restricted reuse is the use of reclaimed water in an impoundment where body contact is restricted for water recreation activities.

Environmental Reuse: It refers to the use of treated wastewater to create, enhance, restore, sustain, or augment water bodies including wetlands, aquatic habitats, or stream flow. The deliberate application of reclaimed water to wetlands can provide a beneficial use, and therefore reuse, by fulfilling any of the following objectives:

- To create, restore, and/or enhance wetlands systems
- To provide additional treatment of reclaimed water prior to discharge to a receiving water body
- To provide a wet weather disposal alternative for a water reuse system

Industrial Reuse: This includes use of reclaimed water in different industries say for Cooling

tower, Spray ponds, Boiler make up water, Industrial Process Water, and other uses (for ex. toilet flushing, gardening, washing etc.). The usage varies across different industries.

Groundwater Recharge – Non-potable Reuse: It is the use of reclaimed water to recharge aquifers that are not used as a potable water source. Groundwater recharge of reclaimed water can provide a number of other benefits including:

- Recovery of treated water for subsequent reuse or discharge
- Recharge of adjacent surface streams
- Seasonal storage of treated water beneath the site with seasonal recovery for agriculture



Potable Reuse: It is the use of reclaimed water for potable purposes either indirectly or indirectly. Indirect potable reuse (IPR) is the augmentation of a drinking water source (surface or groundwater) with reclaimed water followed by an environmental buffer that precedes normal drinking water treatment. Planned IPR involves a proactive decision by a utility to discharge or encourage discharge of reclaimed water into surface water or groundwater supplies for the specific purpose of augmenting the yield of the supply.

Direct potable reuse (DPR) is the introduction of reclaimed water (with or without retention in an engineered storage buffer) directly into a water treatment plant or into a municipal water supply distribution system. With rise in pollutants of concern in the environment which may eventually finds its way into wastewater treatment plants, use of reclaimed water for DPR is not recommended until further data is available and validated. So, use of reclaimed water for DPR is not discussed in the Handbook.



Annexure 7.2: Reclaimed Water Quality

Each of the water quality criteria (Grade A, B and C) consists of a set of commonly used parameters along with the limits. This includes pH, biochemical oxygen demand (BOD), chemical oxygen demand (COD) or total organic carbon (TOC), total suspended solids (TSS) turbidity, ammonia nitrogen (ammonia-N), total nitrogen (TN), total phosphorus (TP), fecal coliform, total dissolved solids (TDS), residual chlorine and other pollutants. Table 25 provides the water quality limit for these parameters for Grade A, B and C.

These recommended water quality grades are guidelines only and are not enforceable. These recommended values may be used directly or after modification by the regulatory agency to develop the permits for reuse. In such a situation, if a facility has existing permit with discharge standards, then stricter of the values provided in the permit and in Table 25 for all parameters must be followed. This will ensure that the facility is compliant with both the criteria and the discharge standard. Moreover, for Industrial wastewater, additional limits for metals, chemicals, organics and inorganics need to be added to Table 25 depending on the type and operation of industry.

Table 25: Water Quality Grade of Reclaimed Water for Reuse Application

Parameters	Unit	Grade C	Grade B	Grade A
pH	s.u	6.0 – 9.0	6.0 – 9.0	6.5 – 8.5
BOD	mg/L	≤ 30	≤ 10	--
Total Organic Carbon (TOC)	mg/L	--	--	≤ 2
TSS	mg/L	≤ 30	≤ 10	--
Turbidity	NTU	--	--	≤ 2
Ammonia-N	mg/L	≤ 1	≤ 1	≤ 0.5
Total Nitrogen (TN)	mg/L	≤ 10	≤ 10	≤ 3
Total Phosphorus (TP)	mg/L	≤ 1	≤ 1	≤ 0.5
Fecal Coliform	MPN/100 mL	≤ 200	Non-detect	Non-detect
Residual Chlorine	mg/L	≥ 1	≥ 1	≥ 1
Total Dissolved Solids (TDS)	mg/L	≤ 2,000	≤ 2,000	Drinking Water Standards
Aesthetics (color, odour etc)	As applicable	Agreeable	Agreeable	
Other Pollutants	As applicable	As applicable	As applicable	

Source: Adapted from 'Guidelines for Water Reuse', United States Environment Protection Agency, 2012



Different levels of treatment of wastewater are required to achieve different levels of water quality criteria. Table 26 provides the recommended basic water quality criteria for various categories of reuse. Limits for additional parameters may be added for any specific reuse. These guidelines apply to domestic wastewater from municipal or other wastewater treatment facilities having a limited input of industrial waste.

Direct Potable Reuse (DPR) of reclaimed water is not recommended as it may contain pollutants other than the pollutants shown in Table 25 which may pose health risk. Additional research is required to establish criteria for reclaimed water for DPR and be analysed on site-specific basis.

Table 26: Water Quality Grade of Reclaimed Water for various categories of reuse application

Category of Reuse		Reclaimed Water Quality Grade
Community Reuse	Unrestricted	Grade B
	Restricted	Grade C
Agricultural Reuse	Food Crops	Grade B
	Processed Food Crops and non-Food crops	Grade C
Impoundment and Recreational Reuse	Unrestricted	Grade B
	Restricted	Grade C
Environmental Reuse		Grade C
Industrial Reuse	Cooling	Grade C
	Other use	Depends on end use
Ground Water Recharge – Non potable Reuse		Grade C
Potable Reuse	Indirect Potable Reuse (IPR)	Grade A

Source: Adapted from 'Guidelines for Water Reuse', United States Environment Protection Agency, 2012

Annexure 7.3: Treatment Technologies

Industrial wastewater characteristics varies with the type and operation of the industry and so, treatment scheme will vary from facility to facility. On the other hand, domestic wastewater, unless mixed with industrial wastewater, is uniform and may be used as a benchmark. The treatment scheme of domestic wastewater will provide broad picture and the industries will be the same, with some changes depending on the type of industry.

Sewage Treatment Plant (STP)

The treatment units required for each of the three recommended treatment options – Treatment A, B and C – for domestic wastewater is elaborated in Table 27. STPs are designed to treat for BOD, COD, TSS, TN, NH3-N, TP, Fecal (or Total) coliform. Moreover, they are not designed to treat other pollutants such as TDS, hardness, metals and other organics and inorganics, although some of these pollutants may be removed incidentally. Additional treatment may be required to achieve limits for these other pollutants on a case-by-case basis, depending on the raw sewage quality and the quality of water required for the end-use.

Table 27: Treatment System for Achieving Different Water Quality Criteria of Reclaimed Water for Reuse Application

Treatment Units	Treatment C	Treatment B	Treatment A
Screen	✓	✓	✓
Grit Removal	✓	✓	✓
Primary Clarifier (Optional)	✓	✓	✓
Equalization (Optional)	✓	✓	✓
Advanced Biological Treatment	✓	✓	✓
Filter		✓	✓
Disinfection	✓	✓	✓
Sludge Treatment	✓	✓	✓
Additional Treatment	As required	As required	As required



Note that these three treatment options are only recommended options based on current industry practice. Installation of these treatment options do not guarantee that the water quality will be achieved. Also, these treatment options are in no way binding on the facility and the facility is free to choose any other treatment option to achieve

the water quality grades.

Moreover, as per the quality criteria discussed in Table 26 for different categories of reuse, the recommended level of treatment for each category of use is provided in Table 28.

Table 28: Level of treatment required for various categories of reuse application

Category of Reuse		Treatment Option
Community Reuse	Unrestricted	Treatment B
	Restricted	Treatment C
Agricultural Reuse	Food Crops	Treatment B
	Processed Food Crops and non-Food crops	Treatment C
Impoundment and Recreational Reuse	Unrestricted	Treatment B
	Restricted	Treatment C
Environmental Reuse		Treatment C
Industrial Reuse	Cooling	Treatment C
	Other use	Depends on end use
Ground Water Recharge – Non potable Reuse		Treatment C
Potable Reuse	Indirect Potable Reuse (IPR)	Treatment A

Grade B is the most common criteria used for recycling and reuse of reclaimed water. So, Treatment B represents the most common STP scheme for recycle and reuse of reclaimed water. Therefore, discussion will be focused on Treatment B. Treatment C is identical to Treatment B but with no filter. Treatment A is identical to

Treatment B with the following changes:

- Advanced biological system is designed to achieve TN of 3 mg/L
- Additional treatment that may be required to achieve Drinking Water Standards



A schematic of a typical STP is shown in Figure 46. This scheme represents "Treatment B" and will produce water quality Grade B and is described in detail below.

Figure 46: Schematic of STP for Grade B

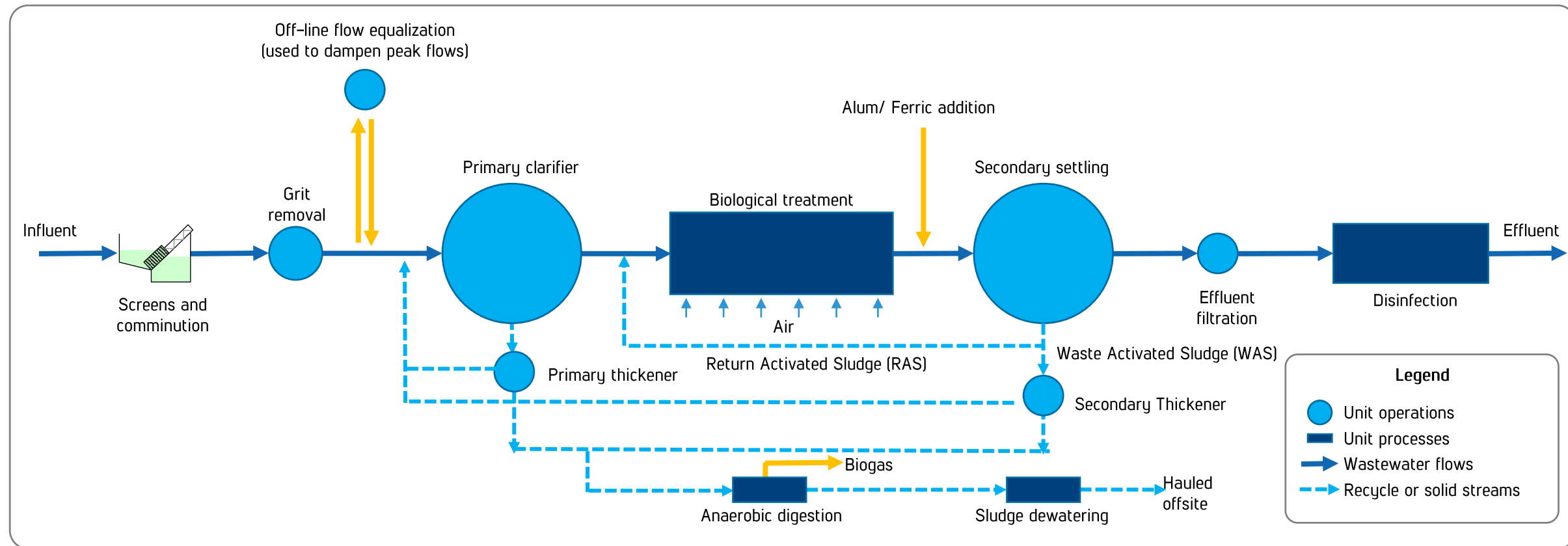



Raw domestic wastewater is first screened to remove rags, big particles etc. The screened wastewater then flows to grit chamber where grit, sand etc are removed. An equalization tank either on-line or off-line may be provided to ensure constant flow to the downstream process. The wastewater then flows to primary clarifiers where about 50–60% of the solids in wastewater are separated and sent to sludge treatment system. The wastewater then flows to the advanced biological treatment system consisting of biological tanks for removal of BOD, COD, TN and TP and secondary clarifier for removal of solids consisting of biomass and inerts. A portion of the solids that is separated is recycled to the biological tanks while the other portion is wasted and sent to sludge treatment system. Alum/ferric is added to wastewater before the secondary clarifier for removal of phosphorus chemically. The clarified wastewater then passes through a filter for further removal of solids. The filtered wastewater is then disinfected with chlorine (or ozone or ultraviolet rays) to kill the pathogens. The system assumes that influent TDS to STP will be $\leq 2,000$ mg/L and so no treatment of TDS is provided. Additional treatment for TDS reduction will be required if the influent TDS is $\geq 2,000$ mg/L. This treatment system meets the requirements for water quality Grade B.

Screening: Typically, screening is the first unit process used in the pre-treatment of domestic wastewater. A screen is a device with openings, generally of uniform size, that is used to remove coarse solids materials from the wastewater that could damage downstream process unit (and reduce overall process reliability and effectiveness) by interception (surface straining). Coarse solids include materials such as sticks, rags and other debris. Screens may consist of parallel bars, rods, or wires, grating, wire mesh or perforated plate and the openings may be of any shape but generally circular or rectangular slots. A screen composed of parallel bars or rods and is often called a “bar rack” or “bar screen” and is the most used variety.

Grit Removal: Grit chambers are located after the screens and are used to remove grit consisting of sand, gravel, cinders, and other heavy solid materials from domestic wastewater. Grit chambers are provided to (i) protect moving mechanical equipment from abrasion and accompanying abnormal wear, (ii) reduce formation of heavy deposits in pipelines, channels, and conduits and (iii) reduce digester cleaning. There three general types of grit chambers: (i) horizontal flow, (ii) aerated and (iii) vortex.

Equalization Unit: Daily flow and concentration of influent wastewater may vary. Equalization unit is required to dampen the variations and ensure nearly uniform hydraulic and organic loading to downstream process. This reduces cost of downstream process and improves reliability and performance. In STPs, equalization unit is generally used for equalization of flow. Depending on the characteristic of the collection system, some STPs may not even have equalization unit.

Primary Sedimentation: The objective of treatment by sedimentation is to remove readily settleable solids and floating material from the wastewater. Primary sedimentation is used as a preliminary step to remove suspended solids along with organics. Primary sedimentation can remove 50–60% TSS and 30–40% BOD. Detention time of primary sedimentation tanks vary between 1.5 – 2.5 hr. Circular clarifiers are usually used as primary sedimentation units. Chemicals such as alum polymers etc may be added to increase TSS and BOD removal. This is often done in Industrial Wastewater. In STPs, chemicals may be added to enhance phosphorus removal.

Biological Treatment: In a biological process, microbes (mainly bacteria) are cultured in tanks (called biological tanks) to remove the organic pollutants in the wastewater. Advanced biological process is removal of organics (BOD, COD) and nutrients (nitrogen, phosphorus) from wastewater.

Broadly, there are 5 types of biological treatment technologies as shown below

- i. Lagoons – aerobic, anaerobic, facultative
- ii. Activated sludge (ASP) variants⁴³
 - Complete Mix: Complete mix Activated Sludge (CMAS), two-sludge ASP, High purity oxygen ASP
 - Plug Flow: Conventional Activated Sludge (CAS), Step-feed, contact stabilization, two-sludge ASP, High purity oxygen ASP, Kraus process.
 - Extended Aeration: conventional extended aeration, oxidation ditch (OD), Orbal, Counter current aeration system (CCAS), Biolac.
 - Sequential Batch Reactor (SBR): conventional Sequential Batch Reactor (CSBR), intermittent cycle extended aeration system (ICEAS), Cyclic Activated Sludge (CAAS)
 - CMAS, CAS and SBR are the most used ASP technologies
- iii. Membrane Bioreactor (MBR)
- iv. Moving Bed Biofilm Reactor (MBBR)
- v. Integrated Fixed Film Activated Sludge (IFAS)

43. Adapted from Wastewater Engineering: Treatment and Reuse (Fourth Edition), Metcalf and Eddy, Inc., McGraw-Hill Companies, Inc.



Lagoons⁴⁴

Lagoons are pond-like bodies of water or basins with long detention time and are designed to receive, hold, and treat wastewater. They are the simplest and the least expensive treatment process. Lagoon system uses natural processes to provide low-cost wastewater treatment for many homes and rural communities. Lagoons are especially well suited to small communities because they cost less to construct and operate and are simpler to maintain than other systems. However, they require more land than other wastewater treatment methods.

Wastewater enters the lagoon where much of the

treatment occurs naturally, but some systems use aeration devices to add oxygen to the wastewater. Both biological treatment and settling of solids occur in the lagoons. Solids collected at the bottom of the lagoon are removed periodically. Lagoons are generally of 3 types: Aerobic, Facultative or Anaerobic.

Activated Sludge Process (ASP)

ASP is the most popular treatment technology used in the wastewater industry. Conventional or complete mix ASP are most used. A schematic of general ASP is shown in Figure 47.

Figure 47: Schematic of Activated Sludge Process (ASP)

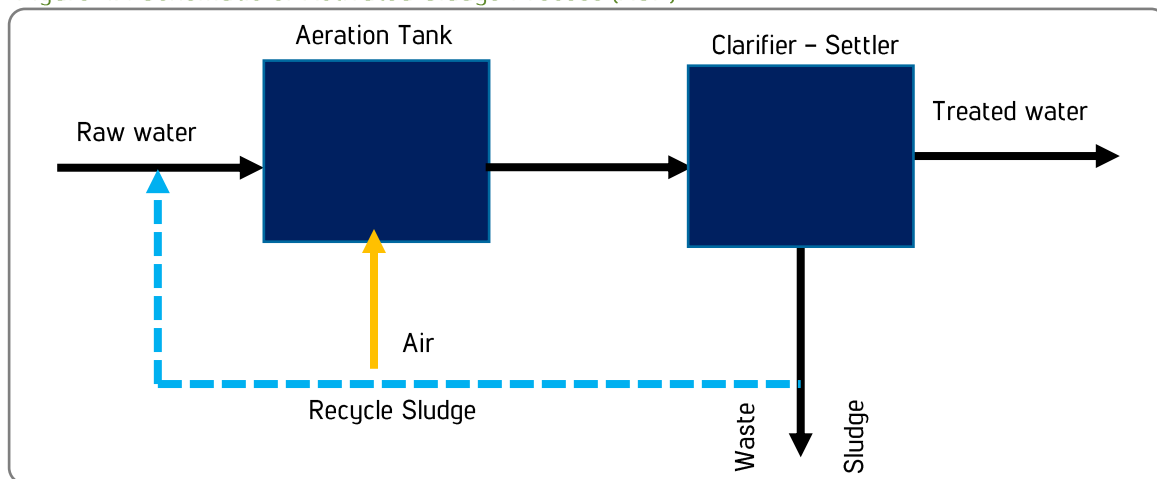

44. Catherine Taylor and Joseph Yahner, Agronomy [765] 494-4773. Don Jones, Agricultural Engineering [765] 494-1167. Purdue University and Alan Dunn, Indiana State Department of Health, accessed February 4, 2021. <https://engineering.purdue.edu/~frankenb/NU-prowd/lagoons.htm>

ASP consists of a biological tank containing microorganisms in suspended form and a clarifier. Wastewater from the primary clarifiers flows into biological tanks where organics are removed from wastewater by the microorganisms in the tank. Air is injected in the aerobic tank for carbon oxidation (oxidation of organics to carbon dioxide) by the microbes. Increasing the solids retention time (SRT) (time the microbes spend in the aerobic tank) of the aerobic reactor will also result in nitrification (converting nitrogenous organics to ammonia which are oxidized to nitrates). The wastewater then flows into the secondary clarifier where the biomass (microbes) is separated by gravity from the wastewater. A large portion of the biomass

that is separated is recycled to the biological tanks to maintain the microbe population in the tank while the other portion is wasted and sent to sludge treatment system. The clarified wastewater from the secondary clarifier overflows out.

Membrane Bioreactor (MBR)

A schematic of MBR is shown in Figure 48.

Figure 48: Schematic of Membrane Bioreactor (MBR) Technology

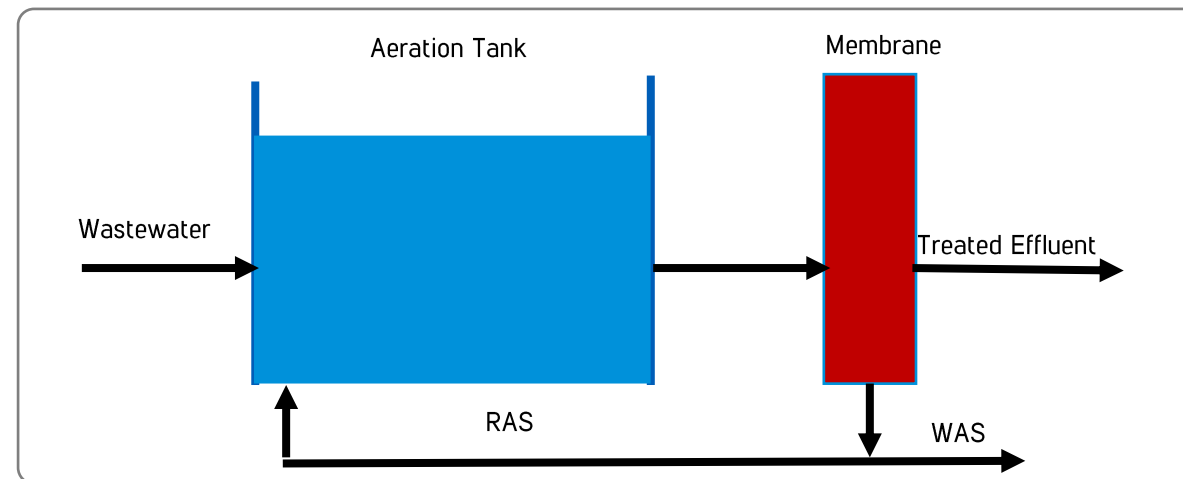

MBR process is identical to ASP process, with secondary clarifier replaced with membranes so that the solids are separated by the pores of the membrane instead of gravity. This enables MBR system to maintain higher biomass concentration in the aerobic reactor resulting in lower aeration tank volume.

Wastewater from the primary clarifiers flows into biological tanks where organics are removed from wastewater by the microorganisms in the tank. Air is injected in the aerobic tank for carbon oxidation by the microbes. Increasing the SRT of the aerobic reactor will also result in nitrification. The wastewater then flows into the tank with

membranes where the biomass (microbes) is separated from the wastewater. A large portion of the biomass that is separated is recycled to the biological tanks to maintain the microbe population in the tank while the other portion is wasted and sent to sludge treatment system. The clarified wastewater from the secondary clarifier overflows out. In some applications, the membranes are installed inside the aeration tank and no separate tank with membranes are required.

Moving Bed Biofilm Reactor (MBBR)

A schematic of MBBR is shown in Figure 49.

Figure 49: Schematic of Moving Bed Biofilm Reactor (MBBR) Technology

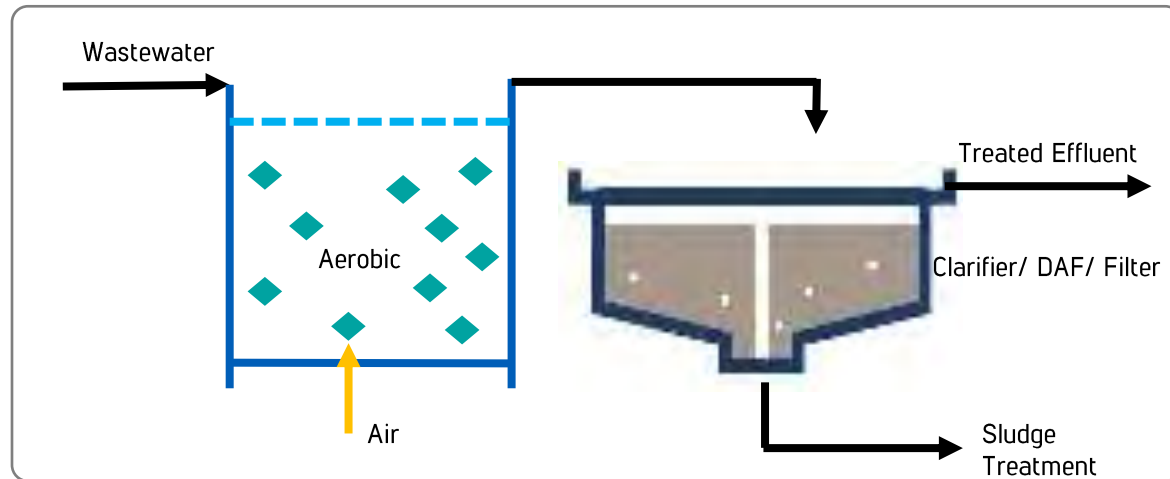

MBBR process consists of a MBBR (aerobic) tank containing plastic media and a clarifier. Unlike the ASP, the microorganisms grow attaching to the plastic media. Raw wastewater flows into biological tanks where organics are removed from wastewater by the microorganisms attached to the plastics in the tank. Air is injected in the aerobic tank for the carbon oxidation by the microbes. Additional separate MBBR tank(s) may be required for nitrification. The wastewater then flows into the secondary clarifier, dissolved air

flotation (DAF) or filter unit where the biomass (microbes) is separated from the wastewater. Unlike ASP, no recycle of the biomass is required. The clarified wastewater from the secondary clarifier overflows out. Tank volume required for MBBR process is significantly lower than ASP.

Integrated Fixed Film Activated Sludge (IFAS)

A schematic of IFAS is shown in Figure 50.

Figure 50: Schematic of Integrated Fixed Film Activated Sludge (IFAS) Technology

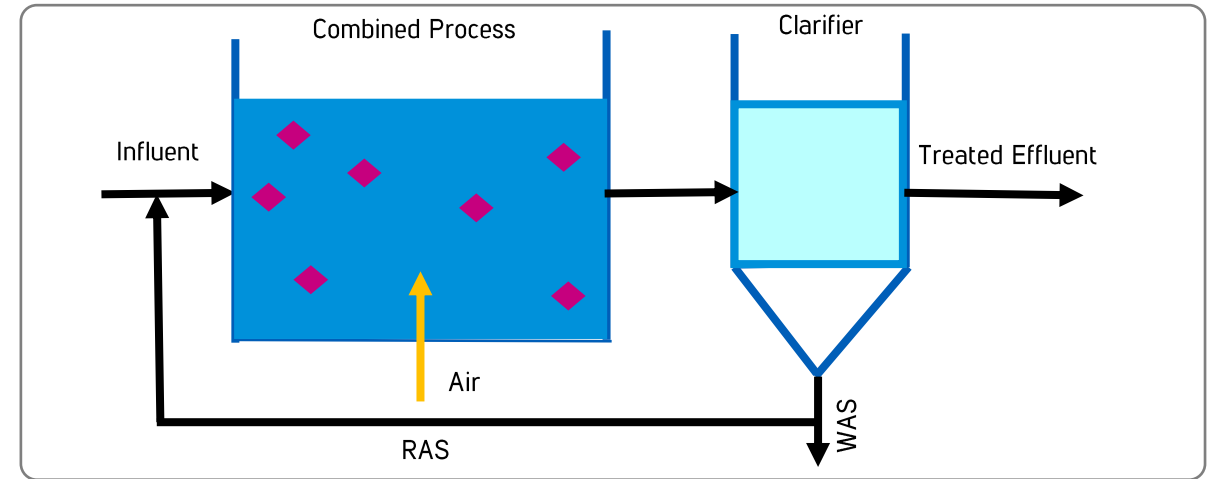



IFAS process is a combination of ASP and MBBR. It is identical to ASP with plastic media added to aeration (IFAS) tank. Like ASP, air is injected in to the IFAS tank where both carbon oxidation and nitrification occurs. Majority of the suspended microbes in the IFAS tank performs carbon oxidation and most of the microbes attached to the plastic media performs nitrification. This enables the process to perform both carbon oxidation and nitrification in the same tank resulting in lower tank volume compared to ASP.

Wastewater from the primary clarifiers flows into IFAS tanks where organics are removed from wastewater by the microorganisms in the tank. Air is injected in the IFAS tank for both carbon oxidation and nitrification by the microbes. The wastewater then flows into the secondary clarifier where the biomass (microbes) is separated by gravity from the wastewater. A large portion of the biomass that is separated is recycled to the biological tanks to maintain the microbe population in the tank while the other portion is wasted and sent to sludge treatment system. The clarified wastewater from the secondary clarifier overflows out.

Biological Nutrient (nitrogen and phosphorus) Removal technologies are discussed in subsequent sub-sections.

Filtration: Filtration is a tertiary treatment and is used as a polishing device to remove TSS (with consequent removal of insoluble BOD) before discharge. Typically, in wastewater treatment, filtration removes TSS from secondary clarifier effluent of 15–30 mg/L to less than 5 mg/L. A conventional filter consists of a cylindrical structure with a filter bed in it. The filter bed consists of sand (sand filtration) or other material. Disk filtration and cloth filtration are two other types of filter.

Disinfection: Disinfection is the process designed to kill or inactivate most microorganisms in wastewater, including essentially all pathogenic organisms. Pathogenic organisms can be bacteria, viruses, or cysts that can cause disease in a host. Chlorination, ozonation and UV are most common disinfection methods. In chlorination, chlorine or chlorine compounds is added to the wastewater in sufficient doses to kill the pathogens. Similarly, for ozonation, ozone generated at the site is injected in the wastewater. For UV disinfection, wastewater is passed through the UV bulbs to disinfect the wastewater.

Sludge Treatment and Disposal: Sludge treatment consists of collecting sludge from primary and secondary clarifiers, thickening, and then dewatering. Sludge dewatering is done by drying beds, filter press, centrifuge, or other dewatering equipment. Some large plants install anaerobic digesters after thickening reduce volatile solids in sludge and generate biogas which can be used to generate electricity or produce biofuel. Sludge produced from facilities having anaerobic digesters meets the Class B category of United States Environmental Protection Agency (EPA) Biosolids Rule. Additional treatment of sludge with Thermal Hydrolysis Process (THP) and other technologies produces Class A biosolids according to EPA Biosolids Rule. Class A biosolids are pathogen free and can be sold as fertilizer, soil

amendment or soil conditioner promoting circular economy.

When treated sludge is put to beneficial use it is called biosolids. Biosolids can be landfilled, incinerated or land applied. Land application is most environment friendly and promotes circular economy. Dewatered sludge with no treatment cannot be land applied. Only Class A can be land applied directly without restrictions. Class B can also be land applied but with restrictions.

Nutrient (Nitrogen and Phosphorus) Removal Technologies

Table 29 provides a list of technologies for nitrogen and phosphorus removal.

Table 29: Treatment Technologies for Nitrogen and Phosphorus Removal

Nutrient Removal:	Process	Configuration
Nitrogen Removal	Biological	Wuhrman Process, Ludzack-Ettinger Process, Modified Ludzack-Ettinger (MLE) Process, Four-Stage Bardenpho Process, Cyclical Nitrogen Removal (CNR) Process, SBR
	Physical/Chemical	Air/Ammonia Stripping, Ion Exchange, Breakpoint Chlorination
Phosphorus Removal	Biological	Phostrip Process, A/O Process, Modified Activated Sludge (MAS) Process, SBR
	Physical/Chemical	Chemical Precipitation (Chem P)



Typically, for combined nitrogen and phosphorus removal from wastewater, biological treatment is employed for nitrogen and BOD removal as it is cheaper and reliable. For phosphorus removal, chemical treatment or combined biological and chemical treatment is generally employed. Biological process is cheaper and chemical process is more reliable and ensures that the facility meets effluent phosphorus limits consistently. TSS is

removed either by clarifier or membrane. Table 30 provides commonly used technologies for combined nitrogen and phosphorus removal. These technologies can be employed in ASP, MBBR, IFAS or MBR mode.

Table 30: Biological Nutrient Removal Technologies for Combined Nitrogen and Phosphorus

Removal Technologies	Effluent TN (mg/L)	Effluent TP (mg/L)
Modified Ludzack-Ettinger + Chem P	10	1
Anaerobic/Anoxic/Oxic + Chem P	10	1
SBR + Chem P	10	1
4-stage Bardenpho + Chem P	3	1
5-stage Bardenpho + Chem P	3	1
SBR + Chem P	3	1



Modified Ludzack-Ettinger (MLE) Process

The MLE process is a two-stage nitrogen removal process where an anoxic tank (pre-anoxic) is placed before the aeration tank. It is the most commonly used configuration for biological nitrogen removal in domestic wastewater for achieving effluent TN = 10 mg/L. A schematic of MLE process in is provided in Figure 51.

Wastewater enters the anoxic tank where the nitrates recycled through nitrate recycle and the return activated sludge (RAS) is denitrified. The carbon source required for denitrification is provided by the organics in the wastewater. A significant amount of BOD is consumed during the process. The effluent from the anoxic tank then enters the aerobic tank where nitrification and removal of remaining BOD occur.

The nitrates formed from nitrification in the aerobic reactor are recycled to the upstream anoxic tank for denitrification through the nitrate recycle. The effluent wastewater from the aerobic reactor then flows into a clarifier where the biomass is separated from the wastewater. A portion of the biomass is recycled to anoxic reactor while the other portion is wasted as waste activated sludge (WAS) for further processing and eventual disposal. The treated wastewater from the clarifier then leaves the system for further treatment or disposal.

Figure 51: Modified Ludzack-Ettinger (MLE) Process

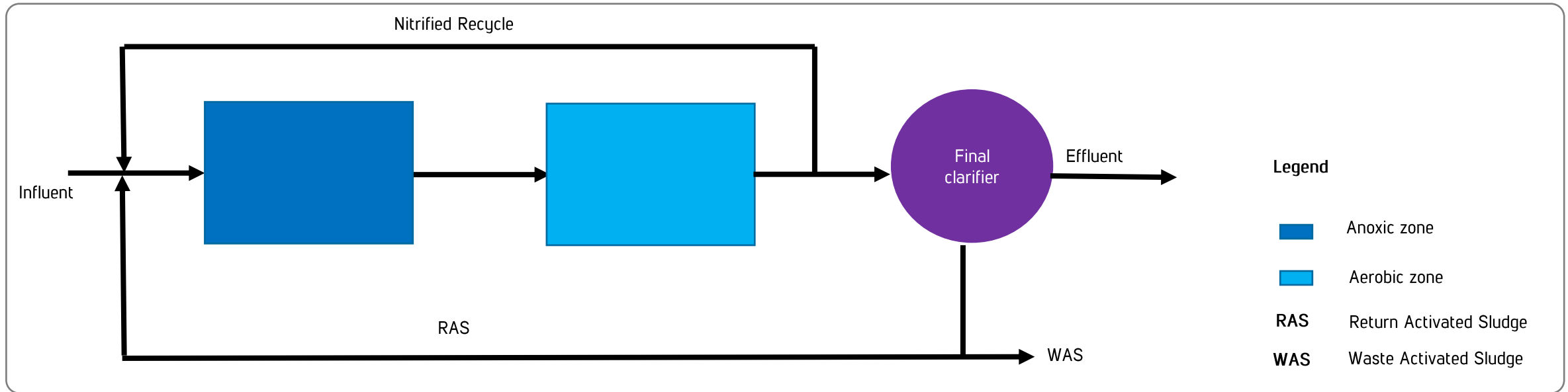

Anaerobic/Anoxic/Oxic (A2O) Process

The A2O (anaerobic/anoxic/oxic) process is a three-stage nitrogen and phosphorus removal process. The A2O process is a pre-denitrification process and is similar to MLE process with an anaerobic reactor installed ahead of the system. A schematic of the A2O process is shown in Figure 52. It consists of an anaerobic reactor followed by an anoxic reactor and an aerobic reactor. The anaerobic reactor is used for phosphorus removal.

Wastewater enters the anaerobic tank where release of phosphorus from the biocells occurs. In the process, a small amount of BOD is also consumed in the anaerobic reactor. Effluent from the anaerobic

tank then enters the anoxic tank where the nitrates recycled through nitrate recycle are denitrified with the consumption of a significant amount of BOD in the wastewater. The effluent from the anoxic tank then enters the aerobic tank where nitrification and removal of the remaining BOD occur. The nitrates formed due to nitrification in the aerobic reactor are recycled to the upstream anoxic tank for denitrification through nitrate recycle. In the aerobic tank, a significant uptake of phosphorus also occurs. The effluent wastewater from the aerobic reactor then flows into a clarifier where the biomass is separated from the wastewater. A portion of the biomass is recycled to anaerobic reactor while the other portion is wasted as WAS for further processing and eventual disposal. The treated wastewater from the clarifier then leaves the system for further treatment or disposal.

Figure 52: Anaerobic/Anoxic/Oxic (A2O) Process

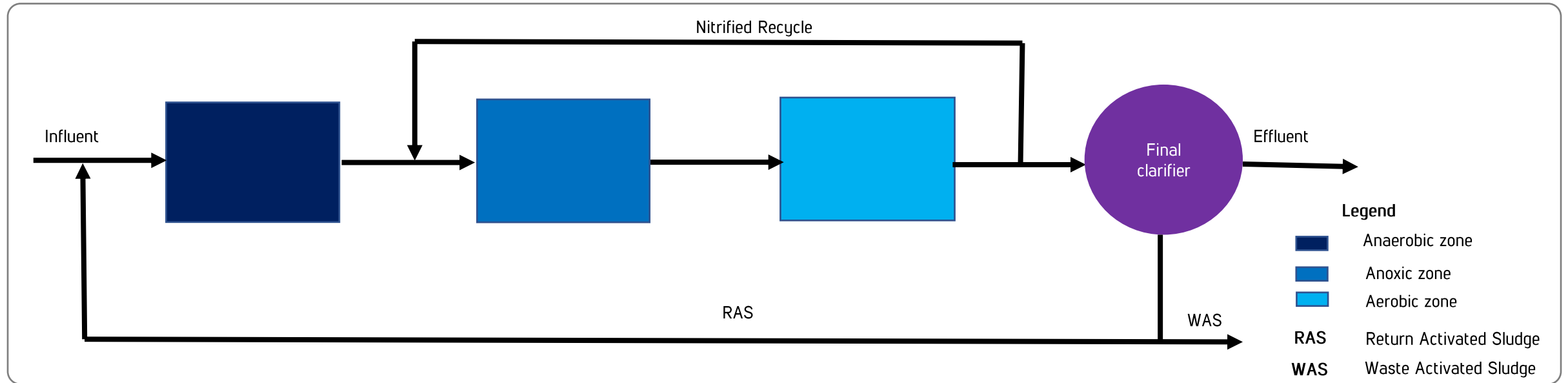

Four-Stage Bardenpho Process

The 4-stage Bardenpho process is a 4-stage nitrogen removal process to achieve low levels of effluent nitrogen. The process was developed by Barnard by adding two stages to MLE process, one anoxic (post-anoxic) and one aerobic (post-aerobic) stage. The added anoxic stage removes the remaining nitrates from the wastewater to achieve low effluent nitrogen concentrations. The added aerobic reactor polishes the effluent and strips gas from the sludge. A schematic of the 4-Stage Bardenpho process is shown in Figure 53.

Wastewater enters the first anoxic (pre-anoxic) tank where the nitrates recycled through nitrate recycle and RAS are denitrified with the consumption of a significant amount of BOD in the wastewater. The

effluent from the pre-anoxic tank then enters the first aerobic tank where nitrification and removal of BOD occur. The nitrates formed due to nitrification in the first aerobic reactor are recycled to the upstream pre-anoxic tank for denitrification through nitrate recycle. The effluent wastewater from the first aerobic tank then enters the second anoxic (post-anoxic) tank where further denitrification takes place. Because the upstream process units have removed most of the BOD in the wastewater, a supplemental carbon source is usually required for denitrification in the post-anoxic tank. The original Bardenpho process relied on endogenous decay as a carbon source for denitrification in post-anoxic reactor. The wastewater then enters the second aerobic reactor where the nitrogen gas formed by denitrification is stripped from the sludge and residual BOD is removed from the wastewater. Stripping is necessary for efficient settling of sludge in the clarifier. The effluent wastewater from the aerobic reactor then flows into the clarifier where the biomass is separated from the wastewater.

Figure 53: Four-Stage Bardenpho Process

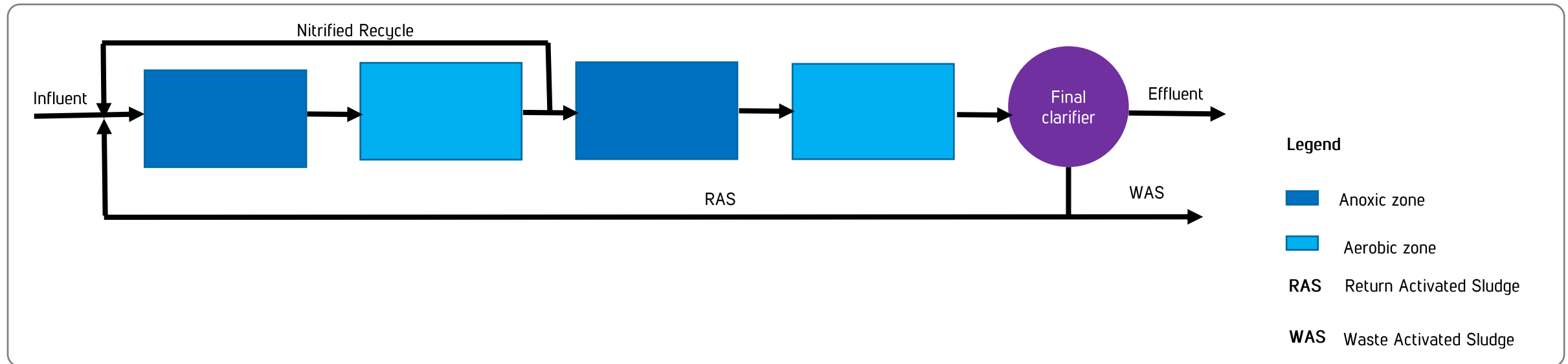

A portion of the biomass is recycled to the pre-anoxic reactor while the other portion is wasted as WAS for further processing and eventual disposal. The treated wastewater from the clarifier then leaves the system for further treatment or disposal.

Five-Stage Bardenpho Process

The five-stage Bardenpho process is a five-stage process to remove nitrogen and phosphorus. The process was developed by Barnard by adding an anaerobic stage at the head of the treatment train of the four-stage Bardenpho process. The anaerobic reactor is used for phosphorus removal. In scenarios that do not require phosphorus removal, the anaerobic reactor can be used as a selector for nitrification-denitrification process to suppress the growth of filamentous organisms. A schematic of the five-stage Bardenpho process is shown in Figure 54.

Wastewater enters the anaerobic tank where release of phosphorus from the biocells occurs. In the process, a small amount of BOD is also consumed in the anaerobic reactor. Effluent from the anaerobic tank then enters the first anoxic (pre-anoxic) tank where the nitrates recycled through nitrate recycle and RAS are denitrified. The organics in the wastewater provide the required carbon source for denitrification that results in a consumption of a significant amount of BOD. The effluent from the pre-anoxic tank then enters the first aerobic tank where nitrification and removal of BOD occur. The nitrates formed due to nitrification in the aerobic reactor are recycled upstream to the pre-anoxic tank for denitrification through nitrate recycle. In the aerobic tank, a significant uptake of phosphorus by biomass also occurs. The effluent wastewater from the first aerobic reactor then enters the second anoxic (post-anoxic) tank where further denitrification takes place. Because the upstream process units removed most of the BOD in the wastewater, a supplemental carbon source is usually required for denitrification in the second anoxic tank. The original Bardenpho process relied on endogenous decay as a carbon source for denitrification in post-anoxic reactor.

Figure 54: Five-Stage Bardenpho Process

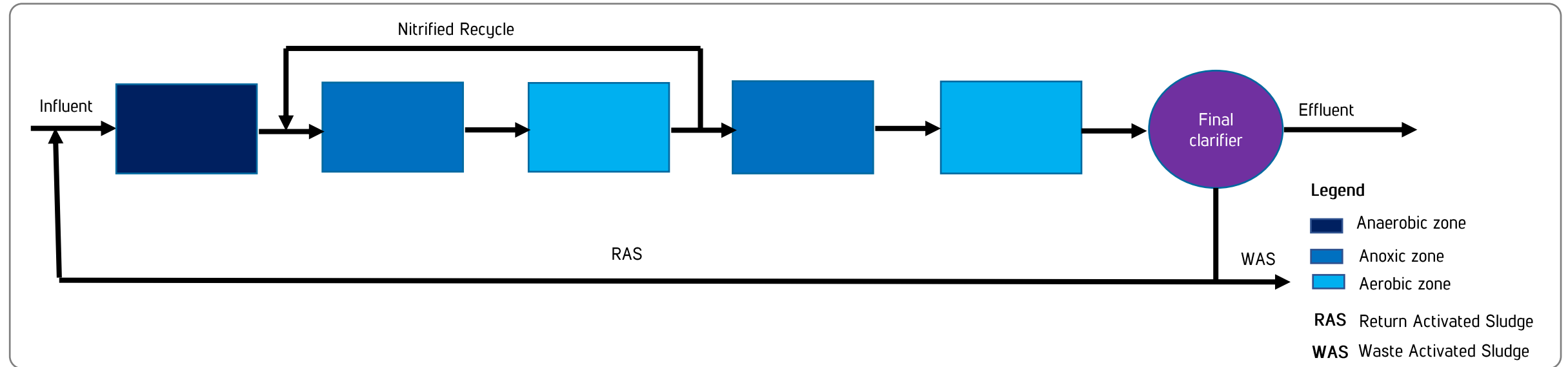

The effluent from the post-anoxic tank then enters the second aerobic reactor where the nitrogen gas formed by denitrification is stripped from the sludge and removes residual BOD in the wastewater. Stripping is necessary for efficient settling of sludge in the clarifier. The effluent wastewater from the aerobic reactor then flows into the clarifier where the biomass is separated from the wastewater. A portion of the biomass is recycled to the pre-anoxic reactor while the other portion is wasted as WAS for further processing and eventual disposal. The treated wastewater from the clarifier then leaves the system for further treatment or disposal.

Sequential Batch Reactor (SBR)

An SBR is a fill-and-draw, variable reactor volume technology. The SBR consists of a self-contained

treatment system incorporating anaerobic phase, anoxic phase, aerobic phase, and clarification within one basin. The tank is operated in cycles which usually lasts for 6 or 8 hrs resulting in 4 cycles/day or 3 cycles/day, respectively. Each cycle consists of a fill, react, settle, and draw phase with pre-determined time for each phase. Typical time for each phase for an 8-hour cycle is provided in Table 31.

Brief description of each phase is provided below:

- i. Fill: Consists of adding the wastewater with substrate for microbial activity, and usually includes mixing with no aeration thereby maintaining anaerobic and anoxic phase.
- ii. React: Air is turned on during react phase for BOD oxidation and nitrification.

- iii. Settle: The biosolids can settle. Liquid-solid separation occurs during the settle phase, analogous to the operation of a conventional final clarifier.
- iv. Draw: Clarified effluent is decanted; decanting can be achieved by floating or adjustable weirs. Waste activated sludge is wasted during this period at the same time.

The process flow for SBR technology is provided in Figure 55.

Figure 55: Phase-wise process of Sequential Batch Reactor technology

Chemical Precipitation for Phosphorus Removal (Chem P)

Chemical precipitation is a process where chemicals are added to react with dissolved ions in the wastewater to form insoluble solids which are then separated from wastewater by gravity. For phosphorus removal, metal salts such as ferric compounds (e.g., ferric chloride) or alum (aluminium sulphate) are usually added in the pipe (with or without an in-line mixer) or in a mix tank between the aeration basin and the secondary clarifier.

Table 31: Overview of SBR technology

Phase	Time (hours)	Mixing/ Aeration	Mode
Fill	2.0	Mixing	Anoxic/anaerobic
React	3.0	Aeration	Aerobic
Settle	1.0	None	Anoxic
Draw	2.0	None	Anoxic
Total	8.0		

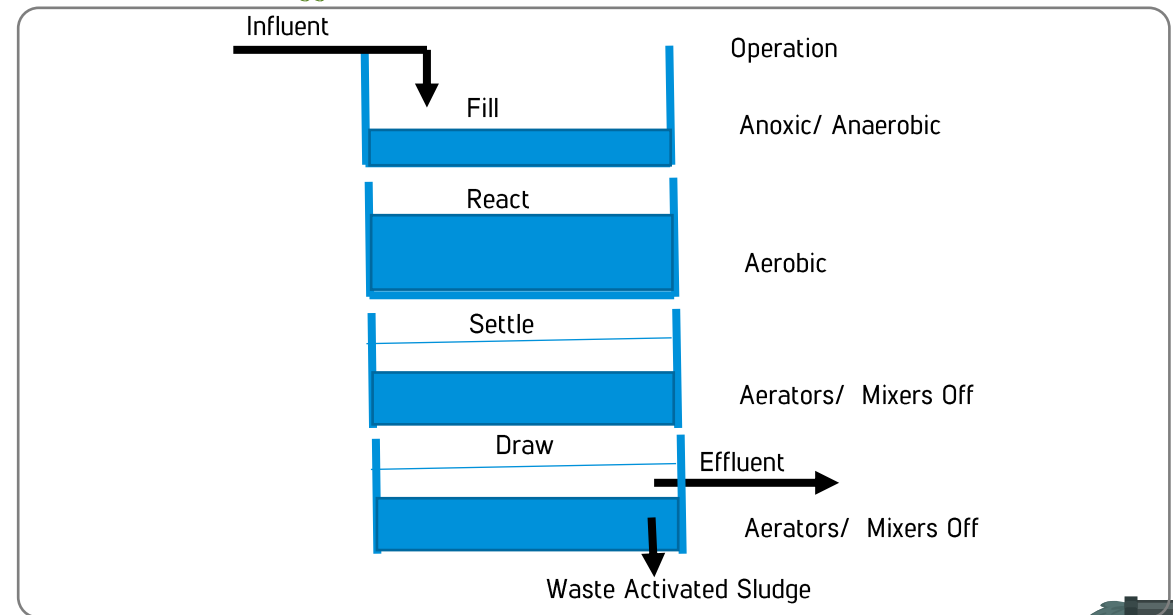



The metal salt added reacts with the phosphorus in wastewater to produce insoluble metal phosphates. This insoluble solids and other solid particles are then separated from the wastewater by gravity in the secondary clarifier. Polymers may also be added to aid in settling the insoluble particles in the secondary clarifiers.

Effluent Treatment Plant (ETP)

Industrial wastewater characteristics varies with the type and operation of the industry and so, treatment scheme will vary from facility to facility. However, most of the treatment technologies discussed above will be part of the basket of technologies for ETPs. Equalization, neutralization, oil and grease removal, metals precipitation, coagulation and flocculation, biological treatment, clarifiers and filters are some of the commonly used treatment units in ETPs.

- Equalization unit is considered an essential part of most ETPs in order to equalize the fluctuations in both flow and concentrations. Equalization unit may have retention time of few hours to several days depending on the

need and can be a tank or a lagoon.

- Neutralization tanks are used to neutralize the influent pH to the desired pH. Grease traps and flotation technology are used for removal of oil and grease.
- Metals precipitation is used to remove metals (mainly heavy metals) and coagulation and flocculation with clarifier are used to remove solids.
- Biological treatment is used to remove organics in wastewater. Filters are used as polishing units to remove TSS.
- Grit removal unit is not frequently present in ETPs.
- Sludge treatment consists of sludge dewatering with or without thickening.
- Dewatering is done by drying beds, filter press, centrifuge or other dewatering equipment.

The typical discharge limits for Industrial wastewater is shown in Table 32.

Table 32: Typical Discharge Limits of ETPs

Parameters	Unit	Grade C
pH	s.u	6.0 – 9.0
BOD	mg/L	≤ 30
COD	mg/L	≤ 250
TSS	mg/L	≤ 30

Examples of treatment technologies for various industrial wastewater achieving the discharge limits shown in Table 32 are presented in Table 33. Note that the characteristics of influent wastewater to ETP not only varies with Industry category but also may vary with sub-categories within a particular Industry. For example, textile

wastewater from one textile plant may be very different from another textile plant because of the difference in type of operation, process, product, and other factors. So, proper evaluation of wastewater characteristics and installation of right treatment units even within the same industry category is important.

Table 33: Popular Biological Nutrient Removal Technologies

Industry	Treatment Process
Textile	Screening, Equalization/Neutralization, Coagulation/Flocculation, DAF/Clarifier, ASP, Filter, ACF, sludge treatment
Pulp and Paper	Screening, Equalization/Neutralization, Coagulation-Flocculation, DAF/Clarification, ASP, Filter, ACF, sludge treatment
Tannery	Screening, FOG removal, Equalization/Neutralization, Coagulation/Flocculation; Sedimentation/Precipitation, ASP, Filter, ACF, sludge treatment
Pharma-Formulation Type	Screening, Equalization/Neutralization, Coagulation-Flocculation; Clarification, ASP, Filter, ACF, sludge treatment
Dairy	Screening, Equalization/Neutralization, Oil skimmer, ASP, sludge treatment
Cold Rolling Mill	Collection tank/equalization, skimmers, Coagulation-Flocculation; ASP, filter, ACF
Acid Pickling	Screening, Equalization/Neutralization, Coagulation-Flocculation; Filter, sludge treatment

Note: DAF = Dissolved Air Flotation; ASP = Activated Sludge Process; ACF = Activated Carbon Filter

The reuse of water involves treating wastewater to a quality acceptable for the intended reuse while posing the least risk to the user. Examples of industrial reuse include water required in irrigation and landscaping, washing, toilet flushing, cooling

tower, boilers, cement making, semi-conductor industry and all types of industries. All these reuse options require a specific water quality dictating the level of treatment necessary to achieve that quality.





Appropriate technologies are selected to treat waters to specific quality endpoints, and this is known as 'fit-for-purpose' (FFP) reuse.

For Industrial reuse, additional limits for metals and other chemicals may be imposed to meet the water quality required for the end-use. The quality of water required for various operations in different or even

the same industry will vary. Since there are numerous industries with different operations, the final quality of water and the treatment will vary widely based on the end use. For instance, water quality will be different for a cooling tower make-up water to that of boiler water make-up water or to those required for the semi-conductor industry. Requirement of water quality for boiler water is shown below. As can be seen that even for boiler water, the water quality required may vary with operating pressure.

Table 34: Required quality for boiler water

Drum Operating Pressure	0 – 300	301 – 450	451 – 600	601 – 750	751 – 900	901 – 1000	1001 – 1500	1501 – 2000	OTSG
Steam									
TDS max (ppm)	02 – 10	02 – 10	02 – 10	01 – 05	01 – 05	01 – 05	01	01	0.05
Boiler Water									
TDS max (ppm)	700 – 3500	600 – 3000	500 – 2500	200 – 1000	150 – 750	125 – 625	100	50	0.05
Alkaline max (ppm)	350	300	250	200	150	100	NA	NA	NA
TSS Max (ppm)	15	10	8	3	2	1	1	NA	NA
Conductivity max (µmho/cm)	1100 – 5400	900 – 4600	800 – 3800	300 – 1500	200 – 1200	200 – 1000	150	80	0.15 – 0.25
Silica max (ppm SiO ₂)	150	90	40	30	20	8	2	1	0.02
Feed water (Condensate and makeup, after deaerator)									
Dissolved Oxygen (ppm O ₂)	0.007	0.007	0.007	0.007	0.007	0.007	0.007	0.007	NA
Total Iron (ppm Fe)	0.1	0.05	0.03	0.025	0.02	0.02	0.01	0.01	0.01
Total copper (ppm Cu)	0.05	0.025	0.02	0.02	0.015	0.01	0.01	0.01	0.002
Total Hardness (ppm CaCO ₃)	0.3	0.3	0.2	0.2	0.1	0.05	ND	ND	ND
pH @ 25° C	8.3 – 10.0	8.3 – 10.0	8.3 – 10.0	8.3 – 10.0	8.3 – 10.0	8.8 – 9.6	8.8 – 9.6	8.8 – 9.6	NA
Non-volatile TOC (ppm C)	1	1	0.5	0.5	0.5	0.2	0.2	0.2	ND
Oily matter (ppm)	1	1	0.5	0.5	0.5	0.2	0.2	0.2	ND

Source: Boiler Water Quality Requirements and Associated Steam Quality for Industrial/ Commercial and Institutional Boilers (American Boiler Manufacturers Association, 2005)



Upgradation Required to meet Reuse Quality

Following upgrades are necessary to existing ETPs (which are meeting the current discharge limits shown in Table 32) to meet the water quality Grade A, B or C for reuse. Following additional units are required for upgrades if the existing plant does not have these units in-place.

- i** Biological Nitrogen Removal: Required only if the influent wastewater contains nitrogen at sufficient concentrations.
- ii** Phosphorus Removal: Required only if the influent wastewater contains phosphorus at sufficient concentrations.
- iii** Filter: Required to meet the effluent TSS concentrations for Grade A and Grade B. For ETPs treating complex industrial wastewater, it is recommended that filter be added even to achieve Grade C.
- iv** Disinfection: Required to meet the coliforms levels of Grade A, B and C.
- v** Ultra-filtration (UF) and Reverse Osmosis (RO): Required if the influent wastewater has a TDS concentration higher than 2,000 mg/L for Grade B & C and 500 mg/L for Grade A.
- vi** If RO is used then evaporator or solar pond may be required for reject management.
- vii** Activated Carbon: May be required as a polishing unit for wastewater that need to remove additional organics and COD.
- viii** Advanced Oxidation: May be required for wastewater that need to remove additional organics and COD.
- IX** Additional treatment to remove pollutants if the treated wastewater contains pollutants like metals, organics, and inorganics.



Membrane filtration may be used to remove TDS and other pollutants to produce a high-quality water for reuse. Besides, many local permits in some countries require that industrial wastewater achieve zero-liquid discharge and reuse the entire treated water. In such cases, Ultrafiltration (UF) and Reverse Osmosis (RO) units may be necessary. Evaporators or solar ponds are used to remove the rejects generated in RO process. A description of membrane filtration including UF and RO is provided below.

Figure 56: Membrane Filtration removal based on size

Membrane Filtration

Membrane filtration is the process of removing particles from water by passing the water through a porous membrane. It is used to remove the micron or sub-micron particles, depending on the pore size of the membrane used. UF and RO are the most used membranes used in wastewater treatment. Membrane Filtration removal based on size is as in Figure 56

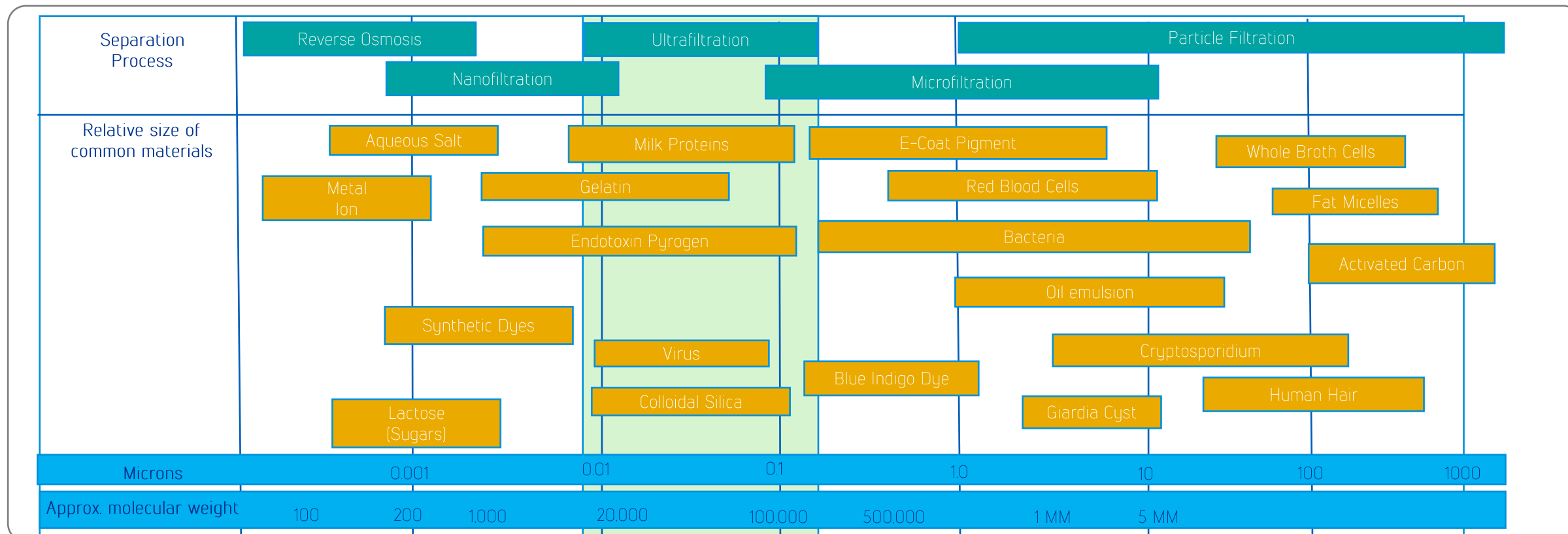

Source: 'Ultrafiltration, Nanofiltration and Reverse Osmosis', Website: <https://www.safewater.org/fact-sheets-1/2017/1/23/ultrafiltrationnanoandro>. Accessed on June 8th, 2021



The types of particles that are removed from the water with each type of membrane filter is summarized in Figure 57. In this diagram, the green arrow indicates that the particle is small enough to pass through the filter, whereas the deflected orange arrow indicates that the filter blocks the particle from passing through the filter.

Figure 57: Overview of membrane filtration

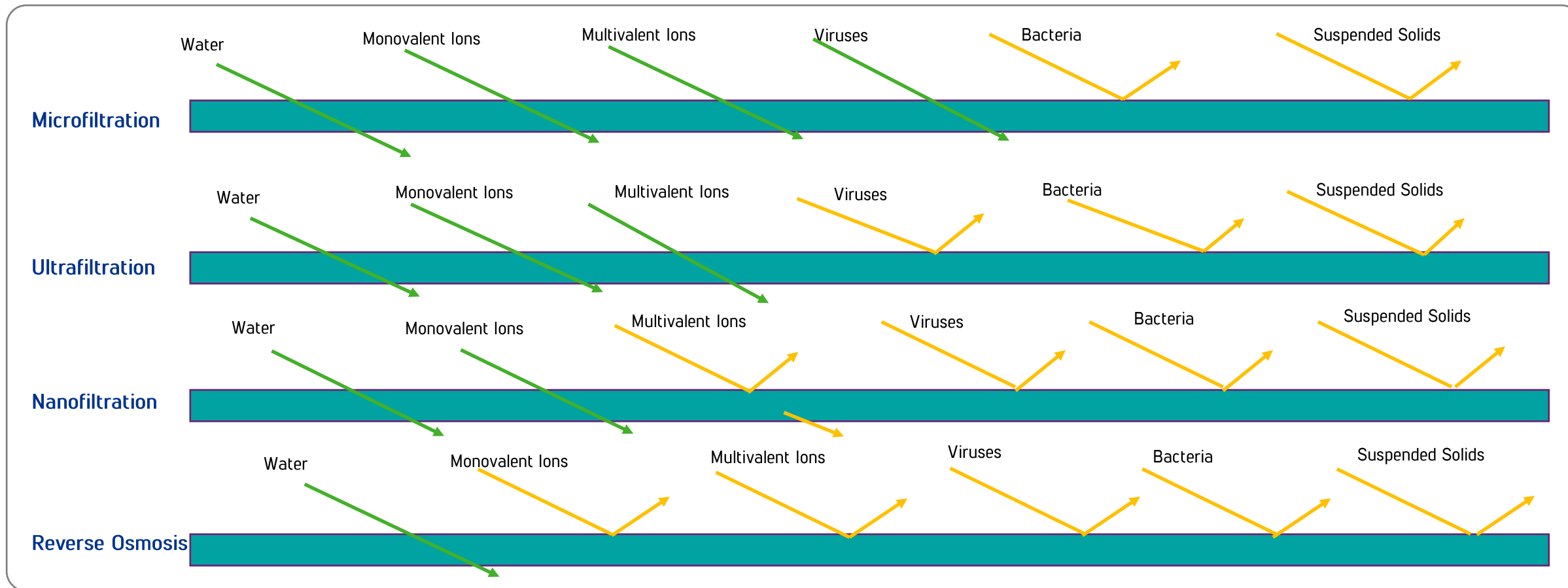

Source: 'Ultrafiltration, Nanofiltration and Reverse Osmosis', Website: <https://www.safewater.org/fact-sheets-1/2017/1/23/ultrafiltrationnanoandro>, Accessed on June 8th, 2021

Ultrafiltration (UF)

UF is a membrane filtration process used to remove essentially all colloidal particles greater than 0.01 to 10 microns size from water and some of the largest dissolved contaminants. The process uses hydrostatic pressure to force water through the semi-permeable UF membrane, which acts as a barrier.

The membrane removes suspended solids, bacteria, viruses, endotoxins, and other pathogens to produce water with very high purity. However, most of the dissolved ions and particles will pass through the membrane and will not be removed.

Reverse Osmosis (RO):

RO is a membrane filtration process used to remove particles greater than 0.0001 to 0.001 microns size from water. The process uses hydrostatic pressure to force water through the semi-permeable RO membrane, which acts as a barrier. The membrane removes dissolved ions, bacteria, virus, pathogens, and suspended particles. The product water is essentially pure water. The RO process is used to reduce TDS of the wastewater.



Annexure 8: Illustrative guidelines for efficient online monitoring

Transition towards self-regulatory mechanism for effluent monitoring is required to address rapid industrialization and the need for periodic monitoring to ensure treated industrial effluent is in accordance with the stipulated norms. In this regard, efforts are being made through technological interventions towards inculcating self-discipline amongst industries such that effluent data is continually transmitted to the concerned regulatory agency.

For instance, in India, most of the challenges faced during initial phases of implementation of such systems like technology selection, installation, calibration, and data transfer have been attended over the period and detailed guidance in this regard are published by Central Pollution Control Board, Government of India as 'Guidelines for Online Continuous Effluent Monitoring System (OCEMS)⁴⁵.

Key issues with real-time monitoring systems in India

The unsatisfactory experience with real-time monitoring systems in India may be attributed to inadequate operation and maintenance of the systems, leading to non-reliable/ non-existent database. Also, gaps in delineation of

responsibilities between industry and vendors have been observed. Further, support from vendor is also found to be inadequate in this regard.

Pre-requisites for efficient online analyzer

The online analyzer requires capability to operate unattended over prolonged period and withstand extreme environmental conditions; while producing accurate, precise, and analytically valid results. In addition, it should also have provision to record, validate, calibrate, transmit and interpret data on a real time basis. Minimal requirements for operation and maintenance along with low recurring cost of consumables and user-friendly maintenance shall further add to its acceptability.

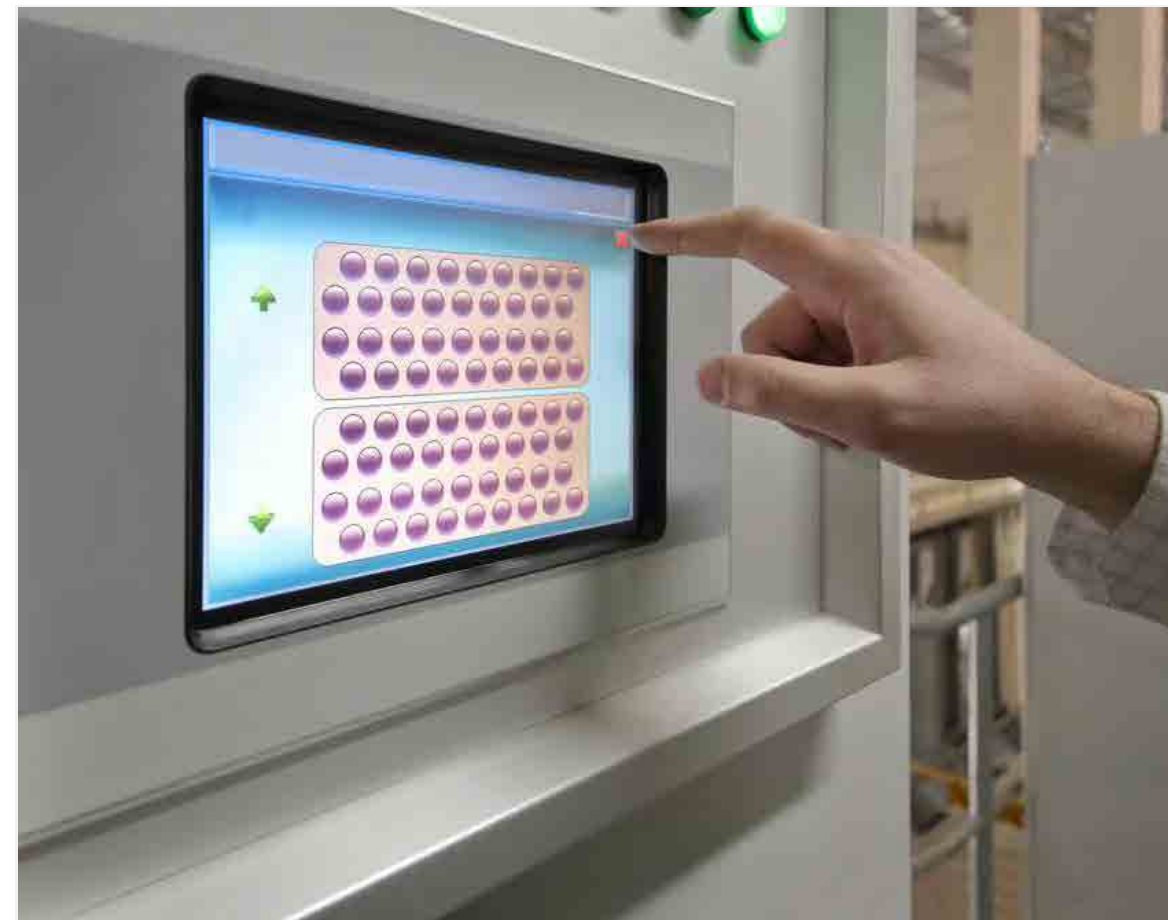

45. Guidelines for Online Continuous Effluent Monitoring Systems (OCEMS). 2018, accessed August 30, 2021. <http://www.indiaenvironmentportal.org.in/files/file/Revised%20Guidelines%20for%20Real-time%20Effluent%20Quality%20Monitoring%20System.pdf>.

Annexure 9: Illustrative example for issuance of WRCs

Here, we consider the volume equivalent of 1 WRC to be 1000 m³. Further, we consider a situation where the wastewater reused is of Grade C (or silver grade), where 1000 m³ of reused wastewater of Grade C is equivalent of 1 WRC. Further, a

negative value indicates the number of WRCs the user has to buy to meet its obligations under the WRC scheme.

Consider an industrial unit with the performance in the baseline year as indicated in the table below.

Table 35: Illustrative example with performance in baseline year

S.No.	Parameter	Value	Comments (if any)
1	Baseline production (tonnes)	31,694	
2	Baseline water withdrawal (m ³)	5,298,939	
3	Baseline wastewater generated (m ³)	3,236,022	
4	Baseline wastewater reused (m ³)	97,081	
5	Total water consumption (m ³)	5,396,020	Calculated as [2] + [4]
6	Baseline specific water consumption (m ³ per tonne)	170.25	Calculated as [5] / [2]
7	Baseline wastewater reused (%)	3%	Calculated as [4] / [3]
8	Reuse target set	33.09%	Based on target setting methodology

Scenario (a): In the assessment year, the production and the water use efficiency remain the same, and the user invests in reuse infrastructure (overachieving its target). The

performance in the assessment year and the relevant computations are indicated in Table 36.

Table 36: Illustrative example for issuance of WRCs – reuse measures

S.No.	Parameter	Value	Comments (if any)
1	Production (tonnes)	31,694	
2	Specific water consumption (m ³ per tonne)	170.25	
3	Total water consumption (m ³)	5,396,020	Calculated as [1] * [2]
4	Wastewater generated (m ³)	3,236,022	
5	Wastewater reused (m ³)	1,618,011	The user has invested in reuse infrastructure
6	Water withdrawal (m ³)	3,778,009	Calculated as [3] - [5]
7	Level of wastewater reuse achieved (%)	50%	Calculated as [5] / [4]
8	Number of WRCs issued	547	Based on the defined formula

Here, the user overachieves its target and is issued WRCs that it can sell during trading.

Scenario (b): In the assessment year, the production remains the same, the water use efficiency is enhanced, and the user invests in reuse infrastructure such that it reuses the same

quantum of wastewater as in Scenario (a). The performance in the assessment year and the relevant computations are indicated in Table 37.

Table 37: Illustrative example for issuance of WRCs – water efficiency measures

S.No.	Parameter	Value	Comments (if any)
1	Production (tonnes)	31,694	
2	Specific water consumption (m ³ per tonne)	150	The user has adopted water use efficiency measures in production.
3	Total water consumption (m ³)	4,754,100	Calculated as [1] * [2]
4	Wastewater generated (m ³)	2,851,059	
5	Wastewater reused (m ³)	1,618,011	Same as Scenario (a)
6	Water withdrawal (m ³)	3,136,089	Calculated as [3] - [5]
7	Level of wastewater reuse achieved (%)	57%	Calculated as [5] / [4]. The % reuse achieved is different from Scenario (a) due to adoption of water use efficiency measures.
8	Number of WRCs issued	766	Based on the defined formula

In Scenario (a) and Scenario (b), the user has invested the same amount invested in reuse infrastructure. However, in Scenario (b), the user has also adopted water use efficiency measures, resulting in reduced water consumption and wastewater generated. A reduction in wastewater generated results in an increase in the % reuse achieved (as percentage of wastewater generated).

Hence, the user is issued a greater number of WRCs in Scenario (b), than in Scenario (a). In fact, the user may consider investing in water use efficiency measures and still work towards achieving its reuse target. In this manner, both water reuse infrastructure and water use efficiency measures are incentivized to achieve the reuse targets.

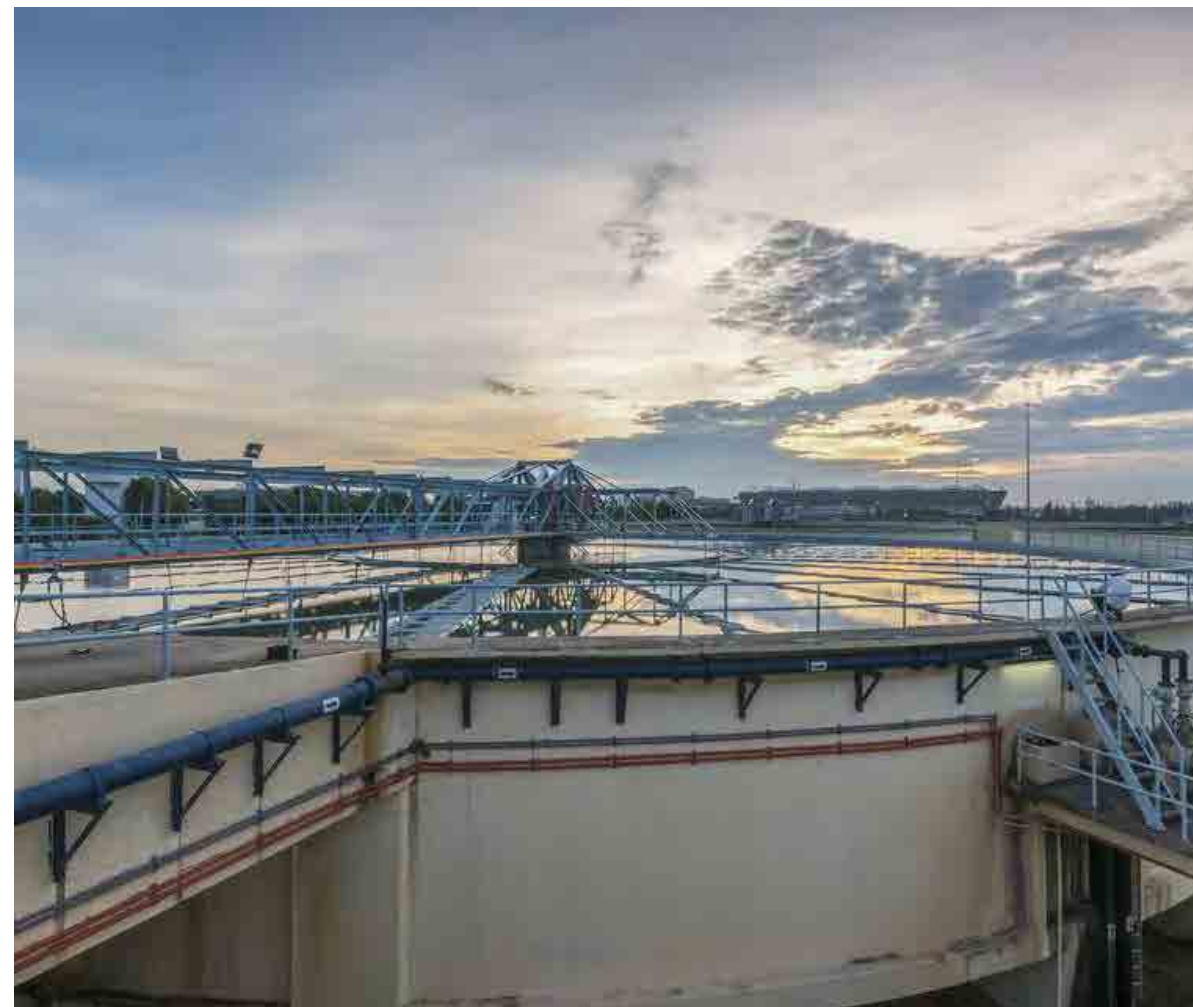

Annexure 10: Determination of prices of WRCs

Annexure 10.1: Determination of floor and ceiling prices of WRCs

Let us consider a market with four water users.

User	Cost of freshwater – C (\$ per kL)	Levelized cost of recycled water – L (\$ per kL)
User 1	0.47	0.20
User 2	0.53	0.29
User 3	0.60	0.27
User 4	0.67	0.13

The ceiling and floor prices are computed based on the formulae defined in Section 3.9, and the results

Table 39: Results for calculating ceiling and floor prices

Parameter	Value
Max value of C	0.67
Min value of C	0.47
Max value of L	0.29
Min value of L	0.13
Ceiling price of 1 WRC (i.e., 1000 m ³)	$= \max_n C_i - \min_n L_j = 0.67 * (103) - .13 * (103)$ $= \text{USD } 533.33$
Floor price of 1 WRC	$= \min_n C_i - \max_n L_j = 0.47 * (103) - 0.29 * (103)$ $= \text{USD } 173.33$

and the cost of water (C) and the levelized cost of recycled water (L) are as indicated in Table 38.

Table 38: Illustrative example for calculating ceiling and floor prices

Hence, trading between these 4 users will be in the range of USD 173.33 – USD 533.33. Consider

Table 40: Number of WRCs issued to users

User	Levelized cost of recycled water – L (\$ per kL)	# of WRCs issued	Comments
User 1	0.20	+ 300	Will sell if selling price is greater than \$200 (i.e., \$0.2 * 1000)
User 2	0.29	- 250	Will buy if buying price is less than \$290 (i.e., \$0.29 * 1000)
User 3	0.27	- 150	Will buy if buying price is less than \$270 (i.e., 0.27 * 1000).
User 4	0.13	+ 300	Will sell if selling price is greater than \$130 (i.e., 0.13 * 1000).

Hence, the trading between the four users will be governed by their individual economic rationales (as provided in Table 40 and within the limits defined by the floor and ceiling prices.

the market to be as indicated in Table 40.

Annexure 10.2: Reporting and Settlements of WRCs

The steps involved in reporting and settlements at the Trading Exchange are as follows:

- Bids are placed on the Trading Exchange:

- All Designated Water Users shall bid for buying/ selling of WRCs, as in Figure 58
- All Designated Water Users shall furnish deposits for trading in the bank account, confirming their margin requirement to the Exchange.

Figure 58: Batched bids for buying and selling WRCs

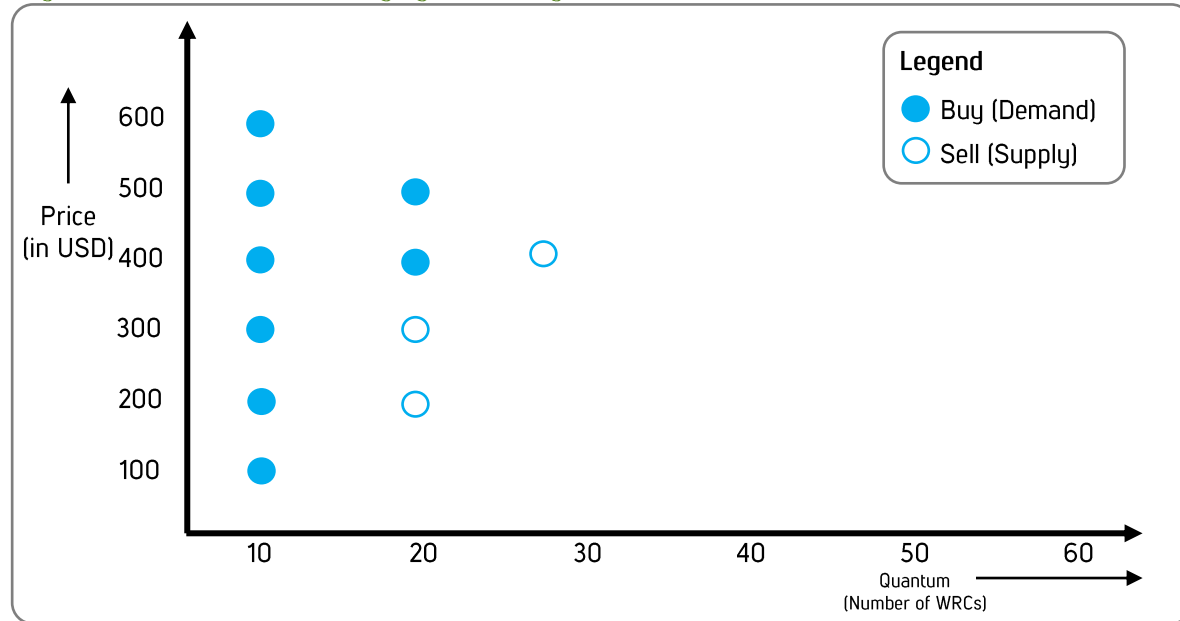

- Bids aggregation and determination of Market Clearing Price:
 - The buy and sell bids shall be further

aggregated, representing cumulated buy orders at the price or better and cumulative sell orders at the price or better, as in Figure 59.

Figure 59: Cumulated bids at the price or better for buying and selling WRCs

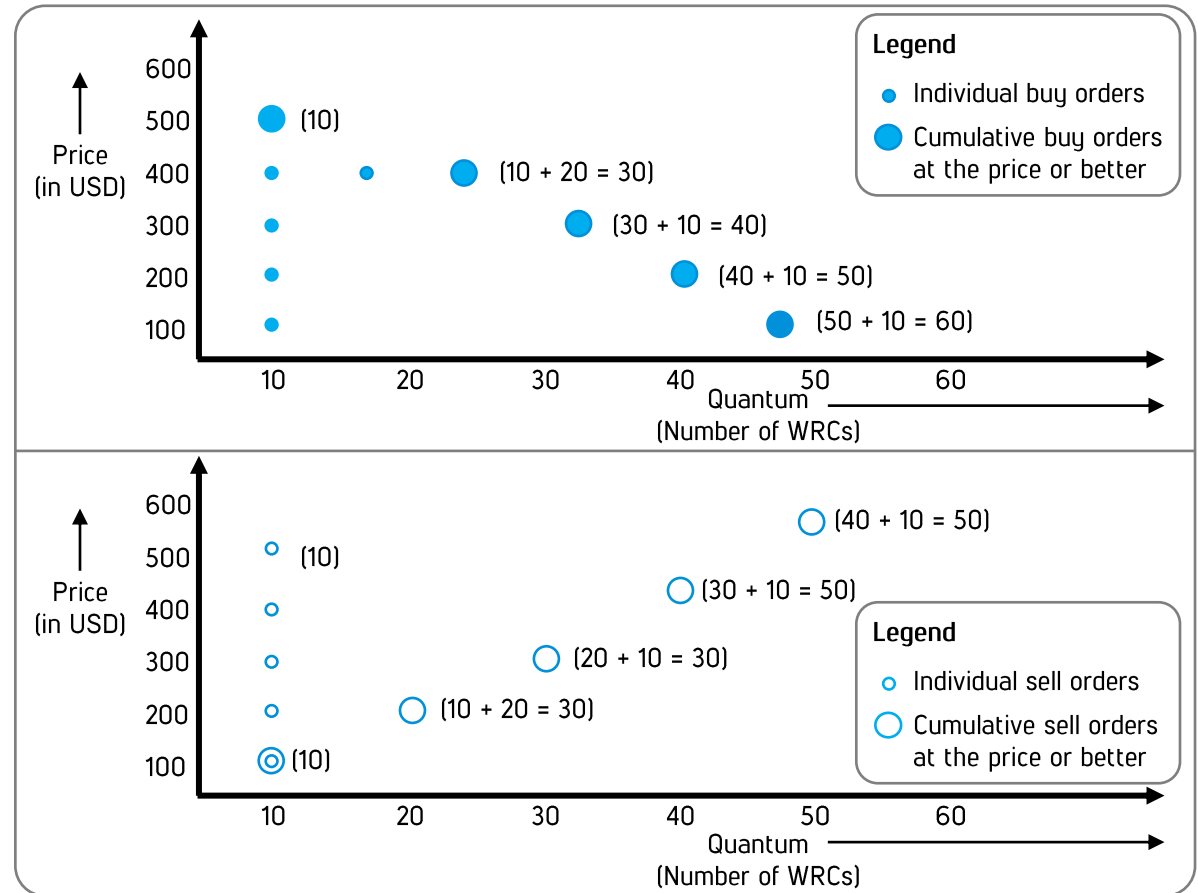

- The cumulated buy (Demand) and cumulated sell (Supply) orders shall be matched to obtain Market Clearing Price (MCP) and Market Clearing Volume (MCV) by the Trading Exchange. The equilibrium monetary value of traded WRC is determined by MCP i.e. 400 USD in Figure 60.

Figure 60: Market Clearing Price and Market Clearing Volume

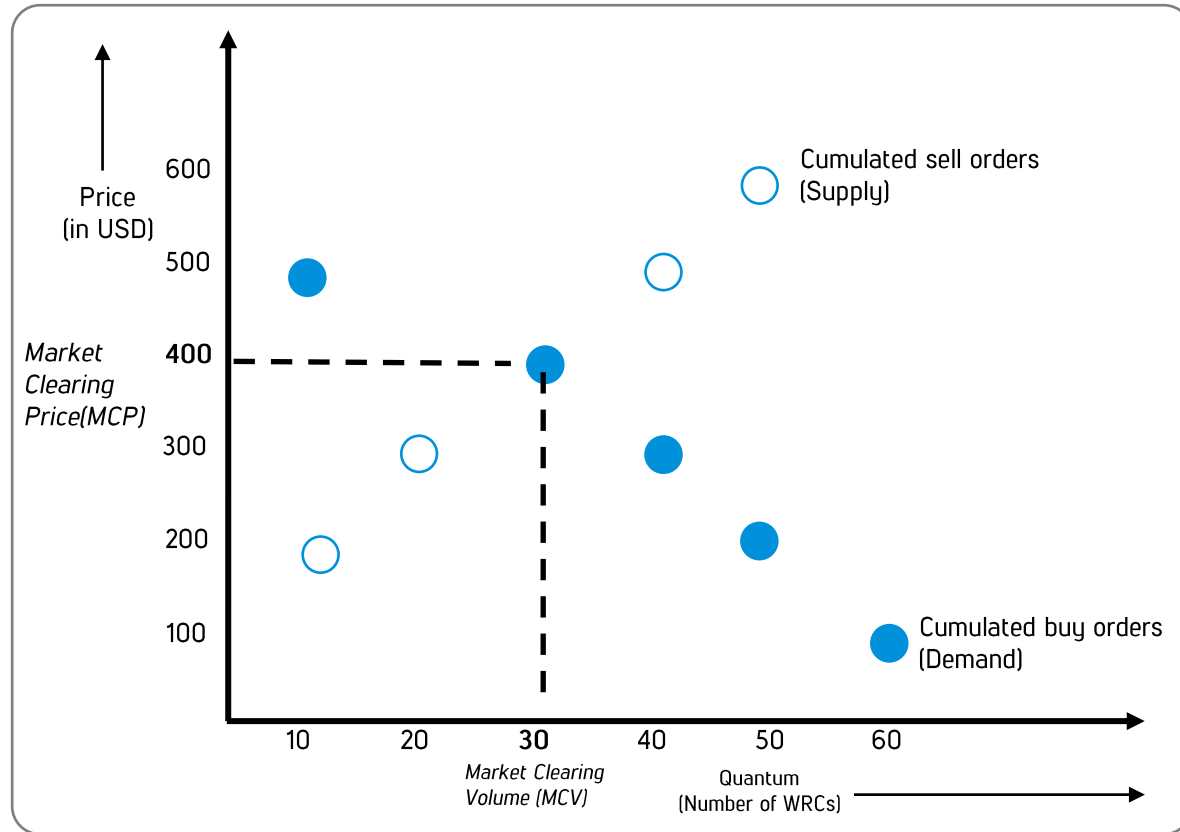

- Financial settlement of the transaction: On arriving at the MCP and MCV, the Trading Exchange will process the transaction. An invoice/ credit note shall be raised against the buyer's bank account and the financial settlement is made to the seller through its bank account, as depicted in Figure 61. This financial settlement may be undertaken through electronic banking.

Figure 61: Proposed mechanism for financial settlement of transaction

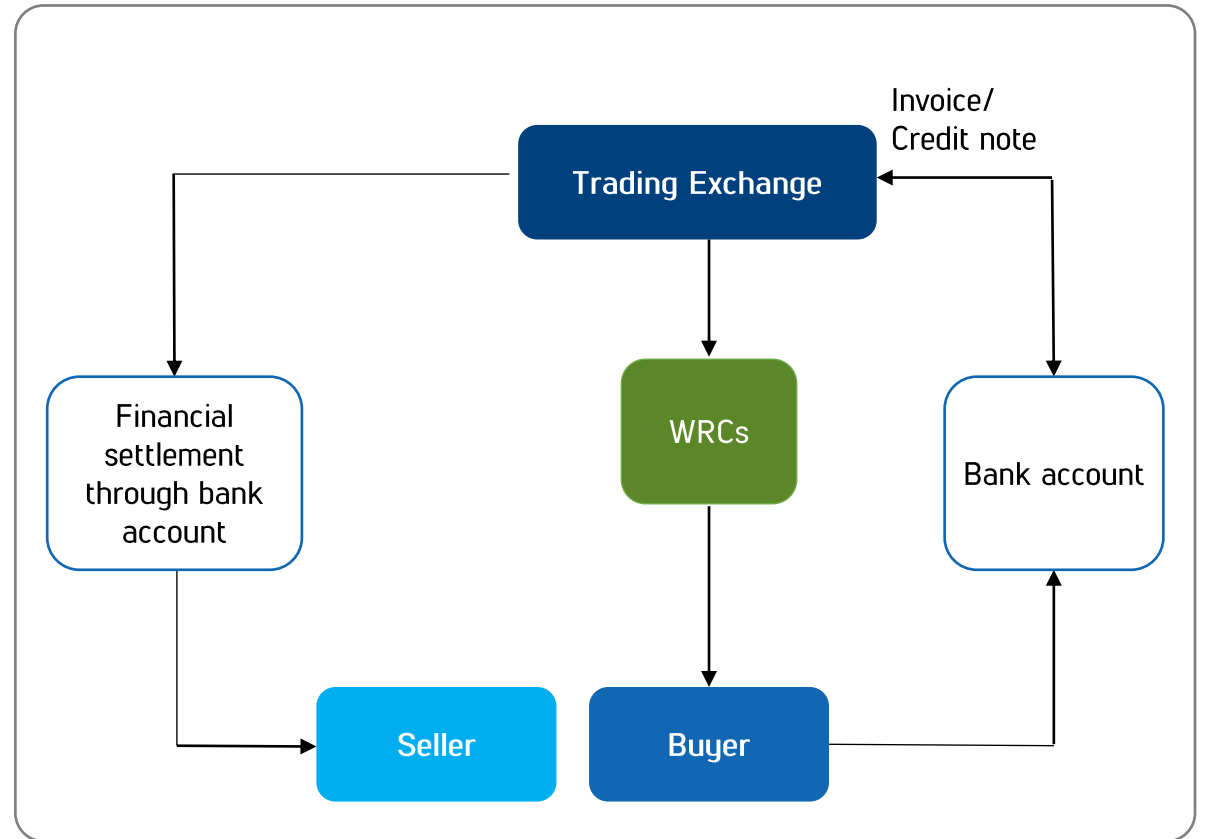

Annexure 11: Draft Model Guidelines for WRCs Issuance and Management

Background

This document provides regulatory framework for Obligatory Entities involved in the implementation of the Wastewater Reuse Certificate ("WRC" for short) mechanism as envisaged under [Name of Regulation] (hereinafter referred to as "WRC Regulations"). This procedure shall be called as 'Implementation Framework for WRC Issuance and Management' to be revised from time-to-time by the [Regulator] under specific revisions notified for public knowledge.

Wastewater reclamation is the process of converting wastewater into water that can be reused for beneficial purposes – such as agriculture, groundwater replenishment, industrial cooling, and industrial processes etc. Reclaimed water provides alternatives to freshwater sources and improves water security by narrowing the demand supply gap. Accordingly, the objective behind imposing the wastewater reuse obligation is to promote the use of reclaimed water and hence reduce the burden on freshwater resources.

WRC is a policy instrument to promote reuse of reclaimed water. It is a market-based mechanism which will help the Bulk Water Users to meet their regulatory requirements by overcoming the geographical constraints on the market for

reclaimed water. Some established means of financing reuse projects are project financing through state budgets for capital expenditure and tax on water use for operational expenses. Under the WRC mechanism, an alternative means of financing is envisaged by assigning a price on pollution or on the over-use of water sources.

Targets are assigned to the Obligatory Entities and those that exceed their respective targets shall be entitled to receive Wastewater Reuse Certificates (WRCs) with the equivalence of 1000 m³ reused wastewater ~ 1 WRC, as defined under the WRC Regulations. The figure below shows the trading mechanism for WRCs.

Structure of the WRCs trading mechanism

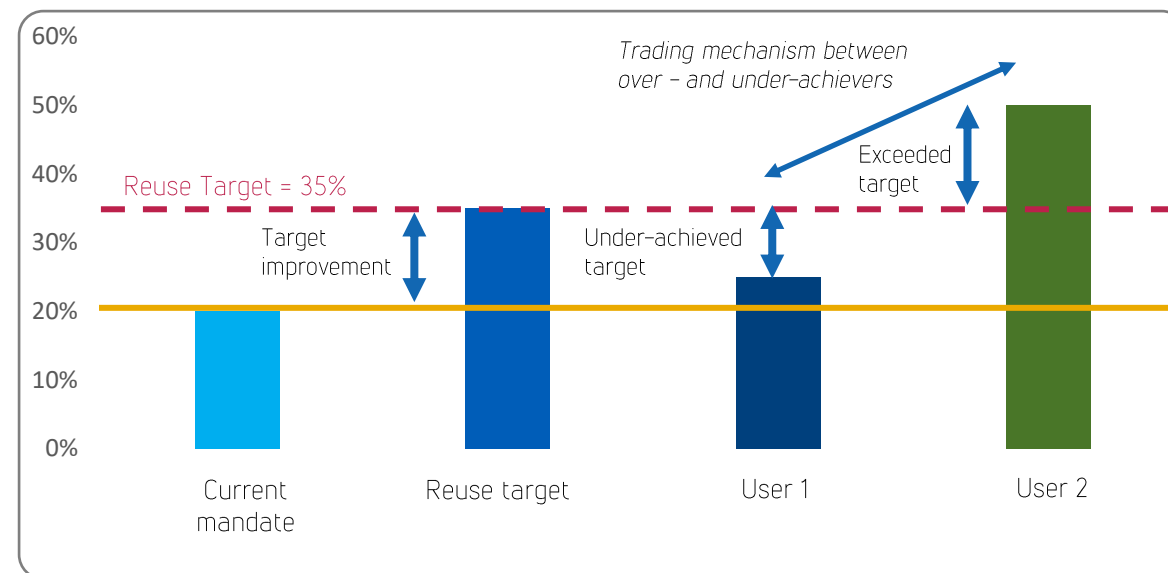

The WRC mechanism is in recognition of the polluters-pay principle and it provides polluters with the flexibility to adopt appropriate water pollution abatement measures to encourage cost-efficient pollution abatement, hence driving investments in innovative solutions and that

promotes technological advancements.

The steps to be followed to implement the WRCs (creating repository of WRCs and its trading) are described in the chart below and detailed in the subsequent sections of this document.

Steps to Implement WRC Program

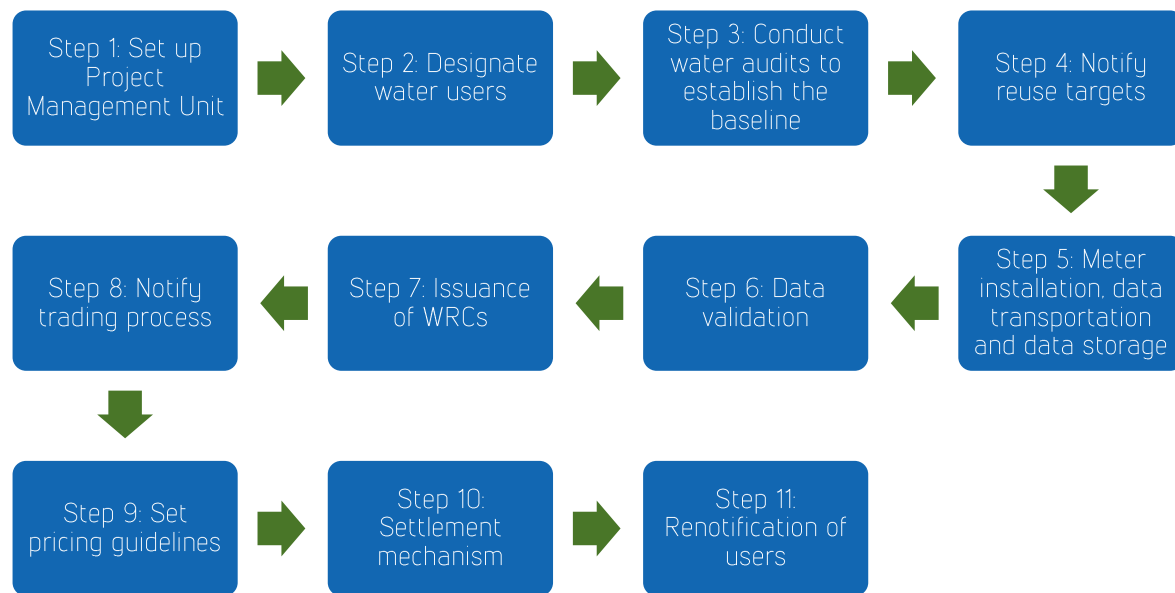

1. Applicability and Scope

1.1 The [Regulator] is the agency responsible for implementing the WRC initiative through its Program Management Unit. The [Regulator] is empowered to promote, regulate and monitor the use of reclaimed water and specify, from time to time, obligatory targets for use of reclaimed water in the form of percentage of total wastewater generated or

purchase of reclaimed water in the form of percentage of total consumption of water, and shall also address the mismatch between availability of reclaimed water and the requirements of obligated agencies by devising suitable mechanism.

1.2 This document shall apply to all Obligatory Entities.

2. Stepwise description of the Mechanism

2.1 Step 1: Set up Program Management Unit

2.1.1 The [Regulator] shall set up an independent Program Management Unit (PMU). The PMU will consist of an Advisory Committee, Technology Group, Market Monitoring Group (MMG) and Secretariat. The roles and responsibilities of the teams are listed below.

The independence of the PMU is to be maintained by the [Regulator] as the PMU is its own appointed group. The [Regulator] shall be responsible for selecting members and replacing those as may be necessary.

2.1.2 The object of the Advisory Committee shall be to advise the PMU on:

- a) Empaneling Water Auditors
- b) Developing methodology to establish the baseline
- c) Assigning reuse targets to Obligated Entities
- d) Setting technical standards for water meters and other hardware
- e) Appointing consultants to conduct economic and technical evaluations of the project

- f) Any other matters which the [Regulator] directs or PMU may put before it

The composition of the Advisory Committee is as follows:

- a) Committee to have 10 members.
- b) Chairperson of the [Regulator] shall be the ex-officio Chairperson of the Advisory Committee.
- c) PMU may appoint members after consultation with representatives of Obligatory Entities, wastewater technology service providers, any Special Purpose Vehicle (SPV) of the municipal bodies, or any Public Private Partnerships or Private entity engaged by the municipal bodies. Preference may be given to candidates with significant technical understanding of the water sector and wastewater treatment.
- d) The Secretary of the [Regulator] or any authorised person from among the staff of the [Regulator] shall be the Secretary of the Committee.
- e) Any member of the Committee may resign his office and it shall come into effect from the day the Chairperson of the [Regulator] accepts the same.



The Committee shall meet as follows:

- a) The Committee shall meet at least once every three months
- b) Tenure of Committee is 3 years and members are eligible for re-appointment
- c) Minutes of meetings to be made publicly available
- d) The quorum for a meeting of shall be four
- e) A member who fails to attend three consecutive meetings of the committee without prior intimation and without valid reasons for his/her absence shall cease to be a member of the Committee

2.13 The object of the Technology Group shall be to advise the PMU on:

- a) Selection of service provider for design of Information Technology aspects related to trading of WRCs including data acquisition, its safe storage and creation of immutable distributed ledger such as blockchain application
- b) Selection of open-source platform
- c) Security and encryption levels for data transfer
- d) Laying guidelines for secure data storage

- e) Empanelment of technology service providers
- f) Any other matters which PMU may put before it

The composition of the Technology Group is as follows:

- a) Shall include 5 members
- b) PMU may appoint members after consultation with regional industry bodies. Preference may be given to candidates with significant experience in designing and launching of remote data sensing and trading.
- c) Any member of the Committee may resign his office and it shall come into effect from the day the Chairperson of the [Regulator] accepts the same

The Technology Group shall meet as follows:

- a) Tenure of Technology Group is 3 years and members are eligible for re-appointment.
- b) A member who fails to attend three consecutive meetings of the Technology Group without prior intimation and without valid reasons for his/ her absence shall cease to be a member of the Technology Group.

2.14 The object of the Market Monitoring Group is to advise the PMU on:

- a) Selection of trading platform service provider ('Trading Exchange')
- b) Daily and routine tracking of metered data and tracking anomalies
- c) Reconciliation of data at the end of the year and bought/ sold WRCs
- d) Facilitating trading of WRCs
- e) Providing insights to the [Regulator] to set floor and ceiling prices of WRCs
- f) Any other matters which PMU may put before it

The composition of the Market Monitoring Group is as follows:

- a) Committee to have 5 members
- b) PMU may appoint members after consultation with other Government bodies conducting tradeable permit scheme. Preference may be given to candidates with experience in exchange trading, data security and management
- c) Any member of the Committee may resign his office and it shall come into effect from the day the Chairperson of the [Regulator] accepts the same

2.15 The object of the Secretariat is to:

- a) Publish notices on WRC
- b) Publish forms for registration, empanelment, certification etc
- c) Receive, scrutinise, and maintain documentation from participants, auditors, technology service providers
- d) Provide documentation on process of registration, registration of credits etc
- e) Carry out any other tasks that PMU may require it to do
- f) The Secretariat is to be staffed by 5 members of the staff of the [Regulator]

2.2 Step 2: Designate water users

2.21 The PMU shall acquire water consumption and wastewater generated data from bulk water consuming entities – municipalities and industrial consumers.

2.22 The PMU shall define the threshold limit for annual water consumption. Based on these threshold limits, the list of Obligatory Entities – including domestic and industrial bulk water users with annual water consumption greater than the threshold limit – will be finalized for the specific WRC trading cycle.





2.23 All municipalities and shortlisted industrial consumers are required to fill up the Application of Registration of WRC. In case the entity has multiple projects/ sites with wastewater treatment, separate applications will have to be submitted for each site, with each site considered as a separate entity/ WRC project. These applications are filled and processed on the WRCNet Portal, the web interface that is developed and hosted by the Administrator.

2.24 The Secretariat shall assign a unique acknowledgement number to the Applicant for each application for registration, for any future correspondence.

2.25 After receipt of application for registration, the Secretariat shall conduct a preliminary scrutiny to ensure that the Application Form is complete in all respects along with necessary documents and applicable processing fees and registration charges. The PMU shall undertake preliminary scrutiny of the Application within 2 working days from date of receipt of such Application.

2.26 After conducting the preliminary scrutiny, the Secretariat shall intimate in writing to the Applicant for submission of any further information, if necessary, to further consider the application for registration or reject the application. The reasons for rejecting the application for registration shall be recorded and intimated to the

Applicant in writing within 2 working days from date of receipt of the application by the PMU.

2.27 The Secretariat, after duly inspecting and verifying conditions elaborated above, shall grant 'Certificate of Registration' to the concerned Applicant. The process of registration shall normally be completed within 30 days from date of receipt of complete information by the Secretariat. In case registration is not granted at this stage, the reasons for rejecting the application for registration shall be recorded and intimated to Applicant in writing.

2.28 If registration is granted, the Secretariat shall intimate registration to the relevant entities.

2.3 Step 3: Conduct water audits to establish the baseline

2.31 The Advisory Committee shall empanel agencies to conduct water audits. The criteria for empaneling agencies shall be set in partnership with other competent entity with experience with setting up such empanelment at the regional level.

2.32 Baseline period to consist of past 3 years water consumption and wastewater treatment data, where available.

2.33 The Advisory Committee shall determine methodology to establish baseline, including normalization for capacity utilization, product mix and intermediary product, fuel quality, raw material

quality, addition of new line/ unit and other external factors.

2.34 The Advisory Committee shall set range of costs of water audit, by type of participant.

2.35 WRC participants shall select and appoint an empaneled agency to establish the baseline. The cost is to be borne by the participant.

2.36 A third-party empaneled agency shall verify the baseline, paid for by the PMU.

2.37 In case of any inconsistency between the water audit report and the verification report, the [Regulator] will impose a penalty on the respective participant based on pre-defined rules and procedures.

2.38 The findings of the water audit and verification shall be made public to ensure transparency.

2.4 Step 4: Notify reuse targets

2.41 The [Regulator] shall notify the target for use of reclaimed water as percentage of total wastewater generated. Such reuse targets shall be reviewed after period not less than three years.

2.42 The Advisory Committee shall determine methodology for estimating technical, economic, and achievable potential of water reuse among project participants, based on factors including baseline data, technology employed, water purchased, wastewater discharged and current

technology available.

2.43 Over successive phases of the WRC trading, the [Regulator] shall consistently increase the reuse targets, thereby reducing total pollution and achieve the set long-term targets.

2.5 Step 5: Meter installation, data transportation and data storage

2.51 The Advisory Committee shall set standards for water meters, in consultation with empaneled water auditors and experts in the field. Meters are required to measure quantity and quality of treated and untreated wastewater and record and send data every hour with relevant data encryption protocols.

2.52 Meters shall be tested at inlet and discharge points of municipal wastewater plants and industrial plants, and at the inlet of each activity utilizing treated wastewater. After testing, a list of selected meters is to be made available for Obligatory Entities to choose.

2.53 The Technology Group shall partner with members of relevant industry associations shall develop standards for the following aspects of data transportation from meters to central data warehouse: design of application and selection of open-source platform, security, and encryption levels, making data tamper-proof, transparency of data ledgers, service providers- availability, cost.



2.5.4 Based on established criteria, the data transportation system shall be tested at municipal wastewater plants and industrial discharge points. After testing, central data warehouse shall be set up to receive data and allow data verification.

2.6 Step 6: Data validation

2.6.1 Data testing shall be conducted at all participant sites to check for anomalous readings.

2.6.2 The [Regulator] will develop rules of thumb for specific water consumption, specific wastewater generation, among others, based on consultations with industry stakeholders, process experts and academicians.

2.6.3 Results of data tests shall be examined by third party consultants and areas of failure shall be identified and rectified.

2.6.4 To enhance data security, third parties shall be assigned to verify tamper proof ledger entries.

2.7 Step 7: Issuance of WRCs

2.7.1 The [Regulator] shall assess the performance of each user based on the real-time data monitoring, the data validation algorithms, the water audit reports and the verification reports. The [Regulator] shall define procedures for issuance of WRCs to each participant as per the quality and quantity of treated wastewater reused by the respective participant.

2.7.2 The WRCs shall be issued and held by the respective participants in electronic form.

2.7.3 Three levels of WRCs shall be issued as per the following criteria:

Quantum of reclaimed wastewater	Quality of reclaimed wastewater	Level	Number of WRCs issued
1000 m ³	Grade A	Platinum	2
1000 m ³	Grade B	Gold	1.5
1000 m ³	Grade C	Silver	1

Here, Grade A is of the most stringent quality while Grade C is the least stringent.

2.7.4 The quality standards for Platinum, Gold and Silver shall be determined by the Advisory Committee and are subject to annual review. At this stage, Grades A, B and C correspond to recycled water quality pertaining to boiler-feedwater standards, cooling water intake standards and agriculture use standards respectively.

2.7.5 All WRCs shall be pooled into a single exchange.

2.8 Step 8: Notify trading process

2.8.1 The Market Monitoring Group shall lay down requirements for a trading platform. Bid announcement for experienced trading platforms to set up a trading platform shall be published by the Secretariat. After scrutiny of bids and selection, service provider shall be appointed.

2.8.2 The Market Monitoring Group shall publish guidelines on data access, security, and storage by trading platform.

2.8.3 The Market Monitoring Group shall put procedure in place to monitor encryption, check for data anomalies and inform the Advisory Committee in case of non-compliance.

2.8.4 During the specified time limit, the participants who are short of their respective

target shall buy the WRCs at the market price and comply with the regulatory obligations and submit the compliance of the same to the Market Monitoring Group.

2.8.5 At the end of each year, the Market Monitoring Group shall reconcile data, including WRCs allotted, bought, and sold by each participant, and accordingly report the number of WRCs with each participant.

2.9 Step 9: Set pricing guidelines

2.9.1 WRC prices will be set by market forces, based on demand and supply for WRCs.

2.9.2 The price of WRCs shall be determined through double-sided closed auction. Market Clearing Price shall be calculated at the end of the bidding session with pre-announced method such as double-sided auction with uniform pricing principle.

2.9.3 The Market Monitoring Group will define the methodology for determining the floor and ceiling price during a trading cycle and the WRCs shall be traded among the participants within these bounds.

2.9.4 The floor and ceiling prices shall be periodically estimated, reviewed, and revised, depending on the observations and evaluations of trading in previous trading cycles.





2.10 Step 10: Settlement Mechanism

2.10.1 For each trading session, the Trading Exchange shall be empowered to discover a Market Clearing Price and a Market Clearing Volume.

2.10.2 All participants shall provide bank account information and furnish deposits for trading. Financial settlement shall be carried out through electronic banking.

2.10.3 WRCs shall be transferred to the buyer in electronic form.

2.10.4 Secretariat shall record transactions and notify participants that have not met targets or purchased WRCs at the end of the year.

2.11 Step 11: Renotification of users

2.11.1 After the completion of the trading period, or a specified number of years, an evaluation of the scheme shall be undertaken.

2.11.2 Based on the result of the evaluation, the Advisory Committee shall study the potential for including new consumer categories including housing societies, large agricultural properties in WRC trading scheme.

3. Dispute Resolution

3.1 The [Regulator] shall set up dispute resolution procedures to settle disputes related to the WRC scheme.

3.2 The Regulator shall constitute an independent Dispute Resolution Committee, which allows for objective and transparent resolution of disputes in the implementation of the WRC scheme. The object of the Dispute Resolution Committee is to resolve disputes regarding registration of applications, establishing the baseline, target setting, water audit, trading.

3.3 The composition of the Dispute Resolution Committee is as follows:

- a) Dispute Resolution Committee to have 3 members.
- b) Quorum for conducting meetings shall be 2.
- c) The [Regulator] may appoint members after consultation with other Government regulatory bodies. Preference may be given to candidates with legal experience.
- d) Any member of the Dispute Resolution Committee may resign his office and it shall come into effect from the day the Chairperson of the [Regulator] accepts the same.

3.4 All disputes to be resolved within 21 days unless any justification is offered on want of additional information.

4. Reporting Requirements

4.1 Reporting requirements of Obligatory Entities include:

- a) Registration requirements

- b) Informing the Secretariat regarding selection of water auditor, meter installation and testing
- c) Inform the [Regulator] and the PMU in case of change of name, legal status, location, area of operation
- d) Any other information that the Secretariat may require

4.2 Reporting requirements of PMU include:

- a) Informing participants about registration
- b) Intimating participants in case of rejection of application, incomplete data.
- c) Informing participants about methodologies of establishing baselines and empaneled agencies.
- d) Informing participants about metering and technical specifications.
- e) Providing information on testing schedule.
- f) Issuing electronic WRCs to consumers.
- g) Confirming collection of fees and charges.
- h) Making public all policies, minutes of meetings and decisions on dispute resolution.
- i) Any other material information on the WRC project.

5. Fees

5.1 The [Regulator] in consultation with the

Advisory Committee shall notify the fee structure including penalties for delayed compliance by the obligatory entities.

5.2 Payment of fees shall be made by electronic mode by online transfers.

6. Timeline

6.1 After its constitution, the Advisory Committee will set the dates for stakeholder consultations, finalise rules and publish announcements of the WRC scheme.

6.2 Each phase of the WRC scheme will involve baseline period of one year, followed by target period of the next year and assessment period of the third year. After the launch of the WRC scheme, the trading for Phase 1 is expected to start within 12 months.

6.3 On conclusion of the assessment period of a specific phase, an independent third party will be assigned and engaged to carry out an evaluation of the scheme.

6.4 Based on the evaluation report, the Advisory Committee will decide the date for launch of the next phase of the WRC scheme, with increase in participation in subsequent phases. For instance, under Phase 2, large housing complexes (that are separate bulk water entitlement holder's vis-à-vis the urban local bodies) shall join the scheme, and under Phase 3, large agricultural firms shall be included in the WRC scheme.





CONTACTS:

2030 WATER RESOURCES GROUP

2030wrg@worldbank.org