

Public Disclosure Authorized

Public Disclosure Authorized

Public Disclosure Authorized

Public Disclosure Authorized



**TECHNICAL REPORT 21/22**

# **DIRECT UTILIZATION OF GEOTHERMAL RESOURCES**



© 2022 November | International Bank for Reconstruction and Development / The World Bank  
1818 H Street NW, Washington, DC 20433  
Telephone: 202-473-1000; Internet: [www.worldbank.org](http://www.worldbank.org)  
Some rights reserved.

### **Rights and Permissions**

The material in this work is subject to copyright. Because the World Bank encourages dissemination of its knowledge, this work may be reproduced, in whole or in part, for noncommercial purposes if full attribution to this work is given. Any queries on rights and licenses, including subsidiary rights, should be addressed to World Bank Publications, World Bank Group, 1818 H Street NW, Washington, DC 20433, USA; fax: +1-202-522-2625; e-mail: [pubrights@worldbank.org](mailto:pubrights@worldbank.org). Furthermore, the ESMAP Program Manager would appreciate receiving a copy of the publication that uses this publication for its source sent in care of the address above, or to [esmap@worldbank.org](mailto:esmap@worldbank.org).

This work is available under the Creative Commons Attribution 3.0 IGO license (CC BY 3.0 IGO) <http://creativecommons.org/licenses/by/3.0/igo>. Under the Creative Commons Attribution license, you are free to copy, distribute, transmit, and adapt this work, including for commercial purposes, under the following conditions:

**Attribution**—Energy Sector Management Assistance Program. 2022. Direct Utilization of Geothermal Resources. Technical Report 21/22. Washington, DC: World Bank. License: Creative Commons Attribution CC BY 3.0 IGO

**Translations**—Add the following disclaimer along with the attribution: This translation was not created by The World Bank and should not be considered an official World Bank translation. The World Bank shall not be liable for any content or error in this translation.

**Adaptations**—Add the following disclaimer along with the attribution: This is an adaptation of an original work by The World Bank. Views and opinions expressed in the adaptation are the sole responsibility of the author(s) of the adaptation and are not endorsed by The World Bank.

**Third-Party Content**—The World Bank does not necessarily own each component of the content contained within the work and does not warrant that the use of any third-party owned individual component or part contained in the work will not infringe on the rights of those third parties. If you wish to reuse a component of the work, it is your responsibility to determine whether permission is needed for that reuse and to obtain permission from the copyright owner. Examples of components can include, but are not limited to, tables, figures, or images.

### **Production Credits**

Production Editor | Heather Austin, The World Bank

Designer | Circle Graphics, Inc.

Cover Image | ©Helga J. Svavarsdottir. Used with permission. Further permission required for reuse.

All images remain the sole property of their source and may not be used for any purpose without written permission from the source.

# CONTENTS

v	<b>LIST OF ABBREVIATIONS</b>	37	<b>3. THE ENABLING ENVIRONMENT: SETTING UP FOR SUCCESS</b>
vi	<b>ACKNOWLEDGMENTS</b>	38	Geothermal Knowledge
vii	<b>EXECUTIVE SUMMARY</b>	40	Supportive Governmental Policies
1	<b>1. GEOTHERMAL DIRECT USE: TOWARDS SUSTAINABLE DEVELOPMENT</b>	45	Legal Framework
2	Current Status	52	Social Acceptance and Local Consultation
6	Socioeconomic Benefits	57	<b>4. PROJECT DEVELOPMENT: DESIGNING AND PREPARING GEOTHERMAL PROJECT</b>
15	<b>2. DIRECT USE APPLICATIONS: MATCHING RESOURCE TO MARKET</b>	58	System Design
15	Space Heating, Cooling, and Domestic Hot Water	68	Key Components and Costs
20	Agriculture and Agro-industry Sectors	76	Project Preparation
21	Aquaculture	81	<b>REFERENCES</b>
29	Industrial Uses	87	<b>ANNEX A. EXAMPLES OF LEVELIZED COST OF HEAT ESTIMATES OF DIRECT-USE INSTALLATIONS</b>
33	Bathing and Recreation		

<b>List of Figures</b>			
<b>Figure ES.1: Global Overview of Low- and Medium-Temperature (30–150°C) Geothermal Resources</b>	viii	<b>Figure 2.3: Process of Seawater Fish Farming Using Geothermal Resources</b>	23
<b>Figure ES.2: Direct Use of Geothermal Energy Worldwide, 1995–2020</b>	ix	<b>Figure 2.4: Schematic Diagram of a Decoupled Aquaponic System</b>	24
<b>Figure ES.3: Potential Applications, Depending on Temperature of the Geothermal Fluid</b>	x	<b>Figure 2.5: Comparison of Cost and CO<sub>2</sub> Emissions among Different Energy Sources for Drying Grain</b>	26
<b>Figure ES.4: Examples of Geothermal Direct Use and Gender Equality: Gaps, Opportunities, and Targets</b>	xiii	<b>Figure 2.6: Temperature Range for Common Industrial Process Applications</b>	30
<b>Figure ES.5: Schematic Design of Geothermal Systems</b>	xiv	<b>Figure 2.7: Number of Thermal/Mineral Springs Establishments and Revenues by Region</b>	34
<b>Figure ES.6: Stage Gate Process for Geothermal Direct Use Projects</b>	xvi	<b>Figure 3.1: Key Components of Enabling Environment for Geothermal Direct Utilization</b>	38
<b>Figure 1.1: Global Overview of Low- and Medium-Temperature (30–150°C) Geothermal Resources</b>	2	<b>Figure 3.2: Information Characterizing Geothermal Resources</b>	39
<b>Figure 1.2: Direct Use: Typical System with Geothermal Fluid Utilized through a Heat Exchanger</b>	3	<b>Figure 3.3: Examples of Geothermal Direct Use and Gender Equality: Gaps, Opportunities, and Targets</b>	55
<b>Figure 1.3: Global Renewable Heat Consumption by Fuel and Technology, 2019</b>	3	<b>Figure 4.1: Direct Use from Self-Flowing Artesian Geothermal Resources</b>	59
<b>Figure 1.4: Direct Use of Geothermal Energy Worldwide, 1995–2020</b>	4	<b>Figure 4.2: Self-Flowing Drilled Well</b>	62
<b>Figure 1.5: Geothermal Electrical and Thermal Generation</b>	5	<b>Figure 4.3: Pumped Production Well without Reinjection</b>	63
<b>Figure 1.6: Geothermal Direct Use and Sustainable Development Goals</b>	6	<b>Figure 4.4: Direct Use from Geothermal Doublet</b>	64
<b>Figure 1.7: Example of a Geothermal Industrial Park: Hellisheidi, Iceland</b>	11	<b>Figure 4.5: Combined Production: Binary GPP with Air-Cooled Condenser for Waste Heat from the Cooling Air Stream</b>	65
<b>Figure 1.8: Heat Generation from Renewables and Waste by Source Globally, 1990–2017</b>	12	<b>Figure 4.6: Combined Production: Single-Flash GPP with Spray Condenser</b>	66
<b>Figure 2.1: Potential Applications, Depending on Temperature of the Geothermal Fluid</b>	16	<b>Figure 4.7: Ratio of Heat Potential/Electricity Produced as a Function of Enthalpy: Single Flash</b>	66
<b>Figure 2.2: Potential Uses of Geothermal Energy in the Agricultural Sector</b>	21	<b>Figure 4.8: Ratio of Heat Potential/Electricity Produced as a Function of Temperature: Binary</b>	67
		<b>Figure 4.9: Stage Gate Process for Geothermal Projects</b>	79

## List of Tables

<b>Table 4.1: Geothermal Fluid Required to Give an Equivalent of 1 Mw<sub>th</sub> for Various Temperature Drops</b>	<b>57</b>
<b>Table 4.2: Comparison of Various Geothermal Utilization Systems</b>	<b>72</b>
<b>Table 4.3: Low-Temperature Geothermal Wells: Size and Output</b>	<b>73</b>
<b>Table 4.4: Financing Options for the Different Stages of a Geothermal Project</b>	<b>80</b>

## List of Boxes

<b>Box 1.1: Geothermal Heat Pumps</b>	<b>4</b>
<b>Box 1.2: Example of Alternative Heating in Sweden</b>	<b>14</b>
<b>Box 2.1: Geothermal District Heating System, Reykjavík, Iceland</b>	<b>17</b>
<b>Box 2.2: Geothermal District Heating, China</b>	<b>18</b>
<b>Box 2.3: Space Cooling, Chena Hot Springs Resort, Alaska</b>	<b>19</b>
<b>Box 2.4: Greenhouse Horticulture at the Oserian Flower Farm in Naivasha, Kenya</b>	<b>22</b>
<b>Box 2.5: Microalgae Production, Saganatura, Iceland</b>	<b>23</b>
<b>Box 2.6: Fish Drying, Iceland</b>	<b>25</b>
<b>Box 2.7: Industrial Food Dehydrator, Nayarit, Mexico</b>	<b>27</b>
<b>Box 2.8: Processing Milk Using Geothermal Resources: Miraka, New Zealand</b>	<b>29</b>
<b>Box 2.9: Utilization of CO<sub>2</sub> from Geothermal Resources, Iceland</b>	<b>31</b>
<b>Box 2.10: The Rittershoffen Heat Plant, France</b>	<b>32</b>
<b>Box 2.11: Geosilica, Iceland</b>	<b>33</b>
<b>Box 2.12: Takhini Hot Springs, Yukon, Canada</b>	<b>35</b>
<b>Box 2.13: Blue Lagoon Geothermal Spa, Iceland</b>	<b>36</b>
<b>Box 3.1: National Policies Encourage Geothermal Energy in the Netherlands</b>	<b>41</b>
<b>Box 3.2: Risk Sharing Mechanism in Turkey</b>	<b>43</b>
<b>Box 3.3: Incentive and Support Mechanisms in France and Iceland</b>	<b>45</b>
<b>Box 3.4: Regulating Direct Uses of Geothermal in Mexico</b>	<b>46</b>
<b>Box 3.5: Environmental and Social Impact Assessment</b>	<b>51</b>
<b>Box 3.6: Eco-Industrial Parks</b>	<b>51</b>

<b>Box 3.7: Community Engagement in Italy and New Zealand</b>	<b>53</b>	<b>Box 4.5: Cascaded Use of Geothermal in Húsavík, Iceland</b>	<b>69</b>
<b>Box 4.1: Artesian Well: A Greenhouse Heating System in Flúðir, Iceland</b>	<b>60</b>	<b>Box 4.6: Integrated Use of Geothermal in Reykjanes, Iceland</b>	<b>70</b>
<b>Box 4.2: Artesian Well: Hot Water Beach in Mercury, New Zealand</b>	<b>61</b>	<b>Box 4.7: The Role of Geothermal Parks in Waste Reduction in Iceland</b>	<b>71</b>
<b>Box 4.3: Artesian Well: Multiple Uses in Deildartunguhver, Iceland</b>	<b>62</b>	<b>Box 4.8: Stage Gate Process for Geothermal Projects: Explanations</b>	<b>77</b>
<b>Box 4.4: Geothermal Doublet: District Heating in Paris, France</b>	<b>64</b>	<b>Box 4.9: Developing a Geothermal Resource in One or More Phases</b>	<b>78</b>

## LIST OF ABBREVIATIONS

CO <sub>2</sub>	carbon dioxide
EIP	eco-industrial park
ESMAP	Energy Sector Management Assistance Program
GDU	geothermal direct use
GIP	geothermal industrial park
GPP	geothermal power plant
HCU	heat conversion unit
IEA	International Energy Agency
kg	kilogram
kg/s	kilograms per second
km	kilometer
LCOH	levelized cost of heat
m <sup>2</sup>	square meter
mm	millimeter
MWe	megawatt electric
MWth	megawatt thermal
OPEX	operating expenditure
rpm	rotation per minute
RSM	risk-sharing mechanism
SDG	Sustainable Development Goal
W	watt

All currency is in United States dollars (US\$, USD), unless otherwise indicated.

## ACKNOWLEDGMENTS

This report is a collaborative effort of the World Bank Group's Energy Sector Management Assistance Program (ESMAP) and the Foreign Ministry of Iceland. Its preparation was overseen by a team of World Bank staff at ESMAP, led by Elin Hallgrimsdottir (Senior Energy Specialist), Joeri Frederik de Wit (Energy Economist), and Yassine Berkouch (Intern).

The report was prepared by a team of Icelandic experts funded by the Foreign Ministry of Iceland: Lilja Tryggvadottir (Mannvit), Carine Chatenay (Verkís), Þorleikur Jóhannesson (Verkís), Helga Tulinius (ISOR), Margeir Gissurarson (MATIS), and Baldvin Björn Haraldsson (BBA Fjeldco).

The teams are grateful for the constructive comments and contributions of the expert reviewers of the report: Jack Kiruja (IRENA) and Marit Brommer (IGA), and our World Bank colleagues: Almudena Mateos Merino, Barbara Ungari, Megan Meyer, Muchsin Chasani Abdul Qadir, and Nathyeli Acuna Castillo.

The teams extend their appreciation to Rohit Khanna and Gabriela Gabriela Elizondo Azuela (former and current Program Managers, ESMAP) for their guidance and support throughout the development of the report, and express their gratitude to ESMAP for financial and technical support, and especially to the Icelandic Ministry of Foreign Affairs for funding this report. ESMAP is a partnership between the World Bank and 24 partners to help low- and middle-income countries reduce poverty and boost growth through sustainable energy solutions.

ESMAP's analytical and advisory services are fully integrated within the World Bank's country financing and policy dialogue in the energy sector. Through the World Bank Group (WBG), ESMAP works to accelerate the energy transition required to achieve Sustainable Development Goal 7 (SDG7) to ensure access to affordable, reliable, sustainable, and modern energy for all. It helps shape WBG strategies and programs to achieve the WBG Climate Change Action Plan targets.



## EXECUTIVE SUMMARY

Geothermal Direct Use (GDU) is the use of geothermal resources to create valuable commodities from heat, minerals and gases. The term *GDU* arises because commercial development of geothermal resources has historically centered on electricity generation, which *indirectly* uses the resource by converting the energy in its fluids to electricity at geothermal power plants. *Direct* use of geothermal resources therefore refers to all applications in which the commodity of value is extracted directly from geothermal fluids.

This report is a primer on the concept of GDU, why countries should explore its potential, with a focus on the utilization of geothermal heat, and how it can be developed to bring economic and social benefits to different sectors of the population. The report is written with energy sector policy makers and technocrats in mind but can serve to introduce GDU to all those interested in learning more about it.

## CURRENT STATUS AND SOCIOECONOMIC BENEFITS

Geothermal resources are created deep in the earth and stored in geologic formations in its crust. They are fluids that may be characterized by various parameters such as temperature, pressure, and chemistry. Perhaps the most common categorization—and the one that is used in this report—is temperature: low (~20 to 80°C), medium (80 to 150°C), and high (>150°C). This is a somewhat arbitrary yet practical way to define the resource and align it with potential uses.

High-temperature resources are often prioritized for electricity production, whereby the heat energy of the geothermal fluid is converted to electrical energy. Low- to medium-temperature resources are less suitable for electricity generation but are much more widespread (Figure ES.1) and lend themselves to direct-use applications. The main focus of this report is on low- to medium-temperature geothermal resources in the context of utilizing the resource directly. High-temperature resources will, however, be discussed in the context of cogeneration (i.e., when heat is cogenerated with electricity) or cascaded use (whereby heat is extracted from the geothermal resources in a stepped process of sequential applications).

A strong rationale for GDU lies in its potential to help decarbonize heat. About half of all end-use energy consumption globally is in the form of heat. This compares to 20 percent for electricity and 30 percent for transport. Yet heat supply has proven difficult to decarbonize. Renewable technologies that are becoming cost effective in generating electricity have yet to break through in displacing heating fuels. Currently only around 10.4 percent of global heat demand is being met by renewables and only 0.3 percent by GDU (IEA 2020c).

Global installed capacity of GDU for heat is 107 GW, 40 percent of which is installed in China. The momentum for GDU is picking up, however, with installed capacity increasing over 50 percent since 2015 (REN21 2020, 92). Currently 88 countries report direct utilization of geothermal energy in the amount of around 1 million terajoules per year, displacing some 600 million barrels of equivalent oil and over 250 million tons of carbon dioxide (CO<sub>2</sub>) annually. The installed global capacity in 2020 is concentrated in space heating and cooling (75%), bathing and swimming (18%), and other (7%) (Lund and Toth 2021) (Figure ES.2).

GDU is also recognized for providing other benefits at local, national, and global levels by strengthening energy independence, advancing the development of a varied sustainable energy sector, and supporting diverse end-use sectors.

**FIGURE ES.1: GLOBAL OVERVIEW OF LOW- AND MEDIUM-TEMPERATURE (30–150°C) GEOTHERMAL RESOURCES**

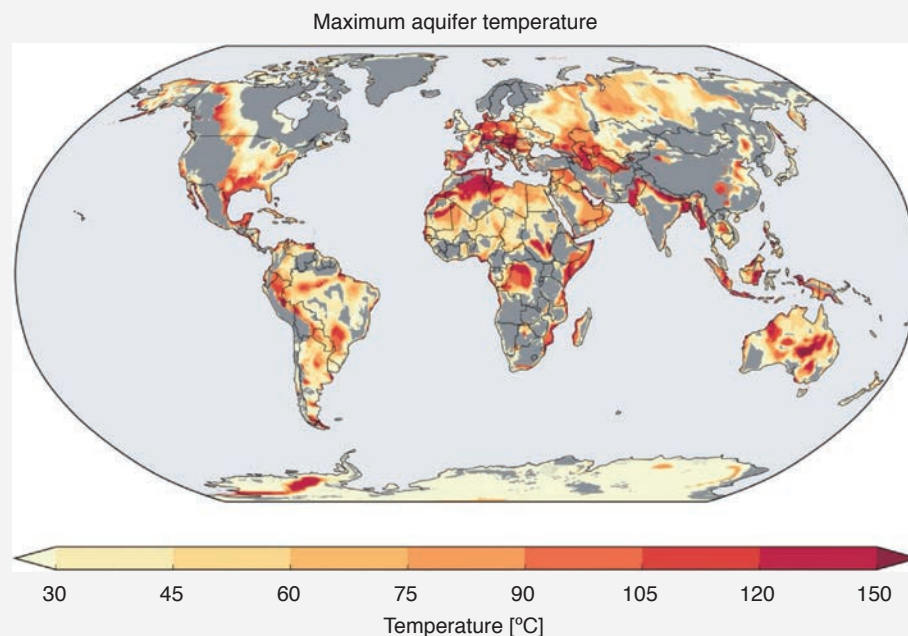

Source: Limberger et al. 2018, Figure 8.

Note: Temperatures are computed for areas with over 100-meter sediment thickness and limited to a maximum depth of 3 kilometers.

GDU not only provides benefits to developers as a potentially low-cost, low emission heat source, it also brings multiple socioeconomic benefits. To achieve climate targets, the heating sector must decarbonize rapidly (IEA 2021). Beyond decarbonization, GDU provides multiple benefits that contribute more broadly to SDG 7; on universal access to affordable and clean energy as well as other SDGs (see Figure ES.3), including poverty eradication, gender equality, mitigation of and adaption to climate change, food security, health, education, sustainable cities and communities, clean water and sanitation, jobs, innovation, transport, and addressing refugees and situations of displacement (UN 2018). GDU contribution to the SDGs can be summarized as:

- **Zero hunger** (SDG 2), through its use, for example, in greenhouse agriculture, food drying, food preservation, aquaculture, and soil warming
- **Gender equality** (SDG 5), by providing employment, training, and entrepreneurial opportunities, often at a local level that can benefit women as well as men, as evidenced in a recent ESMAP report (ESMAP, 2019)
- **Decent work and economic growth** (SDG 8), as an underlying resource for many business activities, whether as heat input for the production of goods, as a resource for the service industry (such thermal spas and tourism), or as a source of valuable minerals and gases
- **Industry, innovation, and infrastructure** (SDG 9), by creating or expanding varied local enterprises—for example, through industrial parks, which are already demonstrating innovative ways to maximize the value of geothermal resources

**FIGURE ES.2: DIRECT USE OF GEOTHERMAL ENERGY WORLDWIDE, 1995–2020**

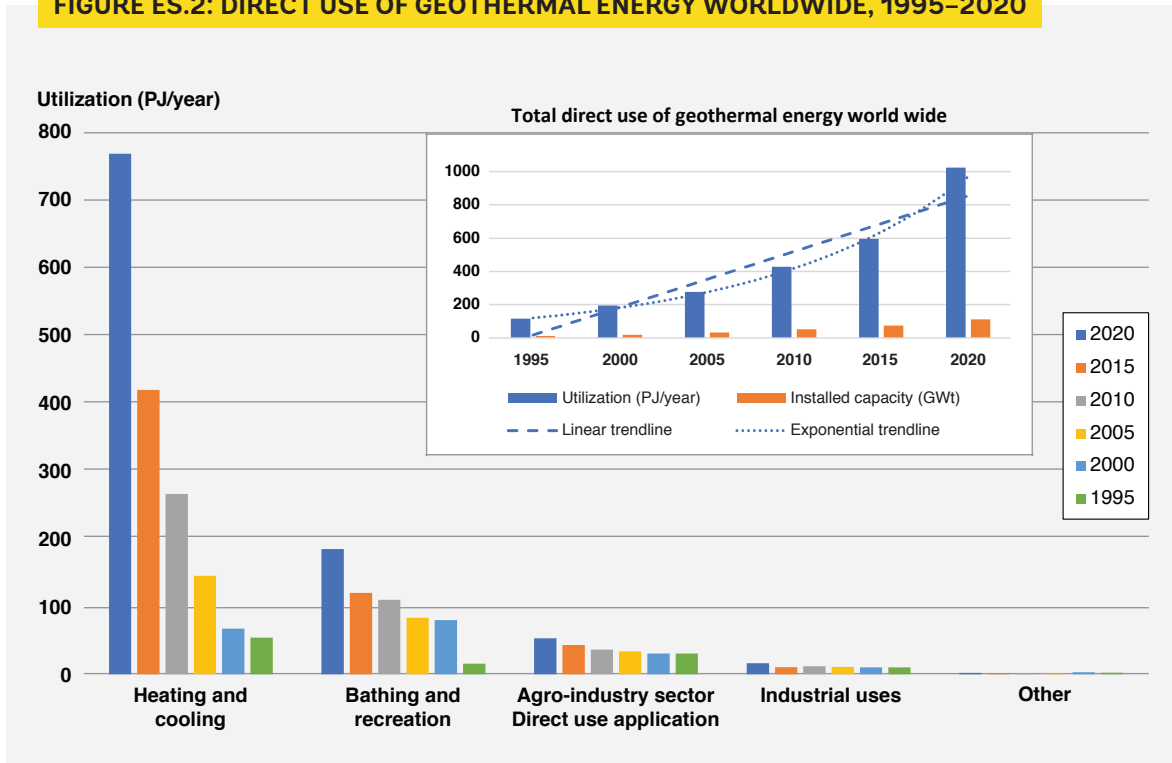

Source: Lund and Toth 2021.

- **Affordable and clean energy** (SDG 7), **sustainable cities and communities** (SDG 11), **responsible consumption and production** (SDG 12), **climate action** (SDG 13), by providing a clean and renewable sources for heat as a replacement for fuels that emit greenhouse gases—for example, district heating systems, food processing, reduction of food waste

## GEOTHERMAL DIRECT USE APPLICATIONS

The productive uses of heat from geothermal resources—GDU applications—mostly depend on the temperature of the fluid and its chemical constraints. Figure ES.3 gives an overview of the various applications proven possible thus far. Unlike geothermal power generation, which requires medium- to high-temperature geothermal resources, direct-use applications exist for a wide range of low to medium temperatures.

For the purpose of this study, GDU is categorized by sector: space heating and cooling, agriculture and agro-industry, industrial uses, and bathing and recreation (see also Figure ES.3).

**Space heating and cooling**, the indoor climates of homes and buildings, will follow daily and annual climate patterns unless houses are either heated or cooled. To ensure comfortable temperature conditions, space heating and cooling are often necessary. While there are numerous geothermal district heating systems—for example, in Iceland, Turkey, Hungary and China—there are relatively few geothermal district cooling systems, and these tend to be implemented on a small scale. A notable example is the geothermal absorption cooling unit running at the offices of Izmir Jeotermal in Turkey with a cooling capacity of 210 kilowatts thermal (Mertoglu et al. 2020). However, ground source heat pumps, which have much broader applications are also being installed mostly for the heating and cooling of household and buildings.

**FIGURE ES.3: POTENTIAL APPLICATIONS, DEPENDING ON TEMPERATURE OF THE GEOTHERMAL FLUID**

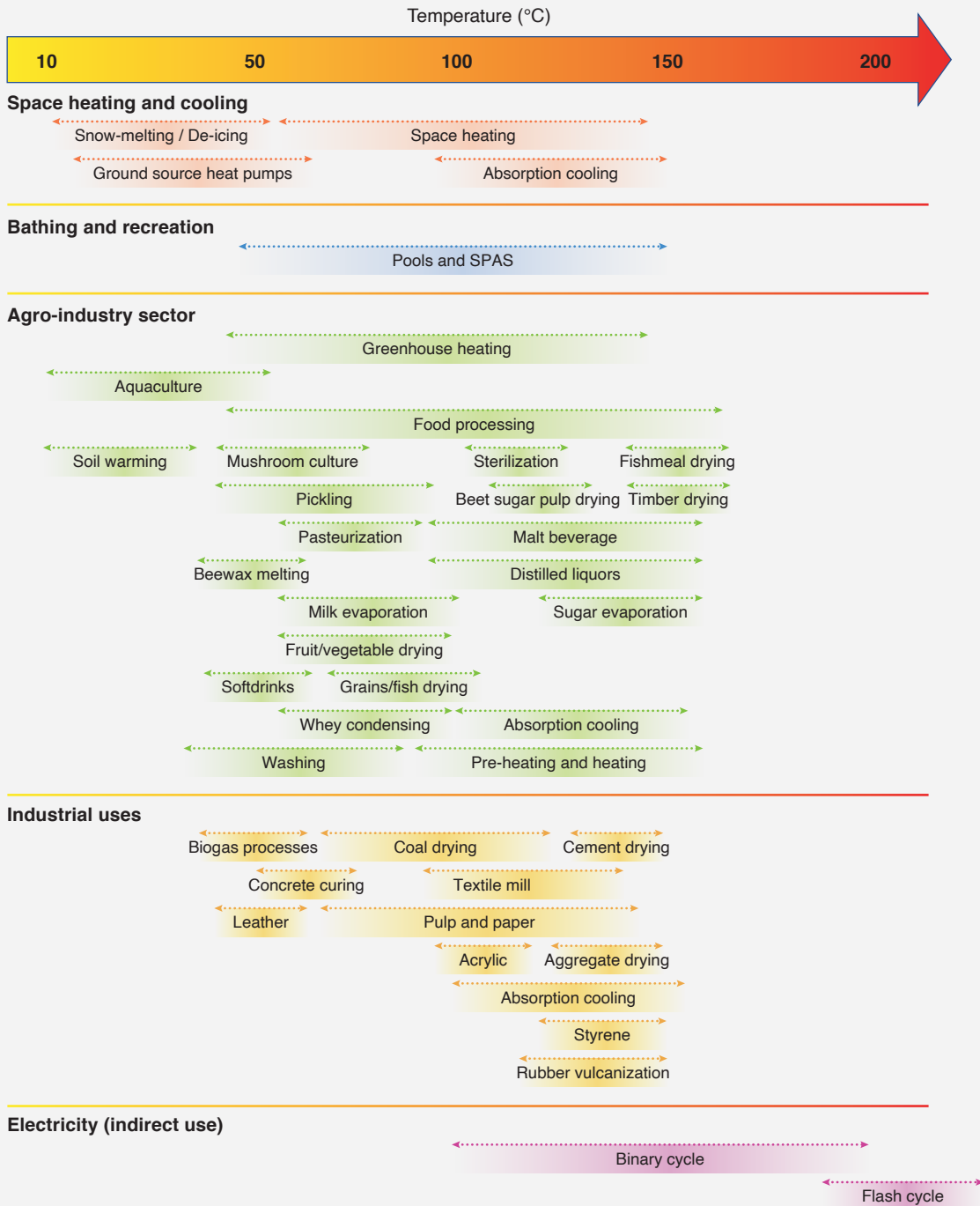

Source: Original compilation based on Lindal diagram.

**Agriculture and agro-industry sector.** The agricultural sector, including agro-industry (for example processing and packing of food), faces diverse challenges to feed humanity in a sustainable manner. This report classifies potential geothermal applications in the agriculture and agro-industry sectors in three categories: horticulture, aquaculture, and agro-industrial processes.

*Horticulture* is the science and art of development, sustainable production, marketing, and the use of high-value, intensively cultivated food and ornamental plants. Geothermal heat is considered an especially interesting option for commercial greenhouse operations in cold climates with high heating requirements. In hot regions, the geothermal energy in greenhouses is used more for humidity control or to counteract the night cold in desert areas.

*Aquaculture*, also known as aquafarming, is the controlled cultivation of aquatic organisms, such as fish, crustaceans, mollusks, algae, and other organisms of value, including aquatic plants. The geothermal fluid can in some cases be used directly or mixed with freshwater to obtain the optimized temperature in ponds or pools. Heat exchangers might be required if the chemical composition of the geothermal fluid is unsafe for the aquatic animals or if reinjection into the reservoir is planned.

*Agro-industrial processes* are the methods used to further prepare food products for the market, such as drying, pasteurizing, sterilization, evaporation, and distillation.

During the *drying* process, there will be some physical, chemical, and biological changes in food that may alter its quality and nutritional value. The product being dried and its intended use are what determine the heat level applied in the process. The process temperature for agro-industrial drying starts at 28°C, depending on the product (Kinyanjui 2013).

*Pasteurization* can be applied to various food processes, including foods such as dairy, shrimp, fruit juices, and marinated products. The temperature range is often 60 to 100°C (e.g., for milk pasteurization).

*Sterilization* commonly utilizes temperatures above 110°C, and complete sterilization is obtained by heating a substance to 121.1°C for 15 minutes. This heat profile is used in hospitals and laboratories. In the canning industry, a heat profile of 112°C and 115°C for 20 to 30 minutes is used.

*Evaporation* is used in the food industry to produce a concentrate by heating a liquid to the boiling point to remove water as vapor. It is used in various processes, including the production of tomato paste, jams, syrups, salts, and various fruit concentrates, as well as in the dairy industry (e.g., condensed milk). Evaporation temperatures for various foods depend on the process and starts at 40°C.

*Distillation* is a process in which liquid is separated by vaporization and recondensed by cooling the vapor. The temperature required for distillation and evaporation varies depending on the product being processed and the processing method applied. Common operating temperatures range from 80 to 120°C.

**Industrial uses** encompass a rather wide range of applications, requiring fluid at low, medium, and higher temperatures to preheat, wash, evaporate, distill, separate, dry, or even chill (via heat pumps or absorption coolers). Industrial uses encompass, for example, extraction of minerals (such as silica, sulfur, gases, salts, lithium, or other precious metals) and gases from the geothermal resources. Extraction of minerals and utilization of gases is reliant on the chemical composition of the geothermal resource.

**Bathing and recreation.** Areas with geothermal features, from volcanoes to thermal springs, are attractive for leisure and tourism. Geothermal bathing and swimming facilities have long been established in local cultures, some since ancient times (e.g., Turkey, Iceland, and Japan). Fluids often hold dissolved minerals, some known for their potential therapeutic properties (e.g., the production of skincare products). According to a survey by the Global Wellness Institute, nearly 27,000 establishments across the world used thermal springs for bathing and other traditional practices in 2017 (Global Wellness Institute 2018). The worldwide market value of products and services produced in this sector is estimated at \$56 billion.

## AN ENABLING ENVIRONMENT FOR GEOTHERMAL DIRECT USE

Where does it make the most sense to support the development of the direct use of geothermal resources? This question cannot be easily answered unless the economic feasibility and social desirability are thoroughly assessed for each geothermal area. Even in cases where a suitable resource is available for needed applications, the viability of GDU projects depends on an adequate enabling environment. This requires support from public and private stakeholders, including local communities that are adjacent to geothermal resources and that can benefit from their development. In this report, a supportive enabling environment is characterized by four key pillars.

**Geothermal knowledge.** Key to the development of geothermal utilization is information about a country's geothermal resources: geological data, characteristics, locations, estimated accessibility and volume, and composition of the geothermal fluids. Mapping the geothermal potential at a regional or country level is a necessary first step. When mapping the technical potential of geothermal resources, it is important to consider local conditions and the environmental and social implications that these locations have; at this stage in planning, the evaluation is high level. The quality of data available on local resources, coupled with information on potential markets for various applications, is critical to determine the feasibility of GDU projects. Studies built on reliable exploration data can help identify and prioritize potential projects.

Geothermal resource information reduces project risks during the initial development phase; however, it should be noted that if installing a GDU project at an existing power plant, the resource risk has been minimized. A country's government should ensure that geological surveys and geothermal mapping are made available for use by potential developers and researchers while ensuring incentives for the private sector to acquiring such information are created, at least in the short run. This approach fosters a business environment favorable to investment in geothermal. Typical data gathered encompass geological, geophysical, and geochemical characteristics, as well as estimated resource depth. Drilling data—such as those on temperature, pressure, and a fault's permeability, as well as groundwater data—are also valuable for environmental monitoring and sustainability. A geothermal data management system maintained by a public regulator is desirable in order to safeguard valuable information for private investors as well as the public.

In many countries with geothermal energy resources, basic relevant knowledge and experience may be lacking, which can pose a barrier to innovative thinking about how to use and effectively deploy them. This can be addressed at the national level by implementing **educational strategies** with emphasis on fields related to geothermal utilization. It is important to inform policy makers of GDU's benefits, with a focus on direct use as a contributor to socioeconomic development. The incentives of gender equality and inclusiveness can also be emphasized in these efforts (ESMAP, 2019).

**Supportive government policies.** Countries have various tools at hand to influence the undertaking of certain projects in their territories as part of their overall national goals and policies.

Investment in GDU projects can come from both the private and public sectors or in the form of a public-private partnership. Globally, the public sector has been a major developer of geothermal resources. The main reasons for this are that governments can usually issue debt at lower interest rates than the private sector, allowing for a lower acceptable return on investment, and can take on more risk. Importantly, governments can also set up risk sharing mechanisms that protect private entities during exploration phases and ensure that the benefits are shared when geothermal resources are found and developed. The nonfinancial benefits of GDU are also key, since governments often have policy goals for their investments other than simply maximizing returns, such as diversification of the country's energy sector, reduction of the country's long-term greenhouse gas emissions, stimulation of the national economy through job creation, and promotion of gender equality within the local community, as well as in the geothermal sector (ESMAP, 2019).

**A legal framework favorable to GDU.** The importance of having a supportive legal framework to successfully implement the direct use of geothermal resources cannot be emphasized enough. In countries where the relevant legislation is unclear or nonexistent, developers simply lack basic confidence in the system, or they feel the rules of the game are inadequate in supporting their investment in geothermal, hampering the development of this sector. The main objective of a supportive legal framework is to ensure a transparent, cohesive, and reliable environment for the development of the geothermal sector in general and direct use in particular. This is a prerequisite for securing long-term investments in the sector and the sustainability of the resource.

The legal framework should encompass the following aspects: definition of geothermal resources; clear ownership and access rights; licensing, permits, and fees; institutional jurisdiction; clear delineation of resource management principles and responsibilities; and environmental regulations.

**Social acceptance and community support.** Communities near geothermal areas may be affected by various aspects related to the development and operation of a project. It is therefore generally good practice to include the local community and its organizations early in the development (during the project planning stage) of a project and to conduct extensive public consultations. These can focus on the many benefits of GDU, such as a better quality of life, improved job opportunities, and a healthier society. Community involvement should be an objective, ideally supported by a legal framework; most importantly, this framework should be adopted by the management team of direct-use projects. Examples of gaps, opportunities, and targets are presented in Figure ES.4.

**FIGURE ES.4: EXAMPLES OF GEOTHERMAL DIRECT USE AND GENDER EQUALITY: GAPS, OPPORTUNITIES, AND TARGETS**

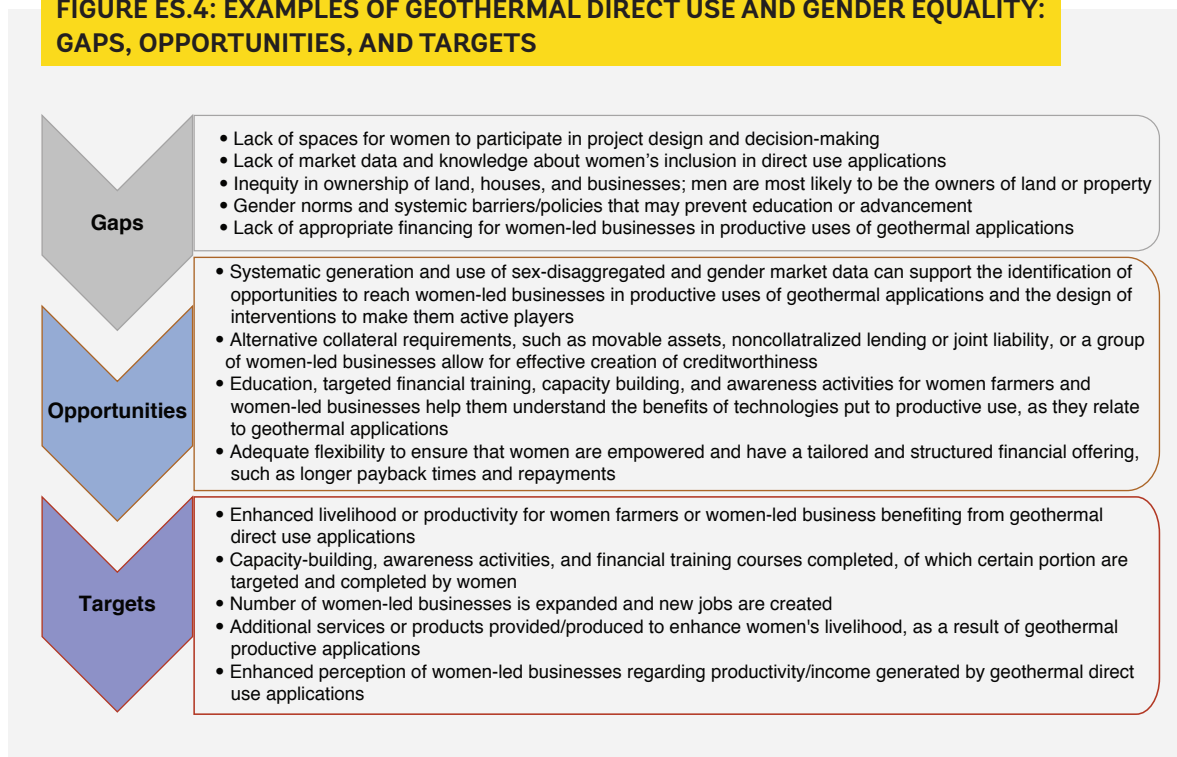

Source: Original compilation.

## GEOTHERMAL PROJECT DESIGN AND PREPARATION

Basic factors influencing the technical design of geothermal applications include the temperature and available flow rates, which determine the energy potential of a given resource. For a given flow rate, the thermal energy extraction is proportional to the water temperature drop that can be achieved by the application. For uses other than heating and cooling, the chemical composition of the fluid and the flow rate determines the feasibility.

The temperature range and locations for feasible direct-use applications have expanded alongside knowledge about geothermal resources and technologies for utilizing them. Common system designs include:

- Self-flowing artesian resources (i.e., natural hot springs)
- Self-flowing drilled wells
- Pumped production wells, with or without reinjection (to return fluids to their sources)
- Cogeneration, whereby both electricity and heat are produced
- Cascaded, integrated systems whereby energy from the same production well is used across multiple applications

Figure ES.5 shows a schematic design of a geothermal system.

The fluids are extracted for direct-use applications using equipment that is common in many industries and is thus widely available globally. Most geothermal direct-use systems consist of a wells (can be few meters

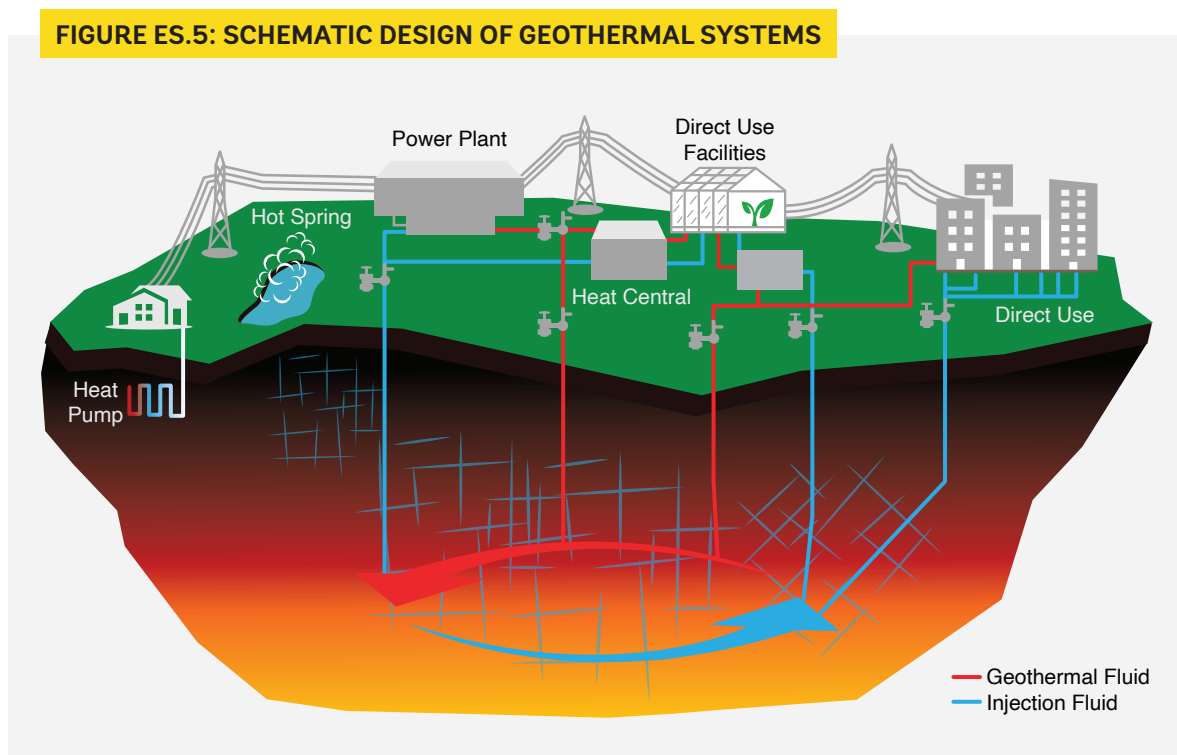



down to six km) to extract (and often reinject) fluids, pumps to circulate fluids, pipes for transportation and distribution, a heat exchanger for the resource's heat to be transferred to a secondary fluid, and control systems.

The method to transport geothermal fluid depends on the intended use. A single-pipe system is an open system using the geothermal fluid directly (e.g., for a hot spring or pool). It is more economical than a double-pipe system, but it can only be applied in cases when sustainable resource utilization does not require reinjection. To transport geothermal fluid from a geothermal field to a heat central or end user, a double pre-insulated piping system (preferably underground) is the common choice. The main driving factors determining whether it is economical to transport geothermal fluids are the cost of harnessing the geothermal heat, the energy price, the amount of water flowing, the annual utilization hours (capacity factor), the cost of pumping, and land rights.

The cost of a geothermal direct-use system is highly dependent on the resource, location (distance from end use), capacity factor, and chemistry. It is therefore challenging to define a standard cost; however, a typical cost evaluation for preliminary cost estimation is demonstrated in the report (see Chapter 4). In the United States (US), the levelized cost of heat (LCOH) assuming a 30-year lifetime, 5 percent discount rate, and overnight construction ranges from \$15 to \$105/MWh, depending on the location and resource, with an average of \$54/MWh (NREL 2021). The preparation of a geothermal project is often a long process that may involve up to 30 percent of the capital expenditure needed before the resource has been proven (highly dependent on drilling needs and available infrastructure). Therefore, it is very important to perform the project preparation in a systematic and disciplined way to make informed decisions at each stage.

The necessary effort to complete a geothermal projects varies, corresponding to its size and complexity. However, all geothermal project development, whether GDU or co-generation, involves similar project states, see Figure ES.6. After each stage it is essential that a decision is made whether to carry on with the project or not. It is therefore essential that all stakeholders in the project are clear on the project goals, risk and decision points. It should be noted that for ground source heat pumps system for a single house the project preparation starts at Project design stage after the project feasibility has been evaluated.

As with all geothermal projects, the direct use of low- to middle-temperature geothermal resources must be done with care. Overexploitation over a long period may have an irreversible impact on the resource or affect it in such a manner that it would take a long time to recover. Monitoring is therefore key to sustainable resource management. It is recommended that project developers be required to regularly report results to geo-surveys or appropriate authorities overseeing the utilization of local/national geothermal resources.

In the process of planning a GDU project, it is important for a developer to consider a wide range of factors that contribute to the success of a project. Many of these factors will need government participation and leadership (enabling environment), whereas others are the sole responsibility of the developer (both private and public).

It is the **responsibility of the government** to ensure that a strong legal and regulatory framework is in place to govern the permitting, and that land access and industrial/rural development plans are in place. Another important aspect is to plan for maximizing the projects' social and economic benefits. This can be done on multiple levels—for example, by mapping the capacity in the country and where to focus the capacity building. The government can make development regulations regarding local employment, gender equality, and inclusion of local communities.

The **developer's responsibility** is to ensure adequate project preparation by following the stage gate approach, apart from ensuring best practices in conducting studies to understand the geothermal resource,

**FIGURE ES.6: STAGE GATE PROCESS FOR GEOTHERMAL DIRECT USE PROJECTS**

*Geothermal Direct-Use Project: Cogeneration or Industrial Park*

Reconnaissance	Pre-feasibility	Feasibility	Project design	Construction	Operation
<ul style="list-style-type: none"> <li>• Desk top study</li> <li>• Market analysis/heating and cooling demand analysis</li> <li>• Preliminary E&amp;S study</li> <li>• <b>Decision to proceed</b></li> </ul>	<ul style="list-style-type: none"> <li>• Preliminary review of available resources</li> <li>• Pre-feasibility report</li> <li>• <b>Decision to proceed</b></li> </ul>	<ul style="list-style-type: none"> <li>• Due diligence on the resource assessment and resource management</li> <li>• Technical due diligence</li> <li>• ESIA</li> <li>• Feasibility study</li> <li>• Financial close</li> <li>• <b>Decision to tender</b></li> </ul>	<ul style="list-style-type: none"> <li>• Tender design</li> <li>• Tendering and procurement</li> <li>• Financial analysis</li> <li>• <b>Decision to Construct</b></li> </ul>	<ul style="list-style-type: none"> <li>• Detail desgin</li> <li>• Construction and supervision</li> <li>• Comissioning</li> </ul>	<ul style="list-style-type: none"> <li>• Maintenance</li> <li>• Refurbishment</li> <li>• Operation</li> <li>• <b>Decision to decommission</b></li> </ul>

*Independent Geothermal Direct-Use Project*

Reconnaissance	Pre-feasibility	Feasibility	Project design	Construction	Operation
<ul style="list-style-type: none"> <li>• Desk top study</li> <li>• Surface Exploration</li> <li>• Exploration report</li> <li>• Market analysis/heating and cooling demand analysis</li> <li>• Preliminary E&amp;S study</li> <li>• <b>Decision to proceed</b></li> </ul>	<ul style="list-style-type: none"> <li>• Exploration program</li> <li>• Exploration/test drilling</li> <li>• Reservoir assesment</li> <li>• Pre-feasibility report</li> <li>• <b>Decision to proceed</b></li> </ul>	<ul style="list-style-type: none"> <li>• Confirmation drilling (if needed)</li> <li>• Reservoir engineering</li> <li>• ESIA</li> <li>• Feasibility study</li> <li>• Decision to tender</li> <li>• Financial close</li> <li>• <b>Decision to tender</b></li> </ul>	<ul style="list-style-type: none"> <li>• Tender design</li> <li>• Tendering and procurement</li> <li>• Financial analysis</li> <li>• <b>Decision to Construct</b></li> </ul>	<ul style="list-style-type: none"> <li>• Detail desgin</li> <li>• Construction and supervision</li> <li>• Comissioning</li> </ul>	<ul style="list-style-type: none"> <li>• Monitoring</li> <li>• Maintenance</li> <li>• Make up drilling (if needed)</li> <li>• Refurbishment</li> <li>• Operation</li> <li>• <b>Decision to decommission</b></li> </ul>

Source: Adapted from Pálsson 2017.

Note: Ground source heat pumps for single house will start at project design after the feasibility has been evaluated.

environmental compliance, market analysis, and technical design. A developer’s responsibilities also involve ensuring engagement with stakeholders to demonstrate the benefits of the projects and to minimize the risk posed by local opposition to the project. Ensuring compliance with best practices for technical, environmental, and social aspects will improve access to financing. The financing requirements will depend on the project type, size, structure, and location; the capacity of the developer; and the risk appetite of financiers. In the early stages, however, the potential return on investment has to be weighed against the probability that no viable geothermal resource will be discovered.

# 1. GEOTHERMAL DIRECT USE: TOWARDS SUSTAINABLE DEVELOPMENT

Geothermal resources are fluids created within the earth and stored in geologic formations in its crust. They may be characterized by various parameters such as temperature, pressure, and chemistry and enthalpy. Perhaps the most common categorization—and the one that is used in this report—is by temperature: low (~20 to 80°C), medium (80 to 150°C), and high (>150°C). This practical categorization makes it easy to align the resource with its potential uses. High-temperature resources are often prioritized for electricity production, whereby the heat energy of the geothermal fluid is converted to electrical energy. Low- to medium-temperature resources are less suitable for electricity generation but are much more widespread (Figure 1.1) and lend themselves to direct-use applications. Geothermal Direct Use (GDU) refers to all applications where the commodity of value is extracted directly from geothermal fluids from heat, minerals, and gases.

The main focus of this report is on direct use of low- to medium-temperature geothermal resources. However, the report will also discuss direct use of high-temperature resources in the context of cogeneration (i.e., when heat is cogenerated with electricity) or cascaded use (whereby heat is extracted from the geothermal resources in a stepped process of sequential applications).

Beyond using heat for various direct purposes, it is possible to extract minerals such as silica (see Box 2.11), gases such as CO<sub>2</sub> (see Box 2.10) and other chemicals from geothermal resources. In particular lithium extraction from geothermal resources has gained increased attention due to lithium's importance in the growing battery industry. Several methods for lithium extraction (e.g., absorption and ion exchange) are being piloted and are nearly ready for commercial-scale demonstration, for example Salton Sea, USA (Warren 2021).

Direct utilization of any geothermal resources requires piping the geothermal fluids directly to a system that distributes the hot fluids that will be used by various applications. In Figure 1.2, shows a simple block-flow diagram of a geothermal production loop. In this case, a pumped production well (the fluid source) moves fluid to a heat exchanger, which in turn supplies heat to the user. Then the geothermal fluid continues to an injection well to return (reinject) the fluid to its source.

Each geothermal system is unique in its chemistry and the type of geological formation in which it is found. A thorough survey and study of the resource is critically important for the successful development of projects. Factors such as depth, accessibility, and abundance of the resource, as well as the characteristics of the geothermal fluid (such as whether it is corrosive or causes scaling, its gas content, and so on), need to be considered when deciding on a utilization method (see section 2 for further details).

Global development of direct utilization is at a stage where it would benefit tremendously from a focus on exploration, to investigate its technical and economic potential. Currently, most countries have limited public data available on the potential of GDU. The resource must be investigated across various development phases that include preliminary studies, modelling, and drilling (see section 4 for more details).

**FIGURE 1.1: GLOBAL OVERVIEW OF LOW- AND MEDIUM-TEMPERATURE (30–150°C) GEOTHERMAL RESOURCES**

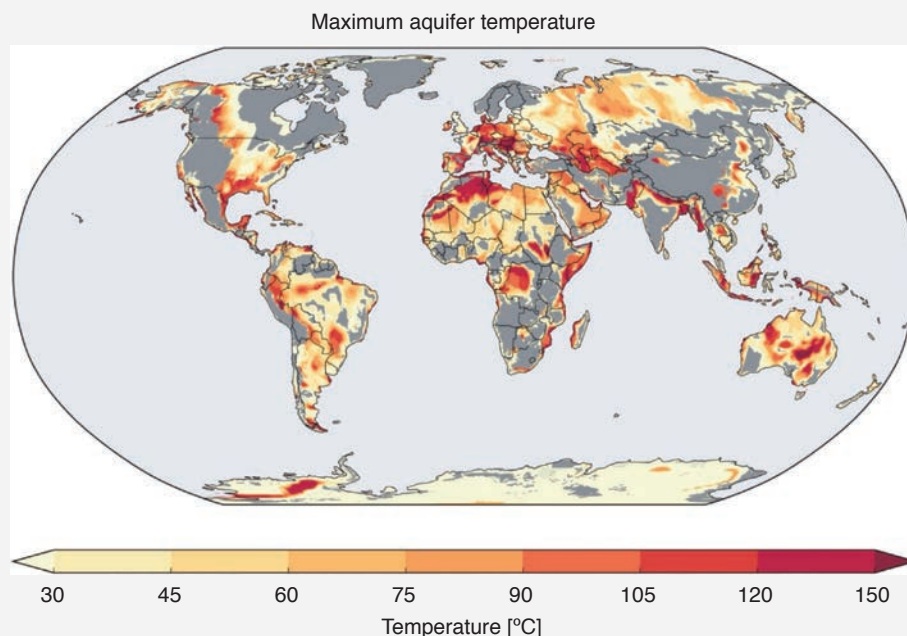

Source: Limberger et al. 2018, Figure 8.

Note: Temperatures are computed for areas with over 100-meter sediment thickness and limited to a maximum depth of 3 kilometers.

In theory, geothermal energy will last as long as the earth's core heats the fluids in the earth's crust. While some fluids emerge naturally through hot springs, most are exploited by drilling and pumping them out of reservoirs. Where sustainable, long-term use is the objective; the key is to reach a state where the natural recharge of the reservoir, combined with reinjection, is in equilibrium with the exploitation in terms of flow and temperature (Stefansson and Axelsson 2003). Overexploitation can be avoided by adapting a given project's scale (usage) to the resource's estimated potential, and then adopting efficient resource management that includes reinjection, monitoring, and modelling.

## CURRENT STATUS

Globally half of all end-use energy consumption is in the form of heat. This compares to 20 percent for electricity and 30 percent for transport. Renewables (not including biomass) met only 10.4 percent of the global heat demand in 2019, and GDU met only 0.3 percent (Figure 1.3) (IEA 2020c).

Currently 88 countries report direct utilization of geothermal energy in the amount of around 1 million terajoules per year, displacing some 600 million barrels of equivalent oil and over 250 million tons of carbon dioxide (CO<sub>2</sub>) annually. Installed global capacity in 2020 amounted to 107 gigawatts; 59 percent is concentrated in ground source heat pumps (see Box 1.1), 18 percent in bathing and swimming (see Figure 1.4), and 16 percent in space heating (Lund and Toth 2021). Overall, this amounted to a 52 percent increase in installed capacity from 2015, or an approximate 8.7 percent yearly increase (REN21 2020, 92).

**FIGURE 1.2: DIRECT USE: TYPICAL SYSTEM WITH GEOTHERMAL FLUID UTILIZED THROUGH A HEAT EXCHANGER**

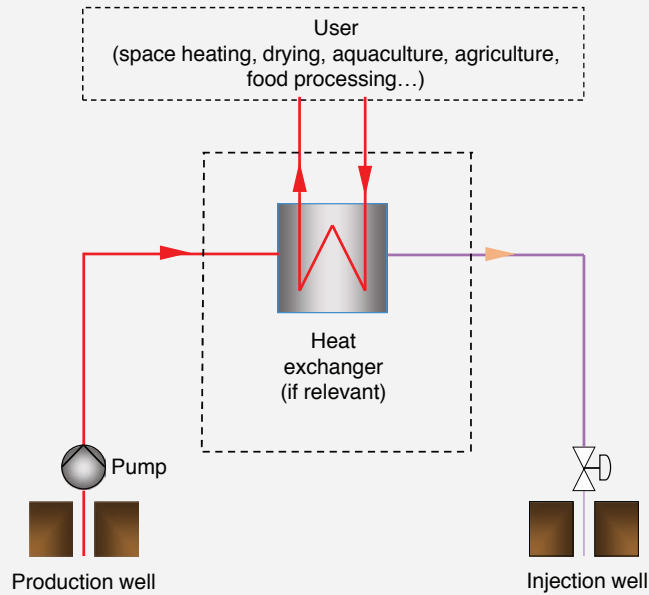

Source: Original compilation for this publication.

**FIGURE 1.3: GLOBAL RENEWABLE HEAT CONSUMPTION BY FUEL AND TECHNOLOGY, 2019**

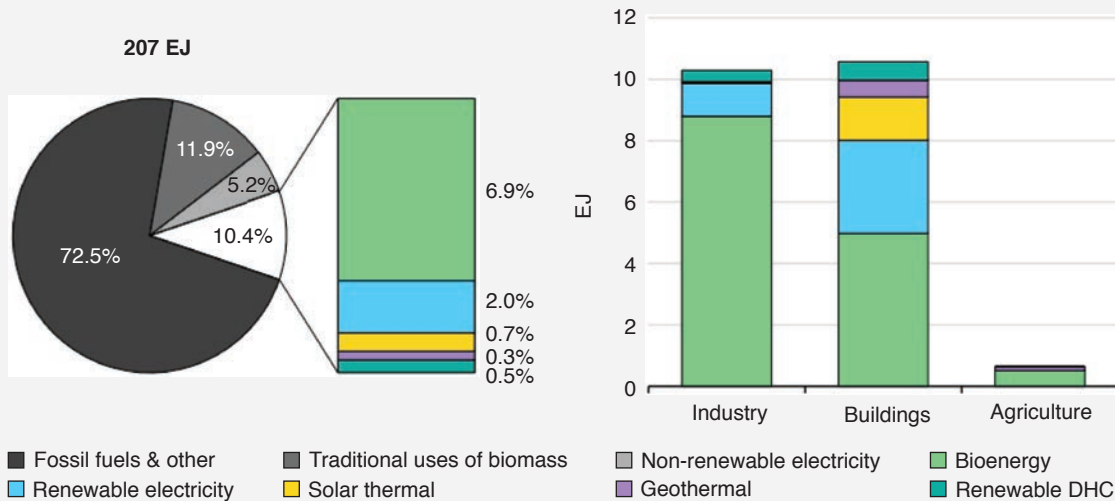

Source: IEA 2020a, 2020b.

Note: DHC = district heating and cooling; EJ = exajoule.

### BOX 1.1: GEOTHERMAL HEAT PUMPS

The geothermal heat pump, also known as the ground source heat pump, is a highly efficient renewable energy technology primarily used with resources at **very low temperatures of 5° to 15°C for heating and cooling** and in particular space heating and cooling. The technology relies on the fact that the earth (beneath the surface) remains at a relatively constant temperature throughout the year, warmer than the air above it during the winter and cooler in the summer, very much like a cave. The geothermal heat pump takes advantage of this by transferring heat stored in the earth or in ground water into a building during the winter, then transferring it out of the building and back into the ground during the summer. The ground, in other words, acts as a heat source in winter and a heat sink in summer. Electricity is required to power the compressor and additional equipment. Typical installations range in capacity from 5.5 to 150 kilowatts.

Source: US Office of Energy Efficiency & Renewable Energy n.d.(b).

### FIGURE 1.4: DIRECT USE OF GEOTHERMAL ENERGY WORLDWIDE, 1995–2020

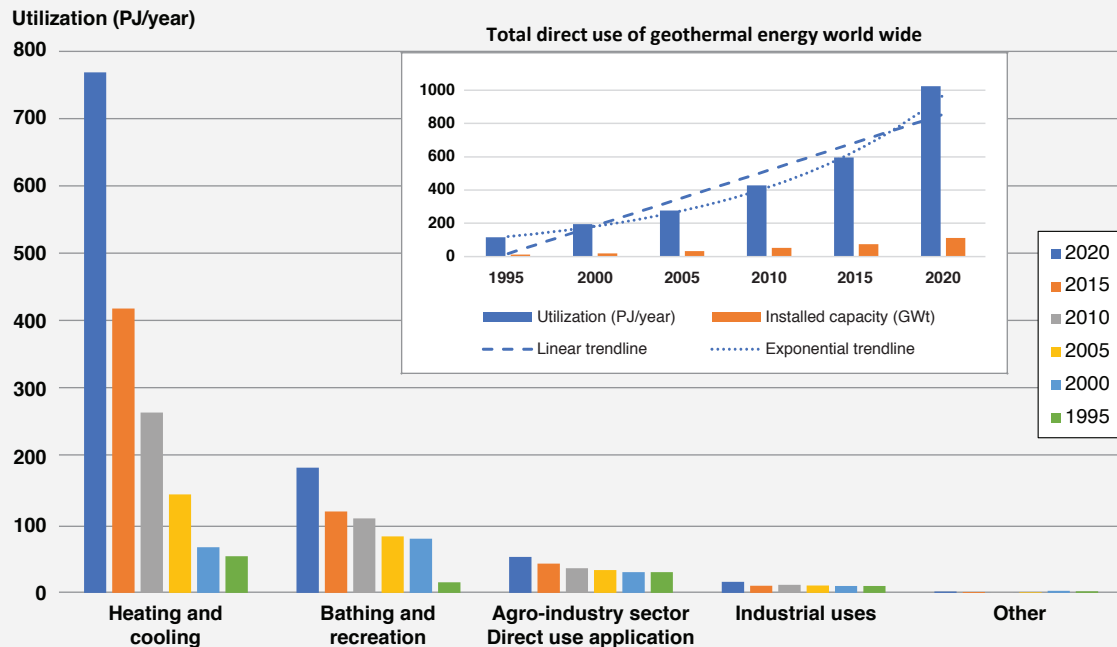

Source: Compiled from Lund and Toth 2020.

Note: Geothermal heat pumps, used usually for space heating, are also called ground source heat pumps. GWt = gigawatt thermal; PJ = petajoule.

Out of the 88 countries which report GDU, twenty-four countries account for 96 percent of installed capacity, and of those, only three are low- to middle-income economies (China, Turkey, and Ukraine). China, accounts for 40 percent of installed direct-use capacity.

Many countries are gifted with high-temperature geothermal resources and have utilized geothermal energy for electrical generation but have barely made any headway with direct use (for e.g., Indonesia, Kenya, Mexico, and the Philippines). To date the main has been space heating, which explains why countries with colder climates are more advanced in GDU adoption than other countries. Figure 1.5 shows geothermal electrical and thermal generation for the top 13 countries that produce geothermal electricity.

The limited uptake of GDU in countries that have geothermal power generation points toward certain barriers including: (1) limited familiarity with the resource; (2) challenges in matching resource location to the production process in which it is an input; and (3) relatively small-scale production facilities that limit interest and availability of capital from investors. However, as shown in this report, GDU technology is relatively simple. Economic activities that rely on heat as an input are ideal for the application of GDU and private capital markets are slowly realizing the monetary benefits of climate-friendly and resilient projects. These barriers and opportunities are discussed in section 4.

**FIGURE 1.5: GEOTHERMAL ELECTRICAL AND THERMAL GENERATION**

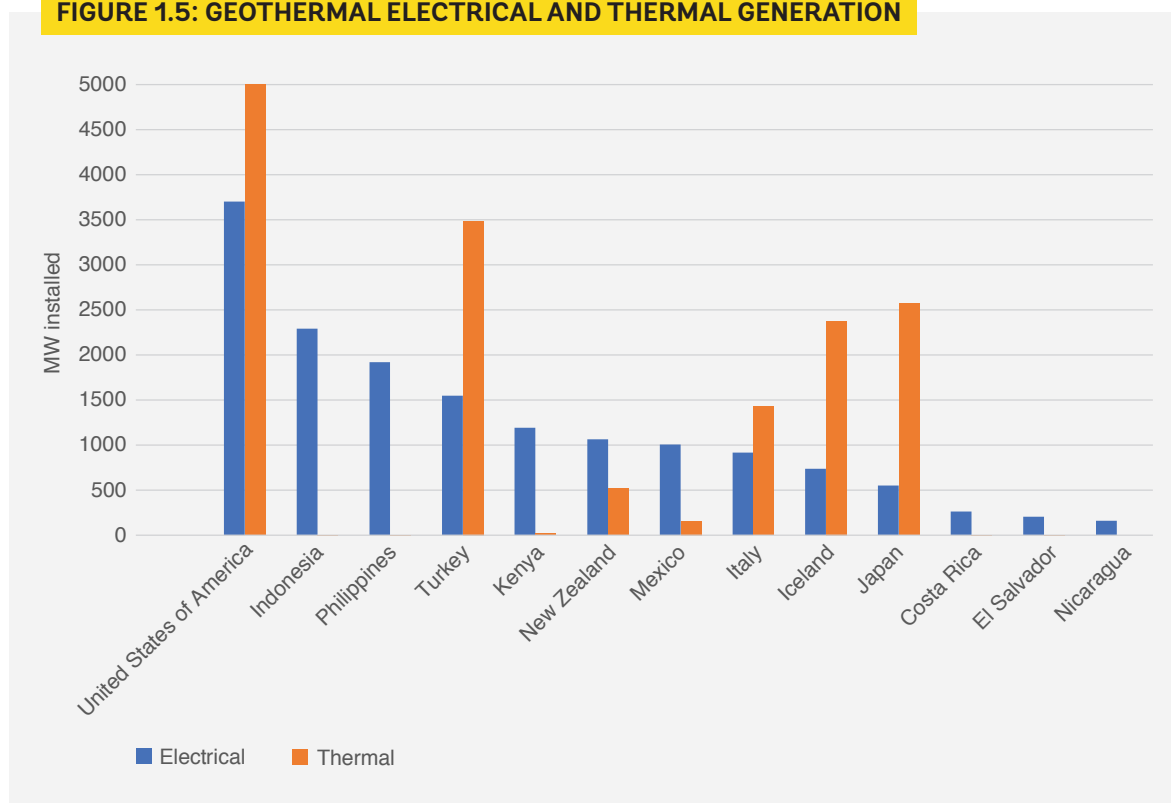

Source: Original calculations.

Note: MW = megawatt.

## SOCIOECONOMIC BENEFITS

Besides being a potentially low-cost heat source, GDU can deliver many socioeconomic benefits. To achieve climate targets, the heating sector must decarbonize rapidly (IEA 2021). However, progress in decarbonizing heat has been even slower than that of decarbonizing electricity where renewables like solar and wind are making necessary headway. GDU is one of the few technologies that may be financially viable against alternative carbon-intensive fuels for heat generation.

Beyond decarbonization, GDU provides multiple benefits that contribute more broadly to SDG 7 on universal access to affordable and clean energy as well as other SDGs, including poverty eradication, gender equality, mitigation of and adaptation to climate change, food security, health, education, sustainable cities and communities, clean water and sanitation, jobs, innovation, transport, and addressing refugees and situations of displacement (UN 2018). Figure 1.6 provides an overview of the key benefits and relevant key SDGs. How the key benefits of GDU connect to several of the SDGs is outlined in more detail below.

**FIGURE 1.6: GEOTHERMAL DIRECT USE AND SUSTAINABLE DEVELOPMENT GOALS**

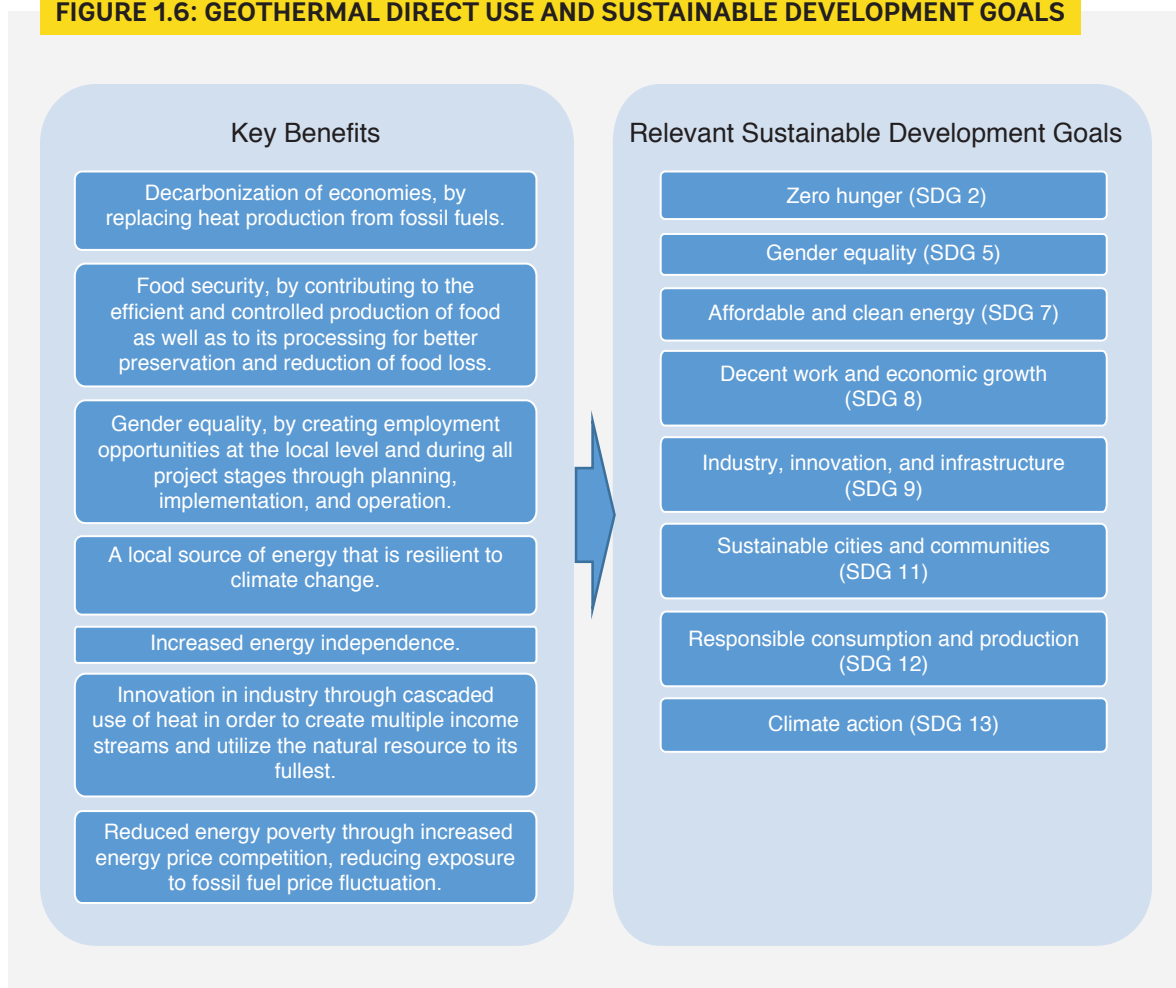

Source: Original compilation for this publication.



## Direct Utilization to Boost Food Production and Reduce Food Loss and Waste

### Sustainable Development Goal 2: Zero hunger

Energy is used at every step of the food supply chain, and the food sector as a whole is estimated to use 30 percent of the global primary energy supply (FAO 2011b). Extensive use of fossil fuels introduces further risks, especially in countries that rely on imported fuels and are subject to their price volatility, and those where the high cost of fuels leads to lower-quality food production and preservation (IRENA 2015).

It is estimated that one-third of annual food production is wasted in low- and middle-income countries. High energy prices is only one of the factors contributing to this. Energy supply disruptions are more likely where long transportation and distribution chains to the food sector exist. A lack of access to modern energy technologies limits opportunities to deliver food products efficiently and safely from soil to shelf (FAO 2011a).

Geothermal energy provides a heat source that can be utilized for various agri-food applications such as agriculture, fish farming, greenhouses, and food drying and processing. It provides stable, local, and renewable heat supply that can help lower energy prices, reduce exposure to international energy prices, and help deliver produce with less food waste. It can also aid in the halt of deforestation, as utilization of geothermal heat (e.g., for sterilization of soils and drying of produce) increases the amount of food that can be produced per square meter (m<sup>2</sup>) and thus reduces the amount of land needed (IRENA 2019).

As shown in Figure 1.5, greenhouse heating, aquaculture pond heating, and agricultural drying do not currently play a significant part in current global direct utilization of geothermal energy (IRENA 2019). However, the geothermal potential is still present, and organizations such as the International Renewable Energy Agency (IRENA) have acknowledged the need to increase awareness regarding the utilization of geothermal heat in the agri-food sector (IRENA 2019).

Section 2 considers the relatively common methods of geothermal heat utilization. Some development projects are investigating innovations such as food production with geothermal energy, including for algae and spirulina in Iceland and Italy (EGEC 2017), as well as cell-cultured meat production and integrated fish and vegetable production.

## Impact on Gender Equality

### Sustainable Development Goal 5: Gender equality

GDU, under the right circumstances, can advance gender equality by creating:

- Employment and entrepreneurship opportunities in GDU applications in energy, hospitality, food growing and processing, specialized services and industry, and engineering and construction.
- Employment and entrepreneurship opportunities in GDU development, to be part of the planning and implementation process for energy plans and projects as well as operations.
- Access to clean energy for space heating (while removing the health threats from indoor air pollution from burning coal or biomass for space heat), and reducing or eliminating the need to gather wood or other fuels.
- Facilities for care economy by providing childcare services.
- Safe space for women for decision-making during project design and implementation.

Depending on the country and culture, these opportunities to foster gender equality may be inherent to current practices or may need to be supported and encouraged by the government, international development organizations, financing institutions, developers, or other authorities. It is of the utmost importance that people in every sector become promoters of gender equality. At any rate, it is imperative that gender equality issues be addressed at the onset of development projects and not as an afterthought. This can be achieved by including women, women's advocacy groups, and other organizations within the community in decision-making processes and having tools to ensure accountability (additional recommendations on how to build gender equality into project development are presented in section 4).

An ESMAP report on gender equality in the geothermal energy sector (ESMAP 2019) sets forth various issues that need attention if gender equality is to advance in the geothermal energy project. Three main categories of risks and opportunities identified in the report are listed below and adapted to GDU (covered in more detail in section 3).

**Changes in land and natural resource use.** These relate to legal rights that may differ between women and men, according to cultural traditions; land acquisition and the ability to start or manage geothermal businesses; and the possible disruption of land use patterns and resource access to thermal waters when projects are created without consultation with stakeholders. The exploitation of land involves risks that affect women and men differently. The compensation provided for land usage will in most regions of the world benefit men more than women as land rights are disproportionately distributed to men. According to the World Bank Group's report "Women, Business and the Law 2020," two-fifths of countries worldwide limit women's property rights, when it comes to either direct ownership or inheritance rights (World Bank 2020).

Geothermal sites are often found in diverse sociological and ecological contexts, often featuring unique topography to which local populations may attach spiritual and cultural significance. For many of the world's indigenous peoples, geothermal sites are considered to have sacred and healing properties (ESMAP 2019). Women in the project-affected communities may also rely on access to hot springs to carry out their daily household activities.

**Changes to employment and economic patterns.** In most countries, women are less likely than men to be employed in industry, as either skilled or unskilled labor, and are disproportionately affected by the burden of unpaid work. However, women's share of the workforce in the renewable energy sector is somewhat higher, at 32 percent in comparison to 25 percent for the overall energy and mining sector. Education in technical sciences is, however, disproportionately low, with women being less likely to obtain such education and therefore related employment. In general, opportunities for women are considered to be greater in the GDU sector than in power production because of the variety of jobs that the GDU sector offers (see section 3). Innovative ways to utilize the geothermal resource for GDU applications include food supplement such as GeoSilica (see Box 2.11) and skin care products such as Blue Lagoon Skin Care (see Box 2.13). The Blue Lagoon employed more than 800 employees in 2019, 59 percent of which were women. The Ahuachapán power plants in El Salvador provide employment for dozens of women who use geothermal condensates for nursery irrigation and geothermal heat for fruit dehydration; these women are also employed as park rangers and are involved in reforestation efforts in surrounding fields (ESMAP 2019).

## Employment Opportunities

### Sustainable Development Goal 8: Decent work and economic growth

Direct-use applications in the geothermal industry create employment opportunities requiring diverse levels of skills and education in both the short and long term. The nature of the jobs created vary according to the

nature of the application as well as the stage of project development and operation, for example exploration is not needed for co-generation or geothermal heat pumps.

Short-term opportunities associated with the exploration, design, and construction stages differ from the long-term jobs created after operation has commenced. Short-term job creation is less dependent on end usage, and these jobs are grouped by project phases (see below), while the jobs created for the long term are listed for each type of operation or usage. It should be noted that the specialization required for short-term jobs is most often found in consulting firms or contractors with a proven track record and long-standing experience. Such specialized skills are seldom available locally, but it is considered important to make sure contracts build in knowledge transfer to create local expertise. This should include provisions for advancing gender equality.

### Short-Term Job Creation

- 1. Exploration Phase.** This phase involves the gathering of the scientific data needed to establish the necessary characteristics of the resource. The main tasks include gathering and evaluation of existing data, surface exploration, exploration drilling, a prefeasibility report, and an environmental assessment (Flóvenz 2012; IGA 2013). Other associated work encompasses future permitting, land compensation, and social issues. Roles include:
  - **Specialists:** Geoscientists, engineers, environmental specialists, and legal professionals
  - **Skilled workers:** Drillers, earthmoving crews (for access roads and drill-pads), and surveyors
  - **Other workers:** Various jobs involving documenting the environment for future monitoring, collecting information regarding land use and land ownership, and documenting gender disparity; miscellaneous service jobs to support the specialists conducting reconnaissance and surveys, such as security guards, drivers, assistants, cooks, and cleaners
- 2. Design Phase.** Once the resource parameters have been established, the planned utilization can be designed and procured. The exact tasks required will depend on the application in question, but feasibility reports and design services are common for most types of planned use (Flóvenz 2012). At this stage, roles required include:
  - **Specialists:** Geoscientists, engineers, economists/business administrators, quantity surveyors, procurement specialists
  - **Skilled workers:** Surveyors, secretarial assistants, drafters
  - **Other workers:** Security guards, drivers, and miscellaneous assistants
- 3. Construction Phase.** The extent and exact requirements for the construction phase are highly dependent on the application in question and its scale. However, most applications involve the following tasks at some scale: construction, production drilling, testing, commissioning, and training. The roles include:
  - **Specialists:** Engineers; construction managers; project managers; operators for training; and health, safety, and environment experts
  - **Skilled workers:** Surveyors; secretarial assistants; earthmoving operators; drillers; welders; carpenters; electricians; plumbers; steel workers; masons; and health, safety, and environment monitoring staff

- **Other workers:** Laborers; miscellaneous assistants; cleaning and cooking staff; drivers; and security guards

Once the application has been commissioned, operations can ensue. The long-term jobs involved in the different types of applications are listed below.

### Long-Term Job Creation

Long-term job creation is mainly linked to the operational activities utilizing the geothermal energy. While a geothermal project is cost intensive in its development phase and involves the creation of a large number of short-term jobs, such projects require relatively few operational staff compared to the investment cost. On the other hand, direct-use applications other than district heating tend to be more intensive in terms of the number of workers and long-term employment.

1. **Operation Phase.** The extent to which jobs are created in direct-use application cases depends on the type of application. Geothermal heat supply systems will require maintenance of the distribution system and various operational staff to ensure the continuity of heat supply, invoicing of various clients, and so on. There will also be indirect job creation, depending on the purpose of the application. A geothermal loop developed with the sole purpose of providing heat to greenhouses nearby might create fewer direct jobs than a geothermal district heating system providing heat to many end users. However, the jobs created indirectly at the greenhouse and across the entire production chain may be consequential. The same may apply to various applications that create indirect jobs. These indirect jobs are not exhaustively listed here. As an example, geothermal bathing facilities may include hotels or resorts with a large staff to support a broad range of hospitality services, or spas or rustic pools that require a smaller staff.
  - **Specialists:** Geoscientists; engineers; economists or business administrators; social scientists; specialists, depending on the type of application (e.g., food scientists); horticulturalists; aqua culturalists; and hospitality managers
  - **Skilled workers:** Secretarial assistants; welders; carpenters; electricians; plumbers; steel workers and masons; hospitality (hotel staff, system maintenance engineers, etc.); and childcare providers
  - **Unskilled workers:** Laborers; miscellaneous assistants; cleaning and cooking staff; and drivers

### Industrial Parks and Geothermal Energy

#### Sustainable Development Goal 9: Industry, innovation, and infrastructure

Industry, innovation, and infrastructure are integral parts of the direct utilization of geothermal energy. Geothermal industrial parks are recognized as an efficient way to scale up the use of a given resource flow. Globally, many industrial parks are now in operation, under development, or in planning phases near various geothermal power plants. They often share in common a quest to maximize the value of the resource, often in innovative ways, for operation of industrial applications and transport of goods.

The concept behind geothermal parks is that all streams used in the park should be utilizing the synergy between the different companies operating in the park. For instance, starting with waste heat at various stages of a geothermal power plant, the fluid can be recovered for cogeneration, depending on the technology selected and the characteristics of the resource used. This heat is often at temperature levels suitable for

various applications including space heating, agriculture, and agro-industry, but also for industrial uses and thermal bathing purposes, as presented in section 2. The companies forming the geothermal parks can have various inlet temperatures for their applications, and the outlet temperature of one application can be the inlet temperature of another.

The development of a geothermal park concept is, as with all geothermal energy utilization, highly dependent on the characteristics of the resource. There are many ways to implement combined utilization concepts, in a cascaded or an integrated manner.

Many examples of new applications utilizing geothermal energy and innovation are to be found in the agriculture, food production, or greenhouse industries. These include, for instance, the cell-cultured meat production of MESOKine (ORF Genetics), sustainable integrated fish and vegetable production utilizing geothermal heat (GEOFOOD project, 2021), and the drying of fruits and vegetables (e.g., in Turkey and Mexico) (see section 2 for more information on these projects).

A geothermal industrial park can further benefit from the chemical and gas content of the fluids used in the process. CO<sub>2</sub>, for instance, can be used in various food production or industrial applications. When harnessed from geothermal fluids, it must be separated from other gases. This has been done in Turkey for applications in greenhouses, in Iceland and Italy for algae farming, and for green fuel production by Carbon Recycling International in Iceland (see section 2).

An industrial park has the potential to harness all the different resources that can be extracted from a geothermal fluid, with various actors benefiting from one another. This can be seen in Figure 1.7, the schematic of a 106-hectare geothermal industrial park in Hellisheidi, Iceland, where the geothermal resource provides electricity, hot water, geothermal water (brine), cold water, and CO<sub>2</sub> to various companies.

**FIGURE 1.7: EXAMPLE OF A GEOTHERMAL INDUSTRIAL PARK: HELLISHEIDI, ICELAND**

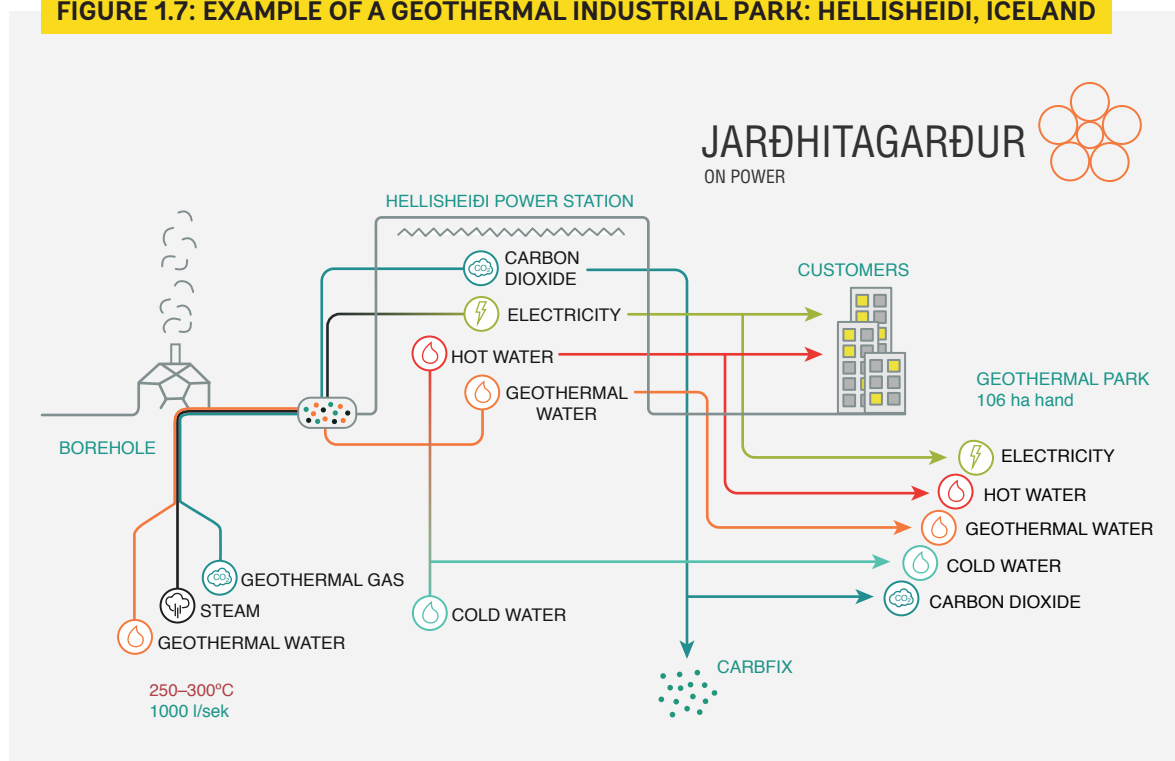

Source: Richter 2020a.

A geothermal industrial park in Kawerau, New Zealand, has industrial partners pioneering the use of geothermal process heat and geothermal clean steam technology for a pulp and paper mill that manufactures tissue paper, for a drying process of custom-cut lumber, and for dairy processing and pasteurization (Tuwharetoa Geothermal n.d.).

Geothermal projects have the possibility of achieving not only economies of scale but also economies of scope. Economies of scope describe situations in which producing two or more goods together results in a lower marginal cost than producing them separately. Economies of scope differ from economies of scale, in that the former involves producing a variety of different products together to reduce costs, while the latter involves producing more of the same good to reduce costs by increasing efficiency. Economies of scope can result from goods that are co-products or complements in production, goods that have complementary production processes, or goods that share inputs to production (GAMMA 2015).

### Clean Energy in Comparison to Heat Generation from Fossil Fuels

#### Sustainable Development Goal 7: Affordable and clean energy; 11: Sustainable cities and consumption; 12: Responsible consumption and production; and 13: Climate action

Geothermal energy is a clean energy source in comparison to fossil fuel alternatives. The energy resources that comprise renewables and waste heat for direct utilization are, as presented by IEA: industrial waste, primary solid biofuels, biogases, geothermal, solar thermal, and liquid biofuels. Figure 1.8 depicts heat generation by source globally from 1990 to 2017.

**FIGURE 1.8: HEAT GENERATION FROM RENEWABLES AND WASTE BY SOURCE GLOBALLY, 1990–2017**

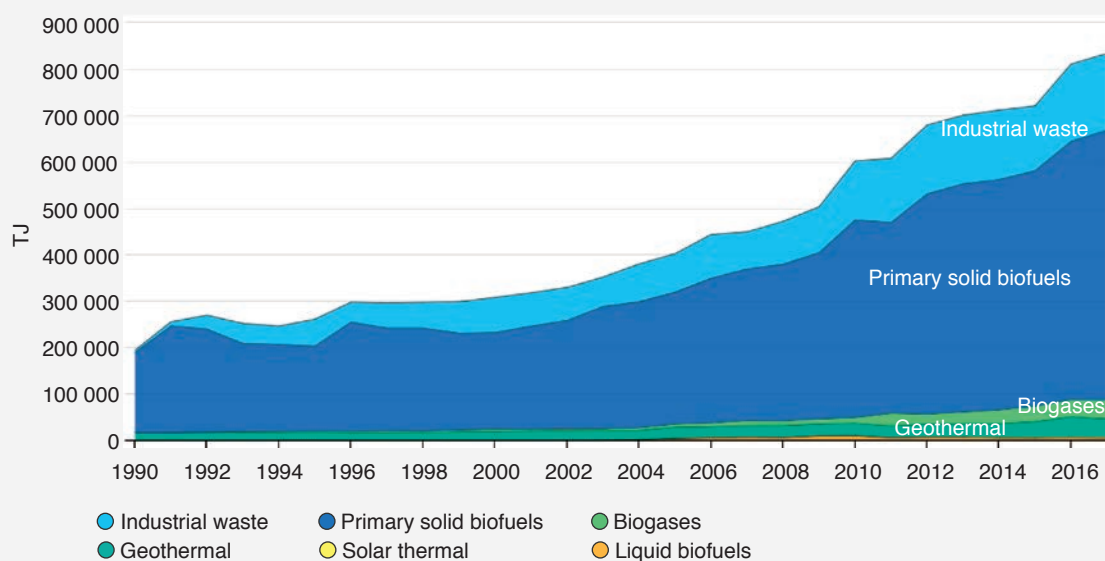

IEA. All rights reserved.

Source: IEA n.d.

Note: TJ = terajoule.

Figure 1.8 shows that geothermal resources are the third largest energy resource for heat generation within the renewables and waste category. Primary solid biofuels are by far the most used renewable energy sources; today these include firewood, peat, animal dung, as well as engineered fuel pellets. Industrial waste has also been growing in the past decade. Biogas is growing steadily while solar thermal and liquid biofuels still make up a very small share. Figure 1.8 does not include fossil fuels—natural gas, coal, and oil—which are still the primary energy resources for heat generation.

Heat accounted for 50 percent of global final energy consumption in 2021 and 40 percent of CO<sub>2</sub> emissions (IEA 2021). Heat is used for industrial processes, space heating, district heating, water heating, cooking, and agricultural greenhouse heating. Where it can be used, geothermal heating is a superior choice to heat generated by fossil fuels or electricity. Currently, the share of GDU in global renewable heat consumption is limited, as can be seen in Figure 1.8; it is, however, projected to increase by more than 40 percent by 2024, mainly in China, the United States, and the European Union (IEA 2019). Interest in the development of geothermal energy industrial parks also seems global and can be seen in efforts made by companies such as KenGen and GDC in Kenya; LaGeo in El Salvador; and in plans under serious consideration in Mexico, Costa Rica, Indonesia, and the Philippines.

The amount of hydrogen sulfide and greenhouse gases released in geothermal applications differs between geothermal fields, as the geothermal fluid varies from field to field with respect to gas content and totally dissolved solids. Most geothermal fields of the world are well within country emission limits and are considered cleaner than fossil fuel options. For direct utilization in low- and middle-temperature fields, the fluids often contain less greenhouse gases and totally dissolved solids than fluids accessed from hot-temperature fields often used for electrical power generation. Thus, direct utilization may release small amounts of gases into the atmosphere, depending on how fluids are utilized.

Direct-use systems in which the fluid is kept under pressure, such as when it is pumped to surface-based systems and reinjected within a closed loop, can be considered emission-free since the gases are dissolved within the fluid and reinjected without being released into the atmosphere. Thus, direct-use options can also have zero impact on CO<sub>2</sub> release.

## BOX 1.2: EXAMPLE OF ALTERNATIVE HEATING IN SWEDEN

The average CO<sub>2</sub> **emission** from GDU applications, are unavailable at the global level; however, some interesting comparisons have been made at a project level for fuel switching toward GDU.

This offers a comparison of CO<sub>2</sub> equivalents for heating across various fuel types using alternative heating sources for a refurbished single-family house in Stockholm (AEBIOM, EGEN, and ESTIF 2017).

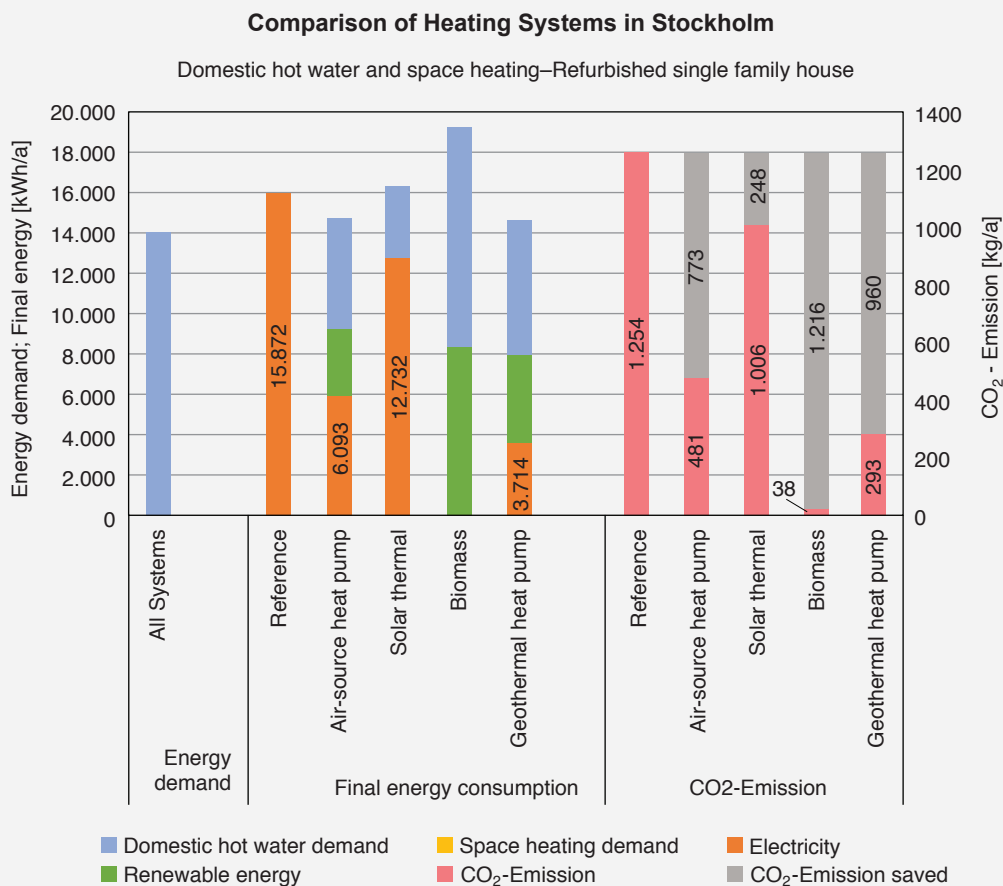

Comparison of all observed heating systems for domestic hot water and space heating preparation in new built multi-family houses in Stockholm. 📍

Source: AEBIOM, EGEN, and ESTIF 2017, 10.

CO<sub>2</sub> emission savings are considerable when using a geothermal heat pump and are better than results from the original reference case, which used an air-source heat pump and solar thermal. Note that in this example it is still assumed that the geothermal heat pump uses electricity derived from fossil fuels.



## 2. DIRECT USE APPLICATIONS: MATCHING RESOURCE TO MARKET

The selection of applications for GDU depends mostly on the temperature of the fluid, but chemical constraints and market potential play an important role in determining the feasibility of a selected application (see Figure 2.1).

A decision on which application to select should be based on a thorough market analysis to evaluate the demand, both internal as well as for export (as applicable); the in-country resources—for example, raw material and transport routes; and the ease of doing business in the selected country. A private developer will base their decision on profitability. When encouraging GDU, governments might look at the utilization from a different angle—for example, food security, diversifying the energy and decarbonization, employment, gender equality—in order to maximizing their socioeconomic benefits (see section 3).

For the purpose of this study, GDU is categorized by sector (see also Figure 2.1):

- Space heating and cooling
- Bathing and recreation
- Agro-industry
- Industrial uses

The following sections provide an overview of these application categories.

### SPACE HEATING, COOLING, AND DOMESTIC HOT WATER

The indoor climates of homes and buildings will follow daily and annual climate patterns unless houses are either heated or cooled. To ensure comfortable temperature conditions, space heating and cooling are sometimes necessary. Demand for space heating and cooling depends on the performance of a building's envelope (that is, the physical barrier between the exterior and interior environments enclosing a structure, including insulation and weather proofing) and on the local climate conditions. The building sector, encompassing both residential and commercial buildings, faces many challenges when it comes to meeting the SDGs related to accessibility and affordability of clean energy. Despite the implementation of programs aimed at retrofitting existing buildings to be less energy-intensive and the development of building codes for more energy-efficient buildings, the sector is still expected to continue as a large consumer of primary energy and is expected to grow immensely in the coming decades.

Although their use is difficult to forecast on a global scale, it is reasonable to expect that low- to medium-temperature geothermal resources suitable for direct use will be exploited in many places close to populated areas. For instance, in Europe about 25 percent of the urban population lives in areas where geothermal resources at temperatures above 90°C can be found at 1 kilometer (km) depth (Heat Roadmap Europe n.d.).

**FIGURE 2.1: POTENTIAL APPLICATIONS, DEPENDING ON TEMPERATURE OF THE GEOTHERMAL FLUID**

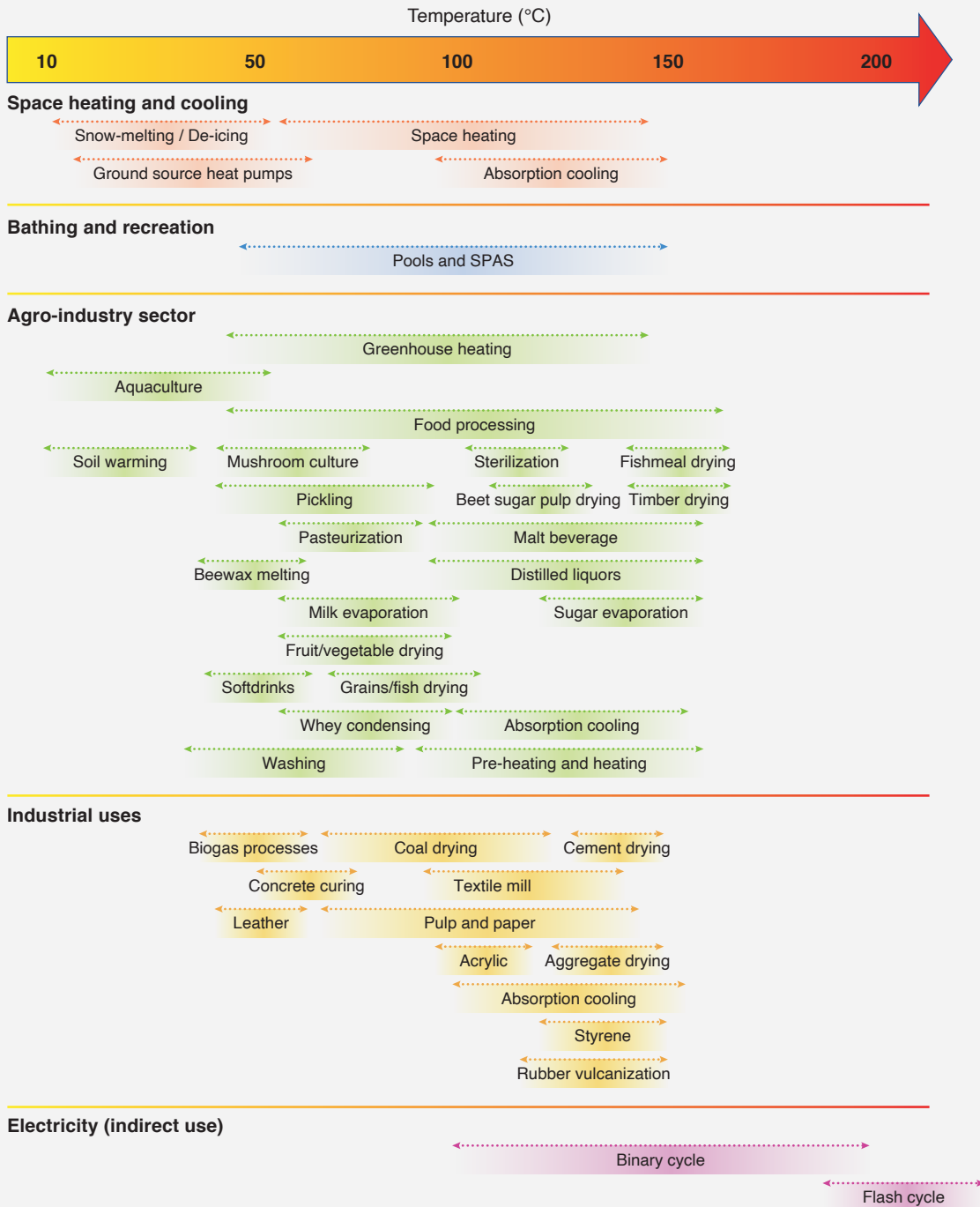

Source: Adapted from Lindal 1973.

The feasibility of geothermal resources for district heating systems has been proven in various countries such as Iceland (Box 2.1), China (Box 2.2), France, and Hungary. District heating can be implemented directly from a low- to medium-temperature field. Combined production, such as cogeneration with electricity production, has been showcased in Iceland, where the total installed capacity for space heating was 1,800 megawatts thermal (MW<sub>th</sub>) in 2020 (see Box 2.1).<sup>1</sup>

The globally installed capacity (Lund and Toth 2020) for space heating totaled about 13 gigawatts thermal in 2019 for an annual energy use of 163 PJ/year.<sup>2</sup> Overall, this corresponds to a capacity factor of 0.4—the annual energy output compared to the installed capacity—equivalent to 148 days/year, or about 3,546 hours' operating time at full capacity.

### BOX 2.1: GEOTHERMAL DISTRICT HEATING SYSTEM, REYKJAVÍK, ICELAND

The Reykjavík district heating system dates back to the 1930s, when visionaries realized the potential of the resource below their feet. The idea took time to sink in and gave rise to some debate, starting off slowly, house by house, street by street. Today, the Reykjavík geothermal district heating system is one of the most sophisticated in the world, using both medium- and high-temperature geothermal resources, with an installed capacity of about 2 gigawatts. In Reykjavík the summers are short and cold, and the winters are long, snowy, and windy. The temperature typically varies from  $-2^{\circ}\text{C}$  to  $14^{\circ}\text{C}$  and is rarely below  $-8^{\circ}\text{C}$  or above  $17^{\circ}\text{C}$ . According to the Icelandic National Energy Agency, geothermal district heating in Iceland has resulted in savings of up to 7 percent of gross domestic product per year relative to heating with imported fossil fuels, equivalent to \$3,000 per capita annually.

#### Reykjavik, Iceland in Winter



Photo credit: © Verkis. Used with permission.

<sup>1</sup> Energy data from the Iceland National Energy Authority (Orkustofnun n.d.), retrieved in April 2020.

<sup>2</sup> 1 petajoule = 1 quadrillion joules

## BOX 2.2: GEOTHERMAL DISTRICT HEATING, CHINA

Geothermal district heating is high on the government's agenda in the People's Republic of China, as it can contribute to the country's ambitious goals for carbon neutrality and improved air quality. Sinopec Green Energy Geothermal Development, a joint venture between Sinopec Star Petroleum and Arctic Green Energy, began to develop the geothermal district heating systems in China over a decade ago. They are currently operating district heating systems in seven provinces in northern China. Sinopec is the single largest developer and has approximately 35 percent market share. At the end of 2021, the heated area serviced amounted to approximately 60 million square meters and benefited 2.3 million people. It is estimated that by using geothermal energy, the system operator has avoided 1.3 million tons of standard coal use the same year and has reduced greenhouse gas emissions by 3.5 million tons of carbon dioxide, compared to a conventional system.

### District Heating Plant, China



*Photo credit: © Arctic Green Energy. Used with permission.*

While there are numerous district heating systems, there are relatively few geothermal district cooling systems, and these tend to be implemented on a small scale. A notable example is the geothermal absorption cooling unit running at the offices of Izmir Jeotermal in Turkey, with a cooling capacity of 210 kilowatts thermal and in Chena Alaska (Box 2.3). Ground source heat pumps are being installed to provide cooling as well.

In some cases, district heating systems offer flexibility to produce heat for both domestic water needs and for space heating. Space heating needs are primarily a function of weather conditions and building energy performance, whereas domestic water needs vary greatly on a daily basis, depending on users' washing patterns (e.g., baths, showers, laundry). When many buildings are connected to a district heating system, it is often economical to cover both space heating and domestic hot water needs with the same system.

District energy systems are centralized systems producing energy, heating, and/or cooling. Geothermal district energy systems usually combine wells, resource gathering systems, transportation and distribution systems, heat centrals, and peak load equipment to supply heating or cooling to a group of buildings (such as an office park, municipal area, or neighborhood). The energy is distributed to buildings in an area with an energy load density great enough to justify the installation of such infrastructure.

The distribution system consists of supply and return pipes connecting the heat central core to the end users. Heat losses in distribution may account for 5 to 20 percent of the produced energy, depending on the design and efficiency of the system. Heat losses are subject to the characteristics of each system, including local weather, distribution temperatures, piping characteristics, and insulation, as well as the linear heat density of the system (ratio of the annual heat delivered and the total length of the district heating piping and network).

Housing insulation (efficiency) and house heating systems in geothermal district heating systems are among the most critical components for utilizing a geothermal heat source. If geothermal heat is used in a house with existing heating systems that are not designed for the specific supply and return temperature of the geothermal resource, the resource will not be used optimally. Space heating needs are highly dependent on the local climate and the characteristics of the buildings. Old, poorly insulated buildings require greater installed power and consume more energy. Also, all buildings need ventilation to keep indoor air quality at an acceptable level. Recovering heat through the ventilation system helps keep energy demand as low as possible.

The outlet and inlet temperatures of conventional house heating systems, fueled with fossil fuels, are 70 to 90°C during periods of maximum heat use for an average apartment building. To be able to use low-temperature district heating systems, with a supply of 65 to 75°C, the overall size of a heating element must be larger. Implementing a geothermal district heating system in an old neighborhood with old existing hydronic systems almost always implies upgrading end users' space heating systems. Furthermore, the type of heating system used in houses should be carefully chosen according to the temperature level of the fluid provided by the district heating system. Large radiators or floor heating systems are commonly used for geothermal space heating, although air heating systems are also possible. A combination of radiators with supply/return temperatures of 75°C/35°C and floor heating systems can also be installed.

The typical net heat loss of a house is 1 watt (W)/(m<sup>2</sup> °C) in modern, highly efficient insulated buildings but can be as high as 2.5 W/(m<sup>2</sup> °C) in old, poorly insulated buildings. For instance, when the outdoor temperature is -15°C and indoor temperature is +20°C, the heat loss is 35.0 to 87.5 W/(m<sup>2</sup>°C).

With regard to cooling, district cooling distribution temperatures are 10 to 12°C for the supply side and 18 to 22°C for the return side, with a temperature difference of 8 to 10°C. A typical cooling load of a building is 19.5 to 32.5 W/m<sup>2</sup> when the outdoor temperature is +35°C and the selected indoor temperature is 22°C.

### **BOX 2.3: SPACE COOLING, CHENA HOT SPRINGS RESORT, ALASKA**

Chena Hot Springs Resort in Alaska uses geothermal for multiple purposes. Electricity is produced with a binary power plant using fluids at 74°C, which today is the lowest known geothermal resource temperature used for commercial power production. Geothermal energy is also used for a small district heating system serving 46 buildings. Finally, the Chena Hot Springs Resort has a museum made of ice called the Aurora Ice Museum, which is cooled with geothermal during the summer period with an absorption chiller.

*Source:* Lund 2006.

## AGRICULTURE AND AGRO-INDUSTRY SECTORS

The agricultural sector, including agro-industry (processing, packing of food), faces diverse challenges to feed humanity in a sustainable manner. Various trends—such as population growth, climate change, and economic growth, as well as conflicts, crises, and natural disasters—have impacts on food security and the overall sustainability of food and agricultural systems (FAO 2017).

This report classifies potential geothermal applications in the agriculture and agro-industry sectors in three categories:

- **Horticulture** is the science and art of development, sustainable production, marketing, and use of high-value, intensively cultivated food and ornamental plants.
- **Aquaculture**, also known as aquafarming, is the controlled cultivation of aquatic organisms such as fish, crustaceans, mollusks, algae, and other organisms of value such as aquatic plants.
- **Agro-industrial processes** are the methods used to further prepare food products for the market, such as drying or pasteurizing.

The agricultural sector requires energy at all food production stages: from primary production to postharvest and storage, processing, retail, preparation, and cooking (IRENA 2019). Industrialization of the sector and expansion of the food chain in the past decades have resulted in an increased energy demand for the sector. Fossil fuels remain the main source of energy, raising concerns about sustainability and operational expenses. The primary production is related to growing plants and raising animals (including horticulture, husbandry, aquaculture, and various other activities), whereas the other food production stages are related to agro-industrial processes. The sector uses a wide range of energy applications for its production and processing needs. Some of these applications are based on the use of heat that can be supplied via direct use of geothermal energy. Figure 2.2 shows the potential uses of geothermal energy in the agriculture and agro-industry sector.

### Horticulture

Geothermal resources are ideal for horticultural applications, especially where a large amount of low-temperature geothermal fluid is available for heating greenhouses, soil, and irrigation (if the fluid chemistry is appropriate). Thus, in horticulture, geothermal is not only a potential source of heat for growing crops (heating greenhouses or soil) but is also a potential source for irrigation; in addition, CO<sub>2</sub> extracted from the geothermal fluid can be used as a nutrient to enhance plant growth (see Box 2.4).

There are several methods to heat greenhouses: by circulating hot water in pipes or ducts below the floor, in units along the walls, or by heating air circulated in the greenhouse. Heating greenhouses is a rather energy-consuming activity; therefore, great care has to be taken during the designing. The selection of the construction materials and shape of the building will affect the investment cost and energy performance of the greenhouses. The typical heat loss is 7.5 W/(m<sup>2</sup> °C) in commercial greenhouses in cooler climates. This means that when the outdoor temperature is -10°C and the indoor temperature is +25°C, the heat loss is 262.5 W/m<sup>2</sup>.

The cultivation of various crops, such as tomatoes, mushrooms, cucumbers, paprika peppers, potted plants or flowers, and boutique herbs and vegetables can be optimized in a greenhouse environment, with a steady temperature enhancing plant activity and reducing condensation, which would otherwise lead to the development of fungi, mold, and harmful organisms.

**FIGURE 2.2: POTENTIAL USES OF GEOTHERMAL ENERGY IN THE AGRICULTURAL SECTOR**

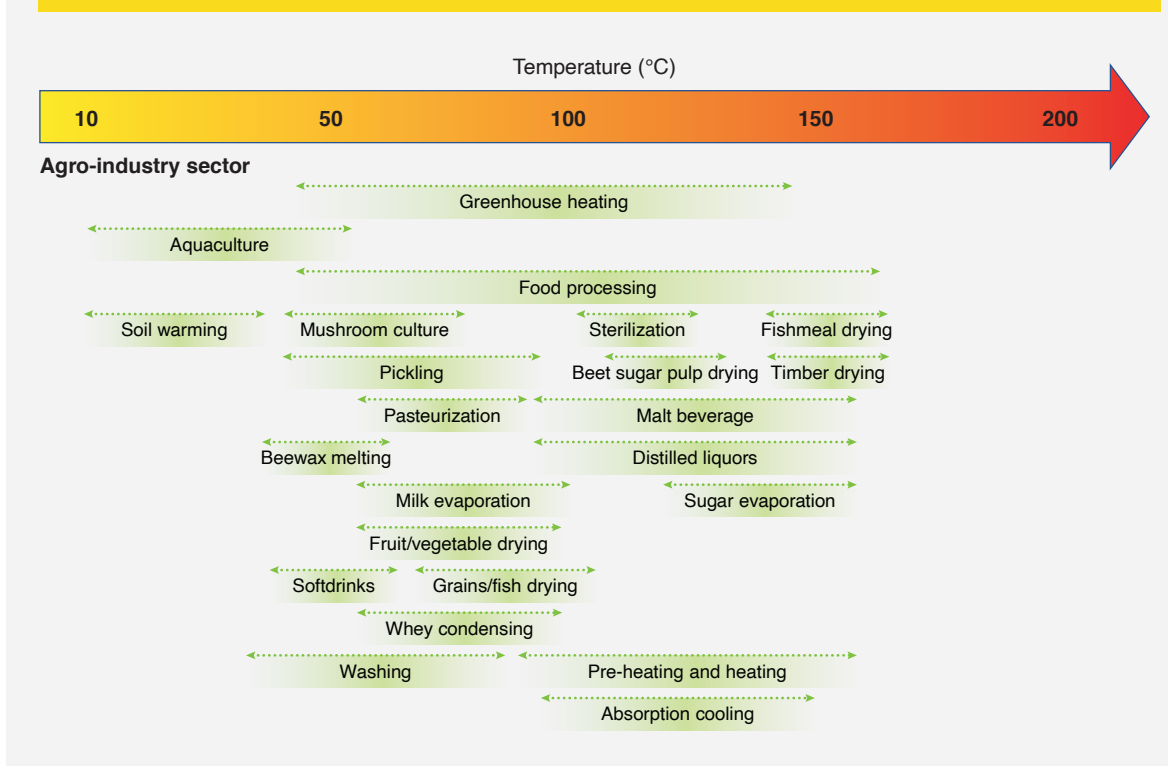

Source: Original compilation based on FAO 2015 and adapted from Lindal 1973

Direct use of geothermal heat is considered an especially interesting option for commercial greenhouse operations in cold climates with high heating requirements. In hot regions, the geothermal energy in greenhouses is used more for humidity control or to counteract the night cold in desert areas. The feasibility of the direct use of geothermal for horticulture should be assessed on a case-by-case basis depending on the characteristics of the resource, local weather conditions and market conditions, and type of crops cultivated. Geothermal water can also be used in open-field agriculture to keep the soil at a steady temperature. In practice, geothermal water is run through irrigation pipes in the ground, providing both heat and water to crops. This extends the production period and enhances production by keeping plants from being damaged in case of cold snaps or seasonal cold weather.

The rationale for the utilization of geothermal is that it is a reliable energy source that may reduce operating expenses; improve productivity and product quality through controlled temperature conditions; and improve market position with a positive image defined by a limited environmental impact and the use of a local sustainable energy source.

## AQUACULTURE

Aquaculture, or aqua farming, is the raising of aquatic animals such as fish, crustaceans, and mollusca, as well as aquatic plants such as algae and seaweed (Box 2.5). The most common species raised are catfish, bass, tilapia, sturgeon, shrimp, and tropical fish. One of the purposes of using geothermal resources for fish farming is to enhance the growth rate by creating stable and temperature-controlled environmental conditions.

#### **BOX 2.4: GREENHOUSE HORTICULTURE AT THE OSERIAN FLOWER FARM IN NAIVASHA, KENYA**

The Oserian Flower Farm is located close to the Olkaria geothermal field in Naivasha, Kenya, and was started as a vegetable-growing farm in 1969. In early 2000, Oserian initiated a major investment program to utilize geothermal energy in flower farming, and in 2003 the company went ahead and leased Well OW-101, one of the first wells to be drilled by Kenya Electricity Generating Company PLC (KenGen), to heat the greenhouses and supply CO<sub>2</sub> required for photosynthesis. KenGen is a publicly listed company today but was a state-owned company when Oserian began the project. The company was incorporated in 1954 under the Kenyan Companies Act as the Kenya Power Company and was mandated to generate electricity through the development, management, and operation of power plants. In 2006, the government sold 30 percent of its stake in the company following a successful initial public offering. Subsequently, KenGen was listed on the Nairobi Securities Exchange (KenGen n.d.).

Today, Oserian is one of the largest flower producers in Kenya, with a total of 50 hectares of greenhouses dedicated to roses sold to flower shops. The farm utilizes steam to produce electricity, steam, and brine to (Mangi 2017; Mburu 2014):

- Heat up the greenhouses and control humidity during the night (which is important to mitigate fungal infections and thus limit the use of chemical fungicides).
- Sterilize water used in the hydroponic system to reduce fertilizer waste.
- Enrich the indoor air with CO<sub>2</sub> to enhance the photosynthesis process.
- Fumigate the soils.

The electricity produced is also used in the post harvesting process, to precool the flowers before they are transported to the market.

The farm has over 2,000 employees, about half of which are women. According to Oserian, benefits extend beyond those of direct employment to include increased access to water for local communities (with Oserian having funded the drilling of boreholes away from Lake Naivasha), and livelihood opportunities, such as the making of bracelets by local Maasai and Kikuyu women (these are sold with flower bouquets, with profits going directly to the women).

The cogeneration is an example of private and public partnership between the Oserian Development Company Limited (ODCL) and KenGen in Kenya.

*Source:* Richter 2019; HortiNews 2018.

The use of geothermal resources in aquaculture depends on the type of aquatic animals raised and the required quality and composition of the water used. The geothermal fluid can in some cases be used directly or mixed with freshwater to obtain the optimized temperature in the pond or pool. Heat exchangers might be required if the chemical composition of the geothermal fluid is unsafe for the aquatic animals or if reinjection into the reservoir is planned. A typical process for using geothermal energy in seawater fish farming is shown in Figure 2.3; freshwater fish farming would have a similar setup.

The European GEOFOOD project investigates viable agri-businesses that can add an income stream to geothermal heat installations (GEOFOOD Project 2020). A research plant was constructed in the



## BOX 2.5: MICROALGAE PRODUCTION, SAGANATURA, ICELAND

Microalgae are a source of nutrients, proteins, lipids, and fibers from the bottom of the food chain. To grow, these organisms mainly need CO<sub>2</sub>, light, micronutrients, and water. Microalgae are thought to play an important role in providing food for humans and animals. They are sustainable plants that utilize and absorb CO<sub>2</sub>, emit oxygen, and use minimal amounts of water and land compared to traditional food and feed production. SagaNatura, an Icelandic firm, has developed a patented technology to cultivate microalgae and currently cultivates them for the supplement industry. The company uses geothermal resources in its process and is starting to use CO<sub>2</sub> from a local industry that has a large carbon footprint.

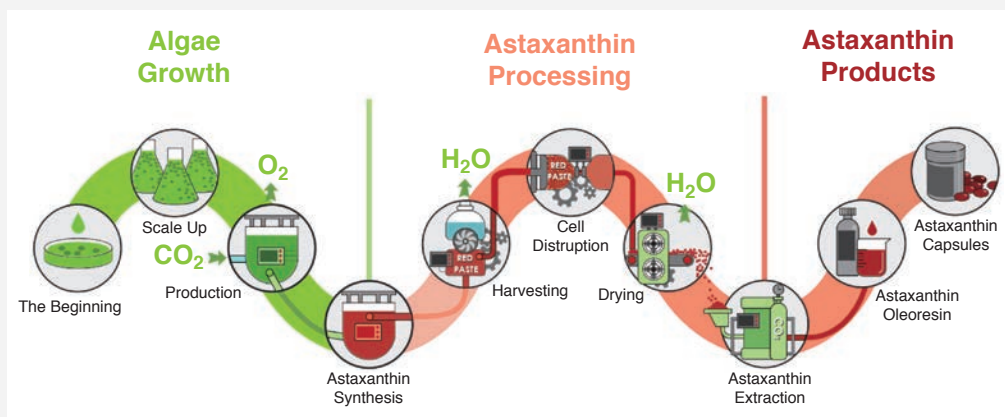

Source: Guðmundsson 2016; IRENA 2020a; KeyNatura n.d.; Kjalarsdóttir 2018.

Note: CO<sub>2</sub> = carbon dioxide; H<sub>2</sub>O = water; O<sub>2</sub> = oxygen.

## FIGURE 2.3: PROCESS OF SEAWATER FISH FARMING USING GEOTHERMAL RESOURCES

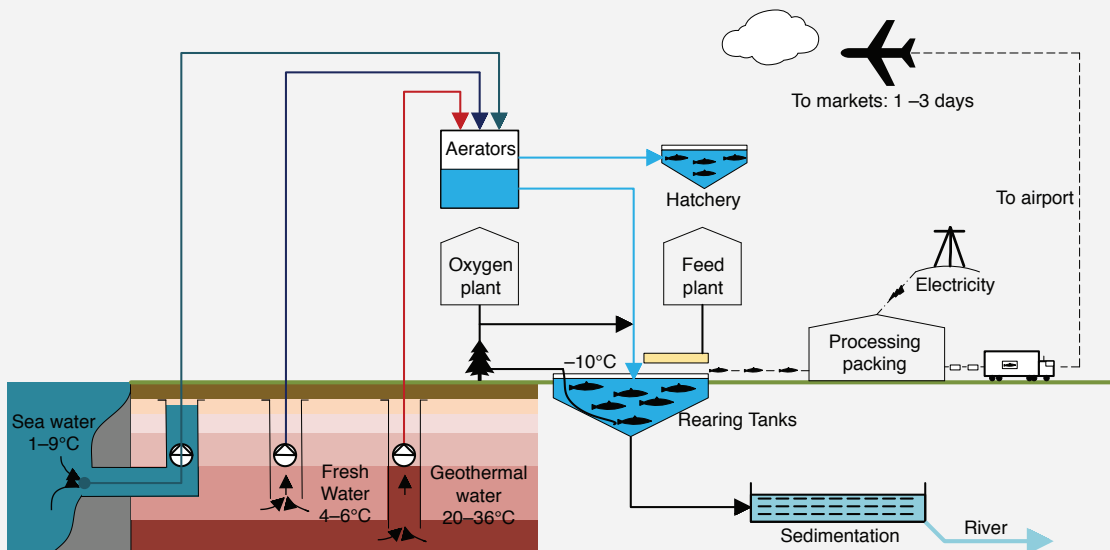

Netherlands and a demonstration plant in Iceland to validate and demonstrate sustainable integrated fish and vegetable production utilizing geothermal heat (Figure 2.4).

### Agro-industrial Processes

Food processing plays an important part in reducing postharvest losses and ensuring that the food produced is safe for consumption. As shown in Figure 2.3, geothermal resources can be used in diverse processes including drying, pasteurization, sterilization, evaporation, and distillation.

**Drying.** The drying of agriculture products is an important food preservation process and contributes to food security in many countries. Drying was one of the first methods used for food preservation and is still used widely to produce stable, safe, and easily transportable products that can be kept at a moderate temperature.

**FIGURE 2.4: SCHEMATIC DIAGRAM OF A DECOUPLED AQUAPONIC SYSTEM**

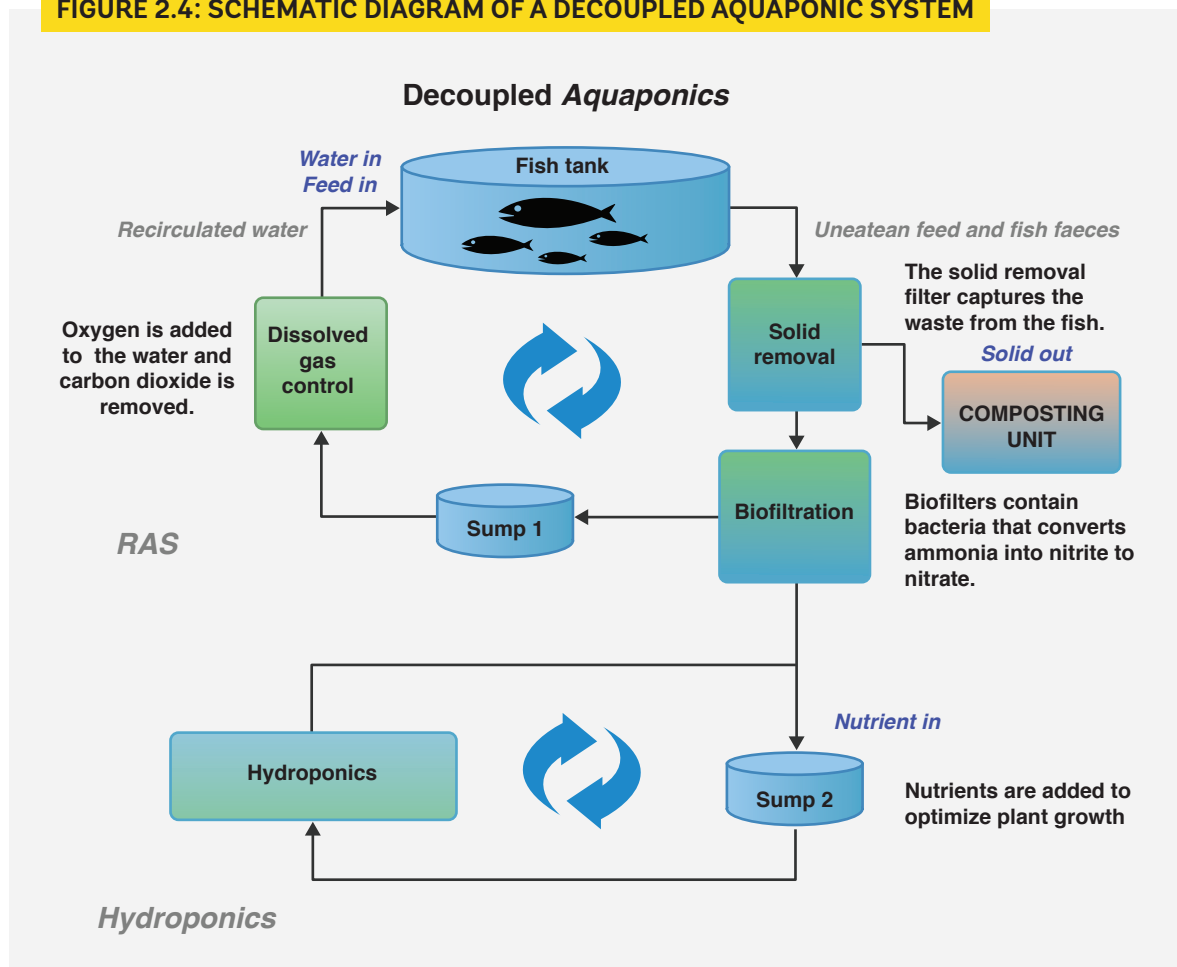

Source: GEOFOOD Project 2020, Figure 4.

Several countries use low- to medium-enthalpy geothermal resources for food drying. In Greece, a facility uses geothermal hot water at 59°C for drying tomatoes; it can process 175 kilograms (kg) in 45 minutes. In Thailand, waste heat from a geothermal power plant is being used to dry chilies and garlic. In North Macedonia, rice is being dried using hot water from a geothermal well with a capacity of 10 tons/hour. The temperature of the inlet and outlet are 75°C and 50°C, respectively. In Indonesia, geothermal waste fluid is used to dry beans and grain. In Nevada, United States, there is a large-scale facility for drying garlic and onions with a capacity of 500 to 700 kg/hour. In Iceland, geothermal heat is used in various drying processes, such as for fish (see Box 2.6). In another example from western Iceland, seaweed is dried in a continuous geothermal drier. The geothermal fluid used is around 110°C and leaves the factory at 55 to 60°C. The waste heat from the seaweed facility is then utilized to evaporate seawater to produce high-quality salt flakes for consumption.

### BOX 2.6: FISH DRYING, ICELAND

Iceland dries about 20,000 tons of cod heads and other fish products per year. This drying has been successful and is divided into two stages: primary drying and secondary drying. The primary drying is carried out in a batch tunnel dryer or in a specially designed continuous conveyor dryer, and the drying time in this step is 24 to 40 hours, at which time the weight of the raw material has reduced by 60 percent. The optimal conditions of the drying air are a temperature of around 18 to 25°C, relative humidity of 20 to 50 percent, and air velocity of about 3 meters per second. Secondary drying of semidried products is done in drying containers of 1 to 2 cubic meters volume with hot air blown through. The optimal conditions are an air temperature of 22 to 26°C, humidity of 20 to 50 percent, and air velocity in a full container of about 0.5 to 1 meter per second. The water content of the end products after drying is less than 15 percent, which is achieved in about three days in the drying container.



Source: Arason 2003.

During the drying process, some physical, chemical, and biological changes may alter the food's quality and nutritional value. The product being dried and its intended use are what determine the heat level applied in the process. In fish drying, the heat must be low enough to avoid the denaturation of proteins, a process that occurs at less than 28°C for cold water fish but higher for fish in warmer, tropical water. In grain drying, the air temperature depends on the grain use. Seeds should be dried at a temperature just below 40°C, grain for milling under 60°C, and grain for animal feed can go up to 80°C (Kinyanjui 2013).

In 2020, Kenya produced around 4 million tons of maize. The Rift Valley accounts for around 70 percent of the national production. Although the main geothermal sources in Kenya are also located in the Rift Valley, the industrial-level grain drying is driven by fossil fuels, but at the small-farm level, sun drying is still a common practice.

Based on the assumption that the energy required for evaporating 1 kg of water in the drying process from a substance is about 5,800 kilojoules (kJ), calculations indicate that the energy cost for drying grain with dryers using diesel oil can be up to 18 times higher compared to using geothermal energy. Similar calculations comparing electrical dryers to geothermal dryers indicate more than a 20-fold higher cost for electrical dryers (see Figure 2.5). The carbon footprint is clearly smallest for geothermal energy; other energy sources, particularly firewood, release far more carbon (with around 70 times more CO<sub>2</sub> emissions compared to geothermal energy).

A great variety of food is dried using a thermal drying process, mainly for preservation purposes. These include, but are not limited to, fruit and vegetables, fish, coffee and cacao beans, and tea. It should be noted that current dryers that run on oil, electricity, firewood, or other energy sources can easily be converted into geothermal dryers if geothermal sources are available.

**FIGURE 2.5: COMPARISON OF COST AND CO<sub>2</sub> EMISSIONS AMONG DIFFERENT ENERGY SOURCES FOR DRYING GRAIN**

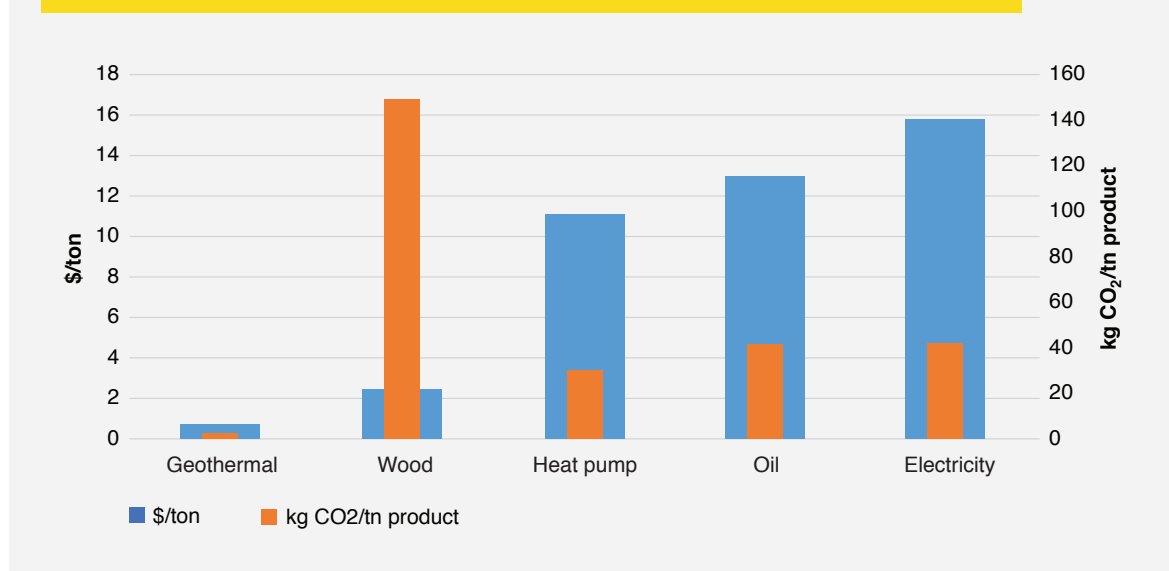

Source: Gissurarson and Georgsson 2015.

Note: kg CO<sub>2</sub> = kilograms of carbon dioxide.

## BOX 2.7: INDUSTRIAL FOOD DEHYDRATOR, NAYARIT, MEXICO

The first industrial-grade dehydration facility in Latin America has been set up at Domo de San Pedro in Nayarit, Mexico. The project is led by iiDEA, PI INGENERA, and Grupo Dragón, with support from the Mexican federal government and the World Bank. The food processing plant uses hot geothermal water from the Domo de San Pedro geothermal power plant (operated by Grupo Dragón) before reinjection into the geothermal reservoir.



*Photo credit: © Dr. Héctor Miguel Aviña Jiménez. Used with permission.  
Further permission required for reuse.*

Currently mangoes, pineapples, tomatoes, and jackfruit are dehydrated at the plant, which can process any kind of food. The plant surface is 2,000 square meters, and it will generate up to 50 local jobs (80 percent for women) as well as indirect employment for about 60 people in the region.

*Source: Richter 2020b.*

**Pasteurization** is a partial sterilization process in which heat is applied to food and beverages to destroy all vegetative pathogens and reduce enzyme activity to prolong shelf life. Pasteurization aims at providing a 6-log reduction of the most heat-tolerant pathogenic target organism. In the milk industry, the target organism is *Coxiella burnetti*, and in other food it is usually *Listeria monocytogenis*. These two pathogens have similar heat tolerance.

In milk pasteurization, various time and temperature profiles are used (see Box 2.8). The most common are:

- 72°C for 15 seconds (high-temperature, short time process)
- 63°C for 30 minutes (vat or batch pasteurization)

As pasteurization aims to kill the most heat-resistant pathogen, other pathogens will die, as well as many other bacteria present in the product, including many spoilage bacteria. Some bacteria may survive the heat treatment, especially if their initial count is high; however, they will not, multiply if the milk is kept at a proper refrigeration temperature.

Acidic food or food that has a pH less than 4.6 can be stored at a moderate temperature after pasteurization, as the bacteria and endospores that can survive the heat process will not be able to grow or germinate at such a low pH. This includes most fruit juices and marinated products.

Pasteurization is applied in various food processes, such as in cooked shrimp manufacturing where steam or hot water is used to heat the shrimp to a core temperature of 72°C for 18 seconds or equivalent. In the production of imitation caviar, the product, packed in a glass jar, is conveyed through 80°C water to eliminate *L. monocytogenis*. This last method can also be used for pickled vegetables and other products to prolong their shelf life and storage stability. A study of the cost of using geothermal energy for milk pasteurization compared to fossil fuels (diesel) was conducted in Kenya and presented at the 7th ARGeo conference in 2018. The report indicated that the thermal energy cost is lowered by 77 percent if geothermal energy is used instead of diesel in pasteurization (Bernard and Kiruja 2018).

**Sterilization** can be completely obtained by heating a substance to 121.1°C for 15 minutes. This heat profile is used in hospitals and laboratories as required. In the food industry, sterilization processes aim at reducing the spores of the most heat-resistant pathogen, *Clostridium botulinum* (which causes botulism), or the spores of that bacteria. The target heat profile is 121.1°C for 2.52 minutes or equivalent. This heat treatment is called commercial sterilization.

Microbial spores are dormant and are very heat tolerant. In favorable conditions, the spores can germinate to become living microorganisms and start to multiply. *Clostridium botulinum* can produce a lethal toxin if they reach a certain number. Some *Bacillus* spores may survive commercial sterilization, like the spores of *Bacillus stearothermophilus*, which can germinate in tropical conditions and start growing. Although the bacteria are not pathogenic, products produced for the tropical market receive higher heat treatment if the product is to be stored over 25°C.

In the canning industry, the products are normally not heated to 121°C; a lower heat and longer duration are used. The temperature profile used is typically 112 to 115°C for 20 to 30 minutes; this profile is easier to control and therefore ultimately increases the quality of the product.

For a long shelf life, milk and other low-acid liquids require a high temperature of 140°C for 2 seconds or the equivalent, which normally achieves commercial sterilization. This high temperature for a short duration is accomplished in a plate heat exchanger, and the liquid then is packaged aseptically.

**Evaporation** is used in the food industry to produce a concentrate by heating a liquid to the boiling point to remove water as vapor. A typical evaporator consists of a heat exchanger that is enclosed in a large chamber, which then transfers heat from a heating media (usually steam) to the product being processed. The temperature difference between the heating media and the product is the driving force for heat transfer. If the temperature of the heating media is too high, fouling or burn-on increases on the surface of the heat exchanger, which limits how high the temperature of the heating media can rise. In some evaporation processes, like the production of flake salt, the evaporation is conducted at a temperature below the boiling point or at around 60°C.

For heat-sensitive products, the boiling point of the product is reduced by producing a partial vacuum in the evaporation chamber. In the production of condensed milk, for instance, the boiling point of the milk is reduced to 40°C and concentrated to 30 to 40 percent solids.

Evaporation is used in various food processes, including the production of tomato paste, jams, syrups, and salts; the processing of various fruit concentrates; and in the dairy industry (e.g., condensed milk).

**Distillation** is a process whereby liquid is separated by vaporization and recondensed by cooling the vapor. The separation is based on the different boiling points of a mixture. In the food industry, distillation is mainly used in the production of essences and alcoholic drinks. As with evaporation, the boiling point of different compounds can be adjusted by lowering the pressure in the distillation chamber. Vacuum distillation can be important in the production of sensitive aromas and essences, as too high of a temperature can affect the quality of the product.

The temperature required for distillation and evaporation varies depending on the product being processed and the processing method applied. Common operating temperatures are typically 80 to 120°C.

## INDUSTRIAL USES

Industrial applications encompass a wide range, requiring fluid at low, medium, and higher temperatures to preheat, wash, evaporate, distill, separate, dry, or even chill (via heat pumps or absorption coolers). Many industrial processes can utilize geothermal as their heat source in their process with minor modification. A typical temperature range for various industrial applications is shown in Figure 2.6.

### BOX 2.8: PROCESSING MILK USING GEOTHERMAL RESOURCES: MIRAKA, NEW ZEALAND

Miraka is a majority Maori-owned (Tuaropaki Trust) dairy-processing company in New Zealand. It processes milk from 100 local farms within an 85-kilometer radius. The process capacity is around 300 million liters of milk each year, producing milk powder, ultra-high-temperature (UHT) milk, specialty milk powder, and frozen milk concentrate. The company exported its products to more than 26 countries.

The Tuaropaki Power Company (75 percent owned by Tuaropaki Trust) operates two geothermal power plants with 110 MW capacity; in addition to the dairy farm, the company also operates greenhouses that produce tomatoes and capsicum for export. The Miraka dairy farm receives steam from the power plant, and waste heat from both the dairy farm and the greenhouses is used to grow native plants.

*Source:* Miraka n.d.

**FIGURE 2.6: TEMPERATURE RANGE FOR COMMON INDUSTRIAL PROCESS APPLICATIONS**

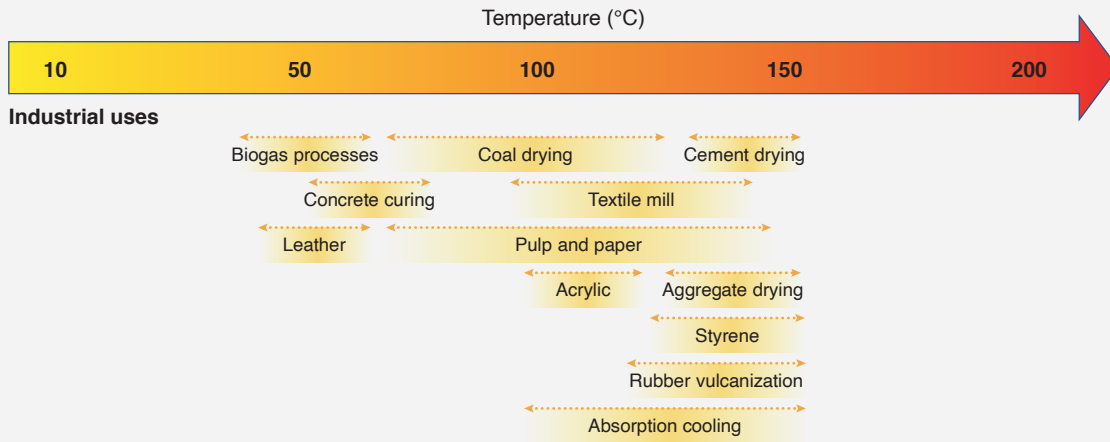

Source: Adapted from Lindal 1973.

Typical processes involved in the industrial uses of geothermal resources are in some cases similar to those used in the agro-industry sector:

- **Drying** can be achieved by using air preheated by the geothermal fluid via a heat exchanger or by direct contact. Such a process is similar to the one used for drying crops or fish as previously described. Natural air-drying of timber is a slow, inexpensive process that can be enhanced by using timber-drying kilns. Kilns function like large ovens in which heated air is circulated to remove moisture from the timber. Hot air is produced with hot water supplied by heat exchangers.
- **Evaporation** is used to concentrate solutions. It is used, for instance, to obtain salt. The process is also used for water desalination or in any process requiring the vaporization of a solute.
- **Distillation** is the process of separating mixtures based on differences in the volatility of components in a boiling liquid mixture.
- **Refrigeration** is possible with absorption heat pumps that use a lithium bromide solution to convert geothermal heat into a source of industrial cooling or freezing.
- **Process heating** can be achieved by preheating water in a boiler or with direct heating (e.g., for washing and dyeing, baking) (see Box 2.10).
- **Industrial space air conditioning** may be part of the industrial process in a specific plant where the process requires given temperatures or the use of ground source heat pumps.
- **Other processes** can be used, such as the extraction of minerals (such as silica, sulfur, gases, salts, lithium, or other precious metals) and gases (see, Boxes 2.9, 2.11, and 2.12) from the geothermal resource.

The use of geothermal resources for industrial applications might, however, require adapting or retrofitting existing solutions. Equipment selection might be affected by geothermal fluid chemistry and components



## BOX 2.9: UTILIZATION OF CO<sub>2</sub> FROM GEOTHERMAL RESOURCES, ICELAND

In Svartsengi, Iceland, Carbon Recycling International utilizes CO<sub>2</sub> from the adjacent HS Orka Svartsengi geothermal power plant. The CO<sub>2</sub> stream from the power plant is purified by removing sulfur compounds as part of the production process to make it suitable for downstream methanol synthesis. After gas mixing and stepwise compression, the gas mixture containing hydrogen generated by electrolysis of water and CO<sub>2</sub> is catalytically reacted to convert it into methanol and water. The final step involves removing the water content with a distillation process using geothermal steam.

The renewable methanol or e-methanol produced at the plant has been sold in the UK, Sweden, the Netherlands, and Iceland; it has been used in being blended with gasoline, in the production of biodiesel, for wastewater treatment, and in other chemical applications. The technology is currently being implemented in other industries and other countries for the reuse of industrial carbon emissions.

### Carbon Recycling International Production Plant



Source : Carbon Recycling International n.d.

Carbon dioxide can also be used to support greenhouse agriculture. For example, in Turkey, CO<sub>2</sub> with a purity level of 95 percent or higher is obtained from the Kızıldere-I, Dora-I and Dora-II geothermal power plants; after being processed on-site, it is supplied for various applications in industry and agriculture.

Source: Aksoy et al. 2015.

such as silica, oxygen, chlorides, calcium, magnesium, hydrogen sulfide, and the pH. Deposits (calcite, sulfides, silica) are not expected to be a major problem in low-temperature utilization compared to high-temperature utilization. A common solution is to keep the geothermal fluid in a closed loop and generate heat through heat exchangers. However, depending on the geothermal field characteristics and the industrial application, the socioeconomic benefits of using such a source of energy may be higher than the cost of adaptations that are required to utilize the resource.

#### BOX 2.10: THE RITTERSHOFFEN HEAT PLANT, FRANCE

The Rittershoffen geothermal heat plant in the north of Alsace, France, has an installed capacity of about 25 MW<sub>th</sub>. The closed-loop geothermal system gathers 165°C water at a depth of 2,500 meters and can supply 190,000 MWh<sub>th</sub>/year, covering 25 percent of the process heat needed at the Roquette Frères industrial site in Beinheim, located 15 kilometers from the well site. The company specializes in processing plant-based raw materials into products for pharmaceutical use, nutrition, food, and other select markets. The utilization of geothermal heat is expected to contribute to an annual reduction of CO<sub>2</sub> emissions by 39,000 tons.



*Photo credit: Creative Common License, <https://www.flickr.com/photos/geothermalresourcescouncil/29215632814>.*

The geothermal supply is combined with a fuelwood biomass boiler and an installation to produce biogas. The advantage of geothermal in this case is its availability, about 8,000 hours a year, providing Roquette Frères with a secure source of energy at a controlled cost.

*Source: Roquette n.d.*

## BOX 2.11: GEOSILICA, ICELAND

GeoSilica, an Icelandic start-up company, has developed the GeoStep® production method to extract and purify minerals for the production of natural-silica-based food supplements from the geothermal water from the Hellisheiði geothermal power plant. In 2015 GeoSilica launched their signature product, Pure, which is 100 percent natural silica. Pure has experienced an approximately 50 percent increase in annual sales growth in Iceland. Today GeoSilica has four new products: Renew, Recover, Repair, and Refocus. All of GeoSilica's products have a base of natural silica combined with other minerals and vitamins. GeoSilica employs seven employees, five of which are women.

Source: GeoSilica: <https://geosilica.is/>.



## BATHING AND RECREATION

Areas with geothermal features, from volcanoes to thermal springs, are attractive for leisure and tourism. Such places are attractive not only because of their geothermal resources but also because of their topography, climate, and biodiversity. Geothermal bathing and swimming facilities have long been established in local cultures, some since ancient times. Existing facilities can be upgraded, or new ones developed, for therapeutic and recreational purposes; these facilities contribute to diversifying the recreational and geotourism activities in select areas.

Geothermal resources can be used directly for bathing and swimming, as is the case in hot spring resorts which use hot water fed from self-flowing springs. Drilling is sometimes necessary to gain better access to the resource. Geothermal fluid often holds dissolved minerals, some known for their potential therapeutic properties (see Box 2.13), and hot spring resorts that directly use geothermal waters are popular facilities (see Box 2.12). According to a survey by the Global Wellness Institute, nearly 27,000 establishments across the world used thermal springs for bathing and other traditional practices in 2017 (Global Wellness Institute 2017). This sector is estimated at a \$56 billion worldwide market, with revenues varying by region (see Figure 2.7).

Geothermal resources can also be used to heat up water, via heat exchangers, for swimming pools and spas. This is sometimes necessary when the chemistry of the geothermal fluids is not suitable for bathing or not available in sufficient quantity to fulfill the water quality and safety requirements. Water in bathing facilities is usually treated above 32°C. Recreational swimming centers can be connected to a district heating system and contribute to the feasibility of the system with a load profile different from space heating. Such facilities will require a constant flow to heat up the pools and supply heat for showering, whereas buildings will have their load profile more connected to the weather conditions and daily variations. The Zakopane, Poland's district energy system, increased its revenues through the incorporation of a major spa and swimming pool facility that significantly balanced the heat load over the year.

In combined production, geothermal water from a geothermal power plant can be used in bathing and swimming facilities, as is the case in the Blue Lagoon (a geothermal resource park in Iceland) (see Box 2.13) or the KenGen Geothermal Spa connected to the Olkaria geothermal power plants.

**FIGURE 2.7: NUMBER OF THERMAL/MINERAL SPRINGS ESTABLISHMENTS AND REVENUES BY REGION**

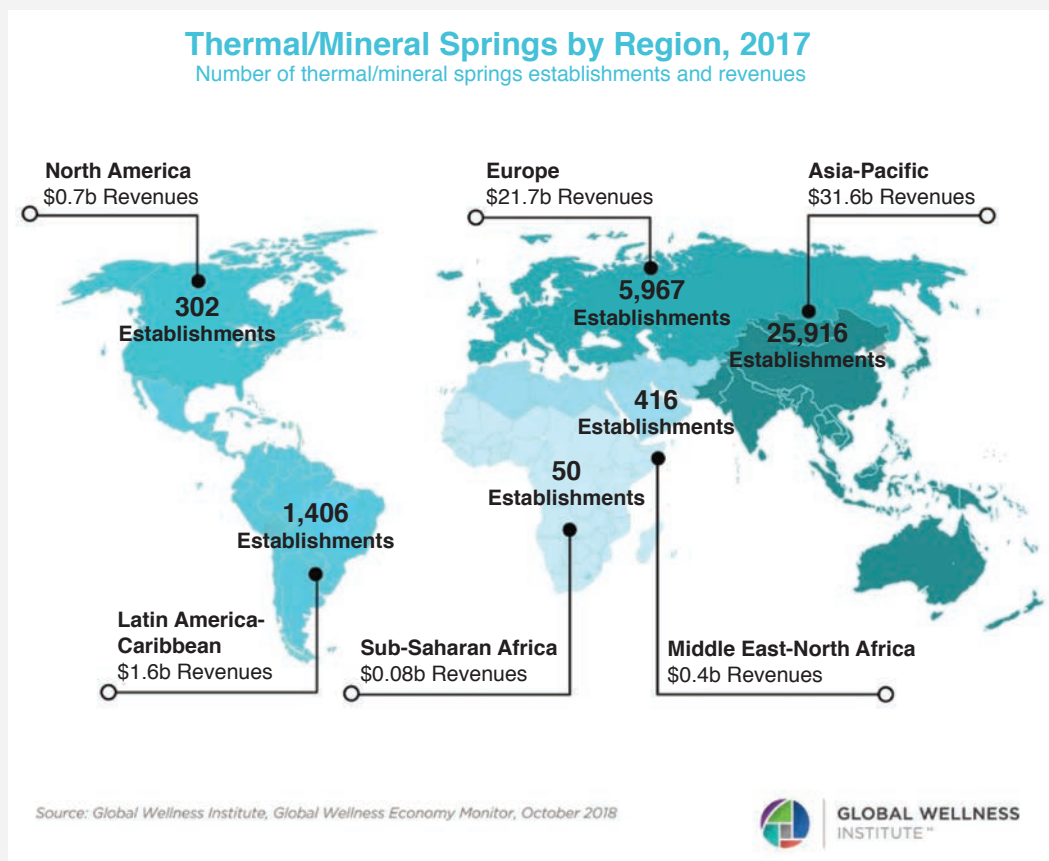

Source: Global Wellness Institute October 2018.

Note: Estab. = established; b = billion.

### BOX 2.12: TAKHINI HOT SPRINGS, YUKON, CANADA

The Takhini hot pools in Yukon, Canada, have been popular for centuries. A pool made of canvas and wood was developed in the beginning of the twentieth century.



The Takhini hot springs naturally flow at 6.3 kilograms per second at 47°C. The water contains various minerals, such as calcium, magnesium, sodium, silica, potassium, and iron. Its natural composition is thought to improve physical health and general well-being.

*Source:* Takhini hot pools n.d.

### BOX 2.13: BLUE LAGOON GEOTHERMAL SPA, ICELAND

The Blue Lagoon geothermal spa in Svartsengi, Iceland, has leveraged cogeneration to create a recreational phenomenon. Before its development, this part of Iceland was not a specific tourist location; however, it is now one of the most sought-after tourist experiences in Iceland, despite being nestled in the front yard of a power station. It should be noted that although today's facilities at the Blue Lagoon involved heavy investment, the origins of the success date back to installations that were simple—a few showers, dressing rooms in huts, and a rope to keep people from swimming into the hotter waters of the lagoon.



Photo credit: © Alamy, Creative Common license.

The Blue Lagoon has multiple products: the Blue Lagoon, Silica Hotel, retreat spa, retreat hotel, restaurants, and skincare products. In 2019, the Blue Lagoon employed 809 people, of whom 59 percent were women (compared to around 80 employees at the combined heat and power plant). In 2018, the Blue Lagoon received the Equal Pay Certification according to the equal pay standard IST 85. Applicants have equal access to available jobs at the company, which provides equal opportunities for all positions. Women are represented in all parts of the company structure, be it within the board, director group, middle management, specialists, technicians and specially trained employees, shift and project managers, in addition to other positions.

Blue Lagoon SkinCare products contain silica mud from the geothermal fluid received from the Svartsengi geothermal power plant for its bathing facilities. The company's first five products were introduced in 1995 following studies on the benefits of the fluids on psoriasis. Research and development of utilizing the silica rich geothermal fluid in various products has been strongly supported, and the company has worked with scientists within the fields of biotechnology, dermatology, and marine cosmetology.

Today, the Blue Lagoon has gained international fame and attracts more than 1 million visitors each year.

Sources: Blue Lagoon n.d.; [www.bluelagoon.is](http://www.bluelagoon.is).

# 3. THE ENABLING ENVIRONMENT: SETTING UP FOR SUCCESS

The establishment of an adequate enabling environment is as important to the development of GDU as the identification of the resource itself. The success of GDU is highly dependent on various local conditions, such as the characteristics of the geothermal resource, business opportunities to use it, and the price of alternative energy sources with which it will compete. Success also depends on support from public and private sectors, investors, and the local communities that are adjacent to geothermal facilities and that will benefit from them.

It is the responsibility of the government to ensure strong legal and regulatory framework to govern the permitting and, land access, and formulate industrial/rural development plans to encourage development of GDU. Few geothermal projects have materialized without incentives, risk mitigation, or private-public partnership. Further, countries differ in how advanced they are in utilizing geothermal. For countries with mature geothermal electrical generation, encouraging cogeneration should be a priority, as up-front risk of projects has been minimized; however, while independent projects should not be forgotten, a different mechanism might be needed as low- to medium-temperature resources are more widespread than high-temperature resources which is often used for electrical generation.

Governments should also plan to maximize social and economic benefits from GDU projects. This can be done on multiple levels, for example, by mapping the capacity in the country and where to focus the capacity building. Governments can make requirements to developers regarding local employment, gender equality, and inclusion of local communities.

As shown in Figure 3.1, the four key dimensions of an enabling environment for the development of GDU are (ESMAP 2012):

- **Geothermal knowledge:** availability of information on the resource, feasibility of applications, as well as skills and capacity among entrepreneurs and the workforce
- Supportive government **policies** supporting the development of such projects, including financial incentives and support mechanisms
- A **legal framework**, backed by adequately strong institutional structures, to support geothermal utilization development
- **Social acceptance** and **local consultation** that features the participation of stakeholders

This section provides an overview of each of these dimensions in advancing GDU.

**FIGURE 3.1: KEY COMPONENTS OF ENABLING ENVIRONMENT FOR GEOTHERMAL DIRECT UTILIZATION**

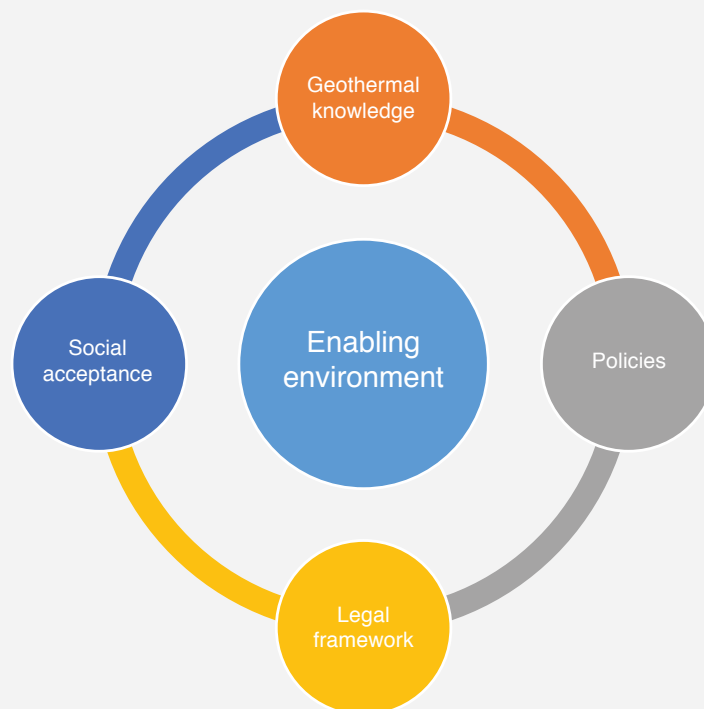

Source: Original figure for this publication.

## GEOTHERMAL KNOWLEDGE

### Mapping Geothermal Resources

Key to the development of geothermal utilization is information on a country's geothermal resources: geological data, locations, accessibility, volume, and composition of the geothermal fluids. Analysis of available data on direct-use potential in various countries around the world indicates that such data are incomplete or inaccurate—or altogether absent. Mapping the geothermal potential at the regional or country level is a fundamental first step toward implementation. Quality data on resources, coupled with information on potential markets for various applications, are critical to determine the feasibility of related projects. Studies that are built on reliable exploration data and market conditions help identify and prioritize projects.

It is the role of the country's government to oversee and organize geological surveys and geothermal mapping and ensure that such information becomes available for use by potential developers and researchers. The government, as regulator, institution, and policymakers collects data and ensures compliance with licenses, providing access to the public and private sector, and, most importantly, to ensure that the country's geothermal data is stored. The developer, whether private or public, have the responsibility to comply with the license and monitor, interpret and provide data to the regulator. This information can benefit multiple developers by reducing project risks during the initial development phases. At the same time, some of the information can be kept confidential in the short run to protect developers'



interest. Typical data gathered encompass geological, geophysical, and geochemical characteristics; estimated resource depth; information needed for drilling, such as temperature, pressure, and faults' permeability; and groundwater characteristics (as part of environmental monitoring). Skilled interpretation is critical, to gain insight into the utilization potential of the given resources. Figure 3.2 summarizes the various geothermal data that characterize a geothermal resource. It is best practice for regulators to store these geothermal data in a central databased for developers to acquire and share these data.

As an example, the Dutch policy on making geological databases available to the public is considered a contributing factor to the development of geothermal heat projects, including direct-use projects (IRENA 2019). Under the Dutch Mining Act, operators of mining, oil, and gas projects are required to make subsurface data available to the public after a certain period of time. The data are publicly accessible via databases such as the National Key Registry of the Subsurface (Basisregistratie Ondergrond) (Ministry of the Interior and Kingdom Relations n.d.) and the clearinghouse for data on the shallow and deep geology of the Netherlands, DINOloket (DINOloket n.d.). Availability of data has reduced operators' risk, a significant enabling factor for the development of GDU projects (IRENA 2019, 2020b).

### Resource Management

As with all geothermal projects, direct use of low- and medium-temperature geothermal resources must be conducted with care and foresight. Overexploitation over an extended period may require a long recovery period to restore the geological field; it may also have an irreversible impact on the resource.

**FIGURE 3.2: INFORMATION CHARACTERIZING GEOTHERMAL RESOURCES**

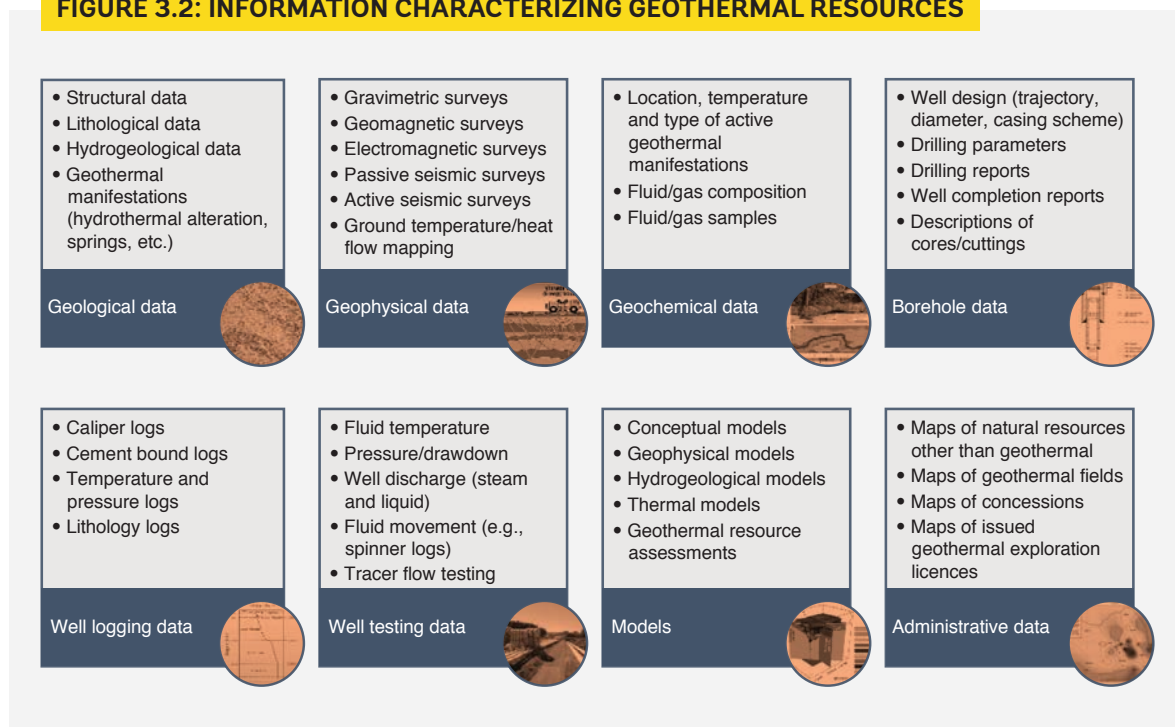

Source: Original compilation for this publication.

Consequently, a general concern is how to plan a resource's economical use. In other words, a project must extract and reinject water and heat at a rate that maximizes the economic value of the resource over its lifetime. The rate of extraction depends therefore not only on the physical characteristics of a resource but also on the social discount rate and the economic cost of alternative energy resources.

It is common for the water level in a geothermal reservoir to diminish when it is extracted over time. Reaching a sustainable exploitation level requires that this level be stabilized during the exploitation process, so it does not keep lowering, and that the system be able to return to the same initial level over time if system operations are slowed or halted. There are many examples of reaching an equilibrium after an initial phase of drawdown; this is considered normal and does not necessarily mean that the resources are exploited in an unsustainable manner. It is necessary to explore the resource to be able to size the project based on proven potential. Monitoring the resource is also a key aspect of its management over time, to be able to adjust its exploitation and avoid unsustainable utilization; and to understand if it is replenished through the underground system, or recycling of the fluid, or both.

Over time, reinjection might play an important part in the replenishment of the system. However, replenishing water is not the only issue, even if it is the most common. Temperatures may decline over time, indicating both a decrease in energy production and an unsustainable level of exploitation. While this does not necessarily mean that the exploitation of the resource should cease, it does indicate a need for adjusting the process.

Regular monitoring is therefore key to resource management. It is also recommended that operators be required to report to agencies responsible for geological surveys, or to other appropriate authorities that oversee the utilization of local and national geothermal resources.

## **SUPPORTIVE GOVERNMENTAL POLICIES**

Countries have various tools at hand to influence the undertaking of certain projects in their territory as part of their overall national goals and policies. Direct use of geothermal could contribute to various policy goals such as enhancing food security, fighting energy poverty, increasing energy independence, and mitigating the effects of climate change, thus bolstering society's resilience to climate change and contributing to decarbonization.

At the national level, the issues briefly presented here and in previous sections can be tackled with various policies and national plans. Renewable energy targets are an important aspect of the supportive policies that a government can undertake to help advance GDU projects. Several country governments have done this. The Netherlands has seen remarkable growth in geothermal heat projects in the agriculture sector (see Box 3.1), Mexico's 2018 Renewable Energy Technology Road Maps included a special section on the direct use of geothermal heat and, in 2020, the country's first industrial-grade geothermal food dehydrator started operations in Nayarit (see Box 2.7). Kenya considers GDU to be a key component of achieving energy and food security (Government of Kenya 2008) and, while Costa Rica acknowledges GDU's role in industrial development and decarbonization (Häehnlein, Bayer, and Blum 2010).

At the sector level, policies that distort the level playing field for energy technologies need to be reformed. In most countries, the price of fossil fuels does not reflect the economic cost of their use to society. As a result, renewables are underutilized. Further, many countries that have geothermal resources also have fossil fuel subsidies that lower the market prices of energy. For example, it is not uncommon for fossil fuels used for district heating to be priced well below market levels, thus discouraging the adoption of geothermal energy for that application.

### BOX 3.1: NATIONAL POLICIES ENCOURAGE GEOTHERMAL ENERGY IN THE NETHERLANDS

The impact of national policies on expanding the use of geothermal energy is clearly seen in the Netherlands (IRENA 2019, 2020b; Ministry of Economic Affairs and Climate Policy 2020; Ramsak 2020). Since 2007, the growth of geothermal heat projects has been remarkable, especially in the agriculture sector, where most of the projects are dedicated to heating commercial greenhouses. The combination of policies and support schemes used in the Netherlands includes:

- A geothermal action plan with target of 11 PJ of geothermal heat by 2020
- Public access, via online geological databases such as the Basisregistratie Ondergrond and DINOloket, to subsurface data, which mining, oil, and gas operators are legally required to make available
- A geothermal guarantee scheme covering geological risk
- A support scheme, the Stimulation of Sustainable Energy Production and Climate Transition, which provides an operating subsidy to sustainable energy production projects, including geothermal heat projects
- A plan to accelerate the development of geothermal resources for horticulture

This figure shows the dramatic growth of geothermal development in response to those policies.

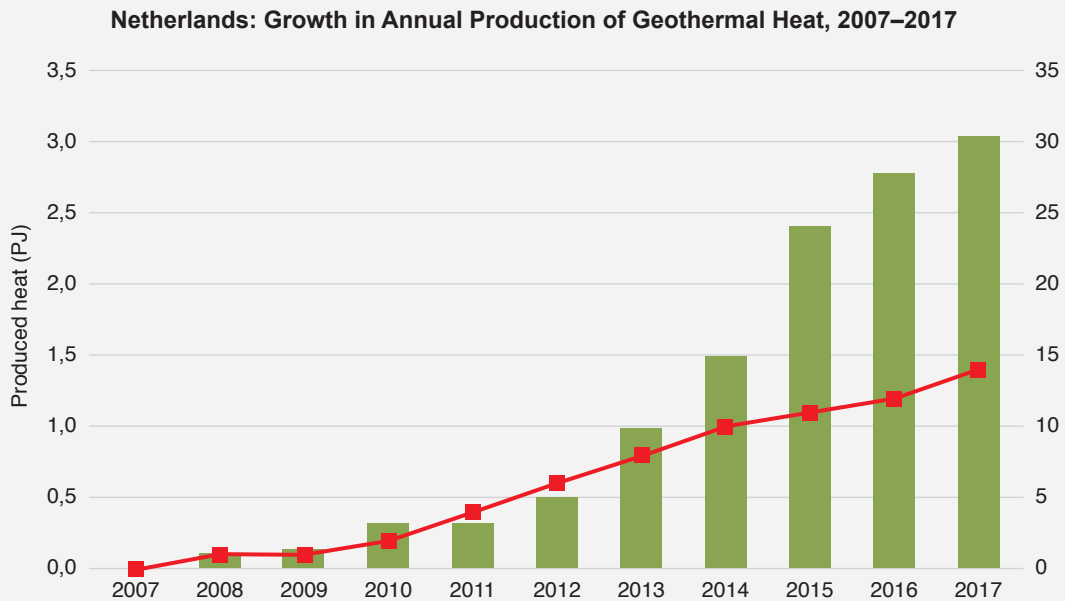

Source: Ministry of Economic Affairs and Climate Policy in the Netherlands 2018.

Note: PJ = petajoule.

(continues)

### **BOX 3.1: NATIONAL POLICIES ENCOURAGE GEOTHERMAL ENERGY IN THE NETHERLANDS (Continued)**

#### **The Stimulation of Sustainable Energy Production and Climate Transition**

In the Netherlands, the Stimulation of Sustainable Energy Production and Climate Transition scheme (SDE++) is available to support shallow, deep, and ultradeep geothermal heat projects. SDE++ is the follow-up of the Stimulation of Sustainable Energy Production scheme (SDE+). SDE++ offers a subsidy that compensates the difference between the cost of the sustainable energy (or the reduction in CO<sub>2</sub> emissions) and the revenue. The subsidy is calculated for a period of 12 to 15 years, depending on the energy resource. As part of the first rounds of tenders for SDE++ in fall 2020, relating to deep and ultradeep geothermal heat projects, the subsidy term was 15 years (Ministry of Economic Affairs and Climate Policy 2020). Furthermore, four geothermal heat projects, for a total capacity of 101 MW, were awarded a subsidy in a global amount of €245 million during the last round of SDE+ in spring 2020.

The Netherlands has also implemented a geothermal guarantee scheme to cover the geological risk of geothermal projects utilizing heat. As of March 2020, there had been nine rounds of guarantee allocation since 2009; 28 projects were submitted, and 11 realized, for a total amount of €146 million of cumulative guarantees.

At the local level, however, circumstances might foster conditions ideal for the development of niche activities based on geothermal resources for example in the geothermal resource park in Reykjanes (Box 4.6). It is important to facilitate and foster research and development in collaboration with local authorities via local planning and policy tools.

#### **Enabling Environment for Investments**

Geothermal projects differ from other renewable energy projects in that much of their relative risk is present at the early stages of project development. The upstream exploration phases, and especially the test drilling phase, can be considered the riskiest for projects that require drilling. Significant investment is required (if drilling is needed) before the feasibility of exploiting the geothermal resource for specific use(s) can be determined (ESMAP 2012).

Investment in GDU projects can come from both the private and public sector or in the form of a public-private partnership. Globally, the public sector has been a major developer of geothermal resources, mainly because governments can usually issue debt at lower interest rates than the private sector (allowing for a lower acceptable return on investment) and can take on more risk (because of the sheer size of a government's budget) compared to the private sector. Furthermore, governments often have policy goals for their investments other than simply maximizing returns. These goals can include diversifying the country's energy sector, reducing long-term greenhouse gas emissions, and stimulating the national economy through job creation. Several risk mitigation schemes have been tried throughout the years, and some have significantly contributed to the increased scale of geothermal (ESMAP 2016).

Risk sharing agreements between the public and private sectors during the exploration stages can significantly increase the chance of private investment in geothermal energy projects. For instance, Turkey has introduced a geothermal risk sharing mechanism available for both power production and direct-use applications (see Box 3.2), and Kenya has demonstrated a public-private partnership (see Box 2.4).

### BOX 3.2: RISK SHARING MECHANISM IN TURKEY

Implemented by the Development and Investment Bank of Turkey (TKYB), a **Risk Sharing Mechanism (RSM)** was created to increase private-sector investment in exploration drilling in Turkey by providing partial coverage of exploration drilling costs in case of unsuccessful wells. The RSM, which was capitalized with a \$38 million grant from the Clean Technology Fund, has been active since 2018. Under the first round, seven projects were selected for support, and three exploration drillings that benefited from the program. The second RSM round was launched in 2021 and, based on the evaluation of applications received, it is expected that up to 10 exploration drilling projects will be supported.

Under the RSM, an exploration drilling project is defined as the drilling of up to three wells (can be up to five in specific circumstances) in a given geothermal license area to validate the viability of power production, direct-use applications, or both. The exploration wells to be supported by the RSM can be of production size, medium size, or slim holes, as dictated by the drilling program necessary to meet the requirements of the supporting business plan.

Eligible license holders can apply to participate in the RSM. As the shows, 60 percent of the cost of failed wells will be covered in most of Turkey. However, only 40 percent will be covered within selected, already well-explored areas. The payout for a single drilling project will be capped at \$4 million. A success fee guarantee of 5 percent of the estimated well cost is provided by the beneficiary, either through a letter of credit or by establishing an escrow account.

When a completed well meets or exceeds the success criteria, which has been set on a custom basis for the drilling program, the success fee is retained by the RSM; otherwise, it is reimbursed to the beneficiary.

Standard RSM programs initially consider the drilling costs of three wells per project, although the program could be extended to a fourth and fifth well at a lower coverage (40 percent in all cases) and higher success fee (10 percent). What constitutes a successful versus an unsuccessful well will be based on an output threshold for each well that is contractually agreed between the RSM unit and the beneficiary pursuant to the needs of the beneficiary's business plan. Drilling success or failure criteria will be defined in gross output in megawatts, based on enthalpy (kilojoules per kilogram), flow (kilograms per second), well head pressure drawdown, and the temperature in the slim holes.

*(continues)*

### BOX 3.2: RISK SHARING MECHANISM IN TURKEY (Continued)

#### Geothermal Risk Sharing Mechanism

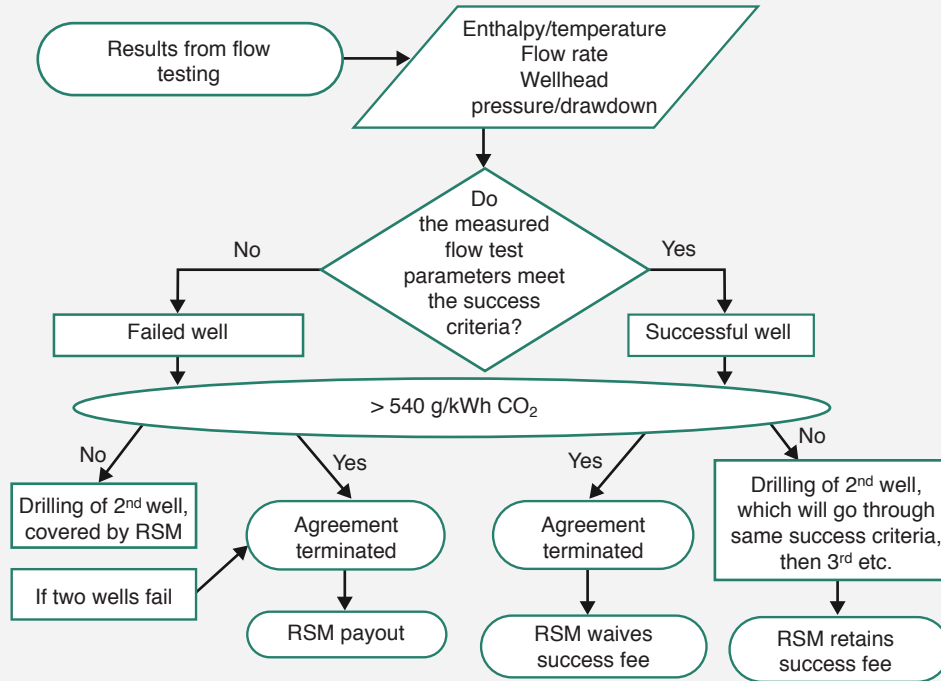

Source: TKYB and World Bank 2021.

Reliance solely on commercial capital for geothermal development is rarely a viable option, even in developed countries. Although direct capital subsidies are rarely used in those markets, government incentives such as loan guarantees and investment tax credits are often granted to geothermal developers. In developing countries, where the challenges involved in attracting private capital to geothermal projects are often greater, the commitment of the public sector—including the national government, international donors, and financial institutions—to contribute financial support is likely to be an essential element of success in mobilizing capital (ESMAP 2012).

Countries' commitment to expand or uphold their renewable energy targets can also have a positive influence. A country's renewable energy targets provide an important signal of whether to pursue geothermal energy investments. Developers prefer that government commitments include geothermal energy in their national plans and goals for obtaining electricity and energy from renewable energy sources (ESMAP 2018).

Factors, such as access to capital, can vary between countries and over time based on business-cycle fluctuations and economic and political stability. The legal framework relating to the protection of foreign and local investments also plays an important part in the decision to invest in a country. Investors pay particular attention to: (1) whether bilateral investment treaties exist between their country of incorporation and the country in which they invest; (2) whether the host country is a party to the World Bank's International Centre for Settlement of Investment Disputes Convention; (3) the capacity for the contracting authority to agree to international arbitration; (4) whether the host country is a party to the New York Convention on the Recognition and Enforcement of Foreign Arbitral Awards; (5) the validity of stabilization clauses; and (6) provisions on expropriation and indemnification.

## Financial Incentives and Support Mechanisms

The development of geothermal resources for productive uses has significantly depended on financial resources from the public sector. With a few exceptions, geothermal development in countries was kick-started with the aid of Governments, international financial institutions and other organizations that used public funds to provide financing at a lower cost than private markets. In theory, public financing for geothermal energy can be justified based on incomplete and imperfect markets. In the case of the geothermal sector, incomplete and imperfect markets broadly exist in the following forms: incomplete insurance and capital markets to hedge risks; imperfect competition due to barriers to entry, first mover advantages, potential economies of scale, incomplete and asymmetrical information; and spatial externalities resulting from the subterranean mobility of geothermal fluids.

More broadly, the state of energy markets beyond the geothermal sector can provide rationale of public financial support. Direct subsidies for fossil fuels amount to several hundred billion dollars each year while mechanisms to internalize the externalities from their use are hardly existent. These price signals lead to an over-consumption of fossil fuels vis-a-vis other fuels. It is often argued that in such a second-best world, public financial support for geothermal (and other renewables) would at least level the playing field, and at best improve the allocative inefficiency of current energy markets.

In many countries, electricity from renewable energy is the recipient of support mechanisms such as higher tariffs and risk mitigation funds aimed at promoting the development of renewable energy. Geothermal heat producers, however, do not often benefit from such schemes, with few exceptions such as the Netherlands (Box 3.1), France, and Iceland (Box 3.3).

## LEGAL FRAMEWORK

The importance of having a supportive legal framework to successfully implement GDU cannot be emphasized enough. In countries where relevant laws are unclear or nonexistent, developers simply lack basic confidence in the system or they feel the rules of the game are inadequate to support their

### BOX 3.3: INCENTIVE AND SUPPORT MECHANISMS IN FRANCE AND ICELAND

In France, users connected to a district heating system that is fed by renewable energy sources (at a proportion greater than 50 percent) have the value-added tax on their bill reduced from 20 percent to 5.5 percent. Tax exemption is seen as one way to promote renewable energy in the district energy sector and could be practical in countries where space heating and cooling are needed. Further, France created a Heat Fund (Fond Chaleur) in 2008 managed by ADEME (Agency for Environment and Energy Management), which has been subsidizing the installation of geothermal and other renewable systems based on technical criteria such as the energy efficiency of the system and the share of renewables in the overall energy mix of the system. ADEME is rethinking the existing guarantee mechanisms to incentivize investments by reducing project risk even more.

Another example of a successful incentive scheme, this time aimed at minimizing resource exploration risks, can be found in Iceland, where municipalities were granted low-interest loans covering up to 60 percent of drilling costs, which could be converted into grants if the development of a new geothermal field proved unsuccessful.

investment in geothermal, hampering the development of this sector. The main objective of a supportive legal framework is to ensure a transparent, cohesive, and reliable environment for the development of geothermal in general and direct use in particular (see Box 3.4). This is a prerequisite for securing long-term investments in the sector and the sustainability of the resource (European Commission n.d.).

While many countries have set up a clear legal framework for the utilization of high-temperature resources, less emphasis has been placed on the utilization of low- to medium-temperature resources. Some countries' legal frameworks are compatible with direct-utilization applications, whereas those of other countries are either unclear or do not really promote such utilization. For instance, current concession rights in Mexico allow a holder of a concession to exploit subproducts, except for hydrocarbons, and do not pose any limit to multiple or cascaded use of geothermal resources, provided that proper permitting is secured. This legal framework is thought to be a good example of how direct use can be promoted. Indonesia, however, has a more complex legal framework. A specific license has to be sought for direct utilization, making the process less attractive, especially for projects already producing electricity and where combined production could be feasible.

Many countries already have national legislation in place related to the exploitation of natural resources such as minerals, hydrocarbons, or water; in some cases, there are laws specifically governing geothermal resources. Direct use of geothermal can be integrated into existing frameworks, provided they do not limit potential applications. Similar to the production of electricity from geothermal, the key components of a

#### BOX 3.4: REGULATING DIRECT USES OF GEOTHERMAL IN MEXICO

After the publication of the 2014 Geothermal Energy Law (GEL), it was noticed that it did not adequately address the geothermal direct-use industry. With the support of the International Development Bank (IDB), a methodology was implemented to develop guidelines for direct uses of geothermal in Mexico. A stepwise approach was adopted to evaluate and identify gaps and to prepare the guidelines. This resulted in a proposal of guidelines published by the National Commission for Regulatory Improvement for evaluation.

Main characteristics of the guidelines proposed:

**Fast-track process:** A fast-track process was established to grant permits and concessions for direct uses both in terms of time and simplified requirements.

**Non-exclusive rights:** The concession grants temporary rights to harness and exploit the geothermal resources without granting real estate rights over the land. Unlike geothermal generation projects, geothermal permits and concessions for diverse uses do not confer exclusive rights to the developers. The rights to use or own real estate where the geothermal project will be physically located should be separately obtained by the developers.

For power-generation projects that want to take advantage of direct uses either themselves or through third parties, is permitted to do so but the utilization is the responsibility of the holder of the exploitation concession for power generation.

*Source:* IRENA and <https://cofemersimir.gob.mx/portales/resumen/46008>, <https://cofemersimir.gob.mx/mirs/46008>



supportive legal environment may vary significantly from one country to another. However, these components often encompass the following aspects:

- Definition of geothermal resources
- Resource ownership and protection
- Access to the resource
- Licensing system and permitting rules
- Institutional matters
- Access to networks or systems whereby multiple users and applications share resources
- Operation and decommissioning of plants
- Energy pricing structures
- Environmental regulations
- Applicable fees, taxes, and incentives

The main difference between electricity production and direct application of geothermal is that the latter is often realized at the site by local end users, instead of being distributed to the grid. The potential thermal use of a geothermal resource for district heating, for example, also has to be integrated in various legislation tools, such as building codes, local planning, and sustainable resource management.

### **Definition of Geothermal Resources**

Unlike electricity production, direct use of geothermal resources may imply both accessing heat and extracting certain minerals and gases, rendering the definition of geothermal resources less straightforward. In general, various parameters can be used to classify and define geothermal resources based on their potential energy and content: depth, flow rates, pressure, enthalpy, mineral and gas content, and geothermal or thermal waters.

Another aspect is the intended use of the exploitation related to the thermal content and mineral/gas extraction of the direct-use application(s). This is translated in terms of end use, installed capacity, and the order in which different applications can access the resource; these parameters might need to be used in the legal framework to further describe the geothermal potential and support the licensing process. Some countries have restricted the types of uses of the geothermal resources in the utilization licenses. In such cases, if the license holder envisages specific uses of the resource for example heat production, the work plan and the license must specify the uses for which the license is being issued. Usually, subproducts found in the geothermal resource may be harnessed, provided the corresponding authorization has been secured from the relevant authority. For instance, harnessing minerals contained in the geothermal fluid usually requires a mining license issued by the authorized party.

### **Resource Ownership and Protection**

The question of ownership and right of use of a geothermal resource is crucial in a direct-use project, especially one developed and operated by a private entity. For instance, is a geothermal reservoir or field a national

resource, or is it under the control of the landowner? Since a project relies on secured access and the right to use and dispose of geothermal heat, fluids, and other components of the geothermal resource, it is essential that developers have a clear view of their rights and responsibilities.

Ownership and right of use are all the more important in the context of the cascaded use of geothermal resources. In such a configuration, the resource (for instance, a geothermal industrial park) is utilized by a chain of users who need to secure their rights to the resource and to clearly understand the scope of such rights. An adequate and clear legal and contractual framework is key to the success in this instance.

As with any natural resource, ownership of, or the right to use, a geothermal resource must be clearly defined at the national level. Depending on the area, ownership may pertain to groundwater, thermal water, minerals, and other substances and resources. Determining ownership can be challenging in the absence of clear provisions.

In general, the legal framework should ensure that the ownership of a resource is vested in the state (national government), which then assigns licenses for its exploration, development, and exploitation. This should happen in a transparent and nondiscriminatory manner and for a sufficient duration, to enable developers and investors to secure a feasible rate of return on their investment.

The legal framework should also ensure the sustainable and rational management of the geothermal reservoir. However, stringent legislative or regulatory provisions might prove counterproductive and deter private developers from investing. Depending on the licensing authority's level of knowledge of the resource, the measures necessary for its conservation should be included in the exploration or utilization permit or be left to the discretion of the developer within certain limits. Furthermore, practices should adapt to changing circumstances and improved knowledge of the resource.

### Licensing System and Permitting Rules

Legislation concerning the utilization of geothermal resources should set priorities for its potential uses, such as for potable water, agriculture, renewable energy, sport and recreation, and therapeutic hot springs. This is best tackled in the licensing process and in the legislative framework to avoid overlap or conflicts between various uses.

A general good practice is to have a comprehensive and efficient licensing system for the geothermal resources managed by a governmental entity. Exclusive rights for exploration, development, and exploitation of geothermal resources should be guaranteed, not only according to an appropriate timescale but also on a geographical scale to ensure that there is no conflict of interest between parties potentially tapping into the same resource.

Careful attention should be paid to the time frame allocated for exploration licenses. Otherwise, resources suitable for development may be left dormant even though alternative developers are ready to act. Furthermore, a suitable framework needs to be established for the applicable licensing authority to cancel licenses, or restrict operations under a license, if the actions of the license holder are deemed to be detrimental to the sustainability of the resource or are otherwise unauthorized, unqualified, or unlawful.

When groundwater abstraction or exploitation is involved, permitting should be in line with national groundwater abstraction, exploitation, and pollution control permitting rules. When reinjection is not used, discharge control permitting should be in place to ensure minimum environmental impact.

The relevant licenses or permits should grant the holder adequate protection against third-party projects or activities that could damage the geothermal resource (such as mining, groundwater extraction, or quarrying projects in the same area). To ensure the preservation and the efficient use of geothermal resources, states may find it appropriate to give priority to geothermal projects over other exploitation of underground resources.

Monitoring should be among the licensing requirements to ensure sustainable resource use and reinforce the national geothermal utilization strategy by updating national plans with actual data.

Finally, the cost and complexity of the geothermal permitting process should be kept reasonable, in light of the expected economic return and the importance of promoting direct use of geothermal as part of national action plans.

### **Institutional Framework**

Another key enabling factor for all geothermal projects, including those involving direct use, is the simplification of procedures and institutional frameworks. Creating a “one-stop shop” administrative structure for the licensing authority responsible for interactions with project developers could be beneficial to the development of direct-use projects by streamlining the permitting procedure and providing official documents (and thus security) to project developers. As part of such a system, a single office would be in charge of, among other activities, receiving all applications and delivering permits. The office would be responsible for coordinating administrative processes with all other relevant institutions and would be developers’ only point of contact with government authorities. In Iceland for instance Orkustofnun (The National Energy Authority) promotes sustainable development and utilization of geothermal resources. When possible, the licensing office should also oversee monitoring the developer’s geothermal activities during the validation period of a permit.

When direct-use projects are developed at a regional rather than national level, regional authorities should be involved in the process. If relevant and consistent with the national administrative organization of the country in question, having a local authority as a one-stop shop might prove more efficient. Decentralization of regulation would indeed enable project developers and institutions to adapt to the particularities of the area where a project is being developed.

### **Environmental Regulations**

Protecting the environment as well as the health and safety interests of living beings from possible negative impacts is also a responsibility of national and local governments. Environmental regulations must tackle this by promoting environmental impact assessments when deemed necessary. The scope of these assessments is typically commensurate with the size and risk of the project, and some assessments include social impacts as well (Box 3.4). As a general rule, environmental regulations related to direct use are expected to mainly focus on land use, groundwater protection, soil protection, protocols for microseismicity (tremors), and other surface issues related to the exploration and exploitation of geothermal resources.

An unclear legal framework is considered a deterrent for potential investors in direct-use projects, as their utilization rights and rules of the game would not be clear in the mid and long term. In this respect two main categories have been identified as the most crucial: conflicting land use issues and supporting infrastructure.

**Conflicting land use issues.** Local planning and land use must be carefully considered for direct-utilization projects. Sometimes, geothermal resources are found in national parks or areas with great cultural and heritage value, which requires weighing the pros and cons of resource utilization.

In rural areas where agriculture is crucial to the local economy, no actions aiming at reallocation of land for geothermal agro-industrial or industrial uses should be taken before a careful weighing of their pros and cons. Such measures should furthermore be carefully integrated in the local economy to counterbalance any potential losses to the affected communities. Many low- to middle-income countries are highly dependent on agricultural activities, and a shift in land use may pose problems. But such a shift might be for the greater benefit of these communities, enabling an increased value for goods produced and reducing food waste, as intensive agriculture with geothermal greenhouses or food drying expands local food production capabilities. Local communities, with support from national legislation frameworks, typically have a role in deciding on land use. Such decisions rely on adequate information on actual resource potential and the stakes of utilization.

**Supporting infrastructure.** Also related to land use is the issue of infrastructure, which is often in the hands of the local government. Typical infrastructure related to GDU includes roads and pipelines. A district heating system may be spread across an entire city. The entity responsible for managing the infrastructure varies by country. In Turkey, as in many other countries, few municipalities have the financial capabilities to undertake the development of a geothermal district heating system and have therefore resorted to concessions to private companies to develop such projects. In Ukraine, Kazakhstan, and Mongolia, the district heating sector is traditionally publicly operated, however, there have been recent moves toward reforming the sector, such as by reviewing tariff policies and involving the participation of the private sector.

A clear national requirement is essential, but international standards such as the International Finance Corporation (IFC) performance standards (PS)<sup>3</sup> and the World Bank Environmental and Social Standards (WB ESF ESS)<sup>4</sup> provide best practices. All geothermal projects have associated environmental and social risks, and it is essential to manage these impacts and risks to ensure successful project development (Box 3.5). Depending on the maturity of a project, the scale and scope of environmental impact assessment (EIA) varies.

### Legal Aspects of Geothermal Industrial Parks

One way to look at the concept of geothermal industrial parks (GIPs) is to consider them as eco-industrial parks (EIPs, Boxes 3.6 and 3.7), which exclusively or partly integrate the use of geothermal energy.

GIPs combine various activities that use geothermal energy of greater or lesser heat levels. Usually, the core of the GIP is a plant that generates electrical power and possibly facilitates other uses with the residual heat, which will then provide other businesses in the park with power and heat, as well as minerals. Activities found in GIPs include power and heat generation for: balneology, greenhouses and food drying, fish farming, meat processing, cooling, and other innovative applications.

Connecting businesses in a GIP raises various legal and regulatory issues. Most of those issues are common to all multiuser geothermal projects (regardless of whether they are part of a GIP), but some are

<sup>3</sup> <http://www.ifc.org/performancestandards>

<sup>4</sup> <https://www.worldbank.org/en/projects-operations/environmental-and-social-framework/brief/environmental-and-social-standards>

### BOX 3.5: ENVIRONMENTAL AND SOCIAL IMPACT ASSESSMENT

The standard mechanism used globally to identify and manage environmental and social impacts and risks is the Environmental and Social Impact Assessment (ESIA). The developer sponsors the ESIA, which is generally carried out by an independent party with appropriate expertise. Most countries require only an Environmental Impact Assessment (EIA) to be prepared for infrastructure investments. The scope and breadth of the ESIA is wider and deeper than most national EIA requirements.

An ESIA also identifies the extent and complexity of potential social impacts and the socioeconomic characteristics of a project area. Beyond fulfilling the requirements of a national EIA, an ESIA include additional components that reflect the policy requirements of various international agencies: an Environmental and Social Management Plan (ESMP), specifically prepared for managing the risks and impacts of the project; a Stakeholder Engagement Plan (SEP); a grievance redressal mechanism; and a series of sub-management plans to manage site-specific risks, including but not limited to community health and safety, waste management, occupational health and safety, emergency preparedness and response, as well as water management.

If the ESIA is carried out to supplement or update a previous EIA or ESIA, it will include an Environmental and Social Action Plan that assesses the content and implementation of previous efforts taken to identify deficiencies and to plan actions to bring the process up to international standards. Finally, stand-alone land acquisition and resettlement documents and/or a development framework or plan for local indigenous communities may also be required.

*Source:* ESMAP 2021.

especially relevant to GIPs: (1) ownership of the resource; (2) access to land; (3) cascaded use management; and (4) contractual issues pertaining to the use and quality of fluids.

The question of **ownership** of the geothermal resource is crucial to setting up GIP projects, as it will dictate: (1) the involvement of the state or public parties (provincial government, municipalities, etc.) and private landowners when they are not directly involved in the project; and (2) the relationships between the businesses participating in the GIP, as each business needs to secure a right to access the resource, either through an ownership arrangement (when the local legal system allows it) or by securing a right of use of the resource. Such a right of use could be in the form of energy agreements or a lease contract.

### BOX 3.6: ECO-INDUSTRIAL PARKS

The United Nations Industrial Development Organization (UNIDO) has defined EIPs as earmarked areas for industrial use at suitable sites that ensure sustainability through the integration of social, economic, and environmental quality aspects in their siting, planning, operations, management, and decommissioning. The term “greenfield eco-industrial park” is used for completely new EIPs, and the term “brownfield” is employed when an existing industrial park is transformed into an EIP (UNIDO 2017).

Regarding **land access**, the landowner needs to be involved, either as the owner of the resource, in jurisdictions granting resource ownership to the landowner, or in order for the developer to obtain access to the land. If the landowner does not intend to harness the resource and is not willing to grant access, most jurisdictions provide for expropriation and some form of compensation. Furthermore, GIPs must comply with the local zoning and master plan, if there is one. It is highly recommended that planning issues be identified very early in the process. Planning issues might also differ depending on whether the GIP is a greenfield or a brownfield project.

**The cascaded use of geothermal resources** also raises some legal issues in terms of liability. Liabilities need to be clearly allocated to the participants in a GIP. For instance, the fact that the geothermal resource is shared raises the question as to whether and to what extent participating businesses share the liability relating to resource management. Those questions need to be addressed in the local regulation or in the contracts between GIP participants and, when appropriate, the public authority.

Participants in the GIP are legally connected to each other by **contracts** such as power purchase agreements, heat supply agreements, steam supply agreements, public-private partnerships, and concession agreements. Those contracts address the following issues:

- Risk allocation relating to the quality of the fluid, damage to the environment, damage to third parties, force majeure, resource risk, and other relevant issues
- Security of supply
- Pricing, indexation, and taxes
- Financing of necessary infrastructure (district heating system, fluid pipeline, etc.)

## **SOCIAL ACCEPTANCE AND LOCAL CONSULTATION**

Communities near geothermal areas may be affected by various aspects related to the development and operation of a project. Geothermal features that are sometimes located close to protected ecosystems are often unique and can have spiritual and cultural meanings. Therefore, the use of local resources should always be governed in cooperation with local communities.

Further various governance solutions must be explored to find the most acceptable way to deploy projects for the benefit of all stakeholders involved. The adoption of best practices and industry standards is a key to social acceptance. Utilizing participatory approaches is seen as a good practice to build local community trust and maximize the benefits of a project for all players. Stakeholder engagement needs to be tailored to everyone's needs to ensure unrestrained participation of community members. For instance, women or indigenous peoples may participate in discussions differently than other community members.

Tailored engagement can be critical in avoiding potential conflicts, such as when a GDU project is implemented in an agricultural area that may disrupt traditional land use and replace existing jobs. Promoting direct use at the local level implies the integration of geothermal plans into industrial and rural development strategies in ways that demonstrate the benefits and applications. In recent years, geothermal power plants have in some countries experienced opposition from local communities; implementing a GDU project as a cascaded use at an early stage of development could be used to demonstrate to the local community the benefits of the geothermal resource. This requires extensive involvement between local communities and entrepreneurs to ensure the adoption of appropriate measures for the development of activities within a geothermal area (Box 3.7).

### BOX 3.7: COMMUNITY ENGAGEMENT IN ITALY AND NEW ZEALAND

An interesting governance model implemented in Tuscany, Italy, involved a consortium of local municipalities dedicated to promoting initiatives involving all the local economic and social actors around geothermal sites (IRENA 2019). The agreement, “General Agreement on Geothermal Energy,” envisages revenue redistribution to benefit the local community, to make investing in the environment more attractive, and to improve environmental impacts. Under the EU program GEOENVI, in 2021 113 MW<sub>th</sub> in district heating in seven municipalities are in operation and three more district heating systems are under preparation as well as brewery, dairy, and greenhouse agro-industries. Swimming pools and geothermal cooled data centers are also under construction (GEOENVI 2021). Such an example demonstrates that it is possible to bring together local players around the development of a geothermal area to attract investors and tourism while improving the impact of a project.

Another example is the inclusion of indigenous Maori peoples in geothermal projects in New Zealand. The Maori peoples are considered custodians of the land and its resources, and they collectively manage it through various models ranging from full participation to systems involving royalties from developers.

*Source:* GeoEnvi, <https://www.geoenvi.eu/wp-content/uploads/2021/02/geoenvi-wp4-local-benefits-in-italy-torsello-20210316.pdf>, and Miraka, <https://www.miraka.co.nz/>.

### Changes to the Environment and Health

As with all projects involving the utilization of natural resources, the direct use of geothermal energy has implications for the environment and, often, for the health of individuals. Environmental impact risks are mainly those related to water and air pollution at the drilling, construction, and operation stages of the project. Such pollution can negatively affect the health of the local population. Depending on the area, women may have less access to health care than men and thus may be likely to suffer the ill effects of health hazards. Furthermore, there is a risk of natural habitat damage in the environment adjacent to the project during all project life cycles, and the risk of hazardous waste disposal.

An additional risk to women’s health is posed by the influx of nonlocal workers, generally males during construction stage (ESMAP, 2019). This influx increases gender-based violence against the local female population, as well as engenders sex trafficking and the spread of sexually transmitted diseases and increased drug use. It is therefore important for all developers in a given country to have strong sexual harassment regulations in place.

### Education, Research, and Capacity Building

Many countries that have geothermal energy, lack the basic industry knowledge and experience, posing a barrier to innovative thinking about how to effectively and sustainably utilize the resource. This challenge can be addressed at the national level by putting in place educational strategies. Curricula should be designed to engage students in geothermal energy, for instance, through special geothermal courses; the involvement of geothermal professionals as role models, trainers, and mentors; and the promotion of geothermal career paths. Building the capacity of policymakers is also important as they need to see direct use as a contributor to socioeconomic development.

The UNESCO Geothermal Training Programme is a good example of how capacity building can be implemented. This postgraduate training program helps developing and transitional countries that have geothermal potential build capacity in geothermal exploration and development. The program has had a cooperative arrangement with the government of Iceland since 1978. More recently, the Africa Geothermal Center of Excellence was founded to build and strengthen African countries' institutional and infrastructural capacities, creating a critical mass of geothermal scientists and engineers on the continent.

Bringing new industrial activities to any given area commonly results in the creation of new jobs and trades, which may require suitable training and education programs if the local workforce lacks the requisite knowledge and experience. While many of these new jobs will not require skills with high levels of geothermal knowledge, educational strategies must be devised in concert with the various players to make sure direct-use applications can be smoothly implemented. Also, there will need to be a strategy that ensures that the local population takes up some of these new employment opportunities and fully participates in the operation of the geothermal applications as they develop.

Increasing the employment level of women in geothermal and especially in STEM-related (science, technology, engineering, and mathematics) careers is important for the development of the sector. This will expand the pool of talent and strengthening the sector while generating income and enabling women to contribute to an important sector for generations to come (Schomer and Hammond 2020). Here again it is important to remove any obstacle to women's access to jobs related to geothermal, not only at the policy level, such as with quotas and targets, but also at the corporate level—both during the recruitment process and by designing a work environment that addresses challenges such as sexual harassment, work-life balance, unequal wages, and opportunities for promotion.

Furthermore, while the ever-increasing automation involved in most industrial processes has and will continue to reduce the need for unskilled or trade labor, there will also be an increased demand for those educated in the fields of computer sciences, engineering, and technology. With respect to gender issues and equality, it is therefore important to set goals and strategic plans to increase women's interest in such career paths as well as boost enrollment in relevant fields of education.

### Gender-Equality Considerations

The GDU methods discussed in this report all require land for wells (if stand-alone), access roads, pipelines, and various buildings that house the equipment involved in each project phase. Land is also required for the applications themselves, to a varying degree depending on their nature.

Furthermore, acquiring land for the operation of a direct-use application requires, in most instances, the purchase or rental of land and a permit for land use. This may prove a hindrance for women entrepreneurs, who are known to have less access to funds when establishing businesses or operating them<sup>5</sup>.

ESMAP (2019) recommends tackling gender gaps from the onset of a project. In line with this, the potential impact on gender equality should be assessed for each region, as well as for each category or type of direct utilization. Assessments should consider the specifics of the region and the suggested utilization projects applicable to each. As the recommendations set forth put forward are not detailed, it is crucial that more detailed assessments be made for each region, project, or country in any future developments regarding direct use in these areas. This crucial if the goal is to decrease gender disparity. Examples of gaps, opportunities, and targets are presented in Figure 3.3.

<sup>5</sup> <https://www.unwomen.org/en/news/in-focus/financing-for-gender-equality>



**FIGURE 3.3: EXAMPLES OF GEOTHERMAL DIRECT USE AND GENDER EQUALITY: GAPS, OPPORTUNITIES, AND TARGETS**

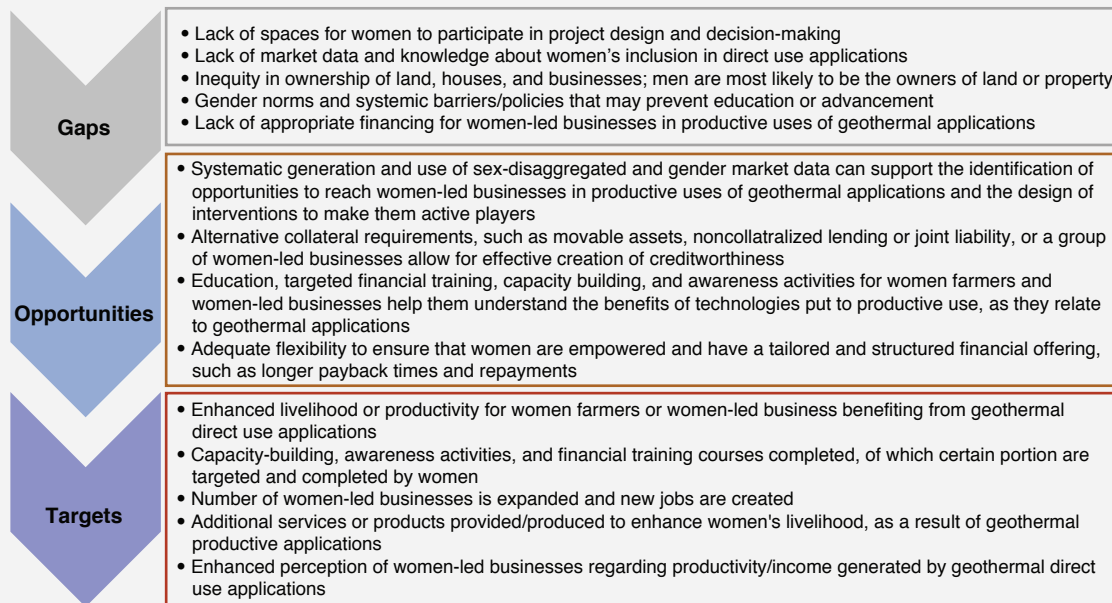

Source: Original compilation for this publication.

The data required for a proper assessment would include the employment rate of women in the local area, as well as women’s education level in various fields; access to loans; social constraints; gender-related legal frameworks; family structure; availability of childcare; income; transport access; health and nutritional status; fertility control; and political involvement. The data collected are likely to be both quantitative and qualitative. Depending on the region in question, the availability of preexisting data will differ. To monitor the impact of direct use, the indicators chosen should increase industry awareness of successful attempts at reducing gender disparity. As the gender discussion in this report is general in nature, context-specific analysis should be conducted where gender disparity is prevalent and direct use projects are foreseen.

Direct utilization can affect previous, traditional uses of a resource, as in the case of hot springs that lighten the burden of household chores—including laundry, washing, and bathing children—commonly conducted by women. A geothermal project may close off access to this basic use of the resource, thereby negatively affecting women who must then spend more time and effort on their chores. Furthermore, having to travel further to access resources can increase the chances of women being subject to gender-based violence. Loss of land can disrupt the agricultural activities of women and farm animal grazing. Utilization can also negatively affect small-scale tourism if the site considered for a project is one of natural beauty. Depending on the area, this may have a negative impact on female employment if tourism is hindered (e.g., tourist trinkets are often made by local women) (ESMAP 2019).

Despite these issues, direct use is more likely to increase gender equality than not if decision-making processes incorporate genuine community input and foresight early on. Government policies may need to review land rights and require legal reforms that correct the present social norms of land acquisition and

inheritance. This is possible, as shown by the 2019 Côte d'Ivoire Marriage Reforms which grants women equal rights to marital property (Arekapudinayda and Almodóvar-Reteguis 2020). Although legal reforms that oppose social norms tend to be a long-term goal, the benefits are enormous, as they provide women with assets, such as land, that enable them to establish businesses, which ultimately benefits their societies. Not only do women themselves reap the benefits of a better life and more opportunities, but so do their offspring.

Some examples of a direct-use project that has positively influenced women's opportunities are the Oserian Flower Farm in Kenya's Rift Valley (Box 2.4) and Blue Lagoon (Box 2.12).

Access to funds for land acquisition for female-owned or female-operated businesses can be provided through either international or national institutions as well as through loan-guarantee initiatives. According to the Women's Entrepreneurship Day Organization, women have a 97 percent repayment rate for microloans, making them ideal candidates for starting small businesses (WED n.d.). Although microloans may not provide enough funding to acquire land rights, there is no reason to doubt that the repayment rate would differ considerably if the loans were more substantial.

In the case of restoring the traditional use of a resource, a direct-use project can be made beneficial by, for instance, adding the requirement of pipeline access to hot water. Furthermore, a tap-off spot for cold water can be added when laying the water supply required for drilling. This would eradicate the need to travel farther for hot- or cold-water access. Regarding small-scale tourism, direct-use applications in areas of natural beauty should be developed in ways that enhance local attractions. By doing so, tourism and associated quality employment opportunities should increase, not decrease.

Examples of gaps, opportunities, and targets needed to successfully impact gender equality in direct-use project development are summarized in Figure 3.3. They include the need to address the lack of sex-disaggregated data in the specific field of GDU applications; conduct a gender-gap assessment analysis; identify and design tangible actions to address these gaps; and set targets or indicators that can be monitored and reflect the gaps' reduction. Furthermore, projects should actively consider men's roles as agents of change to improve outcomes conducive to gender equality.

# 4. PROJECT DEVELOPMENT: DESIGNING AND PREPARING GEOHERMAL PROJECT

Basic factors that influence the technical design of geothermal applications include the temperature and available flow rates, which determine the energy potential of a given resource. For a given flow, the thermal energy extraction is proportional to the water temperature drop that can be achieved by the application. Table 4.1 presents the flow and temperature drops required to extract 1 MW<sub>th</sub> from a geothermal fluid; essentially, warmer fluids require less volume.

**TABLE 4.1: GEOTHERMAL FLUID REQUIRED TO GIVE AN EQUIVALENT OF 1 MW<sub>TH</sub> FOR VARIOUS TEMPERATURE DROPS**

TEMPERATURE DROPS (°C)	FLOW (KG/S)
40	6
30	8
20	12

*Source:* Original compilation for this publication.

*Note:* kg/s = kilograms per second.

When considering the direct use of geothermal energy in any kind of process, the temperature of the source is important, or the temperature difference of the geothermal source and the process. The temperature difference controls the feasibility, flow requirements, and design of the direct-use equipment. There are two fundamental issues: (i) the difference between the geothermal temperature entering the system and the process temperature, which must be sufficient to allow feasible construction of a heat exchange unit; and (ii) the temperature difference between the geothermal heat entering the system and leaving the system. This determines the flow of geothermal fluid required to run the system.

As a rule of thumb, it is preferred that the source temperature be 20 to 25°C higher than the processing temperature. As an example, drying grain at 40°C would require a 60 to 65°C geothermal liquid, and pasteurizing milk or juice at 72°C would require a source of around 90 to 100°C. Innovative techniques allow a lower temperature gradient (see Van Nguyen et al. 2015).

Geothermal fluids are commonly richer in minerals than cold groundwater. The chemistry of the fluid might affect the feasibility of a geothermal application, as specialized system components and materials may be required for the application, and some countermeasures may be needed to handle scaling and erosion issues. The equipment selection is generally affected by components in the fluid, such as silica, oxygen, chlorides, calcium, magnesium, hydrogen sulfide, as well as the pH and temperature of the fluid. Some materials that could be selected for the equipment are carbon steel, stainless steel, fiberglass, or even titanium, depending on the fluid and the application under consideration. Furthermore, the fluid chemistry may change over time, due to the possible inflow of cold groundwater or seawater into the geothermal system. In low-temperature fields, scaling is not expected to be a major problem. The chemistry of the fluid will also determine whether mineral extraction is possible.

## SYSTEM DESIGN

Geothermal fields vary greatly from one place to another, depending on the temperature, depth of the resource, abundance of fluid, and characteristics of the geochemical features. Four approaches related to direct utilization of low- and medium-temperature resources are introduced below, from the simplest to the most elaborate:

- Self-flowing, artesian, geothermal resources, such as hot springs
- Self-flowing drilled wells
- Drilled production wells with well pumps to enhance
- Drilled production wells with well pumps plus reinjection of geothermal water to the reservoir via drilled reinjection wells

The following approaches, combined with geothermal power plant (GPP) electricity production, are a variant of direct use of geothermal and included in this study:

- Combined production (cogeneration)
- Cascaded use and integrated use

As a general good practice, reinjection should always be considered at the planning stage as part of the sustainable management of resources. In many cases, it plays an important part in restoring the geothermal field over time.

The following sections propose a description of these technical approaches that can be applied to various situations for the direct use of geothermal.

### Self-Flowing (Artesian) Geothermal Resources

Geothermal resources that are self-flowing at the surface, referred to as artesian, have been used since ancient times, especially for bathing, but also for space heating and farming. Typically, geothermal water is collected and piped to the place where it is used, as illustrated in Figure 4.1.

Figure 4.1 shows a heat conversion unit (HCU), which transfers the heat to the user's closed heating system or for other direct-use purposes. Where the chemical composition of the geothermal water is appropriate, it can be used directly, without the HCU. Self-flowing systems are usually rather simple and affordable to implement because they do not require drilling and have lower capital cost; fluid goes directly to the equipment needed to collect geothermal fluid above ground and distribute it. The use of artesian hot springs remains, however, small in scale due to limitations in the flow available and temperature of such geothermal features, generally in the range of 40 to 100°C.

Sustainability and environmental impacts require careful consideration when implementing projects. In the case of self-flowing geothermal resources, the question of withdrawing geothermal fluid that would otherwise naturally flow into a given ecosystem should be evaluated with regard to its environmental impact on the surroundings. In general, the utilization of hot springs for various applications will always be sustainable, as natural outflow will only be diverted (see Boxes 4.1, 4.2, and 4.3).

**FIGURE 4.1: DIRECT USE FROM SELF-FLOWING ARTESIAN GEOTHERMAL RESOURCES**

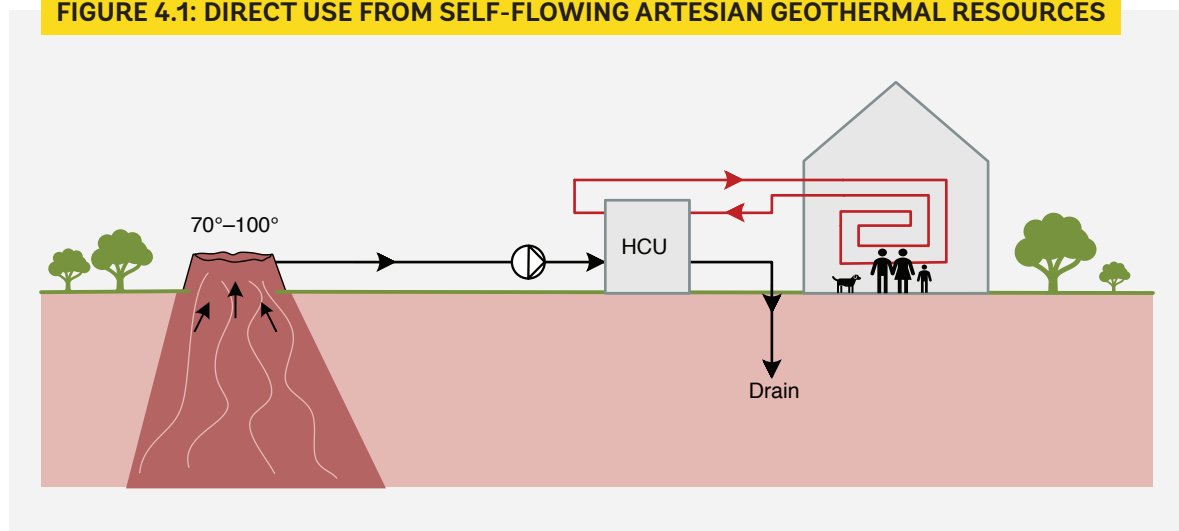

*Source:* Original figure for this publication.

*Note:* HCU = heat conversion unit.

#### BOX 4.1: ARTESIAN WELL: A GREENHOUSE HEATING SYSTEM, FLÚÐIR, ICELAND

Vaðmálhver is a hot spring located in south Iceland. It has been used since 1891 to supply water to a nearby pond, Gamla laugin, and was one of the first hot springs used to provide hot water directly for hot “tubs” in Iceland. It has been recently developed into the so-called Secret Lagoon and is now a tourist attraction, creating economic activity for the small community of Flúðir.

Some greenhouses nearby also benefit from the hot water from this spring, which is 100°C and flows at 9.5 kilograms per second. The photo shows the spring and pipe to the left, collecting hot water to direct it to the places where it is used. The natural previous outflow is located to the right.



Source: Secret Lagoon n.d.

#### Self-Flowing Drilled Wells

When geothermal resources do not flow naturally to the surface at a rate that is sufficient for the planned exploitation, drilling is required to enhance the flow of the geothermal fluid. The depth of a well can range from a few hundred meters to a few kilometers, depending on the location of the targeted resource. Drilling usually enables access to a greater flow and in some cases to higher temperatures, but drilling adds to project costs. However, the technical solution for harnessing the fluid is similar to the case of self-flowing wells, as illustrated in Figure 4.2.

#### BOX 4.2: ARTESIAN WELL: HOT WATER BEACH IN MERCURY, NEW ZEALAND

There are two fissures at the Mercury hot water beach issuing water as hot as 64°C at a rate as high as 0.25 kilograms per second. This water contains large amounts of mineral salts, calcium, magnesium, potassium, fluorine, bromine, and silica. The beach is popular with both locals and tourists for bathing, swimming, as well as relaxing and soaking in thermal water in holes dug at the beach.



Photo credit: © Getty Images.

The utilization of drilled artesian wells is always sustainable because the flow rate, though increased by drilling, is still determined by natural processes. It may be higher during the initial phase of exploitation but usually levels out over time to reach stable production conditions, as the natural recharge to the reservoir is in equilibrium with the exploitation.

#### Pumped Production Wells

If wells are not self-flowing as described in the previous subsections, they can be equipped with pumps to reach the desired production rate, as shown in Figure 4.3. The sustainable production level increases compared to the self-flowing well, provided that the water level in the reservoir is kept constant on average over time (allowing for seasonal variations). The utilization is usually expected to have an environmental impact on the surroundings if hot springs in the area were active prior to drilling and pumping, as the production wells affect the normal flow to the natural springs. The sustainable use of geothermal resources should not, however, be confused with the mitigation of environmental impacts. Many low-temperature geothermal areas in Reykjavík and other areas of Iceland have been exploited for decades, indicating that a certain equilibrium was reached in the use pattern despite the fact that the surface features were modified.

### BOX 4.3: ARTESIAN WELL: MULTIPLE USES IN DEILDARTUNGUHVER, ICELAND

Water from Deildartunguhver has been utilized for central heating since 1925. The Deildartunguhver spring is one of the most productive in Iceland. About 385 kilograms per second flows at approximately 97°C from various springs related to the geothermal resource in the area. Deildartunguhver itself delivers approximately 150 kilograms per second of which 75 percent is utilized today for geothermal district heating; the remaining hot water is also directly used in the neighborhood for greenhouses. For district heating, the water is collected at the spring and distributed some 60 kilometers away for use by two small towns, Akranes and Borgarfjörður (with about 10,000 habitants combined).



Source: Guðmundsson 2016.

### FIGURE 4.2: SELF-FLOWING DRILLED WELL

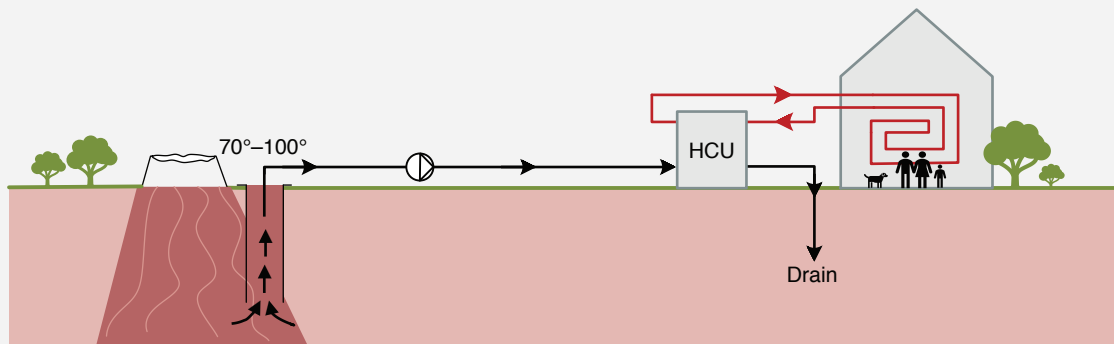

Source: Original figure for this publication.

Note: HCU = heat conversion unit.



**FIGURE 4.3: PUMPED PRODUCTION WELL WITHOUT REINJECTION**

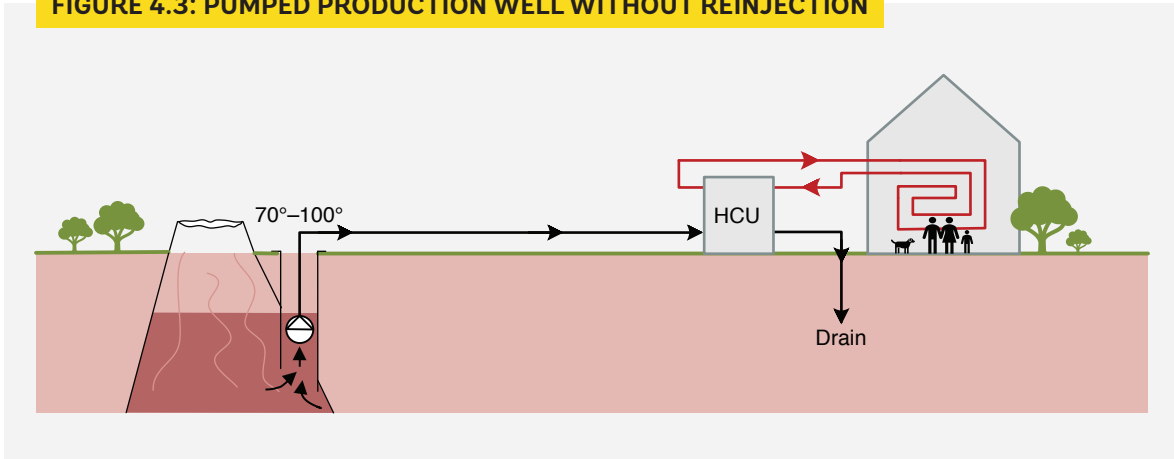

*Source:* Original figure for this publication.

*Note:* HCU = heat conversion unit.

Apart from what the resource itself offers, the size of the wells, the depth of the water level, and the type of pumps used will all have an impact on the well output, as further described in this section.

### Pumped Production Wells and Reinjection Wells

Planned exploitation of a geothermal resource must consider the impact of long-term extraction to avoid unsustainable extraction rates that may cause a continuous drawdown of the reservoir. Reinjection is usually necessary to comply with environmental restrictions on surface disposal, replenish the geothermal reservoir and contribute to its sustainable exploitation. However, this is not always necessary and is highly dependent on the resource conditions. One of the purposes of reinjection is to maintain a given equilibrium between the extraction and recharge of the resource.

Many direct use schemes are based on the installation of a geothermal doublet, a system that creates a closed loop in which the geothermal fluid is circulated. In most cases, all the geothermal fluid extracted is reinjected into the reservoir or into its vicinity to maintain the water level in the reservoir. Such systems usually require the drilling of one reinjection well for each production well (called geothermal doublet), depending on the characteristics of the geothermal resource. Geothermal doublets can be implemented, as shown in Figure 4.4.

Geothermal doublets are usually equipped with pumps and a heat exchanger to extract the energy from the geothermal fluid, creating the geothermal doublet loop (see Box 4.4). Another loop is the distribution system on the user's side, which enables distribution of the heat energy extracted at an appropriate level to the end-user application.

It is quite common to have the production and reinjection wells on the same well pad. However, their design should be such that enough spacing is ensured between reinjection and extraction points in the reservoir to avoid overcooling the production side, should the circulation be too rapid for appropriate regeneration of the temperature of the reinjected fluid.

**FIGURE 4.4: DIRECT USE FROM GEOTHERMAL DOUBLET**

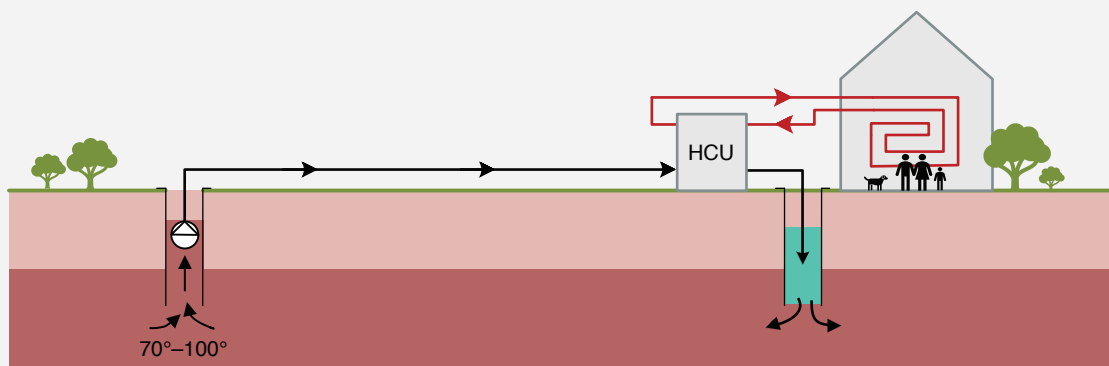

Source: Original figure for this publication.

Note: HCU = heat conversion unit.

### Combined Production

The geothermal industry has been developing for over a century. Geothermal utilization has evolved into schemes combining various types of direct use and electricity production. While high-temperature resources can be harnessed solely for direct applications, their preferred use has been for electricity production to supplement the nationwide grid.

Downstream use of the unutilized thermal energy, including extraction of chemical by-products such as minerals and gases, can provide new sources of revenue for the GPP owners. This may also mitigate the owner's risk by developing the various revenue streams, business opportunities, and enhancing public acceptance by helping contribute to a dynamic local economy around the geothermal area.

There are many ways to produce heat in parallel or in series with electricity production from a medium- to high-temperature geothermal field. Combined production is the production of heat in a cogeneration or coproduction scheme. In some cases, production of heat and electricity occurs in a scheme where heat is produced in cascade on the downstream end of the power plant. In other cases, heat is produced on the primary circuit, on the geothermal loop side. The setup will be highly dependent on the resource characteristics and the electrical process cycle selected.

### BOX 4.4: GEOTHERMAL DOUBLET: DISTRICT HEATING IN PARIS, FRANCE

The Dogger aquifer in Paris, France, has been utilized for 40 years, providing space heating for 5,000 houses. Deep geothermal operations (1500 - 2000 m deep wells) for heat production are in most cases equipped with geothermal doublets (one reinjection well for every production well), employed to fully reinject the geothermal water. This reduces the need for geothermal water surface disposal and supports the reservoir pressure.

Heat generated in the primary circuit, the geothermal loop (see HCU-P in Figure 4.5), generally results in higher temperatures than when generated on the cold-end side, which could also affect the performance of the power plant. Regarding the production of heat on the primary circuit, it can be done with either the geothermal water recovered from the separators in single-flash GPPs or on the return leg of the vaporizer in binary GPPs. If cooling is with a direct spray condenser, harnessing heat from the cooling circuit is usually not feasible. Typically, the temperature produced on the primary circuit is higher than 80°C, as shown in Figures 4.5 and 4.6.

Dry-steam power plants present a limited possibility to produce heat, mainly on the cold end, since the fluid is pure steam. Such power plants have great potential for the production of electricity but are less adaptable to a combined production mode. The heat extracted in these cases is also much lower, below 40°C, than in cases where heat is extracted on the primary side, and is more difficult to exploit.

As mentioned earlier, the production of heat in a combined mode depends on the characteristics of the geothermal fluid, its enthalpy, the process cycle, and the type of cold end selected for the production of electricity. Figures 4.7 and 4.8 show the amount of heat that can potentially be recovered or extracted in the combined production mode as a function of (1) the enthalpy of the geothermal fluid for a single flash turbine (Figure 4.7), and (2) the temperature for a binary power plant (Figure 4.8). In all cases, the reinjection temperature after direct use is assumed to be 40°C.

**FIGURE 4.5: COMBINED PRODUCTION: BINARY GPP WITH AIR-COOLED CONDENSER FOR WASTE HEAT FROM THE COOLING AIR STREAM**

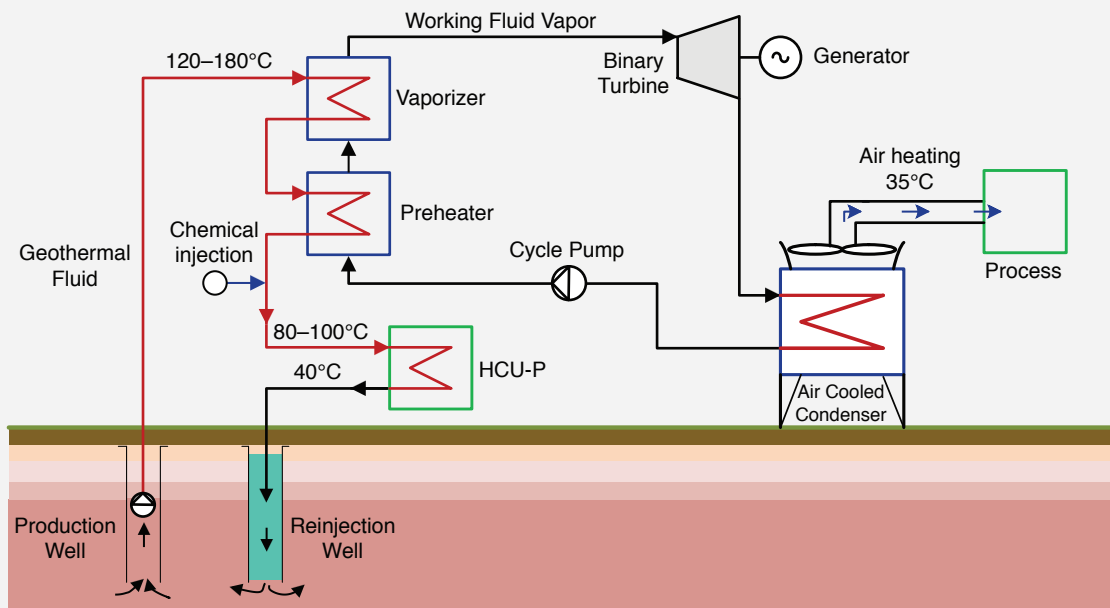

Source: Original figure for this publication.

Note: HCU-P = heat conversion unit, primary side.

**FIGURE 4.6: COMBINED PRODUCTION: SINGLE-FLASH GPP WITH SPRAY CONDENSER**

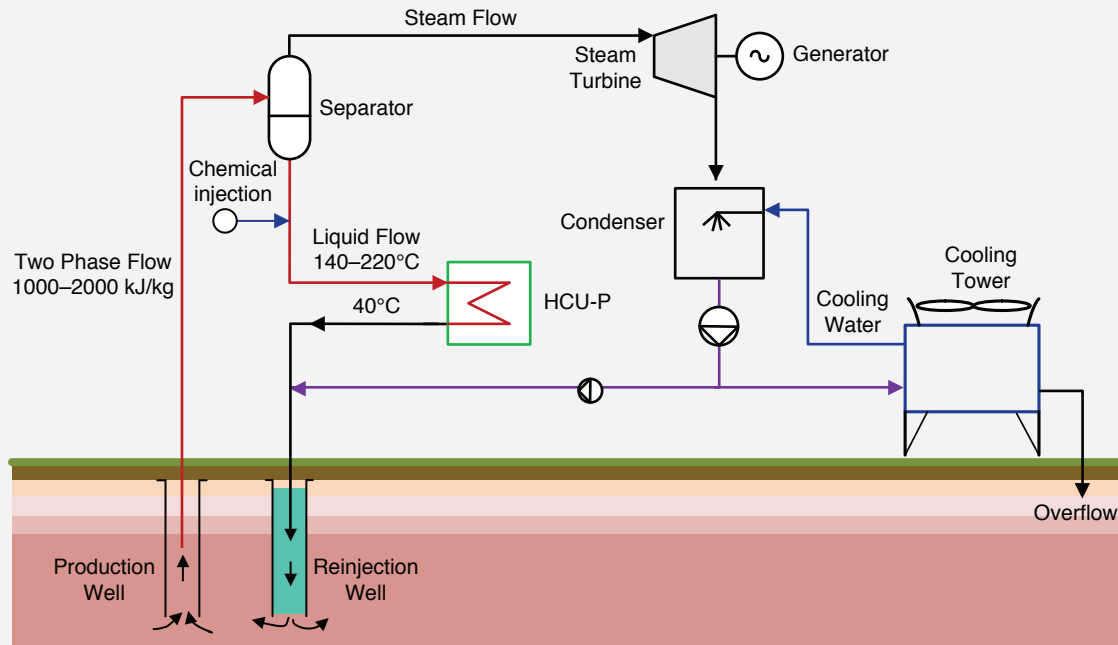

Source: Original figure for this publication.

Note: GPP = geothermal power plant; HCU-P = heat conversion unit, primary side; kJ/kg = kilojoules per kilogram.

**FIGURE 4.7: RATIO OF HEAT POTENTIAL/ELECTRICITY PRODUCED AS A FUNCTION OF ENTHALPY: SINGLE FLASH**

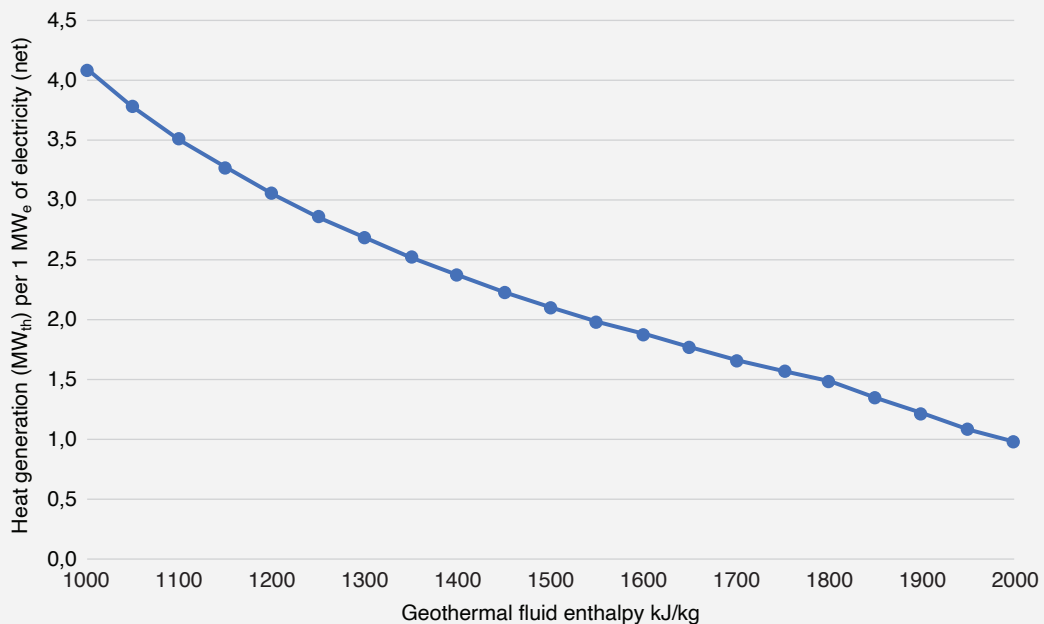

Source: Original calculation for this publication.

Note: kJ/kg = kilojoules per kilogram; MW<sub>e</sub> = megawatt electric; MW<sub>th</sub> = megawatt thermal.

**FIGURE 4.8: RATIO OF HEAT POTENTIAL/ELECTRICITY PRODUCED AS A FUNCTION OF TEMPERATURE: BINARY**

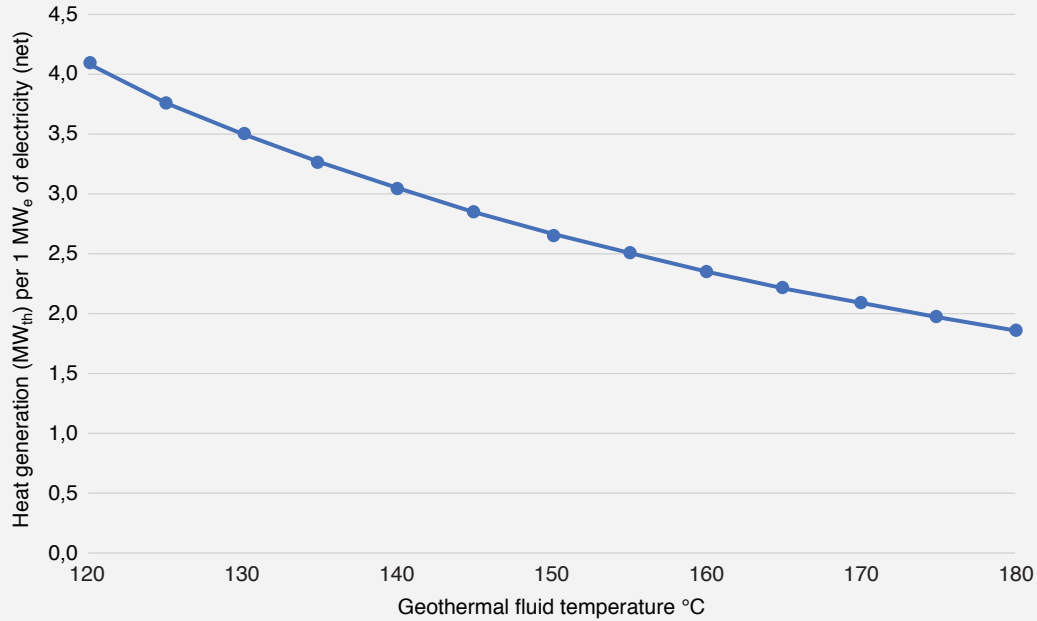

Source: Original calculation for this publication.

Note: MW<sub>e</sub> = megawatt electric; MW<sub>th</sub> = megawatt thermal

For flash power plants when the geothermal enthalpy is the highest, around 2,000 kJ/kg, the heat that can potentially be extracted is the lowest—1MW<sub>th</sub> for 1 megawatt electric (MW<sub>e</sub>). This is because with such enthalpy, as described earlier concerning dry steam GPPs, the fluid is almost pure steam and is mostly used for electricity production, leaving only waste heat on the cold-end side at low temperature.

These figures show that electricity production from geothermal resources can also deliver heat for cogeneration on the so-called waste streams. Major factors limiting the thermal output are the reinjection temperature in the reservoir and the cold-end temperature as a parameter affecting the performance of the turbine for electricity production.

### Cascaded and Integrated Use: Resource Parks

Direct utilization of geothermal resources is highly dependent on the local climate, the characteristics of the geothermal resource, and the local market. However, the efficiency of GDU applications can be quite high, especially when various forms of use are combined in a cascaded arrangement. Cascaded use occurs when a series of downstream users can harness energy released from an earlier process and matching the requirements of the use type with the exit fluid temperature. With such an approach, it is possible to combine some of the applications introduced in the previous sections. Some cascade systems include electricity production and thermal uses, whereas others center on only thermal uses.

Geothermal district heating systems are interesting examples of potential cascaded use (see Box 4.5). For instance, it is possible to combine different neighborhoods and users with different levels of heat requirements. In the case of already existing heating networks, the regime of heat use may not be entirely compatible with the regime recommended for geothermal energy. In a geothermal district heating system where modifications to the existing space heating systems are not feasible, cascaded use can be implemented to combine high-temperature users with lower-temperature users.

Integrated use refers to a utilization scheme that aims to optimize the use of the resource and the investment involved (see Box 4.6). This is accomplished by finding uses for the geothermal heat installed in a district heating application outside the heating season.

Integrated or cascaded use of the resource in one location is often referred to as geothermal resource park, geothermal industrial park. Examples of geothermal industrial parks can be found in Iceland (see Box 4.7), Kenya and New Zealand to mention a few.

The pros, cons, and key environmental and social aspects of the direct use systems outlined in this section are summarized in Table 4.2.

## KEY COMPONENTS AND COSTS

A geothermal system consists of multiple components that can be categorized into production, transport, heat central, distribution and end user. Depending on the complexity of the application, the components may vary. The key components of a typical GDU system are described in the following section.

### Wells

Geothermal production wells can be from few meters deep well down to 4 to 6 km depth, depending on the location of the targeted resource. Wells are nowadays mostly drilled either with a standard diameter (with a production casing of 9 5/8 inches) or with a large diameter (with a production casing of 13 3/8 inches). To increase the output of highly productive wells, a 20-inch pump chamber casing in the upper part of the production casing is often installed when pumps are larger than 12 inches.

The design conditions of wells drilled for utilizing low- to medium-temperature geothermal fluid are usually less demanding than wells drilled for high-temperature fluid. The temperature is lower, and usually the pressure is lower as well; the flow is in liquid form (no steam), the volume flow is lower, and the fluid chemistry is usually less aggressive. The hot water may contain gas, which may involve additional requirements for the pump installation in operation and, in some geothermal resources, wells must be designed for gas kicks that might occur during drilling. In areas where the hot water is produced from a reservoir containing sand, sand control is required to protect the pump and other equipment.

## BOX 4.5: CASCADED USE OF GEOTHERMAL IN HÚSAVÍK, ICELAND

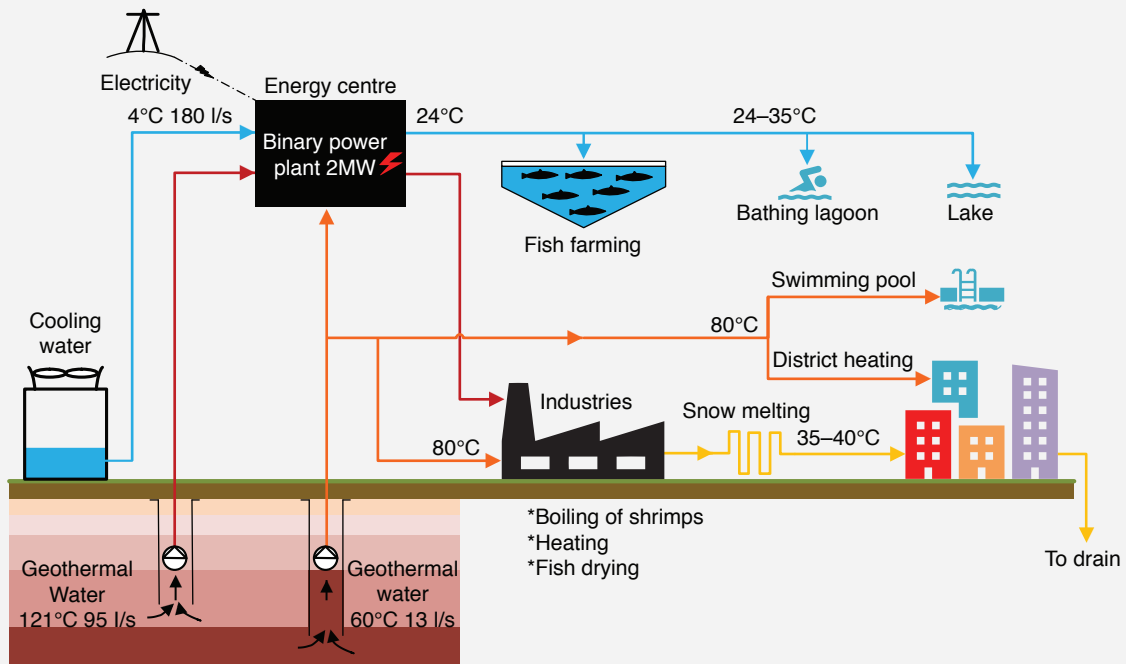

Note: l/s = liters per second; MW = megawatt.

Húsavík is a town located in northeast Iceland. The Hveravellir geothermal area, about 20 km south of Húsavík, has been used since the early 1970s for district heating. In the 1990s, the system was renovated and the use of the geothermal fluid, resulting in a change of operation across the entire system and in the construction of a geothermal power plant.

Geothermal water at 125°C from the Hveravellir geothermal field is piped more than 16 km to the power plant, where it is used for electricity production by cooling in a heat exchanger from 121°C down to 80°C. The fluid is then transferred to a storage tank. From there, the geothermal fluid is piped to Húsavík, where it is used for multiple purposes, including district heating, drying of fish products, fish farming, boiling shrimp, melting snow, thermal bathing, and swimming pools.

Once the geothermal fluid has been harnessed for electricity production, about 97 kilograms per second of 80°C hot water and 200 kilograms per second of 30°C cooling water are available for the district heating system as well as for potential use in various types of food production or other uses. Today, all the water extracted from the geothermal field is first used for electricity production. However, if a potential market opens for the industrial use of hot water, the system has been designed in such a way that it is possible to bypass the power production and switch it to industrial use at any time.

Source: Original figure for this publication.

## BOX 4.6: INTEGRATED USE OF GEOTHERMAL IN REYKJANES, ICELAND

The geothermal resource park concept associated with the Reykjanes and the Svartsengi Geothermal Power Plant (GPP) in Iceland offers one of the best examples of the cascaded and integrated use of geothermal energy. The main products and areas of operation of the park include hotels, thermal baths, fish drying, fish farming, wellness tourism, and the production of methanol, algae, and cosmetics. These are made possible by substances present in the geothermal resource as well as those used by the GPP, such as freshwater and seawater.

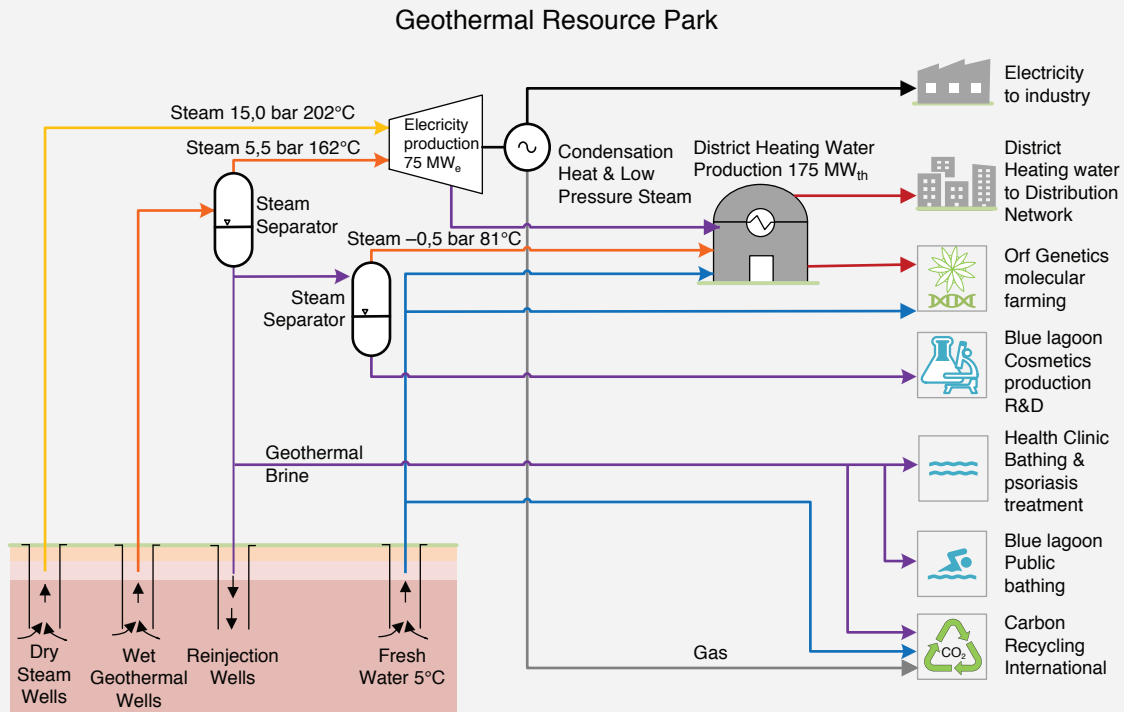

Source: Original figure for this publication.

Note: CO<sub>2</sub> = carbon dioxide; MW<sub>e</sub> = megawatt electric; MW<sub>th</sub> = megawatt thermal; R&D = research and development.

The revenue streams created by GPPs include:

- Electricity
- Geothermal water/brine (incl. mineral extraction)
- Geothermal steam
- Hot water
- Cold water
- CO<sub>2</sub>



#### **BOX 4.6: INTEGRATED USE OF GEOTHERMAL IN REYKJANES, ICELAND (Continued)**

The Svartsengi geothermal field has been actively developed since the 1970s through Hitaveita Suðurnesja, a public company. The initial goal was to produce hot water for adjacent communities and operate a small GPP to generate electricity for the district heating system's own consumption. This company has since been divided, to align with regulations. Today, HS Orka operates the Svartsengi and Reykjanes plants with a capacity of 100 MW<sub>e</sub> at Reykjanes and 75 MW<sub>e</sub> and 175 MW<sub>th</sub> at Svartsengi. HS Veitur operates various district heating systems, including those connected to geothermal power plants. HS Orka is now a private company.

New opportunities evolved from the initial GPPs. Shortly after the start of operations at Svartsengi, the lagoon formed by the geothermal fluid discharged by the plant soon became a popular bathing place (Box 2.12).

Geothermal cogeneration was applied to Iceland's important fishing and fish processing sector. Fish preservation is a key element of this approach and the country has moved from the traditional use of drying in the open air to that of dryers using geothermal steam. Haustak is an example of this approach, as various fisheries' by-products are dried with the energy provided by the Reykjanes GPP. The company is thus promoting products that would otherwise be wasted, once again illustrating the geothermal park concept of a waste-free society.

#### **BOX 4.7: THE ROLE OF GEOTHERMAL PARKS IN WASTE REDUCTION IN ICELAND**

Geothermal energy requires further research and development to expand the usage and optimize processes. The geothermal park in Reykjanes has enabled the development of biotechnology start-ups such as ORF Genetics and innovative companies such as Carbon Recycling International, dedicated to the production of methanol. CO<sub>2</sub> is extracted to enrich the atmosphere of structures intended for the production of algae or for greenhouses. Innovative concepts are being developed to optimize the extraction of energy from power plants and the extraction of CO<sub>2</sub> for various purposes.

The concept of a waste-free society that underlies the development of geothermal resource parks is not so obvious in the context of companies dedicated to energy production and in a context where economic activities are more or less restricted to a certain sector. More than four decades after the start of energy production operations in Svartsengi, the economic impact of geothermal activities on the Reykjanes Peninsula is self-evident. While the Svartsengi and Reykjanes plants directly employ about 60 people, the activities developed around the geothermal resource directly employ 500 people and it is estimated that around 600 additional indirect jobs are related to geothermal energy in the Reykjanes.

In 2013, from revenues of about €130 million generated by the resource park, about 60 percent was generated by HS Orka and HS Veitur, with an additional 24 percent generated by the Blue Lagoon. The additional 15 percent of income is related to the diversification of the use of geothermal energy. Apart from the fact that this diversification brings with it new sources of income, it also spreads the risks involved, to the advantage of the geothermal operator.

**TABLE 4.2: COMPARISON OF VARIOUS GEOTHERMAL UTILIZATION SYSTEMS**

	<b>PROS</b>	<b>CONS</b>	<b>ENVIRONMENTAL AND SOCIAL ASPECTS</b>
Self-flowing artesian hot spring	Low cost, no drilling  Technically simple solution	Use must be scaled to existing artesian flow and temperature	Sustainable use  The hot spring might be part of special protected natural features and therefore not exploitable  In some places, the resource has been long exploited by local communities
Self-flowing drilled wells	Enhanced productivity	Cost of drilling	Sustainable use
Pumped production wells	Enhanced production to the extent permitted by the resource	Cost of drilling and operational cost of pumping  Requires greater resource assessment and more sophisticated engineering	Sustainable use if the natural recharge of the reservoir is in equilibrium with the exploitation/ extraction (flow and temperature)  Sustainability might be an issue depending on exploitation pattern
Pumped production wells with reinjection	Replenishment of the resource is taken into account	Cost of drilling and operational cost of pumping	Sustainable use if the natural recharge of the reservoir and reinjection are in equilibrium with the exploitation (flow and temperature)
Combined production	Enhanced utilization of the resources without extensive additional costs	Issues related to chemistry of the high-enthalpy geothermal resources  Operation of the cogeneration of electricity and heat for combined production (e.g., maintenance requirements and effects on downstream uses)	Sustainable use if the natural recharge of the reservoir and reinjection are in equilibrium with the exploitation (flow and temperature)
Cascaded and integrated use	Enhanced utilization of the resources without extensive additional cost	Issues related to chemistry of the high-enthalpy geothermal resources	Sustainable use if the natural recharge of the reservoir and reinjection are in equilibrium with the exploitation (flow and temperature)

Source: Original compilation for this publication.

The open-hole production section of wells, drilled to extract low- or medium-enthalpy fluid, can vary from 6 1/2 inches in diameter or smaller, up to 12 1/2 inches. Large-scale utilization of geothermal fluid from sedimentary basins requires, almost without exception, reinjection to create sustainable operating conditions. The reinjection rate generally depends on the characteristics of the resource and on the intended production and uses. A sound resource management practice is to have a 1:1 production to injection well ratio at the initial stages of utilization, where the extraction rate of a production well is similar to the reinjection rate of the reinjection well. The ratio can also be 2:1, 3:1, or higher if the natural recharge of the system is good compared to the production rate, implying a lower reinjection rate because the field is renewed from other geothermal sources. A set of one production well and a matching reinjection well is usually called a geothermal doublet; two production wells and a single reinjection well is called a triplet, and so on.

### Well Pumps

If pumping is required, the design of the production well must allow for a downhole pump located below the dynamic water level, taking in account the bubble and/or boiling point. The casing diameter must be large enough for the pump, and often this is solved by having a pump chamber in the well. The size of these downhole pumps is usually 6 to 12 inches and requires a casing diameter of 9 5/8 to 13 3/8 inches. Table 4.3 summarizes the well size, pump size, and technical output of both the line shaft as well as the submersible pump. The resource will determine the final output.

The selection of well pumps is based on analysis of various factors related to the operation of the system and its performance: price, space in the well, temperature rating, efficiency, installation depth, and material selection. Two types of well pumps are currently used in geothermal applications: line shaft pumps and electrical submersible pumps.

The motor in line shaft pumps is located at the surface, on top of the well head, while the pump is installed in the well. The pump casing is connected to the well head with a riser pipe to bring the water to the surface. A rotating shaft from the motor is in the center of the riser pipe and spins the impellers in the pump casing. In most geothermal applications, the shaft bearings are lubricated with an external fluid and the shaft is enclosed by a lubricating tube.

**TABLE 4.3: LOW-TEMPERATURE GEOTHERMAL WELLS: SIZE AND OUTPUT**

	PRODUCTION CASING	LINE SHAFT PUMP 3,000 RPM		SUBMERSIBLE PUMPS 3,600 RPM	
	SIZE (INCHES)	SIZE (INCHES)	OUTPUT (KG/S) <sup>a</sup>	SIZE (INCHES)	OUTPUT (KG/S)
Standard diameter well	9 5/8	8	38	6	77
Large diameter well	13 3/8	10	77	8	115
Large diameter well with a large pump chamber	13 3/8 to 16	12	115	10	192

Source: Original compilation for this publication.

Note: <sup>a</sup>For 100°C water temperature. kg/s = kilograms per second; rpm = rotation per minute.

The motor in electrical submersible pumps is submerged in the geothermal fluid below the pump. In this case, the motor is connected to the pump with a relatively short driving shaft. A riser pipe connects the pump to the surface to bring the water up.

Formerly, well pumps were fixed speed pumps that ran at 1,500 to 3,000 rpm (rotation per minute); now they are often driven with a variable frequency drive that allows operation at 1,500 rpm to 3,600 rpm. Pump selection for a specific well may require a narrower operation window, such as 2,800 to 3,600 rpm, for better performance under given operational conditions.

Although the inflow and outflow of geothermal fluid occurs close to the lower part of the wells, well pumps are installed in the upper part of the well. They are situated under the static liquid level but deep enough to be submerged under the dynamic fluid level, caused by the well draw down when pumping. It should be noted that the dynamic fluid level can be considerably lower than the static liquid level.

### Transport and Distribution

The method to transport geothermal fluid depends on the intended use. A single-pipe system is an open system using the geothermal fluid directly, say for a hot spring or pool. It is more economical than a double-pipe system but can only be applied in cases when sustainable resource utilization does not require reinjection. To transport geothermal fluid from a geothermal field to a heat central or end user, a double pre-insulated piping system is the common choice.

Geothermal heat or water can easily be transported over long distances. In 1945, Iceland's longest transport pipeline was 15 km long, using two 350-millimeter (mm) pipes; in 1980, a 60-km pipeline of 400 to 450-mm piping main was constructed. Heat loss and temperature drops can easily be calculated and are in most cases minimal. The main driving factors determining whether it is economical to transport geothermal fluids are the cost of harnessing the geothermal heat, energy price, amount of water flowing, annual utilization hours, cost of pumping, and land rights.

The pipes from the production wells must be flexible enough to allow thermal expansion but also stiff enough to withstand operational load action. Depending on the location of the project and environmental and safety restrictions, the pipes can be installed above ground or buried in trenches that are backfilled with fine sand and excavated material.

The pipe material must be chosen taking into consideration the characteristics of the geothermal fluid but can usually either be plastic (PPR or PEX) or carbon steel. If the pipes are not bought pre-insulated, insulation must be provided separately to avoid heat loss during transmission. The most common insulation materials are mineral wool or polyurethane foam. Pipes can be readily bought from various suppliers globally.

### Heat Centrals

A heat central functions as a connection point between the geothermal production and the distribution system. It receives energy from the geothermal fluid and transmits it to the distribution system via a heat exchanger and a pumping system.

Various heat central systems can be used to provide end users with hot water. Geothermal resources can be combined with other sources of energy at the heat central to supply energy to a district energy system

depending on the size of the system and resource availability. It is also often more economical to use an additional source of energy for peak periods when the demand is high.

The components selected in a heat central are dependent on the characteristics of the geothermal fluid and type of utilization. The most common components used in heat centrals are described below.

## **Heat exchangers**

A heat exchanger is generally needed for the GDU systems, although there are exceptions to this rule, such as in systems where the fluid is suitable for utilization directly within the surface application and reinjection of the geothermal fluid can either be accommodated after the application or is not required.

Of the various types of heat exchangers available, the best choice depends on the characteristics of the geothermal fluid and the end use within the intended surface application. The types of heat exchangers often used within geothermal heating applications are plate heat exchangers or, in some cases, shell and tube heat exchangers. Multiple manufacturers provide heat exchangers, and they are considered widely accessible globally.

The plate heat exchanger tends to be both more compact and less costly than the shell and tube heat exchanger and therefore is often preferred. Plate heat exchangers are more flexible as more plates can be added if needed, plus they are relatively easy to clean. Plate thickness and number are based on the heat flow and characteristics of the geothermal fluid. A typical requirement is a minimum of 0.5 mm thickness. Shell and tube heat exchangers are mainly selected if the fluid pressure is high, gas may be an issue, and scaling is expected. As for all components, the composition of the geothermal fluid is a key parameter influencing the selection of the equipment.

## **Pumps**

Circulation or booster pumps are needed for the distribution heating system to circulate the secondary heating fluid in case of a closed-loop system. Circulation pumps are proven, standard products available from many manufacturers. A control system for the pumps and other required components can be placed in the heat central.

## **Electrical and control system**

The pumps operate on electricity and require a connection. For regulating and monitoring purposes, it is recommended that flow measuring units, temperature, and pressure sensors be placed at the production wellheads and in the heat-exchanger lines of district heating systems.

It is recommended that a supervisory control and data acquisition (SCADA) network and a programmable logic controller with remote control options be installed in relation to the system size, design, and operation plans. Electrical and control systems are a proven technology available from global manufacturers. A suggested requirement is that the materials selected be able to withstand the geothermal environment or be protected by air-pressured containers.

## **Peak Facilities: Heat pumps and gas boilers**

In many applications, heat pumps and gas boilers are needed to secure the economy of systems. This is often the case if the annual number of utilization hours of maximum heating power is less than about 3,000. The cost of harnessing the geothermal water and long transportation pipelines are key factors to optimizing the combination of additional and peak power sources. A comprehensively designed geothermal

system includes heat pumps and peak boilers (if needed) and can have significant capital cost savings of up to 50 percent.

Heat pumps are used to transfer heat from one medium, the source, to another, the heat sink, and require external energy to drive the process; in most cases this is electricity. Heat pumps can be used to lower the return temperature of the geothermal loop and optimize heat extraction from the geothermal fluid while providing considerable extra energy units to the overall system. The efficiency of each heat pump can be calculated with the coefficient of performance (COP), which is the ratio of heat provided by the source to the energy required:

$$COP_{heating} = \frac{Q_{sink}}{W_{electricity}}$$

Where:

$Q_{sink}$  [kW] is the thermal heat delivered by the heat pump and

$W_{electricity}$  [kW] is the electrical power needed to drive the process (electrical energy bought from the net).

COP values of above 4 are quite common for this type of application, which means that for each unit of electricity that is provided to drive the heat pump, about four units of energy are delivered to the system in the form of heat. Many factors, such as electricity cost, investment cost, characteristics of the geothermal system, and the energy profile of the users must be weighed when fine-tuning the design of the district energy systems with such equipment.

Regarding cooling with geothermal heat, absorption chillers may be operated with geothermal fluid at temperatures of 85°C and above to drive the process instead of electricity. This is not to be confused with ground source heat pumps used for space cooling.

### Levelized cost of heat

Investment costs vary greatly between direct-use applications and also depending on how and where the energy is harnessed, processed, and distributed. One cannot easily define standard costs, however, examples are provided in Annex A to demonstrate how levelized cost of heat (LCOH) is calculated for geothermal heat, as well as geothermal district heating projects. Annex A shows that the prices for heat sales can be as low as \$14/MWh and as high as \$51/MWh, depending on the cost and capacity factor. For district heating systems, the price range is \$28 to \$100/MWh. In the United States, the LCOH for district heating assumes a 30-year lifetime, 5 percent discount rate, and overnight construction ranges of \$15 to \$105/MWh depending on location, capacity factor, and resource, with an average of \$54/MWh (NREL 2021). For example, if the heating required is 50 W/m<sup>2</sup>, the cost may be estimated at \$400 to \$1,200/kW, depending on the size of the space, which is in line with the estimated cost. Similarly, a small 10 MWth and 1 MWe plant in Austria delivers heat to district heating consumers for \$27 to \$44/MWh (Lund 2012).

## PROJECT PREPARATION

The previous section discussed how the enabling environment contributes to the success of a project, but how a project is prepared is equally important. Preparation of a geothermal project is often a long process that may involve up to 30 percent of the capital expenditure needed before the resource has been proven

(highly dependent on drilling needs and available infrastructure). Therefore, it is of great importance to perform the project preparation in a systematic and disciplined way to maximize the chances of making informed decisions.

The necessary effort to complete a geothermal projects varies, corresponding to its size and complexity. However, all geothermal project development, whether GDU or co-generation, involves similar project states, see Figure ES.6. After each stage it is essential that a decision is made whether to carry on with the project or not. It is therefore essential that all stakeholders in the project are clear on the project goals, risk and decision points. It should be noted that for ground source heat pumps system for a single house the project preparation starts at Project design stage after the project feasibility has been evaluated.

The illustrated gate stage process for geothermal direct-use projects is presented both for an individual GDU project as well as for cogeneration. As demonstrated, there is a difference in the preparation for the projects, their complexity, and the required tasks, but the stages are essentially the same. Explanations for each stage are given in Box 4.8.

#### BOX 4.8: STAGE GATE PROCESS FOR GEOTHERMAL PROJECTS: EXPLANATIONS

The initial **reconnaissance** stage generally involves an inexpensive desk study that provides an overview of all available information and outlines what types of surface exploration are required to fill in any information gaps. At this stage it is also important to consider utilization, not only from the market and technical viewpoints but also from social and environmental contexts. A successful project will integrate all these aspects to provide the most value for all stakeholders, including members of the local community. Conducting a thorough market analysis or heating/cooling demand analysis is essential for geothermal direct-use projects. The analysis can be conducted across the reconnaissance and prefeasibility stages, but the feasibility stage cannot be finalized without thorough market analysis and/or contracts for the purchase of heat.

The **prefeasibility** stage starts with surface exploration and the initial resource assessment and identification. Models integrating other activities that might benefit from some by-products of geothermal energy should also be investigated early in the prefeasibility stage to make sure these activities can be easily integrated into the process, to enhance the business case and optimize resource utilization.

During the **feasibility** stage, the developer must invest in exploration wells (if drilling is required). In addition, an EIA (often including a social assessment)—and, as mentioned, a market analysis and/or contracts—need to be finished, a feasibility design completed, and various other tasks handled that will eventually form the feasibility study (ESMAP 2021).

At the **project design** stage, the detailed design is made, tender documents are prepared, and the remaining rights and permits are applied for and finalized.

The cost of the **construction** stage in direct-use geothermal application is still significant, but it comes at a time when the project is well defined and its overall risk is significantly lowered (Pálsson 2017).

During the **operation** stage, it is essential to continue monitoring the resource and maintaining the equipment according to best practices.

This stage gate approach is a simple way to manage up-front risks. Carefully planning the development activities and conducting a project in incremental steps will also contribute to enhancing the credibility of a project for potential financiers and lenders. During project preparation, one of the decisions to make is whether to develop the geothermal resource in a single phase or in multiple phases (for definitions, see Box 4.9).

From a financing point of view, each stage of a geothermal project has a unique set of resource risks, capital demands, and operational challenges. Thus, financing is typically raised on a stage-by-stage basis (see Figure 4.9) from various types of investors and may employ a range of financial structures (see Table 4.4) and financial incentives and support mechanism (see section 3). Relatively high up-front investment costs, as well as potential risks related to uncertainty about resource quality, can present challenges for financing GDU compared to projects that derive heat from fossil fuels or bioenergy. Whether to employ a single-phase or multiphase approach has to be considered not only from a resource point of view but

#### BOX 4.9: DEVELOPING A GEOTHERMAL RESOURCE IN ONE OR MORE PHASES

With a single-phase approach, a geothermal project is developed to the maximum size that the geothermal field is believed to be able to support, which is generally greater than 50 percent of the estimated capability.

With a multiphase approach, a geothermal resource is utilized in several relatively small phases. The resource risk is minimized by sizing the first phase significantly below half the estimated capability of the resource, essentially holding the rest in reserve. The project then proceeds to the next phase based on the experience of the previous phase.

Each of the two approaches has its own benefits, as summarized here:

##### BENEFITS OF SINGLE-PHASE DEVELOPMENT

- Lower capital expenditure (CAPEX) per megawatt thermal ( $MW_{th}$ ) due to economies of scale as a result of lower:
  - Cost of drilling each well
  - Cost of equipment
  - Cost of common infrastructure
- Lower operating expenditure (OPEX) per  $MW_{th}$
- Fewer employees per  $MW_{th}$
- High output of energy
- Financing often easier due to scale

##### BENEFITS OF MULTIPHASE DEVELOPMENT

- Shorter timeline as each phase is smaller in scale
- Full utilization reached in shorter time
- Results from the previous operation used to decide on
  - Additional applications
  - Application scale-up
- Resource capability (e.g., chemistry, reinjection, production)
- Lower risk of failure

**Source:** Original compilation for this publication



**FIGURE 4.9: STAGE GATE PROCESS FOR GEOTHERMAL PROJECTS**

*Geothermal Direct-Use Project: Cogeneration or Industrial Park*

Reconnaissance	Pre-feasibility	Feasibility	Project design	Construction	Operation
<ul style="list-style-type: none"> <li>• Desk study</li> <li>• Market analysis/heating and cooling demand analysis</li> <li>• Preliminary E&amp;S study</li> <li>• <b>Decision to proceed</b></li> </ul>	<ul style="list-style-type: none"> <li>• Preliminary review of available resources</li> <li>• Pre-feasibility report</li> <li>• <b>Decision to proceed</b></li> </ul>	<ul style="list-style-type: none"> <li>• Due diligence on the resource assessment and resource management</li> <li>• Technical due diligence</li> <li>• ESIA</li> <li>• Feasibility study</li> <li>• Financial close</li> <li>• <b>Decision to tender</b></li> </ul>	<ul style="list-style-type: none"> <li>• Tender design</li> <li>• Tendering and procurement</li> <li>• Financial analysis</li> <li>• <b>Decision to Construct</b></li> </ul>	<ul style="list-style-type: none"> <li>• Detail design</li> <li>• Construction and supervision</li> <li>• Commissioning</li> </ul>	<ul style="list-style-type: none"> <li>• Maintenance</li> <li>• Refurbishment</li> <li>• Operation</li> <li>• <b>Decision to decommission</b></li> </ul>

*Independent Geothermal Direct Use Project*

Reconnaissance	Pre-feasibility	Feasibility	Project design	Construction	Operation
<ul style="list-style-type: none"> <li>• Desk study</li> <li>• Surface Exploration</li> <li>• Exploration report</li> <li>• Market analysis/heating and cooling demand analysis</li> <li>• Preliminary E&amp;S study</li> <li>• <b>Decision to proceed</b></li> </ul>	<ul style="list-style-type: none"> <li>• Exploration program</li> <li>• Exploration/test drilling</li> <li>• Reservoir assessment</li> <li>• Pre-feasibility report</li> <li>• <b>Decision to proceed</b></li> </ul>	<ul style="list-style-type: none"> <li>• Confirmation drilling (if needed)</li> <li>• Reservoir engineering</li> <li>• ESIA</li> <li>• Feasibility study</li> <li>• Decision to tender</li> <li>• Financial close</li> <li>• <b>Decision to tender</b></li> </ul>	<ul style="list-style-type: none"> <li>• Tender design</li> <li>• Tendering and procurement</li> <li>• Financial analysis</li> <li>• <b>Decision to Construct</b></li> </ul>	<ul style="list-style-type: none"> <li>• Detail design</li> <li>• Construction and supervision</li> <li>• Commissioning</li> </ul>	<ul style="list-style-type: none"> <li>• Monitoring</li> <li>• Maintenance</li> <li>• Make up drilling (if needed)</li> <li>• Refurbishment</li> <li>• Operation</li> <li>• <b>Decision to decommission</b></li> </ul>

Source: Original compilation, adoption of Pálsson 2017 to GDU projects.

Note: Ground source heat pumps for single house will start at project design after the feasibility has been evaluated.

also from a financing point of view as private financing is often not available or is expensive for small- to mid-size projects.

The return on investment of a geothermal project is linked to the project's capital cost, timeline for development, necessary infrastructure, price of power, and expected revenues. At the early stages, however, the potential return on investment must be weighed against the probability that no viable geothermal resource will be discovered. Those projects that go through all stages will efficiently and effectively minimize resource uncertainty as much as possible, thereby reducing the cost of capital (International Geothermal Association 2014). Knowing the capacity of a geothermal resource with sufficient certainty, that is, when the available capacity estimate can be considered proven, will improve the possibility of the commercial financing of a geothermal project.

Geothermal projects that have the possibility to develop different direct-use applications might have higher up-front costs for exploration and construction, but once a viable location has been identified, they offer greater, more diversified revenue streams. This opens up business opportunities for GDU but requires a thorough analysis of the market for demands: current and prospect.

The **developer's responsibility** is to ensure sufficient project preparation by following the stage gate approach. The developer must ensure best practices in conducting studies to evaluate the geothermal

**TABLE 4.4: FINANCING OPTIONS FOR THE DIFFERENT STAGES OF A GEOTHERMAL PROJECT**

DEVELOPMENT STAGE	% OF TOTAL CAPEX	FINANCING OPTIONS
Reconnaissance	<5%	<ul style="list-style-type: none"> <li>• Balance sheet financing by larger developers</li> <li>• Private equity</li> <li>• Government</li> <li>• Concessional funds from international donors</li> <li>• Multilateral development agencies and banks</li> </ul>
Prefeasibility	~10%	<ul style="list-style-type: none"> <li>• Balance sheet financing</li> <li>• Private equity</li> <li>• Investment funds</li> </ul>
Feasibility	~20%	<ul style="list-style-type: none"> <li>• Public markets</li> <li>• Financial/strategic partners</li> <li>• Concessional funds from international donors</li> </ul>
Project Design	~20%	<ul style="list-style-type: none"> <li>• Government</li> <li>• Multilateral development agencies and banks</li> </ul>
Construction	~45%	<ul style="list-style-type: none"> <li>• Construction debt</li> <li>• Long-term debt from international financial institutions</li> <li>• Multilateral development agencies and banks</li> <li>• Export credit agency financing</li> </ul>
Operation	OPEX	<ul style="list-style-type: none"> <li>• Commercial banks</li> <li>• Financial institutions</li> <li>• Large producers</li> </ul>

resource, environmental compliance, market analysis and technical design as well as ensure engagement with stakeholders to demonstrate the benefits of the project and to minimize the risk of local opposition. Ensuring compliance with best practices for technical, environmental, and social aspects will improve access to financing. The financing requirements will depend on project type, size, structure, and location; the capacity of the developer; and the risk appetite of financiers. At the early stages, however, the potential return on investment has to be weighed against the probability that no viable geothermal resource will be discovered.

## REFERENCES

- AEBIOM (European Biomass Association), EGEC (European Geothermal Energy Council), and ESTIF (European Solar Thermal Industry Federation). 2017. "Renewable Heat Sources: The Best Available Solution to Decarbonise the Heating Sector." Joint position paper, May. [http://www.estif.org/fileadmin/estif/Electrification-HC\\_AEBIOM-EGEC-ESTIF\\_April-2017-1.pdf](http://www.estif.org/fileadmin/estif/Electrification-HC_AEBIOM-EGEC-ESTIF_April-2017-1.pdf).
- Aksoy, N., O. S. Gok, H. Mutlu, and G. Kılınc. 2015. "CO<sub>2</sub> Emission from Geothermal Power Plants in Turkey." Proceedings of World Geothermal Congress 2015, Melbourne, Australia, April 19 to 25, 2015.
- Arason, Sigurjon. 2003. "The Drying of Fish and Utilization of Geothermal Energy—The Icelandic Experience." International Geothermal Conference 2003. [https://www.researchgate.net/publication/228467215\\_The\\_Drying\\_of\\_Fish\\_and\\_Utilization\\_of\\_Geothermal\\_Energy\\_-\\_The\\_Icelandic\\_Experience](https://www.researchgate.net/publication/228467215_The_Drying_of_Fish_and_Utilization_of_Geothermal_Energy_-_The_Icelandic_Experience).
- Arctic Green Energy. n.d. "Projects: Arctic Green Energy in China." <https://arcticgreencorp.com/projects/>.
- Arekapudinayda, N., and N. L. Almodóvar-Reteguis. 2020. "Women's Property Rights Are the Key to Economic Development." World Bank blog, February 24, 2020. <https://blogs.worldbank.org/developmenttalk/womens-property-rights-are-key-economic-development>.
- Blue Lagoon. n.d. <https://arsskyrsla2019.bluelagoon.is/en/mannaudur/>.
- Carbon Recycling International. n.d. "Carbon Dioxide to Methanol since 2012." <https://www.carbonrecycling.is/>.
- Darnet et. al 2020, "Defining best practices in the management of geothermal exploration data", World Geothermal Conference, Reykjavik 2021.
- DINOloket. n.d. "Data and Information on the Dutch Subsurface." <https://www.dinoloket.nl/en>.
- EGEC (European Geothermal Energy Council). 2017. "First Greenhouse for Algae Cultivation Heated by Geothermal Plant Launches Today." October 13, 2017. <https://www.egec.org/first-greenhouse-algae-cultivation-heated-geothermal-plant-launches-today/>.
- EIA (US Energy Information Administration). 2021. "Carbon Dioxide Emissions Coefficients." [https://www.eia.gov/environment/emissions/co2\\_vol\\_mass.php](https://www.eia.gov/environment/emissions/co2_vol_mass.php).
- ESMAP. 2012. *Geothermal Handbook: Planning and Financing Power Generation*. Washington, DC: World Bank.
- ESMAP. "2016 World Bank Group." 2016. *Comparative Analysis of Approaches to Geothermal Resource Risk Mitigation: A Global Survey*. ESMAP Knowledge Series 024/16. Washington, DC: World Bank.
- ESMAP. 2018. *Opportunities and Challenges for Scaling-Up Geothermal Development in Latin America and the Caribbean Region*. Washington, DC: World Bank.
- ESMAP. 2019. *Gender Equality in the Geothermal Energy Sector: Road to Sustainability*. Knowledge Series 028/19. Washington, DC: World Bank. <https://openknowledge.worldbank.org/handle/10986/31607>.
- ESMAP. 2021. *Preparing Feasibility Studies for the Financing of Geothermal Projects: An Overview of Best Practices*. Washington, DC: World Bank. [https://www.esmap.org/preparing\\_feasibility\\_studies\\_for\\_financing\\_geothermal\\_proj](https://www.esmap.org/preparing_feasibility_studies_for_financing_geothermal_proj)
- European Commission. 2020. "Decision C (2020) 257 final, dated 20 January 2020." [https://ec.europa.eu/competition/state\\_aid/cases1/202016/277988\\_2147718\\_154\\_5.pdf](https://ec.europa.eu/competition/state_aid/cases1/202016/277988_2147718_154_5.pdf).

- European Commission. n.d. "Intelligent Energy Europe: Projects Database." [https://ec.europa.eu/energy/intelligent/projects/sites/iee-projects/files/projects/documents/gtr-h\\_final\\_gtr\\_h\\_framework.pdf](https://ec.europa.eu/energy/intelligent/projects/sites/iee-projects/files/projects/documents/gtr-h_final_gtr_h_framework.pdf).
- FAO (Food and Agriculture Organization). 2011a. *Global Food Losses and Food Waste: Extent, Causes and Prevention*. Rome: FAO. <http://www.fao.org/docrep/014/mb060e/mb060e.pdf>.
- FAO. 2011b. Energy-smart food for people and climate. Issue Paper, Food and Agriculture Organization. Rome. [www.fao.org/3/i2454e/i2454e.pdf](http://www.fao.org/3/i2454e/i2454e.pdf)
- FAO. 2015. *Uses of Geothermal in Food and Agriculture: Opportunities for Developing Countries*. Rome: FAO. <http://www.fao.org/3/a-i4233e.pdf>.
- FAO. 2017. *The Future of Food and Agriculture: Trends and Challenges*. Rome: FAO.
- FAO. 2021. *The Impact of Disasters and Crises on Agriculture and Food Security: 2021*. Rome: FAO. <https://doi.org/10.4060/cb3673en>.
- Flóvenz, Ólafur G. 2012. "Phases of Geothermal Development." Presentation at the Renewable Energy Training Program, Module 3: Geothermal Energy, World Bank, Washington, DC. <https://esmap.org/sites/default/files/esmap-files/Flovenz%20Day%201%20-WB-2-phases-final.pdf>.
- GAMMA. 2015. "Fjölpætt nýting jarðvarma á Reykjanesskaga." [In Icelandic]. <https://www.gamma.is/frettir/nr/1455>.
- GEOENVI Project. 2021. "Local benefits, good practices from Italy." <https://www.geoenvi.eu/wp-content/uploads/2021/02/geoenvi-wp4-local-benefits-in-italy-torsello-20210316.pdf>.
- GEOFOOD Project. 2020. "Geothermal Energy for Circular Food Production." <https://geofoodproject.eu/wp-content/uploads/2020/09/Geothermal-energy-for-circular-food-production-%E2%80%93-GEOFOOD.pdf>.
- GEOFOOD Project. n.d. "Greener Way to a Better World." <https://geofoodproject.eu/>.
- GEOFOOD Project 2021. "GEOFOOD – Additional heat utilization process for geothermal aquaponics", Alexander Boedijn, Alexander van Tuyl van Serooskerken, Esteban Baeza Romero, Eric Poot and Carlos Espinal. Report WPR-1100.
- Gissurarson M., and F. Georgsson. 2015. *Use of Geothermal Resources for Drying of Agricultural Commodities in East Africa*. Report 03-15. Reykjavík, Iceland: Matis. ISSN: 1670-7192.
- Global Wellness Institute. 2018. "Hot Springs with Spa Services Generate Roughly Twice the Revenues as Those Without—Even Though They Only Represent a Third of Facilities." Global Wellness Institute blog, March 18, 2018. <https://globalwellnessinstitute.org/global-wellness-institute-blog/2015/03/18/2015-3-18-hot-springs-global-revenues-50-billion/>.
- Government of Kenya. 2008. "Vision 2030, Big Four Agenda." <https://vision2030.go.ke/towards-2030/>.
- Guðmundsson, Snæbjörn. 2016. "Hver er saga Deildartunguhvers?" Flokkar, October 19, 2016. <https://www.visindavefur.is/svar.php?id=11117>.
- Häehnlein, S., P. Bayer, and P. Blum. 2010. "International Legal Status of the Use of Shallow Geothermal Energy." *Renewable and Sustainable Energy Reviews* 14 (9): 2611 to 25.
- Heat Roadmap Europe. n.d. <https://heatroadmap.eu/>.

- HortiNews. 2018. "Oserian Flowers Rewarded for Innovation, Inclusivity in the Workplace." October 2, 2018. <https://www.hortinews.co.ke/2018/10/02/oserial-flowers-rewarded-for-innovation-inclusivity-in-the-workplace/>.
- Iceland Monitor. 2020. "Icelandic Biotech Firm Receives Large European Grant." August 1, 2020. [https://icelandmonitor.mbl.is/news/news/2020/08/01/icelandic\\_biotech\\_firm\\_receives\\_large\\_european\\_gran/](https://icelandmonitor.mbl.is/news/news/2020/08/01/icelandic_biotech_firm_receives_large_european_gran/).
- IEA (International Energy Agency). 2019. *Renewables 2019: Analysis and Forecast to 2024*. Paris: IEA. <https://www.iea.org/reports/renewables-2019/heat>.
- IEA. 2020a. "World Energy Statistics and Balances 2020 (database)." Paris: IEA.
- IEA. 2020b. *World Energy Outlook 2020*. Paris: IEA.
- IEA. 2020c. *Renewables 2020*. Paris: IEA. <https://www.iea.org/reports/renewables-2020>.
- IEA. 2021. *Heating*. Paris: IEA. <https://www.iea.org/reports/heating>.
- IEA. n.d. "Data and Statistics." <https://www.iea.org/data-and-statistics?country=WORLD&fuel=Electricity%20and%20heat&indicator=Heat%20generation%20from%20renewables%20and%20waste%20by%20source>.
- IGA (International Geothermal Association). 2013. *Geothermal Exploration Best Practices: A Guide To Resource Data Collection, Analysis, and Presentation For Geothermal Projects* Bochum, Germany: IGA.
- IGA (International Geothermal Association). 2014. *Best Practices Guide for Geothermal Exploration*. Bochum, Germany: IGA.
- IRENA (International Renewable Energy Agency). 2015. *Renewable Energy in the Water, Energy & Food Nexus*. Abu Dhabi: IRENA. <https://www.irena.org/publications/2015/Jan/Renewable-Energy-in-the-Water-Energy--Food-Nexus>.
- IRENA. 2019. *Accelerating Geothermal Heat Adoption in the Agri-Food Sector: Key Lessons and Recommendations*. Abu Dhabi: IRENA. [https://www.irena.org/-/media/Files/IRENA/Agency/Publication/2019/Jan/IRENA\\_Geothermal\\_agri-food\\_2019.pdf](https://www.irena.org/-/media/Files/IRENA/Agency/Publication/2019/Jan/IRENA_Geothermal_agri-food_2019.pdf).
- IRENA. 2020a. *Renewable Power Generation Costs in 2019*. Abu Dhabi: IRENA. [https://www.irena.org/-/media/Files/IRENA/Agency/Publication/2020/Jun/IRENA\\_Power\\_Generation\\_Costs\\_2019.pdf](https://www.irena.org/-/media/Files/IRENA/Agency/Publication/2020/Jun/IRENA_Power_Generation_Costs_2019.pdf)
- IRENA. 2020b. *Geothermal Development in Eastern Africa: Recommendations for Power and Direct Use*. Abu Dhabi: IRENA.
- Kelly, Nicola. 2017. "No Bed of Roses: The Kenyan Flower Pickers Fighting Sexual Harassment." BBC News, March 5, 2017. <https://www.bbc.com/news/business-39103419>.
- KenGen. n.d. "Who We Are." <https://www.kengen.co.ke/index.php/our-company/who-we-are.html>.
- KeyNatura. n.d. <https://www.keynatura.com/?lang=en>.
- Kinyanjui, S. 2013. *Direct Use of Geothermal Energy in Menengai, Kenya: Proposed Geothermal Spa and Crop Drying*. Reykjavik, Iceland: United Nations University, Geothermal Training Programme. <https://orkustofnun.is/gogn/unu-gtp-report/UNU-GTP-2013-09.pdf>.
- Kjalarsdóttir, Lilja. 2018. "SagaNatura (former KeyNatura)." Presentation at the GEORG Geothermal Workshop, Reykjavík, Iceland, November 14 to 15, 2018. [https://geothermalworkshop.com/wp-content/uploads/2018/12/ggw2018\\_plenarysession\\_keynatura.pdf](https://geothermalworkshop.com/wp-content/uploads/2018/12/ggw2018_plenarysession_keynatura.pdf).

- Limberger, J., T. Boxem, M. Pluymaekers, D. Bruhn, A. Manzella, P. Calcagno, F. Beekman, S. Cloetingh, and J-D. van Wees. 2018. "Geothermal Energy in Deep Aquifers: A Global Assessment of the Resource Base for Direct Heat Utilization." *Renewable & Sustainable Energy Reviews* 82 (Part 1, February): 961 to 75. <https://www.sciencedirect.com/science/article/pii/S1364032117313345>.
- Lindal, B. 1973. "Industrial and Other Applications of Geothermal Energy." In *Geothermal Energy*, edited by H. C. H. Armstead. Paris: UNESCO. <https://islofrocks30.com/the-lindal-diagram-an-overview/>.
- Lund, J. W. 2006. "Chena Hot Springs." [https://www.researchgate.net/profile/John-Lund-6/publication/266447627\\_Chena\\_hot\\_springs/links/571f909708aead26e71b6918/Chena-hot-springs.pdf](https://www.researchgate.net/profile/John-Lund-6/publication/266447627_Chena_hot_springs/links/571f909708aead26e71b6918/Chena-hot-springs.pdf).
- Lund, J. W. 2012. "Direct Heat Utilization of Geothermal Energy." In *Comprehensive Renewable Energy*, edited by Ali Sayigh, 169 to 86. Oxford: Elsevier. [https://www.elsevier.com/books/comprehensive-renewable-energy/letcher/978-0-08-087872-0?countrycode=US&format=print&utm\\_source=google\\_ads&utm\\_medium=paid\\_search&utm\\_campaign=usashopping&gclid=Cj0KCQiA15yNBhDTARIsAGnwe0VgLUYIW\\_HyDx-a-vpgPPDNtEtvGT5UdNhKKFcJ2ZkkEJ-S70iVbEEAmwBEALw\\_wcB&gclsrc=aw.ds](https://www.elsevier.com/books/comprehensive-renewable-energy/letcher/978-0-08-087872-0?countrycode=US&format=print&utm_source=google_ads&utm_medium=paid_search&utm_campaign=usashopping&gclid=Cj0KCQiA15yNBhDTARIsAGnwe0VgLUYIW_HyDx-a-vpgPPDNtEtvGT5UdNhKKFcJ2ZkkEJ-S70iVbEEAmwBEALw_wcB&gclsrc=aw.ds).
- Lund, J. W., and A. N. Toth. 2020. "Direct Utilization of Geothermal Energy 2020 Worldwide Review." Proceedings, World Geothermal Congress 2020, Reykjavik, Iceland, April 26 to May 2, 2020.
- Lund, J. W., and A. N. Toth. 2015. "Direct Utilization of Geothermal Energy 2020 Worldwide Review." *Geothermics* 90 (February): 1019 to 15. <https://www.sciencedirect.com/science/article/pii/S0375650520302078?via%3Dihub>.
- Mangi, P. M. 2017. "Geothermal Exploration in Kenya—Status Report and Updates." Presentation at the "SDG Short Course II on Exploration and Development of Geothermal Resources," organized by UNU-GTP, GDC, and KenGen, Lake Bogoria and Lake Naivasha, Kenya, November 9 to 29, 2017. <https://orkustofnun.is/gogn/unu-gtp-sc/UNU-GTP-SC-25-0701.pdf>.
- Mburu, M. 2014. "Geothermal Energy Utilization at Oserian Flower Farm-Naivasha." Presentation at the "Short Course VI on Utilization of Low- and Medium-Enthalpy Geothermal Resources and Financial Aspects of Utilization," organized by UNU-GTP and LaGeo, Santa Tecla, El Salvador, March 23 to 29, 2014. <https://orkustofnun.is/gogn/unu-gtp-sc/UNU-GTP-SC-18-24.pdf>.
- Mercury Bay. n.d. "World Famous Hot Water Beach." <http://www.mercurybay.co.nz/activities/hotwaterbeach.php>.
- Ministry of Economic Affairs and Climate Policy, the Netherlands. 2018. <https://www.government.nl/ministries/ministry-of-economic-affairs-and-climate-policy>
- Ministry of Economic Affairs and Climate Policy, the Netherlands. 2020. *SDE++ 2020, Stimulation of Sustainable Energy Production and Climate Transition*. The Netherlands: Netherlands Enterprise Agency. <https://english.rvo.nl/sites/default/files/2020/11/Brochure%20SDE%20plus%20plus%202020.pdf>.
- Ministry of the Interior and Kingdom Relations, the Netherlands. n.d. "Data Types." <https://basisregistratieondergrond.nl/english/data-types/>.
- Miraka. n.d. <https://www.miraka.co.nz>.
- Nordic Wasabi. n.d. "About." <https://www.nordicwasabi.com/#about>.
- NREL. 2021. "Geothermal Power Production and District heating Market report." <https://www.nrel.gov/docs/fy21osti/78291.pdf>.
- Orkustofnun. n.d. "Talnaefni." <https://orkustofnun.is/orkustofnun/gagnasofn/talnaefni/>.

- Oserian. n.d. "Our Story." <https://www.oserian.com/responsibility.html>.
- Pálsson, Bjarni. 2017. "Feasibility Studies for Geothermal Projects." Presentation at the "SDG Short Course II on Feasibility Studies for Geothermal Projects," organized by UNU-GTP and LaGeo, Santa Tecla, El Salvador, September 17 to 23, 2017. <https://orkustofnun.is/gogn/unu-gtp-sc/UNU-GTP-SC-24-02.pdf>.
- Ramsak, Paul. 2020. "Geothermal Energy in the Netherlands." Presentation at the IRENA Webinar "Energy Solutions for Cities in the Future," May 14, 2020. <https://irena.org/-/media/Files/IRENA/Agency/Events/2020/May/Developing-enabling-frameworks-for-geothermal-heating---The-case-of-The-Netherlands.pdf?la=en&hash=1CB15D2845FDCC1DFDCD1EC813963940C836E9F5>.
- REN21 (Renewable Energy Policy Network for the 21st Century). 2020. *Renewables 2020 Global Status Report*. Paris: REN21 Secretariat. [https://www.ren21.net/wp-content/uploads/2019/05/gsr\\_2020\\_full\\_report\\_en.pdf](https://www.ren21.net/wp-content/uploads/2019/05/gsr_2020_full_report_en.pdf).
- Richter, Alexander. 2019. "Oserian Development Named Best Renewable Energy Company in Kenya." Think Geoenergy, April 18, 2020. <https://www.thinkgeoenergy.com/oserian-development-named-best-renewable-energy-company-in-kenya/>.
- Richter, Alexander. 2020a. "Innovation in Geothermal Energy Utilization—The Icelandic Story." Think Geoenergy, March 24. <https://www.thinkgeoenergy.com/innovation-in-geothermal-energy-utilization-the-icelandic-story/>.
- Richter, Alexander. 2020b. "First Industrial-Grade Geothermal Food Dehydrator of Latin America Installed in Nayarit, Mexico." Think Geoenergy, September 25. <https://www.thinkgeoenergy.com/first-industrial-grade-geothermal-food-dehydrator-of-latin-america-installed-in-nayarit-mexico/>.
- Roquette. n.d. <https://www.roquette.com/>.
- Rybach, Ladislaus. 2015. "Figure 1: Classification of Geothermal Resources by Potential." *Geothermal Energy Science* 3 (1): 13 to 17. [https://www.researchgate.net/figure/Potential-definitions-for-renewable-energy-they-also-apply-to-geothermal-energy-From\\_fig1\\_277572997](https://www.researchgate.net/figure/Potential-definitions-for-renewable-energy-they-also-apply-to-geothermal-energy-From_fig1_277572997).
- Schomer, Inka, and Alicia Hammond. 2020. *Stepping Up Women's STEM Careers in Infrastructure: An Overview of Promising Approaches*. Washington, DC: World Bank.
- Secret Lagoon. n.d. <https://secretlagoon.is/>.
- Stefansson, V., and G. Axelsson. 2003. "Sustainable Utilization of Geothermal Energy Resources." IGC2003 Short Course, UNU-GTP, Reykjavík, Iceland. <https://orkustofnun.is/gogn/unu-gtp-report/UNU-GTP-2003-01-02.pdf>.
- Takhini Hot Pools. n.d. "Takhini Hot Pools." <http://takhinihotpools.com/>.
- TMGO (Tulu Moye Geothermal). n.d. "The Team." <https://www.tmgeothermal.com/team/>.
- Tuwharetoa Geothermal. n.d. "Renewable Iwi Energy Partners." <https://www.tuwharetoageothermal.co.nz/partners>.
- UN (United Nations). 2018. *Accelerating SDG 7 Achievement Policy Briefs in Support of the First SDG 7 Review at the UN High-Level Political Forum 2018*. New York: United Nations. [https://sustainabledevelopment.un.org/content/documents/18041SDG7\\_Policy\\_Brief.pdf](https://sustainabledevelopment.un.org/content/documents/18041SDG7_Policy_Brief.pdf).
- UNECE (United Nations Economic Commission for Europe). n.d. "UNFC and Geothermal Energy." <https://unece.org/sustainable-energyunfc-and-sustainable-resource-management/unfc-and-geothermal-energy>.
- UNIDO (United Nations Industrial Development Organization). 2017. *Implementation Handbook for Eco-Industrial Parks*. Vienna, Austria: UNIDO.

- US Office of Energy Efficiency & Renewable Energy. n.d.(a). "Electricity Generation." <https://www.energy.gov/eere/geothermal/electricity-generation>.
- US Office of Energy Efficiency & Renewable Energy. n.d.(b). "Geothermal Heat Pumps." <https://www.energy.gov/eere/geothermal/geothermal-heat-pumps>.
- Van Nguyen, M., S. Arason, M. Gissurason, and P. G. Pálsson. 2015. *Uses of Geothermal Energy in Food and Agriculture: Opportunities for Developing Countries*. Rome: Food and Agriculture Organization. [https://books.google.com/books/about/Uses\\_of\\_Geothermal\\_Energy\\_in\\_Food\\_and\\_Ag.html?id=Da5YrgEACAAJ](https://books.google.com/books/about/Uses_of_Geothermal_Energy_in_Food_and_Ag.html?id=Da5YrgEACAAJ).
- Verkís, BBA/Fjeldco, Intellecton, Stratégie, and gestion Publiques. *Exploitation de L'énergie Géothermique sur le Territoire de l'Eurométropole de Strasbourg*. Report prepared in 2019 for the Eurométropole de Strasbourg, Strasbourg, France.
- Warren, Ian. 2021. *Techno-Economic Analysis of Lithium Extraction from Geothermal Brines*. Golden, CO: National Renewable Energy Laboratory. NREL/TP-5700-79178. <https://www.nrel.gov/docs/fy21osti/799178.pdf>.
- WED (Women's Entrepreneurship Day). n.d. "Social Impact." <https://www.womenseday.org/impact/social-impact/>.
- World Bank. 2020. *Women, Business and the Law 2020*. Washington, DC: World Bank. <https://openknowledge.worldbank.org/bitstream/handle/10986/32639/9781464815324.pdf>.
- World Bank and TKYB (Development and Investment Bank of Turkey). 2021. "Risk Sharing Mechanism." Consultation Workshop RSM Round 2. <https://rpmjeoturkiye.com/wp-content/uploads/2021/01/GEO-RSM-TKYB-Consultation-Workshop-20210120.pdf>.



# ANNEX A. EXAMPLE OF LEVELIZED COST OF HEAT ESTIMATES OF DIRECT-USE INSTALLATIONS

Investment costs vary greatly between direct-use applications and also depending on how and where the energy is harnessed, processed, and distributed. One cannot easily define standard costs. It is, however, instructive to provide examples of how to calculate the levelized cost of heat (LCOH) in the case of geothermal heat as well as geothermal district heating.

Note that the cost figures provided here are indicative and will vary based on component characteristics. The examples are based on the assumptions provided and are not to be used directly unless adapted to the local conditions.

## Drilling and Resource Gathering System

### Drilling into low- and medium-temperature resources

Table A1.1 summarizes the main factors influencing the cost of drilling, and associated values typically seen for drilling down to 3,000 meters. The cost presented here is thus on the high side as it assumes wells are 1,500 to 3,000 meters deep.

Based on the assumptions given above, the cost of drilling is in the range of \$0.03 to 0.08 million/kilogram/second, which amounts to \$200 to 500/kW if the temperature drop of the fluid is around 40°C for wells 1,500 to 3,000 meters deep.

**TABLE A1.1: DESIGN CONDITIONS FOR COST ESTIMATE**

FACTOR	TYPICAL RANGE
Access to geothermal sites	Site dependent
Well depth	Up to 3,000 meters
Well flow rate	20 to 150 kilograms per second
Resource temperature	50 to 150 degrees Celsius
Distance between wells	500 to 1,500 meters
Resource gathering system	1 to 2 kilometers piping/well

Source: Original compilation for this publication.

### Drilling cost for direct use in combined production mode, from electrical production

In design where geothermal heat is harnessed alongside electricity production, the main factors influencing the cost are:

- Connection to the existing process and specific cost related to the direct use
- Common cost related to harnessing the resource

Usually, the connection to the process is not cost intensive. The main challenges lie in the split of the shared costs between the electricity and heat production. Typical shared costs are related to drilling, the resource gathering system, and the separator system. One approach is to use the “exergy” (the maximum useful work possible during a process that brings the system into equilibrium with a heat reservoir) at a reference temperature to find out when 1 MW<sub>th</sub> of heat derived at certain temperature equals 1 MW<sub>e</sub> of electricity. Figure A1.1 shows the equivalent electrical power for one unit of thermal power as a function of temperature, with an assumed reference return temperature of 40°C.

With reference to Figure 4.7, which features the ratio of heat potential to electricity produced as a function of enthalpy, it is assumed for the case presented here that the maximum heat produced is 2 MW<sub>th</sub> per 1 MW<sub>e</sub> of electricity from a source with 1,500 kJ/kg enthalpy, and the heat is produced from a separator at 160°C. In this case, 2 MW<sub>th</sub> of heat is equivalent to 0.34 MW<sub>e</sub> of electricity according to Figure A1.1. The sum of

**FIGURE A1.1: EQUIVALENT ELECTRICAL POWER FOR ONE UNIT OF THERMAL POWER AS A FUNCTION OF TEMPERATURE**

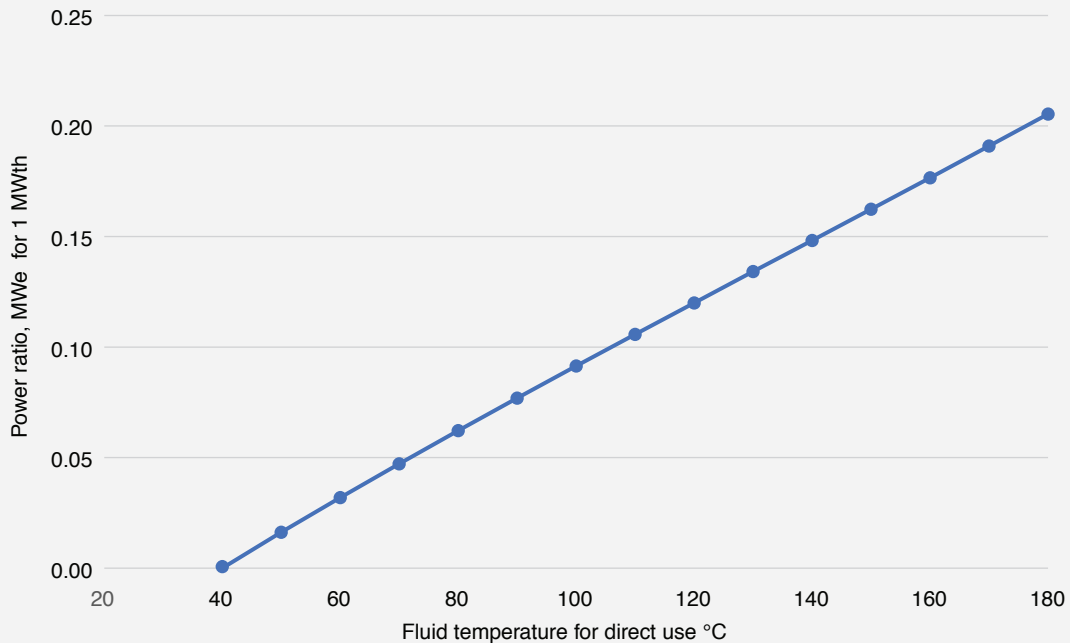

Source: Original calculations for this publication.

Note: MW<sub>e</sub> = megawatt electric; MW<sub>th</sub> = megawatt thermal.

electricity equivalent generated from this case is thus 1.34 MW<sub>e</sub>. The cost split ratio for the shared cost should be  $0.34/1.34 = 0.25$ .

The cost of wells and the resource gathering system for electricity production is in the range of \$2 million/MW<sub>e</sub> and thus the direct-use share is close to \$500/kW thermal. This demonstrates that cost drilling for individual GDU projects is not more expensive than the share of the GDU projects in the gathering system. However, the resource risk is significantly lower for the GDU project when in cogeneration.

In some cases, it may be necessary to use a different reference temperature for the exergy evaluation and a different number of utilization hours for electricity production and heat production to split the shared cost more accurately. Using the installed power only is relatively easy if the utilization hours are similar. This may be relevant for industrial applications but not for district heating applications.

### Transportation of Hot Water

To transport geothermal fluid from a geothermal field to a heat central, within or near a populated area, a double pre-insulated piping system is the common choice. Figure A1.2 shows selection curves for various nominal flows.

**FIGURE A1.2: DOUBLE-PIPE MAIN: INSTALLATION COST, FLOW, AND MAXIMUM VIABLE TRANSPORTATION DISTANCE**

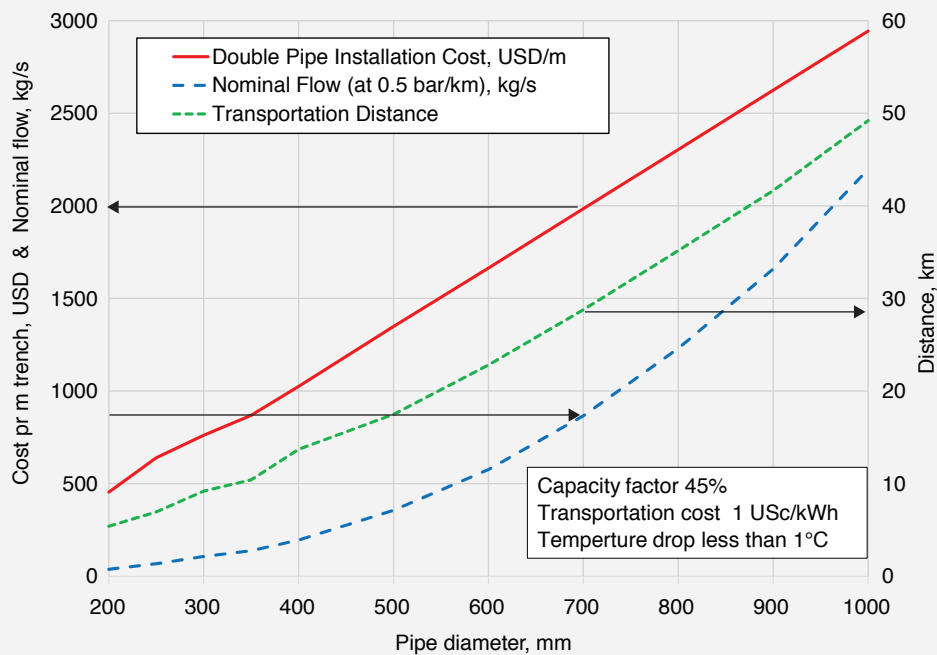

Source: Original calculations for this publication.

Note: kg/s = kilograms per second; km = kilometer; mm = millimeter; USD/m = US dollars per meter; USc/kWh = US cents per kilowatt-hour.

The basic selection curves for geothermal pipe mains, listed in Figure A1.2, provide an indication of the maximum economical transportation distance based on estimated heat loss from the piping and the share of transportation cost in the user's energy bill.

To demonstrate, starting on the y-axis on the left for a nominal flow of 800 kg/s, the most suitable pipeline size to transport to and from the end use would be DN 700 (two pipelines), as indicated on the x-axis from the blue curve. The associated cost can be read on the red curve and is about \$2,000/meter of trench. The maximum feasible transportation distance is read on the y-axis on the right and is 28 km for this case.

In this case 800 kg/s refers to 135 MW<sub>th</sub> if the temperature drop is assumed to be 40°C. The cost of a 28 km pipe is \$56 million, which is equivalent to \$400/kW. This implies a high-end price since systems with a shorter transportation distance will have a lower cost. By assuming a constant flow of 45 percent of the year or 3,942 hours a year (capacity factor), the calculated transportation cost is \$0.01/kilowatt per hour. The capacity factor has to be calculated for each application based on weather data and heat demand.

### Heat Central

Various heat central systems can be used to provide end users with hot water. Heat centrals with a peak load boiler might be an economic solution, and such a configuration should be assessed among other options based on the capacity of the geothermal resource and on the peak space heating demand.

The cost of heat centrals is highly dependent on the setup and equipment required for each project as well as on various local conditions. However, a bulk price for a geothermal heat central and an optimum combination of heat pumps and peak load boiler is about \$120/kW of installed capacity.

### Distribution System

The system that distributes the heat to the end consumers for district heating systems consists of supply and return pipes connecting the heat central to the end users. The typical cost of a distribution system involves both connection and installation. The connection cost in an urban area is about \$50,000/hectare of land, whereas the installation cost is almost constant per hectare and does not vary with building and land density. The cost is more sensitive to the surface finish, especially in high-density areas.

It is cheapest to install such a system while housing and streets are being developed. It is more expensive to install a distribution system in an area with fully developed urban infrastructure because of the cost associated with the surface repairing and finish.

To estimate the cost of the distribution system, population density has to be considered, as well as the energy needed per square meter. A heat demand of 50 W/m<sup>2</sup> and the cost of land at \$5/m<sup>2</sup> are assumed based on experience mostly in China and Europe.

In high-density residential areas, heated floor space per square meter (also known as utilization) of land can be as high as 1.5 residents/m<sup>2</sup>. This means that for 75 W/m<sup>2</sup> of land (assuming the 50W/m<sup>2</sup>), the cost is \$5/75 W or \$67/kW.

In urban or rural residential areas consisting of single-family housing, the utilization can be as low as 0.25 residents/m<sup>2</sup> and thus 12.5 W/m<sup>2</sup> of land corresponds to \$400/kW (see Figure A1.3).

**FIGURE A1.3: POPULATION DENSITY (UTILIZATION) AND ESTIMATED DISTRIBUTION COST**

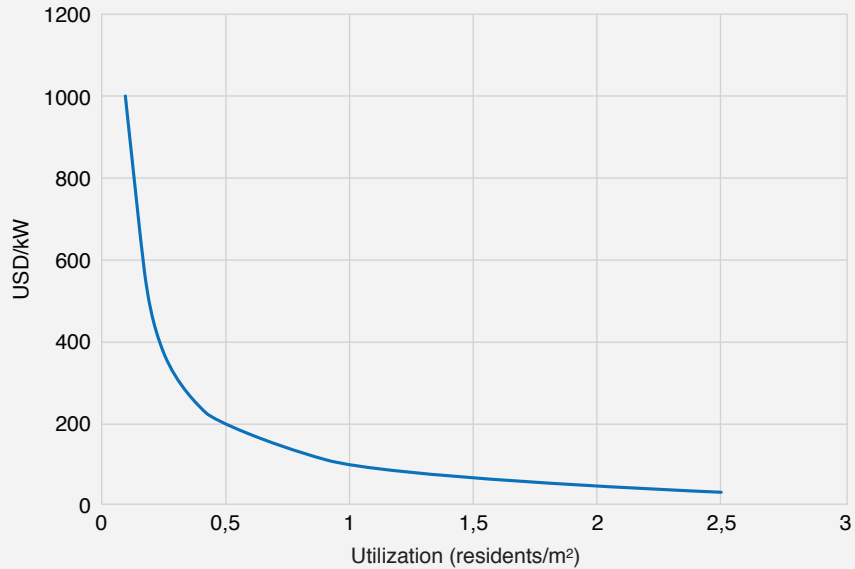

Source: Original calculations for this publication.

Note: USD/kW = US dollars per kilowatt.

### Examples of Levelized Cost of Heat (LCOH)

To demonstrate the indicative cost estimate that can be derived from previous sections, two examples are provided: sales of geothermal heat, and a district heating system (including distribution but not individual house heating installations).

The preliminary cost estimate and basic design premises are presented in Table A1.2. All numbers are rounded, as they are only indicative.

Operation and maintenance (operating expenditure, OPEX) is estimated at 5 percent and includes all consumables as well as maintenance. The OPEX varies for different locations and is dependent on factors such as electricity price, gas price (if peak boilers are used), labor costs, and the type and quality of the resource. The estimated 5 percent is believed to be close to the average value based on consultants experience mostly in China and Europe.

To estimate the LCOH, the yearly production is calculated assuming a 45 percent capacity factor. When designing a system, it is important to maximize the capacity factor of the geothermal loop. The optimization can involve installing a peak load capacity (boilers) and/or design the system to include cascaded use and multiple production. The main assumptions for the calculation and the results are presented in Table A1.3 for both examples.

The capacity factor has significant influence on the viability of the system. In Table A1.4 the LCOH is given for three different capacity factors for both options.

**TABLE A1.2: ESTIMATED COSTS OF GEOTHERMAL HEAT SALES AND UTILIZATION FOR DISTRICT HEATING**

	GEOTHERMAL HEAT		DISTRICT HEATING SYSTEM	
	QUANTITY	COST	QUANTITY	COST
Drilling and resource gathering system	One reinjection and one production well	\$200 to 500/kW	One reinjection and one production well	\$200 to 500/kW
Transportation	2 km	\$80/kW	28 km	\$400/kW
	50 MW		135 MW	
	300 kg/s		800 kg/s	
Heat central	1 unit	\$120/kW	1 unit	\$120/kW
Distribution	No distribution	0	1.25 to 0.25 density	\$80 to 400/kW
			50 W/m <sup>2</sup>	
			US\$5/m <sup>2</sup>	
<b>Total</b>		<b>\$400 to 700/kW</b>		<b>\$800 to 1,420/kW</b>
<b>Size</b>	<b>50 MW</b>		<b>135 MW</b>	
<b>Preliminary CAPEX</b>		<b>\$20 to 35 million</b>		<b>\$108 to 192 million</b>
<b>Preliminary OPEX</b>	<b>5%</b>	<b>\$1 to 2 million</b>	<b>5%</b>	<b>\$5.5 to 10 million</b>

Source: Original compilation for this publication.

Note: CAPEX = capital expenditure; kg/s = kilograms per second; kW = kilowatt; MW = megawatt; OPEX = operating expenditure; W/m<sup>2</sup> = watts per square meter.

As can be seen, the prices for heat sales can be as low as \$14/MWh and as high as \$51/MWh, depending on the cost and capacity factor. For district heating systems, the price range is \$28 to 100/MWh. In the US the LCOH for district heating assumes a 30-year lifetime, 5 percent discount rate, and overnight construction ranges of \$15 to 105/MWh depending on location, capacity factor, and resource, with an average of \$54/MWh (NREL 2021). As an example, if the heating required is 50 W/m<sup>2</sup>, the cost may be estimated at \$400 to 1,200/kW, depending on the size of the space, which is in line with the estimated cost. Tables A1.3 and A1.4 can therefore be used to offer a rough estimate for the assumptions provided. For example, a small 10 MW<sub>th</sub> and 1 MW<sub>e</sub> plant in Austria delivers heat to district heating consumers for \$27 to 44/MWh (Lund 2012).

**TABLE A1.3: FINANCIAL ASSUMPTIONS AND LCOH OF TWO OPTIONS**

	<b>GEOHERMAL HEAT SALES</b>	<b>DISTRICT HEATING SYSTEM</b>
Production	197,100 MWh	532,170 MWh
Capacity factor	45 percent	45 percent
Discount rate	8 percent <sup>6</sup>	8 percent
Operation	20 years	20 years
<b>LCOH</b>	<b>\$18.5 to 34/MWh</b>	<b>\$37 to 66.5/MWh</b>

*Source:* Original compilation for this publication.

*Note:* LCOH = levelized cost of heat; MWh = megawatt-hour.

**TABLE A1.4: LCOH OF TWO OPTIONS, WITH VARIOUS CAPACITY FACTORS**

	<b>GEOHERMAL HEAT SALES (\$/MWH)</b>	<b>DISTRICT HEATING SYSTEM (\$/MWH)</b>
<b>LCOH (30% capacity factor)</b>	27.5 to 51	55.5 to 99.5
<b>LCOH (45% capacity factor)</b>	18.5 to 34	37 to 66.5
<b>LCOH (60% capacity factor)</b>	14 to 25.5	28 to 50

*Source:* Original compilation for this publication.

*Note:* LCOH = levelized cost of heat; MWh = megawatt-hour.

<sup>6</sup> Discount rates vary between countries, investors, and so on. A government discounts using a “social discount rate” which measures the rate of time preference for the country while a private investors would typically set the discount rate at the opportunity cost of capital.









## ESMAP MISSION

The **Energy Sector Management Assistance Program** (ESMAP) is a partnership between the World Bank and 24 partners to help low- and middle-income countries reduce poverty and boost growth through sustainable energy solutions. ESMAP's analytical and advisory services are fully integrated within the World Bank's country financing and policy dialogue in the energy sector. Through the World Bank Group (WBG), ESMAP works to accelerate the energy transition required to achieve Sustainable Development Goal 7 (SDG7) to ensure access to affordable, reliable, sustainable, and modern energy for all. It helps to shape WBG strategies and programs to achieve the WBG Climate Change Action Plan targets. Learn more at: <https://esmap.org>



**Energy Sector Management Assistance Program**  
The World Bank

1818 H Street, N.W.  
Washington, DC 20433 USA  
[esmap.org](http://esmap.org) | [esmap@worldbank.org](mailto:esmap@worldbank.org)